



Chipsmall Limited consists of a professional team with an average of over 10 year of expertise in the distribution of electronic components. Based in Hongkong, we have already established firm and mutual-benefit business relationships with customers from,Europe,America and south Asia,supplying obsolete and hard-to-find components to meet their specific needs.

With the principle of "Quality Parts,Customers Priority,Honest Operation,and Considerate Service",our business mainly focus on the distribution of electronic components. Line cards we deal with include Microchip,ALPS,ROHM,Xilinx,Pulse,ON,Everlight and Freescale. Main products comprise IC,Modules,Potentiometer,IC Socket,Relay,Connector.Our parts cover such applications as commercial,industrial, and automotives areas.

We are looking forward to setting up business relationship with you and hope to provide you with the best service and solution. Let us make a better world for our industry!



Contact us

Tel: +86-755-8981 8866 Fax: +86-755-8427 6832

Email & Skype: info@chipsmall.com Web: www.chipsmall.com

Address: A1208, Overseas Decoration Building, #122 Zhenhua RD., Futian, Shenzhen, China



MAXIM

MAX1403 EV System

General Description

The MAX1403 evaluation system (EV system) is a complete, multichannel data-acquisition system consisting of a MAX1403 evaluation kit (EV kit) and a Maxim 68HC11 microcontroller (μ C) module. The MAX1403 is a low-power, multichannel, serial-output analog-to-digital converter (ADC). Windows 95/98™-compatible software provides a handy user interface to exercise the MAX1403's features. Source code in C++ and 68HC11 assembly language is provided for the low-level portion of the software.

Order the EV system for comprehensive evaluation of the MAX1403 using a personal computer. Order only the EV kit if the 68HC11 μ C module has already been purchased with a previous Maxim EV system or for custom use in other μ C-based systems.

The MAX1403 EV kit and EV system can also be used to evaluate the MAX1401. Simply order a free sample of the MAX1401CAI along with the MAX1403EVKIT.

MAX1403 Stand-Alone EV Kit

The MAX1403 EV kit provides a proven PC board layout to facilitate evaluation of the MAX1403 with user-provided software and hardware. It must be interfaced to appropriate timing signals for proper operation. Refer to the MAX1403 data sheet for timing requirements. See Table 2 for jumper functions.

MAX1403 EV System

The MAX1403 EV system operates from a user-supplied +5V to +12V DC power supply.

MAX1403 EV System Component List

PART	QTY	DESCRIPTION
MAX1403EVKIT	1	MAX1403 Evaluation Kit
68L11DMODULE	1	68HC11 μ C Module

Windows 95/98 is a trademark of Microsoft Corp.

Features

- ◆ Easy to Configure
- ◆ Collects Up to 8192 Samples at Full Speed
- ◆ Complete Evaluation System
- ◆ Proven PC Board Layout
- ◆ Fully Assembled and Tested

Ordering Information

PART	TEMP. RANGE	INTERFACE TYPE
MAX1403EVKIT	0°C to +70°C	User-Supplied
MAX1403EVL11	0°C to +70°C	Windows Software

Note: The MAX1403 software can be used only with the complete evaluation system (MAX1403EVL11), which includes the 68L11DMODULE together with the MAX1403EVKIT.

MAX1403 EV Kit Component List

DESIGNATION	QTY	DESCRIPTION
C3–C8	6	100pF ceramic capacitors (1206)
C9, C10, C11	3	0.1 μ F ceramic capacitors (1206)
C12, C13	0	Not installed
C15	1	2.2 μ F aluminum electrolytic radial-leaded capacitor
J1	1	2 x 20 right-angle socket
J2	1	Female SMA connector
JU1–JU8	0	Not installed
R1–R6	6	100 Ω , 5% resistors (1206)
R7, R8	2	10 Ω , 5% resistors (1206)
R9	0	Not installed
R10	0	Not installed
U1	1	Maxim MAX1403CAI
U2	1	Maxim MAX6520EUR (SOT23 voltage reference, 1.2V, 20ppm/°C max)
Y1	1	2.4576MHz ceramic resonator Murata CST2.45MGW040
None	1	3" x 4" PC board MAX1403 evaluation kit
None	1	3 1/2" software disk MAX1403 evaluation kit
None	1	Maxim 68HC11 module monitor, ROM Version 1.1 (Version 1.0 ROM will not work with this EV kit.)

Evaluates: MAX1401/MAX1403

MAX1403 EV System

MAX1403 EV Kit Files

Windows Application Program Files

FILE	DESCRIPTION
MAX1403.EXE	Application program that runs under Windows 95/98
MAX1403.HLP	Help file
KIT1403.L11	Software loaded into 68HC11 microcontroller
MAX1403.INI	Program settings file

Example Source Code Files

FILE	DESCRIPTION
MAX1403.CPP	Source code module for driving the MAX1403, provided for reference. Includes definitions of the register names and low-level access routines. Compiled with Borland C++ 4.52. Maxim holds the copyright but allows customers to adapt the program for their own use without charge.
MAX1403.H	Header file for MAX1403.CPP, provided for reference.

68HC16 Source Code Files

FILE	DESCRIPTION
KIT1403.ASM	Main source code for the KIT1403.L11 program, provided for reference. Maxim holds the copyright but allows customers to adapt the program for their own use without charge.
EVKIT.ASM	Source code defining the program interface with the Maxim 68HC11 Module ROM (Rev. 1.1).

Install/Uninstall Program Files

FILE	DESCRIPTION
INSTALL.EXE	Installs the EV kit files on your computer.
UNINST.INI	Database for uninstall program.
UNMAXIM.EXE	Removes the EV kit files from your computer. This file is automatically copied to C:\WINDOWS during installation.

Quick Start

Recommended Equipment

Obtain the following equipment before you begin:

- A DC power supply that generates +5VDC to +12VDC at 30mA to 50mA
 - An IBM PC-compatible computer running Windows 95/98
 - A spare serial communications port, preferably a 9-pin plug
 - A serial cable to connect the computer's serial port to the Maxim 68HC11 Module
- 1) Before you begin, make sure your 68HC11 module has the Rev. 1.1 ROM. The software will not function with the Rev. 1.0 ROM.
 - 2) Carefully connect the boards by aligning the 40-pin header of the MAX1403 EV kit with the 40-pin connector of the 68HC11 module. Gently press them together. The two boards should be flush against one another.
 - 3) Connect the DC power source to the μ C module at terminal block J2, located next to the ON/OFF switch, along the top edge of the μ C module. Observe the polarity marked on the board.
 - 4) Connect a cable from the computer's serial port to the μ C module. If using a 9-pin serial port, use a straight-through, 9-pin female-to-male cable. If the only available serial port uses a 25-pin connector, a standard 25-pin to 9-pin adapter will be required. The EV kit software checks the modem status lines (CTS, DSR, DCD) to confirm that the correct port has been selected.
 - 5) Install the software on your computer by running the INSTALL.EXE program from the floppy disk. The program files are copied and icons are created for them in the Windows 95/98 Start Menu. The EV kit software evaluates both the MAX1403 and the MAX1401.
 - 6) Start the MAX1403 program by opening its icon in the Start Menu.
 - 7) The program will prompt you to connect the μ C module and turn its power on. Slide SW1 to the "ON" position. Select the correct serial port, and click OK. The program will automatically download the file KIT1403.L11 to the module.

MAX1403 EV System

Evaluates: MAX1401/MAX1403

- 8) When the software successfully establishes communication with the EV kit board, you will see a configuration tool and some other windows. Verify that the CLKIN and Reference Voltage settings are correct. Close or minimize this dialog box.
- 9) Apply input signals to the inputs labeled AIN1–AIN5, at the bottom edge of the MAX1403 EV kit board. AIN6 is analog common. Observe the readout on the screen.

Upgrading the 68HC11 Module

The MAX1403 EV kit requires Rev. 1.1 of the Maxim 68HC11 Module ROM. Check the label on device U10 on the module; if it says “Rev. 1.0,” the device must be replaced.

The Rev. 1.1 ROM is a 28-pin DIP that comes with the EV kit. If it was omitted, contact the factory for a replacement.

To install the new ROM, use the following procedure. Use antistatic handling precautions. To reduce the risk of ESD damage, gather all required materials and perform the installation at one sitting.

- 1) Slide the ON/OFF switch to the OFF position.
- 2) Using a flat-blade screwdriver, gently pry U10, the REV 1.0 ROM, out of its socket.
- 3) Remove the REV 1.1 ROM from its antistatic packaging.
- 4) Align the REV 1.1 ROM in the U10 socket pins. Observe correct polarity (the notch at the top of the ROM). Verify that the pins are lined up with the socket, and gently press the ROM into place.

Proceed to the regular *Quick Start* instructions.

Detailed Description of Software

The MAX1403 digitizes up to seven inputs. The various program functions are grouped into windows that are accessible from the Show menu on the main menu bar.

Main Display

The main display shows the calculated input voltage and raw A/D output code for each active channel. Although there are nine input channels, only certain configurations are allowed.

Select any single channel or one of the scanning sequences from the Inputs menu. AIN 1-6 designates an analog input between the AIN1 pin and the AIN6 pin. CALOFF designates the signal between the CALOFF+ and CALOFF- pins. CALGAIN designates the signal between the CALGAIN+ and CALGAIN- pins.

The EV kit software assumes that CALOFF+ and CALOFF- are grounded so that CALOFF measures 0V. Similarly, the software assumes that CALGAIN+ is connected to REFIN+ and CALGAIN- is connected to REFIN- so that CALGAIN measures the reference voltage. These two points calibrate the code-to-voltage translation function performed in the software.

The MAX1403 automatically triggers its measurements, unless the FSYNC control bit is set. The EV kit software communicates with the MAX1403 at intervals determined by the Update Every combo box. To halt this automatic update, uncheck the Update Every checkbox or change the Update Every to a value between 100ms and 60,000ms.

Normally, the microcontroller collects new data as soon as it becomes available by using the $\overline{\text{INT}}$ pin to trigger an interrupt service routine. If the $\overline{\text{INT}}$ pin is not used as an interrupt, then the MAX1403 must not be operated in free-running mode. Check or uncheck the Use $\overline{\text{INT}}$ Interrupt checkbox to configure the evaluation kit software.

Configuration Tool

The Configuration Tool controls parameters that apply to the entire EV kit. Like the other windows, the Configuration Tool can be activated from the Show menu of the main menu bar. The CLK control should match the external ceramic resonator or crystal that sets the master clock frequency. The VREF Reference Voltage control tells the software what the reference voltage is. This is used to convert the raw A/D output codes into the corresponding input voltage to speed user evaluation. The Data-Rate control determines how often the MAX1403 performs a measurement. Some data rates provide 16-bit, noise-free resolution when used with the SINC³ filter (discussed below). The Filter Sync control can be used to inhibit the MAX1403 from performing its self-timed measurements. The Buffer Inputs checkbox enables the internal input buffers. The Burnout Test Currents checkbox enables two small (0.1 μ A) current sources to provide an input stimulus. When used with a transducer, these current sources can be used to verify that the transducer has not failed open or short circuit.

At the bottom of the window are input voltage-range selection buttons. These buttons configure all input channels for the same input voltage range. Although the MAX1403 can be operated with three different input ranges at the same time, the EV kit software supports only a single range for all channels.

MAX1403 EV System

The digital filter on the MAX1403 can be configured for SINC³ or SINC¹ operation, which affects the filter cutoff frequency. (SINC¹ means $\text{SIN}(X) \div X$, and SINC³ means $(\text{SIN}(X) \div X)^3$.) The SINC³ filter is required for 16-bit accuracy. The SINC¹ filter provides faster settling time with less accuracy. Alternatively, the raw modulator output can be driven out the DOUT pin; however, the EV kit software cannot read data from the MAX1403 in this mode.

Calibration Tool

The MAX1403 EV kit software can average the measurements from the calibration channels and use the measured values to correct the voltage displays. The calibration algorithm assumes that the CALOFF inputs are externally connected together and that the CALGAIN inputs are externally connected to the reference voltage (VREF). View the calibration tool by selecting it from the Show menu.

The software automatically disables calibration if either of the calibration channels reports a code of 0 or 262143. This is to prevent erroneous calibration when using a transfer function that does not include both 0V and VREF.

When Use CALOFF and CALGAIN for Calibration is checked, the software averages the raw A/D codes for the CALOFF and CALGAIN channels. The average is calculated as a weighted sum of the new data and the old average value. The Slower/Faster slide bar controls the weight of the new data vs. the weight of the old average.

The EV kit software assumes that all three transfer function registers are set to the same value.

This calibration affects only the displayed voltage, not the raw code numbers. The average CALOFF and CALGAIN code values are used as the endpoints of a linear interpolation, with CALOFF measuring 0V and CALGAIN measuring VREF.

The linear interpolation formula is as follows:

$$\text{Voltage} = \frac{\text{VREF}(\text{Code} - \text{CALOFFcode})}{(\text{CALGAINcode} - \text{CALOFFcode})\text{PGAgain}}$$

Note: When using the calibration tool with the MAX1403 in buffered mode, CALOFF+ and CALOFF- should be disconnected from GND and connected instead to REFIN+ so that they remain within the specified input range.

Sampling Tool

To sample data at full speed, select Sample from the main display menu, make your selections, and click on

the Begin Sampling button. Sampling rate is controlled by the Configuration tool. Sample size is restricted to a power of two. Sample Size controls the number of samples collected on each selected channel. After the samples have been collected, the data is automatically uploaded to the host and is graphed. Once displayed, the data may be saved to a file.

While the Sampling tool is open, the other windows are locked out. Close the Sampling tool by clicking the Close icon in the upper corner.

Register Display Tool

This tool displays all of the internal registers of the MAX1403. Modify any bit value by checking or unchecking its box. (The START bit and the zero bits in the Special Function register (SFR) cannot be modified). The Read All Registers button causes the software to read all of the MAX1403's registers. (Not functional when the MDOUT or FULLPD bit is set.) Refer to Table 1 for a guide to register bit functions.

Communications Register (COMMS)

Setting the FSYNC control bit inhibits the MAX1403 from performing its self-timed measurements. If FSYNC = 1 when it is time to perform a measurement, the MAX1403 simply skips that measurement. Thus, power-line frequency rejection is not affected by the FSYNC bit.

Setting the STDBY bit places the part in low-power standby mode. The serial interface and the CLK oscillator continue to operate. The part can be restored to normal operation by clearing the STDBY bit.

Special Function Register (SFR)

Setting the MDOUT bit makes the raw modulator output available on the DOUT pin; however, the EV kit software cannot read data from the MAX1403 in this mode.

Setting the FULLPD bit in the SFR register places the part in full power-down mode. The master oscillator does not run. To restore normal operation, click on the Reset menu item in the main display. This causes the 68HC11 software to pulse the MAX1403 $\overline{\text{RESET}}$ pin.

Transfer Function Registers (TF1, TF2, TF3)

The three transfer function registers (TF1, TF2, TF3) control how input voltage is mapped to code values. The transfer function registers control a programmable-gain amplifier (PGA) and an offset-correction DAC.

If $U/\overline{B} = 1$, the transfer function maps unipolar voltages between 0V and VREF. If $U/\overline{B} = 0$, then the transfer function maps bipolar voltages between -VREF and +VREF. Next, the PGA increases the code-per-volt pro-

MAX1403 EV System

cessing gain, reducing the full-scale voltage range by a factor of 1, 2, 4, 8, 16, 32, 64, or 128. Finally, the offset-correction DAC offsets the voltage range by up to $\pm 7/6$ of the full-scale voltage range.

Input pins AIN1 and AIN2 are controlled by TF1. Input pins AIN3 and AIN4 are controlled by TF2. Input pin AIN5 is controlled by TF3. Input pin AIN6 is the analog common.

When SCAN = 1, the CALOFF and CALGAIN channels are controlled by TF3. When SCAN = 0, the CALOFF and CALGAIN channels are controlled by one of the transfer function registers, as selected by the A1 and A0 bits.

For simplicity, the EV kit software assumes that all three transfer functions are configured alike.

Detailed Description of Hardware

U1, the MAX1403, is a multichannel, high-resolution A/D converter (refer to the MAX1403 data sheet). U2, the MAX6520, is a 1.2V reference (refer to the MAX6520 data sheet). Y1 contains a ceramic resonator and its load capacitors. R1–R6, together with C3–C8, form anti-aliasing input filters. R8 and C11 filter the digital power supply. The analog supply comes through filter R7/C10.

Input Filtering

The EV kit has an RC filter on each input with a time constant of approximately $0.01\mu\text{s} = 10\text{ns}$ ($R = 100\Omega$,

$C = 100\text{pF}$). When scanning between channels, the RC filter's settling time may increase the acquisition time required for full accuracy.

Evaluating the MAX1401

The MAX1401 can be evaluated by shorting across jumpers JU6 and JU7. The MAX1401 is exactly like the MAX1403, except that the function of pins 5, 6, 7, and 8 is changed. Instead of the OUT1/OUT2 outputs and DS0/DS1 inputs, these pins are used to provide access to the analog signal between the multiplexer and the A/D converter. Tables 2 and 3 list the jumper functions and default settings. Refer to the MAX1401 data sheet for detailed information.

Measuring Supply Current

Supply current can be estimated by measuring the voltage across a series resistor. On the EV kit board, the MAX1403 draws all of its analog and digital power through R8, which is 10Ω . In addition, all analog supply current flows through R7, which is also 10Ω .

Troubleshooting

Problem: unacceptable amounts of noise in the signal.

Collect a sample of 1024 measurements at a 60Hz data rate. Observe whether the problem is caused by 60Hz noise.

Any AC-powered equipment connected to the analog signal ground can inject noise. Try replacing AC-powered DVMs with battery-powered DVMs.

Evaluates: MAX1401/MAX1403

MAX1403 EV System

Evaluates: MAX1401/MAX1403

Table 1. Guide to Register Bit Functions

REGISTER	BIT NAME	DESCRIPTION	
COMMS	0/DRDY	Start bit is zero; DIN pin must be 1 when idle.	
	RS2–RS0	Register select for subsequent operation	
	R/W	Selects subsequent read or write operation	
	RESET	Causes software reset when set to 1	
	STDBY	Activates standby power-down mode when set to 1	
	FSYNC	Inhibits the A/D converter when set to 1	
	GS1	A1	Selects the active channel
A0		Selects the active channel	
MF1		Selects the data output rate	
MF0		Selects the data output rate	
CLK		Selects the CLKIN frequency	
FS1		Selects the data output rate	
FS0		Selects the data output rate	
FAST		Selects SINC ¹ filter instead of SINC ³	
GS2		SCAN	Enables the scanning sequences
		M1	Enables the CalGain channel
	M0	Enables the CalOff channel	
	BUFF	Enables the input buffers	
	DIFF	Selects differential input pairs	
	BOUT	Enables the transducer burn-out test currents	
	IOUT	Enables the OUT1 and OUT2 current sources (MAX1403 only)	
SFR	X2CLK	Selects the CLKIN frequency	
	MDOUT	Changes the DOUT and $\overline{\text{INT}}$ pins to provide raw modulator output	
	FULLPD	Activates full power-down mode. Use hardware reset to restore normal operation.	
		All other bits in SFR must be zero	
TF1, 2, 3	G2–G0	Selects the PGA Gain	
	U/B	Selects unipolar or bipolar coding	
	D3–D0	Selects the offset correction DAC code; D3 = sign, D2–D0 = magnitude	
DATA	D17–D0	Raw code value	
	DS1	Value of the DS1 input pin (MAX1403 only)	
	DS0	Value of the DS0 input pin (MAX1403 only)	
	CID2–CID0	Channel identification tag	

MAX1403 EV System

Evaluates: MAX1401/MAX1403

Table 2. Jumper Functions

JUMPER	STATE	FUNCTION
JU1	Closed*	Use CalGain inputs for gain calibration (CALGAIN+ = REFIN+)
	Open	Use CalGain inputs as general purpose signal inputs
JU2	Closed*	Use CalGain inputs for gain calibration (CALGAIN- = REFIN-)
	Open	Use CalGain inputs as general purpose signal inputs
JU3	Closed*	Use CalOff inputs for offset calibration (CALOFF+ = GND)
	Open	Use CalOff inputs as general purpose signal inputs
JU4	Closed*	Use CalOff inputs for offset calibration (CALOFF- = GND)
	Open	Use CalOff inputs as general purpose signal inputs
JU5	Closed*	Use on-board reference U2 (REFIN- = GND)
	Open	REFIN+ and REFIN- must be driven by an external reference
JU6	Closed	Connects pin 5 to pin 7 MAX1403: pin 5 = digital input DS1, pin 7 = current source MAX1401: normal operation
	Open	Disconnects pin 5 from pin 7 MAX1403: pin 5 = digital input DS1, pin 7 = current source MAX1401: insert filter between mux and A/D
JU7	Closed	Connects pin 6 to pin 8 MAX1403: pin 6 = digital input DS0, pin 8 = current source MAX1401: normal operation
	Open	Disconnects pin 6 from pin 8 MAX1403: pin 6 = digital input DS0, pin 8 = current source MAX1401: insert filter between mux and A/D
JU8	Closed*	Use on-board reference U2 (REFIN+ = 1.2V)
	Open	REFIN+ and REFIN- must be driven by an external reference

* Default trace on top layer of PC board

Table 3. Default Jumper Settings

JUMPER	STATE	FUNCTION
JU1	Closed*	Use CalGain inputs for gain calibration (CALGAIN+ = REFIN+)
JU2	Closed*	Use CalGain inputs for gain calibration (CALGAIN- = REFIN-)
JU3	Closed*	Use CalOff inputs for offset calibration (CALOFF+ = GND)
JU4	Closed*	Use CalOff inputs for offset calibration (CALOFF- = GND)
JU5	Closed*	Use on-board reference U2 (REFIN- = GND)
JU6	Open	Disconnects pin 5 from pin 7 MAX1403: pin 5 = digital input DS1, pin 7 = current source MAX1401: insert filter between mux and A/D
JU7	Open	Disconnects pin 6 from pin 8 MAX1403: pin 6 = digital input DS0, pin 8 = current source MAX1401: insert filter between mux and A/D
JU8	Closed*	Use on-board reference U2 (REFIN+ = 1.2V)

* Default trace on top layer of PC board

Evaluates: MAX1401/MAX1403

MAX1403 EV System

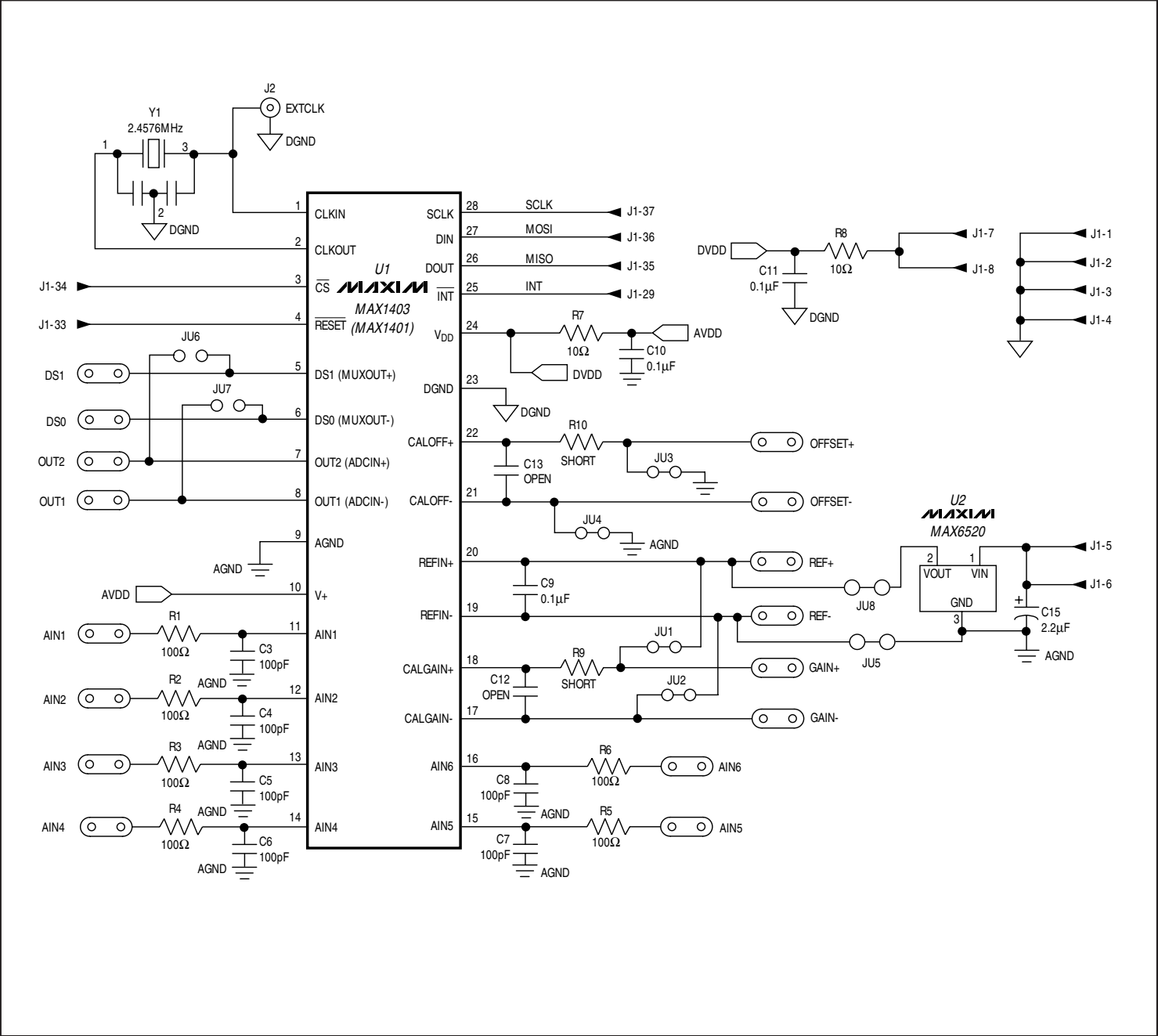

Figure 1. MAX1403 EV Kit Schematic

MAX1403 EV System

Evaluates: MAX1401/MAX1403

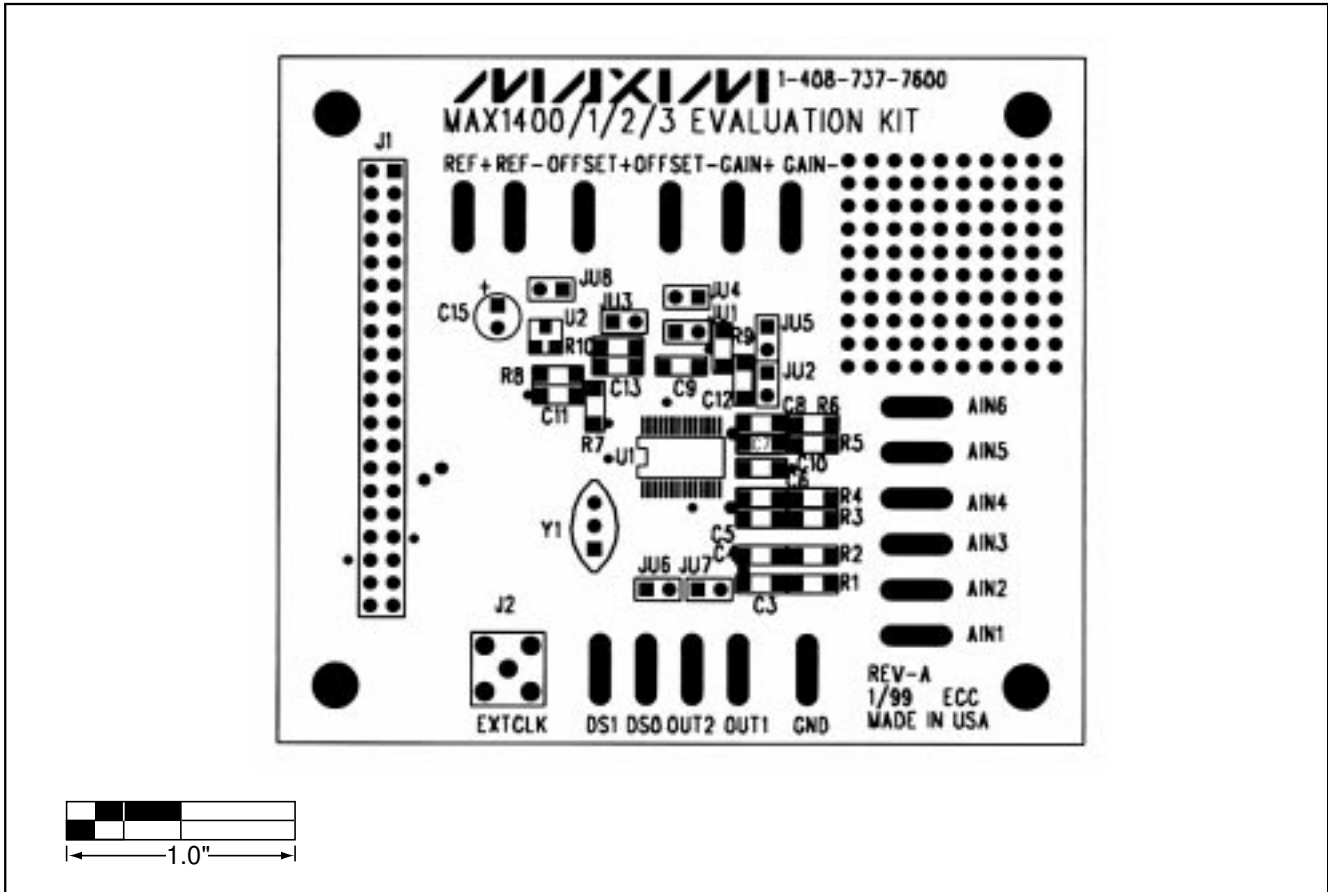

Figure 2. MAX1403 EV Kit Component Placement Guide—Component Side

MAX1403 EV System

Evaluates: MAX1401/MAX1403

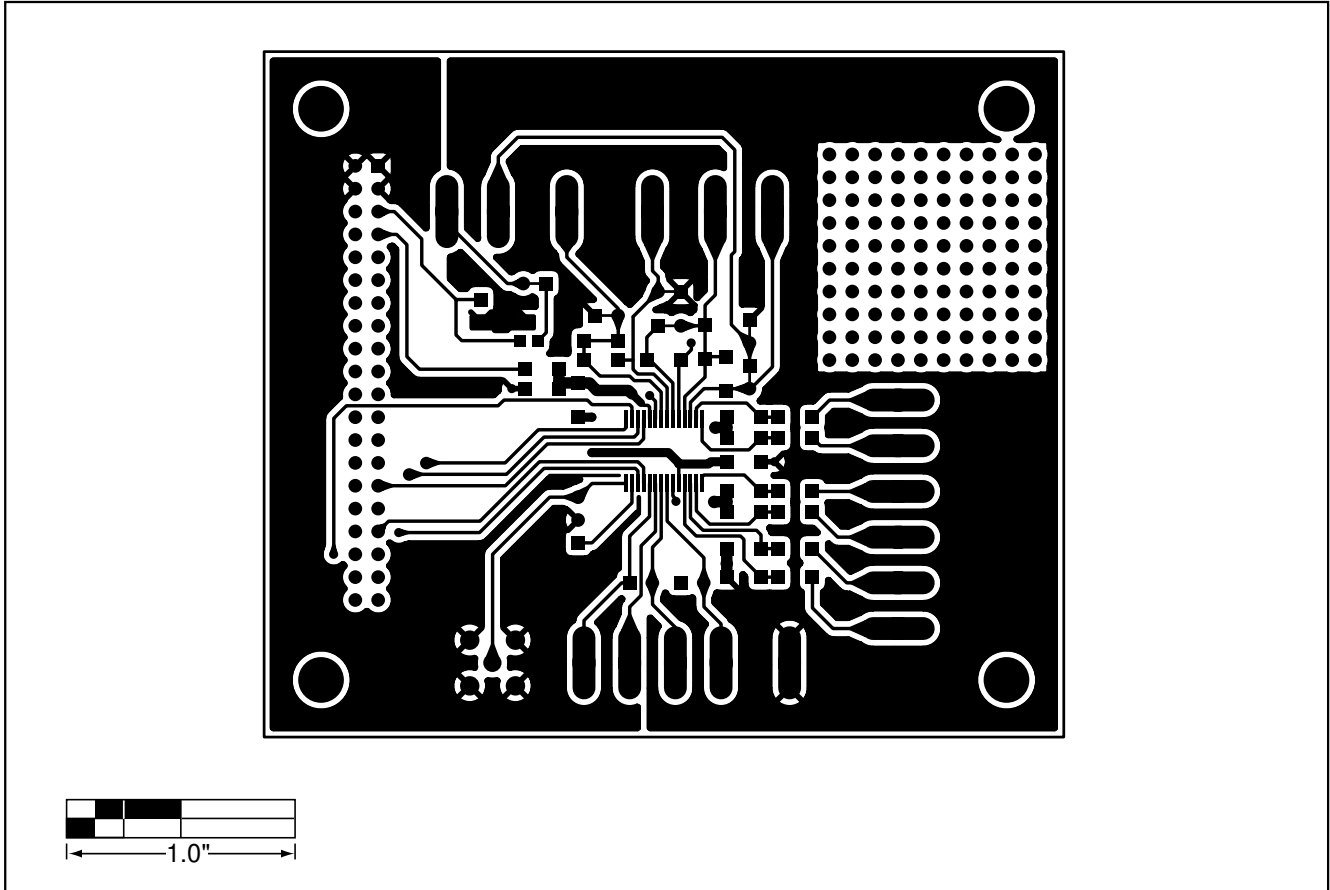

Figure 3. MAX1403 EV Kit PC Board Layout—Component Side

MAX1403 EV System

Evaluates: MAX1401/MAX1403

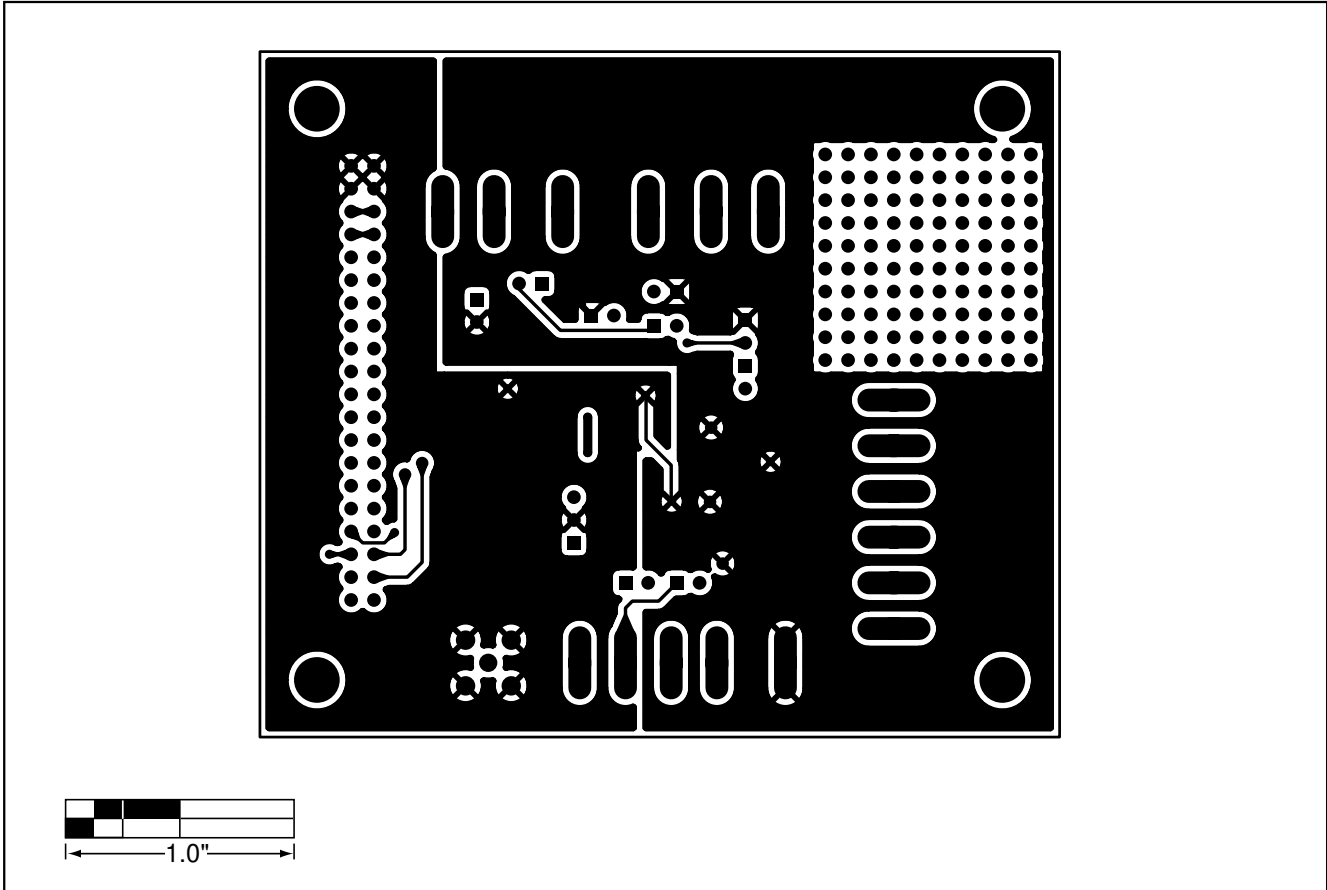

Figure 4. MAX1403 EV Kit PC Board Layout—Solder Side

MAX1403 EV System

Evaluates: MAX1401/MAX1403

NOTES



68L11D Module

68L11D Module

General Description

The 68L11D module is an assembled and tested PC board intended for use with Maxim's low-voltage data-acquisition evaluation kits (EV kits). The module uses Motorola's MC68L11D0FN2 microcontroller (μ C) to collect data samples using the SPI interface. It requires an IBM PC computer and an external DC power supply of +5V to +16V, or as specified in the appropriate EV kit manual.

Maxim's 68L11D module allows customers to evaluate selected Maxim products. It is not intended to be a microprocessor development platform, and Maxim does not support such use.

Getting Started

All system components are guaranteed by their various manufacturers over the +3V to +3.6V power-supply range. Not all system components are guaranteed over the entire 2.5V to 5V V_{DD} power-supply adjustment range. Verify correct operation using the following procedures:

- 1) Connect a +5V DC power source (16V max) to the μ C module at the terminal block located next to the on/off switch, in the upper-right corner of the μ C module. Turn the power switch on.
- 2) Connect a cable from the computer's serial port to the μ C module. If using a 9-pin serial port, use a straight-through, 9-pin, female-to-male cable. If the only available serial port uses a 25-pin connector, a standard 25-pin to 9-pin adapter is required.
- 3) Start the evaluation kit software on the IBM PC. When the program asks which port the μ C module is connected to, press the space bar until the correct port is highlighted, and then press ENTER. The software will be in terminal-emulation mode. (If using a generic terminal-emulation program instead of Maxim EV kit software, select 1200 baud, eight-bit character, no parity, one stop bit. Send a space character to start the monitor program.)
- 4) Adjust trim potentiometer R2 for the desired V_{DD} supply voltage. Measure V_{DD} between test point TP1 and ground. The mounting hole next to R2 is grounded.
- 5) To verify correct system operation, press the ESC key, type a capital "T", and then select the count-down memory test. If the memory test fails or any other malfunction is reported, the V_{DD} voltage is too low; increase V_{DD} and repeat from step 4.
- 6) Turn the power switch off and connect the μ C board to an appropriate Maxim EV kit board.

Component List

DESIGNATION	QTY	DESCRIPTION
C1, C2	2	22pF ceramic capacitors
C3	1	0.01 μ F ceramic capacitor
C4–C9, C12–C18	13	0.1 μ F ceramic capacitors
C10, C11	2	22 μ F, 20V tantalum capacitors
D1	1	1N4001 diode
J1	1	40-pin, right-angle header
J2	1	2-circuit terminal block
J3	1	DB9 right-angle socket
JU1, JU2	2	Open
LED1	1	Light-emitting diode
R1	1	10M Ω , 5% resistor
R2	1	100k Ω potentiometer
R3	1	274k Ω , 1% resistor
R4	1	133k Ω , 1% resistor
R5	1	200 Ω , 5% resistor
R6	1	10k Ω SIP resistor pack, pin 1 common
SW1	1	Slide switch
SW2	1	Momentary push-button switch
U1	1	Motorola MC68L11D0FN2
U2	1	Maxim MAX3232CSE
U3	1	74HC00
U4	1	Maxim MAX667CSA
U5	1	32k x 8 static RAM 28-pin socket Motorola MCM6306DJ15
U10	1	28-pin socket
U6	1	74HCT245
U7	1	Maxim MAX708RCSA
U8	1	74HC573
U9	1	74HC139
U10	1	3V, 8k x 8 ROM
Y1	1	8MHz crystal



68L11D Module

Detailed Description

Power Requirements

The 68L11D module draws its power from a user-supplied power source connected to terminal block J2. Note the positive and negative markings on the board. Nominal input voltages should be between +5V and +16V. The input current requirement for the 68L11D module is typically 20mA plus the current drawn by the evaluation kit (EV kit).

The V_{DD} supply is set by U4, a MAX667 low-dropout CMOS regulator. Trim potentiometer R2 sets the supply voltage, with an adjustment range of approximately 2.5V to 5V. Although the board is designed primarily for 3V applications, all of the circuitry is rated to withstand 5V levels.

68L11D Microcontroller (μ C) Module Hardware

U1 is Motorola's 68L11D μ C. Contact Motorola for μ C information, development, and support.

A MAX708R supervisory circuit on the module monitors the V_{DD} logic supply, generates the power-on reset, and produces a reset pulse whenever the manual reset button (SW2) is pressed. Note that the MAX708R resets the CPU if the supply voltage falls below 2.66V.

The module provides 32kbytes of external CMOS static RAM (U5).

The 74HCT245 octal buffer (U6) provides access to an eight-bit port on the 40-pin interface connector. This memory-mapped port consists of Intel-compatible read and write strobes, four chip selects, four address LSB's, and eight data bits. Table 3 lists the address ranges for each of the memory-mapped elements on the 68L11D module.

The MAX3232 is a 3V-powered, RS-232 interface voltage-level shifter. Its built-in charge pump uses external capacitors to generate the output voltages necessary to drive RS-232 lines.

The 20 x 2-pin header (J1) connects the 68L11D module to a Maxim EV kit. Table 2 lists the function of each pin. Use the 68L11D module only with EV kits that are designed to support it, and download only code that is targeted for the Maxim 68L11D module. Downloading incorrect object code into the 68L11D module will produce unpredictable results.

The 8k x 8 boot ROM (U10) checks the system and waits for commands from the host. Refer to the EV kit manual for specific startup procedures.

Software

All software is supplied on a disk with the EV kit. Software operating instructions are included in the EV kit manual.

Serial Communications

J3 is an RS-232 serial port, designed to be compatible with the IBM PC 9-pin serial port. Use a straight-through DB9 male-to-female cable to connect J3 to the IBM PC serial port. If the only available serial port has a 25-pin connector, use a standard 25-pin to 9-pin adapter. Table 1 shows J3's pinout. The hardware-handshake lines are used by the evaluation software to confirm that the EV kit is connected to the correct serial port.

Table 1. Serial Communications Port J3

PIN	NAME	FUNCTION
1	DCD	Handshake; hard-wired to DTR and DSR
2	RXD	RS-232-compatible data output from 68L11D module
3	TXD	RS-232-compatible data input to 68L11D module
4	DTR	Handshake; hard-wired to DCD and DSR
5	GND	Signal ground connection
6	DSR	Handshake; hard-wired to DCD and DTR
7	RTS	Handshake; hard-wired to CTS
8	CTS	Handshake; hard-wired to RTS
9	None	Unused

68L11D Module

68L11D Module

Table 2. 40-Pin Data-Connector Signals

PIN	NAME	FUNCTION
1–4	GND	Ground
5, 6	V ₊₊	Unregulated input voltage
7, 8	V _{DD}	V _{DD} from on-board MAX667 regulator
9	\overline{RD}	Read strobe
10	\overline{WR}	Write strobe
11	$\overline{CS0}$	Chip select for 8000-8FFF
12	$\overline{CS1}$	Chip select for 9000-9FFF
13	$\overline{CS2}$	Chip select for A000-AFFF
14	$\overline{CS3}$	Chip select for B000-BFFF
15	ADDR0	Address bit 0 (LSB)
16	ADDR1	Address bit 1
17	ADDR2	Address bit 2
18	ADDR3	Address bit 3
19	DB0	Data bus bit 0 (LSB)
20–26	DB1–DB7	Data bus bits 1–7
27	PA0/IC3	General I/O port bit 0 (LSB)
28	PA1/IC2	General I/O port
29	PA2/IC1	General I/O port
30	PA3/IC4/OC5	General I/O port
31	PA4/OC4	General I/O port
32	PA5/OC3	General I/O port
33	PA6/OC2	General I/O port
34	PA7/OC1/PAI	General I/O port MSB
35	MISO	SPI master-in, slave-out
36	MOSI	SPI master-out, slave-in
37	SCK	SPI serial clock
38	RESERVED	Reserved for factory use
39	E	System E-clock output
40	\overline{SS}	SPI slave-select input

Table 3. 68L11D Module Memory Map

ADDRESS RANGE (HEX)	FUNCTION
0000-7FFF	User RAM area (U5)
8000-8FFF	External chip-select 0 (J1 pin 11)
9000-9FFF	External chip-select 1 (J1 pin 12)
A000-AFFF	External chip-select 2 (J1 pin 13)
B000-BFFF	External chip-select 3 (J1 pin 14)
C000-C03F	Unused
C040-C0FF	Internal RAM (U1)
C100-CFFF	Unused
D000-D03F	Internal register area (U1)
D040-DFFF	Unused
E000-FFFF	Boot ROM (U10)

68L11D Module

68L11D Module

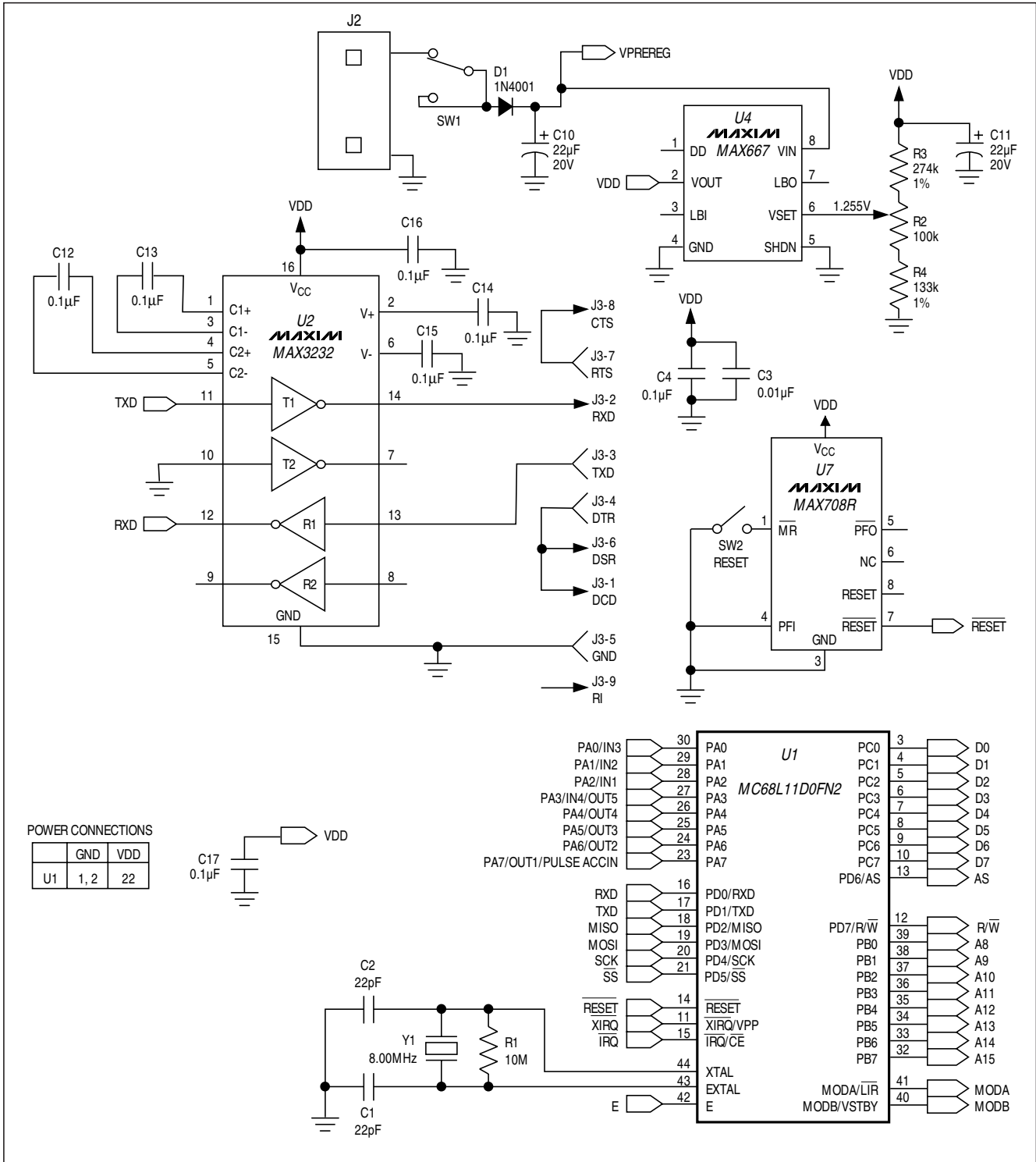

Figure 1. 68L11D Module Schematic Diagram

68L11D Module

68L11D Module

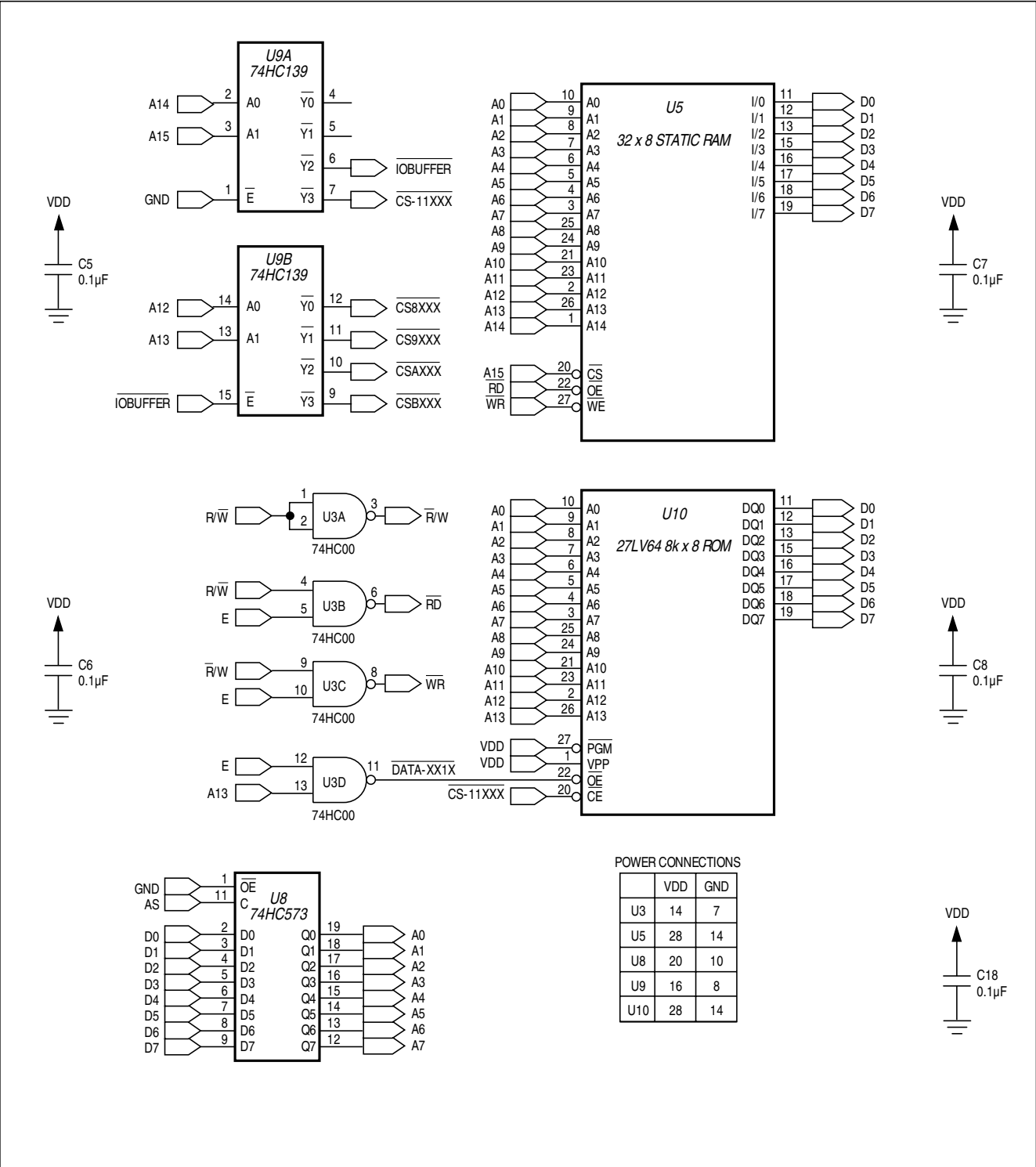

Figure 1. 68L11D Module Schematic Diagram (continued)

68L11D Module

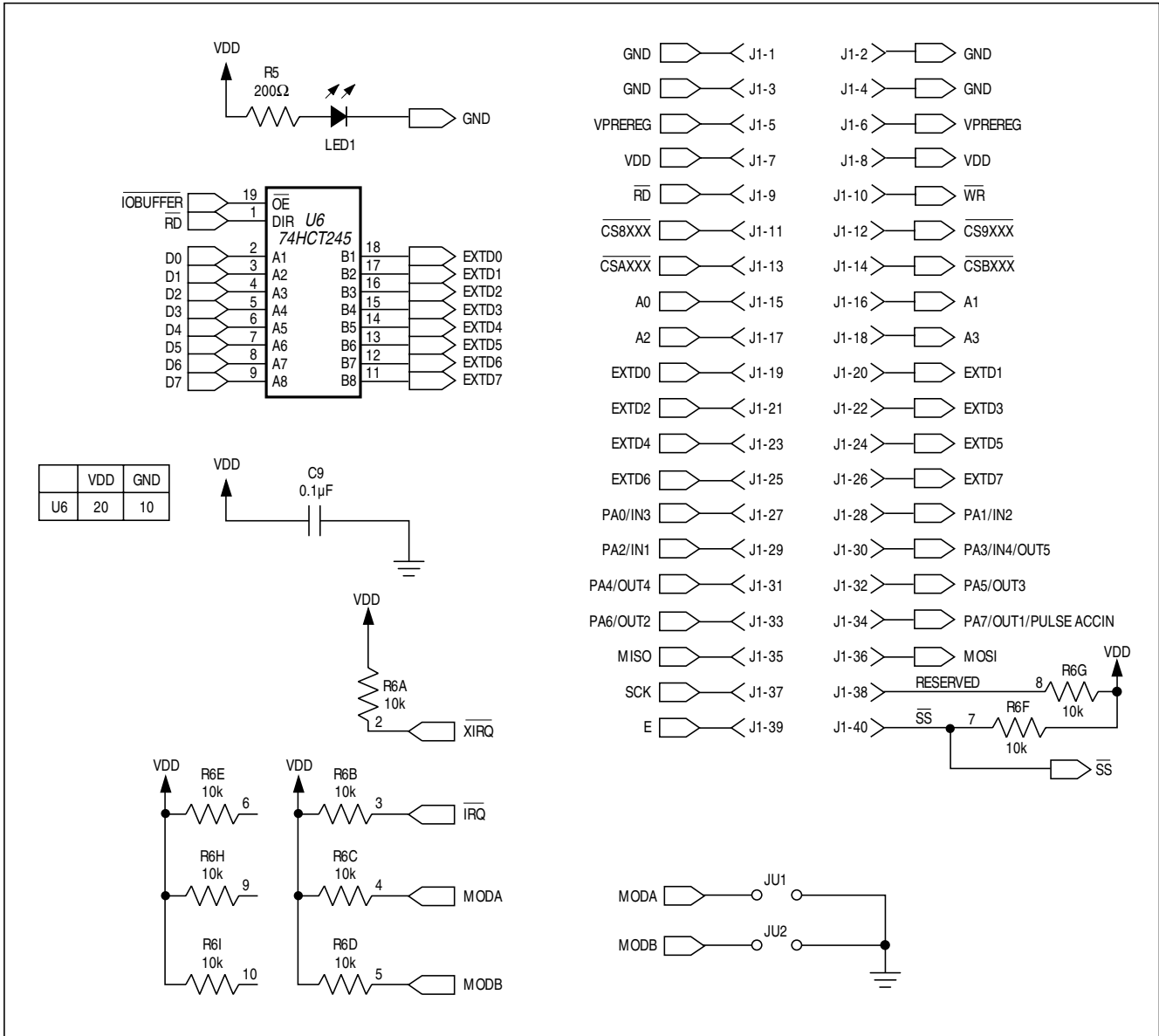

Figure 1. 68L11D Module Schematic Diagram (continued)

68L11D Module

68L11D Module

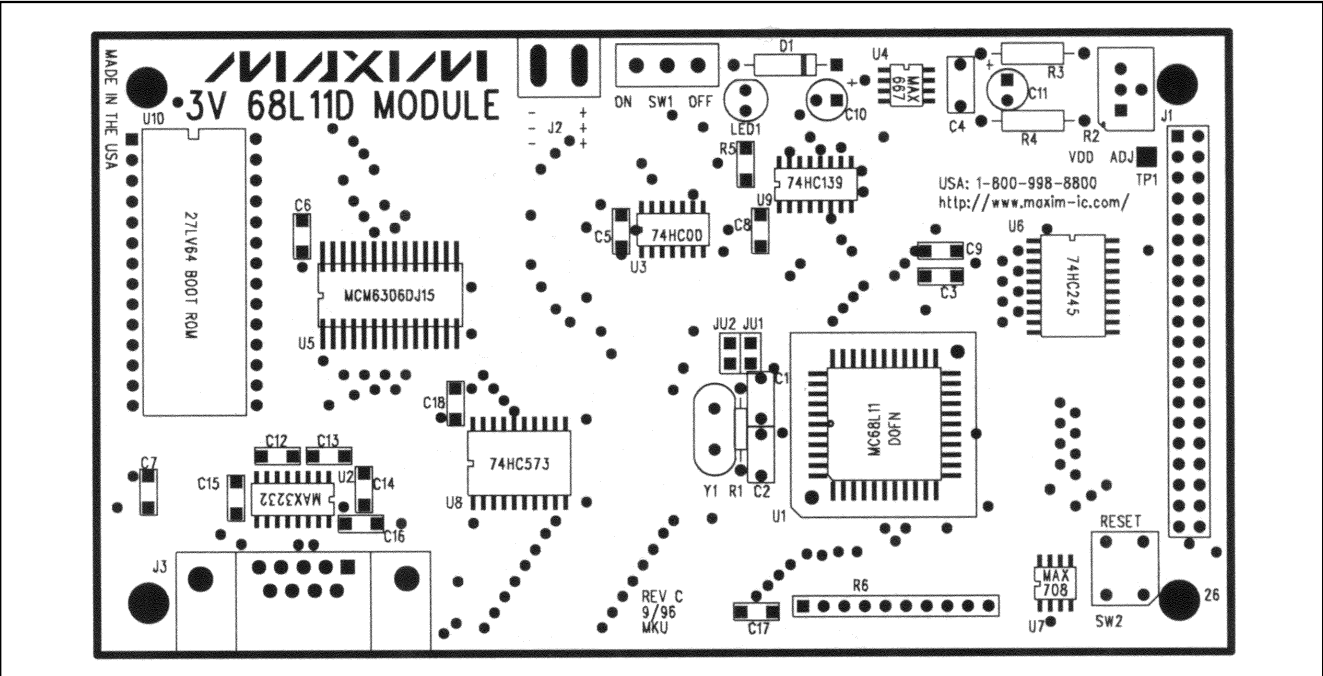

Figure 2. 68L11D Module Component Placement Guide

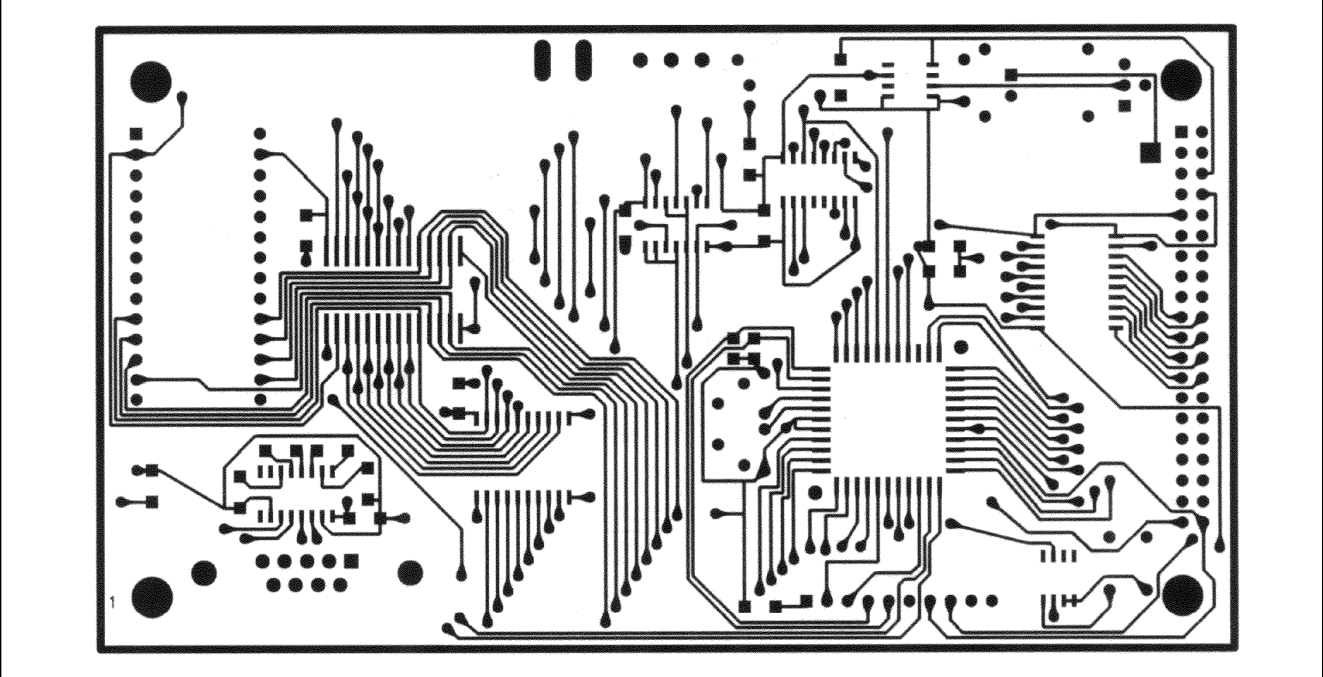

Figure 3. 68L11D Module PC Board Layout—Component Side

68L11D Module

68L11D Module

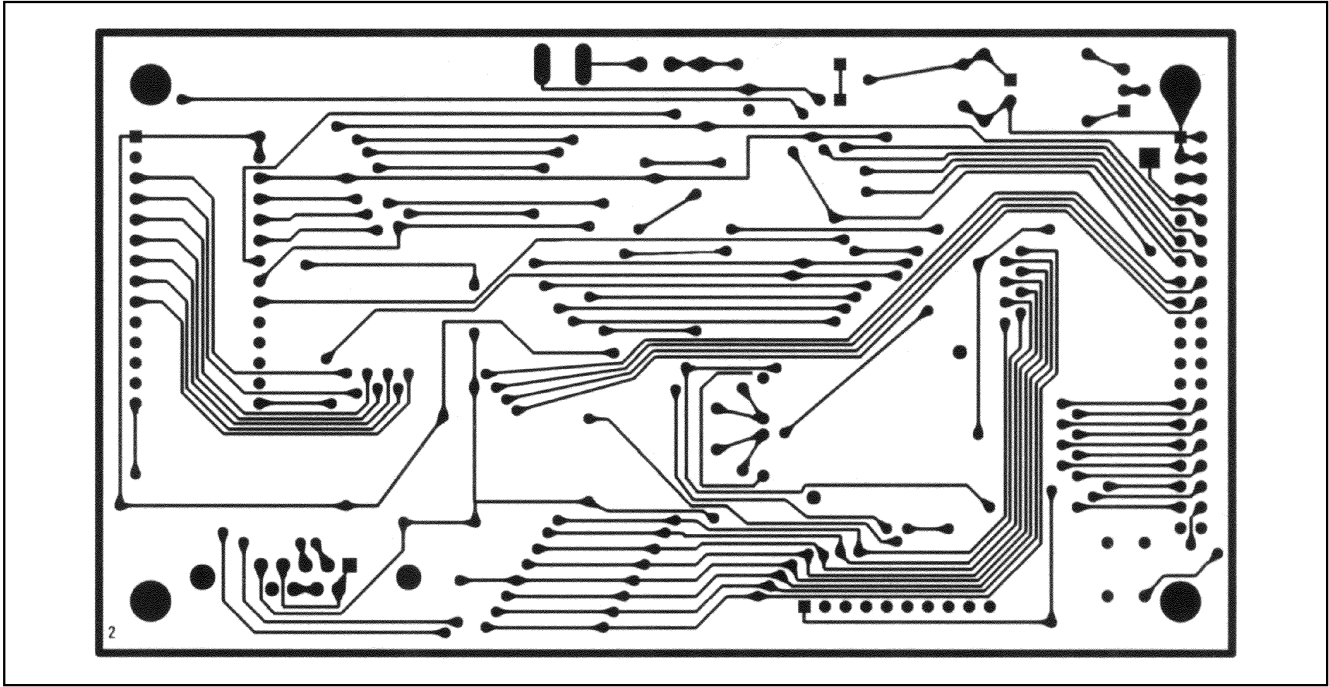

Figure 4. 68L11D Module PC Board Layout—Solder Side

Maxim cannot assume responsibility for use of any circuitry other than circuitry entirely embodied in a Maxim product. No circuit patent licenses are implied. Maxim reserves the right to change the circuitry and specifications without notice at any time.

8 _____ Maxim Integrated Products, 120 San Gabriel Drive, Sunnyvale, CA 94086 408-737-7600