



Chipsmall Limited consists of a professional team with an average of over 10 year of expertise in the distribution of electronic components. Based in Hongkong, we have already established firm and mutual-benefit business relationships with customers from,Europe,America and south Asia,supplying obsolete and hard-to-find components to meet their specific needs.

With the principle of "Quality Parts,Customers Priority,Honest Operation,and Considerate Service",our business mainly focus on the distribution of electronic components. Line cards we deal with include Microchip,ALPS,ROHM,Xilinx,Pulse,ON,Everlight and Freescale. Main products comprise IC,Modules,Potentiometer,IC Socket,Relay,Connector.Our parts cover such applications as commercial,industrial, and automotives areas.

We are looking forward to setting up business relationship with you and hope to provide you with the best service and solution. Let us make a better world for our industry!



Contact us

Tel: +86-755-8981 8866 Fax: +86-755-8427 6832

Email & Skype: info@chipsmall.com Web: www.chipsmall.com

Address: A1208, Overseas Decoration Building, #122 Zhenhua RD., Futian, Shenzhen, China



MAX14430–MAX14432 Evaluation Kit

Evaluates: MAX14430–MAX14432

General Description

The MAX14430-MAX14432 evaluation kit (EV kit) provides a proven design to evaluate the MAX14430-MAX14432 four-channel unidirectional digital isolators. Three types of evaluation boards are available to support different channel direction configurations of the MAX14430-MAX14432 family. All evaluation boards support the narrow-body 16-pin SOIC package type. See [Table 1](#) for EV kit options.

The EV kit should be powered from two independent isolated power supplies with nominal output voltage in range from 1.71V to 5.5V. For evaluating the electrical parameters of the device without any isolation between the two sides, a single power supply can also be used.

The MAX14430FSEVKIT# comes populated with a MAX14430FASE+, but can also be used to evaluate the following digital isolators:

MAX14430BASE+
MAX14430CASE+
MAX14430EASE+

The MAX14431FSEVKIT# comes populated with the MAX14431FASE+, but can also be used to evaluate the following digital isolators:

MAX14431BASE+, MAX14431CASE+
MAX14431EASE+, MAX14431RASE+
MAX14431SASE+, MAX14431UASE+,
MAX14431VASE+

The MAX14432FSEVKIT# comes populated with the MAX14432FASE+, but can also be used to evaluate the following digital isolators:

MAX14432BASE+
MAX14432CASE+
MAX14432EASE+

Table 1. EV Kit Options

EV KIT PART NUMBER	TARGET DEVICE	PACKAGE TYPE	COMMENT
MAX14430FSEVKIT#	MAX14430FASE+	16-SOIC narrow-body	200Mbps IC populated
MAX14431FSEVKIT#	MAX14431FASE+	16-SOIC narrow-body	200Mbps IC populated
MAX14432FSEVKIT#	MAX14432FASE+	16-SOIC narrow-body	200Mbps IC populated

Features

- Broad Range of Data Transfer Rates (from DC to 200Mbps)
- Four Unidirectional Channels with 3 Different Channel Direction Configurations
- SMA Connectors for Easy Connection to External Equipment
- Wide Power Supply Voltage Range from 1.71V to 5.5V
- Guaranteed Up to 3.75kV_{RMS} Isolation for the Narrow-Body SOIC Package for 60s

[Ordering Information](#) appears at end of data sheet.

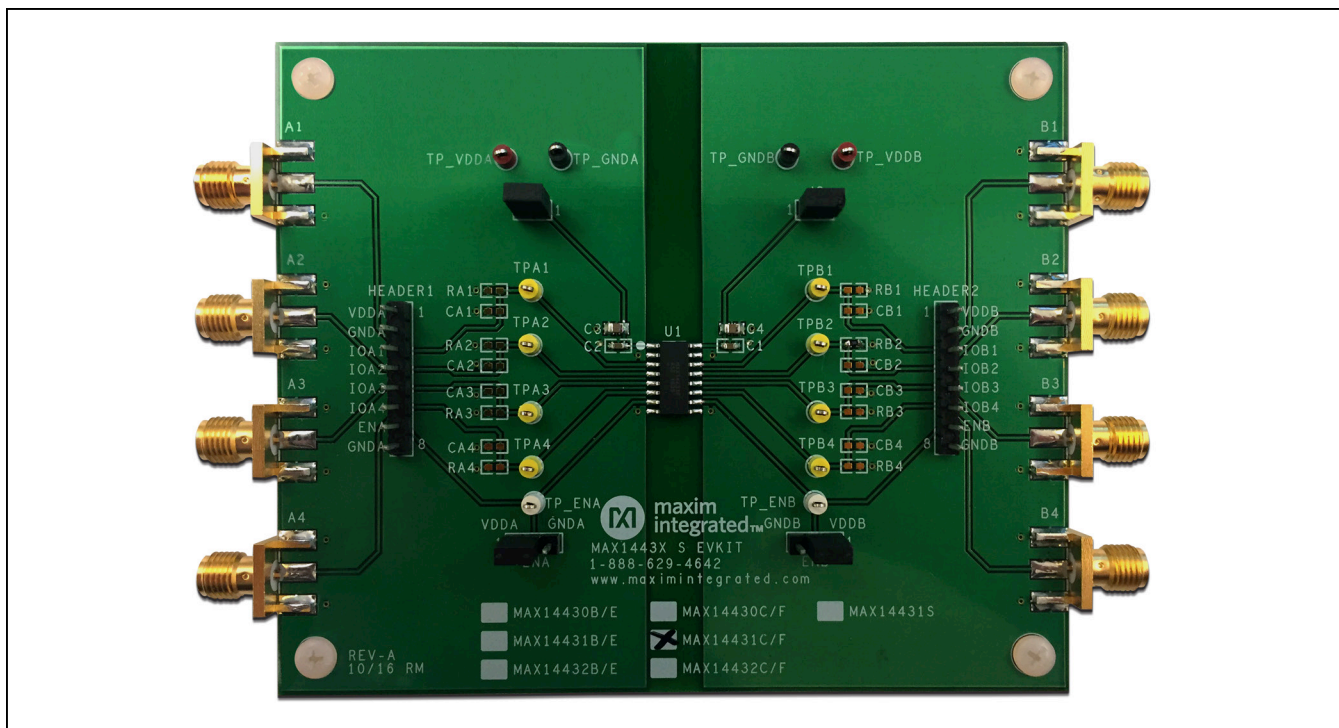

Figure 1. Narrow-Body MAX14431FSEVKIT#

Quick Start

Required Equipment

- MAX14430FS, MAX14431FS, or MAX14432FS EV kit
- Two DC power supplies with output range of 1.71V to 5.5V
- Signal/function generator
- Oscilloscope

Procedure

The MAX14430FS, MAX14431FS, and MAX14432FS EV kits are fully assembled and ready for evaluation. For manual verification follow the steps below to verify board functionality:

- 1) Verify jumper settings. See [Table 2](#) for all shunt positions.
 - J1 and J2 are closed.
 - Jumper ENA is either in 1-2 position if U1 ENA (pin 7) has active-high polarity, or in 2-3 position if U1 $\overline{\text{ENA}}$ (pin 7) has active-low polarity.
 - Jumper ENB is in 1-2 position.

- 2) Connect one DC power supply between the EV kit's TP_VDDA and TP_GNDA test points; connect the other DC power supply between TP_VDDB and TP_GNDB test points.
- 3) Set both DC power supply outputs between 1.71V and 5.5V, and then enable the power supply outputs. **Note:** *It is also possible to power the EV kits from a single power supply to test electrical parameters but this invalidates the digital isolation of the IC.*
- 4) Connect the signal/function generator to the SMA connector or test point of side A and observe the isolated signal on the corresponding side B output, using an oscilloscope.

Table 2. MAX1443XS EV Kits Board Connectors and Shunt Positions

CONNECTOR	SHUNT POSITION	DESCRIPTION
SIDE A		
HEADER1	1	Test point or input header for V _{DDA}
	2	Test point or input header for GNDA
	3	Test point or input header for I/O; same as A1 SMA
	4	Test point or input header for I/O; same as A2 SMA
	5	Test point or input header for I/O; same as A3 SMA
	6	Test point or input header for I/O; same as A4 SMA
	7	Test point or input header for side A enable; same as ENA jumper pin 2
	8	Test point or input header for GNDA
A1 (SMA)	n/a	I/O on side A
A2 (SMA)	n/a	I/O on side A
A3 (SMA)	n/a	I/O on side A
A4 (SMA)	n/a	I/O on side A
J1	Open	Use current meter to measure current of side A
	1-2*	Connect power supply to V _{DDA}
ENA	1-2*	Connect side A enable pin to V _{DDA} ; side A outputs are enabled if ENA is active-high or high-impedance if active-low. Default setting on EV kits
	2-3	Connect side A enable pin to GNDA; side A outputs are high-impedance if ENA is active-high or enabled if active-low.

Table 2. MAX1443XS EV Kits Board Connectors and Shunt Positions (continued)

CONNECTOR	SHUNT POSITION	DESCRIPTION
SIDE B		
HEADER2	1	Test point or input header for V_{DDB}
	2	Test point or input header for GNDB
	3	Test point or input header for I/O; same as B1 SMA
	4	Test point or input header for I/O; same as B2 SMA
	5	Test point or input header for I/O; same as B3 SMA
	6	Test point or input header for I/O; same as B4 SMA
	7	Test point or input header for side B enable; same as ENB jumper pin 2
	8	Test point or input header for GNDB
B1 (SMA)	n/a	I/O on side B
B2 (SMA)	n/a	I/O on side B
B3 (SMA)	n/a	I/O on side B
B4 (SMA)	n/a	I/O on side B
J2	Open	Use current meter to measure current of side B
	1-2*	Connect power supply to V_{DDB}
ENB	1-2*	Connect side B enable pin to V_{DDB} ; side B outputs are enabled. Default setting on EV kits
	2-3	Connect side B enable pin to GNDB; side B outputs are high-impedance.

*Default configuration

Table 3. EV Kits Test Points

TEST POINT	DESCRIPTION
SIDE A	
TP_VDDA	Test point for V_{DDA}
TP_GNDA	Test point for GNDA
TPA1	Test point for SMA connector A1
TPA2	Test point for SMA connector A2
TPA3	Test point for SMA connector A3
TPA4	Test point for SMA connector A4
TP_ENA	Test point for jumper ENA pin 2
SIDE B	
TP_VDDB	Test point for V_{DDB}
TP_GNDB	Test point for GNDB
TPB1	Test point for SMA connector B1
TPB2	Test point for SMA connector B2
TPB3	Test point for SMA connector B3
TPB4	Test point for SMA connector B4
TP_ENB	Test point for jumper ENB pin 2

Detailed Description of Hardware

The EV kits are powered from two power supplies as described below.

External Power Supplies

Power to the MAX14430FS, MAX14431FS, and MAX14432FS EV kits are derived from two external sources which can both be between +1.71V and +5.5V. Connect one source between the V_{DDA} and $GNDA$ test points, and the other source between the V_{DDB} and $GNDB$ test points. Each supply can be set independently and can be present over the entire range from 1.71V to 5.5V, regardless of the level or presence of the other supply. The MAX14430–MAX14432 level-shift the data, transmitting them across the isolation barrier.

Four SMA connectors on each side of the board allow easy connections to signal generator(s) and oscilloscope. A typical test setup is shown in [Figure 2](#).

Decoupling Capacitors

Each power supply is decoupled with a 10 μ F ceramic capacitor in parallel with a 0.1 μ F ceramic capacitor, which are placed close to the U1 V_{DDA} or V_{DDB} pin.

Termination

Each input and output has an unpopulated 0603 SMT resistor (RA1-RA4, RB1-RB4) and an unpopulated 0603 SMT capacitor (CA1-CA4, CB1-CB4) to $GND_{_}$ to allow termination based on customer requirements.

Shunt Positions

Jumpers J1 and J2 are installed between the external power supplies and U1 power supply pins to allow supply current measurement. Uninstall the J1 and J2 shunts and connect current meters on both side A and side B to measure the MAX14430–MAX14432 supply current.

Jumper ENA is provided to enable or disable the side A of the isolator channels. To enable the devices with active-high enable pin on the side A (MAX1443_B/C/E/F), connect the ENA shunt to V_{DDA} . To enable the devices with active-low enable pin on the side A (MAX14431R/S/U/V), connect the ENA shunt to $GNDA$. The side A outputs are high-impedance when disabled.

Jumper ENB is provided to enable or disable the side B of the isolator channels. Connect the ENB shunt to V_{DDB} to enable the side B channels, or connect to $GNDB$ to disable the side B channels. The side B outputs are high-impedance when disabled. See [Table 2](#) for all shunt positions.

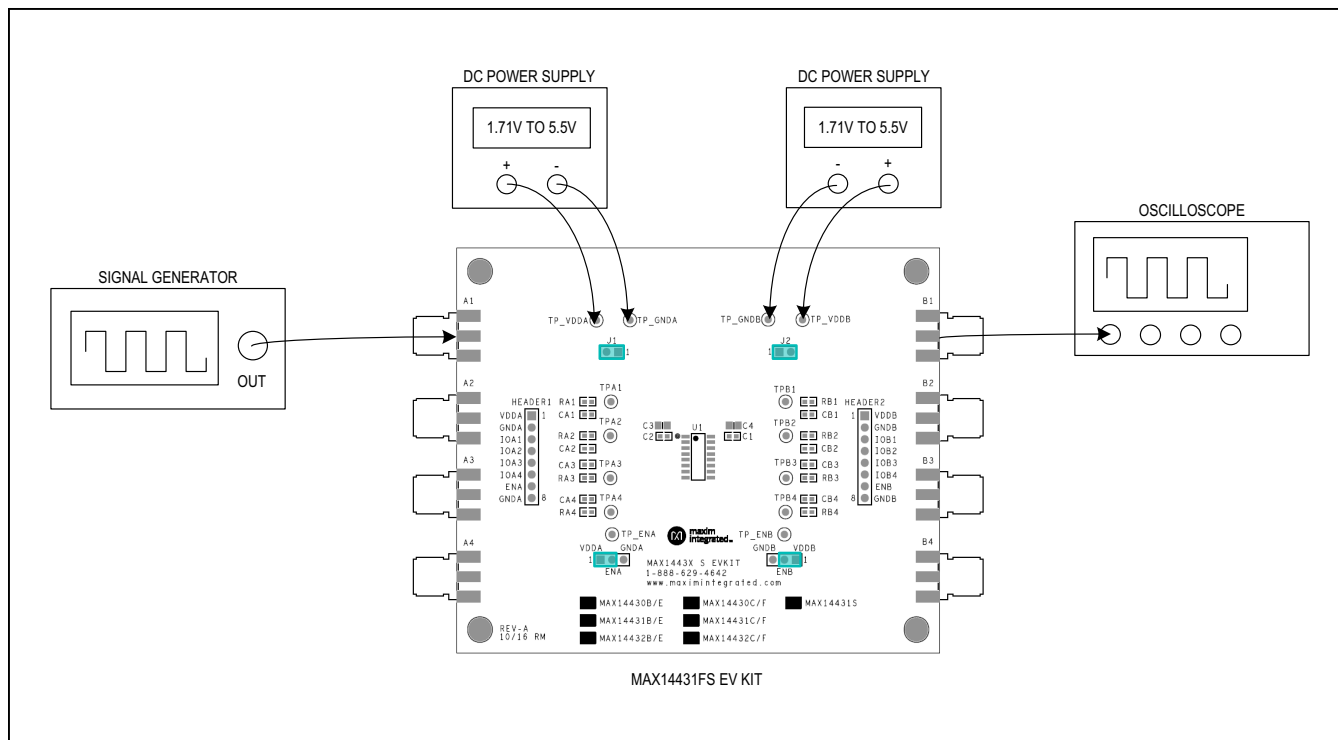

Figure 2. MAX14431FS EV Kit Typical Test Setup

Ordering Information

PART	TYPE
MAX14430FSEVKIT#*	EV kit with installed MAX14430FASE+
MAX14431FSEVKIT#*	EV kit with installed MAX14431FASE+
MAX14432FSEVKIT#	EV kit with installed MAX14432FASE+

#Denotes RoHS compliant.

*Future Product—Contact factory for availability.

MAX14430–MAX14432 EV Kit Bill of Materials

ITEM	REF_DES	DNI/ DNP	QTY	MFG PART #	MFG	VALUE	DESCRIPTION
1	A1-A4, B1-B4	-	8	142-0701-851	JOHNSON COMPONENTS	142-0701-851	CONNECTOR; END LAUNCH JACK RECEPTACLE; BOARDMOUNT; STRAIGHT THROUGH; 2PINS;
2	C1, C2	-	2	ECJ-1VB1H104K; GRM188R71H104KA; CGJ3E2X7R1H104K080AA; C1608X7R1H104K080AA; CL10B104KB8NFN; CL10B104KB8NNN	PANASONIC; MURATA; TDK; SAMSUNG	0.1UF	CAPACITOR; SMT (0603); CERAMIC CHIP; 0.1UF; 50V; TOL=10%; TG=-55 DEGC TO +125 DEGC; TC=X7R;
3	C3, C4	-	2	CL21B106K0QNNN	SAMSUNG ELECTRONICS	10UF	CAPACITOR; SMT (0805); CERAMIC CHIP; 10UF; 16V; TOL=10%; TG=-55 DEGC TO +125 DEGC; TC=X7R
4	ENA, ENB	-	2	PEC03SAAN	SULLINS	PEC03SAAN	CONNECTOR; MALE; THROUGH HOLE; BREAKAWAY; STRAIGHT; 3PINS
5	HEADER1, HEADER2	-	2	PEC08SAAN	SULLINS ELECTRONICS CORP.	PEC08SAAN	CONNECTOR; MALE; THROUGH HOLE; .100IN CONTACT CENTER; MALE BREAKAWAY HEADER ; STRAIGHT; 8PINS
6	J1, J2	-	2	PEC02SAAN	SULLINS	PEC02SAAN	CONNECTOR; MALE; THROUGH HOLE; BREAKAWAY; STRAIGHT; 2PINS
7	MTH1-MTH4	-	4	EVKIT_STANDOFF_4- 40_3/8	?	EVKIT_STAND OFF_4-40_3/8	KIT; ASSY-STANDOFF 3/8IN; 1PC. STANDOFF/FEM/HEX/4-40IN/(3/8IN)/NYLON; 1PC. SCREW/SLOT/PAN/4-40IN/(3/8IN)/NYLON
8	SU1-SU4	-	4	STC02SYAN	SULLINS ELECTRONICS CORP.	STC02SYAN	TEST POINT; JUMPER; STR; TOTAL LENGTH=0.256IN; BLACK; INSULATION=PBT CONTACT=PHOSPHOR BRONZE; COPPER PLATED TIN OVERALL
9	TPA1-TPA4, TPB1- TPB4	-	8	5004	KEYSTONE	N/A	TEST POINT; PIN DIA=0.1IN; TOTAL LENGTH=0.3IN; BOARD HOLE=0.04IN; YELLOW; PHOSPHOR BRONZE WIRE SILVER PLATE FINISH;
10	TP_ENA, TP_ENB	-	2	5002	KEYSTONE	N/A	TEST POINT; PIN DIA=0.1IN; TOTAL LENGTH=0.3IN; BOARD HOLE=0.04IN; WHITE; PHOSPHOR BRONZE WIRE SILVER;

MAX14430-MAX14432 EV Kit Schematic

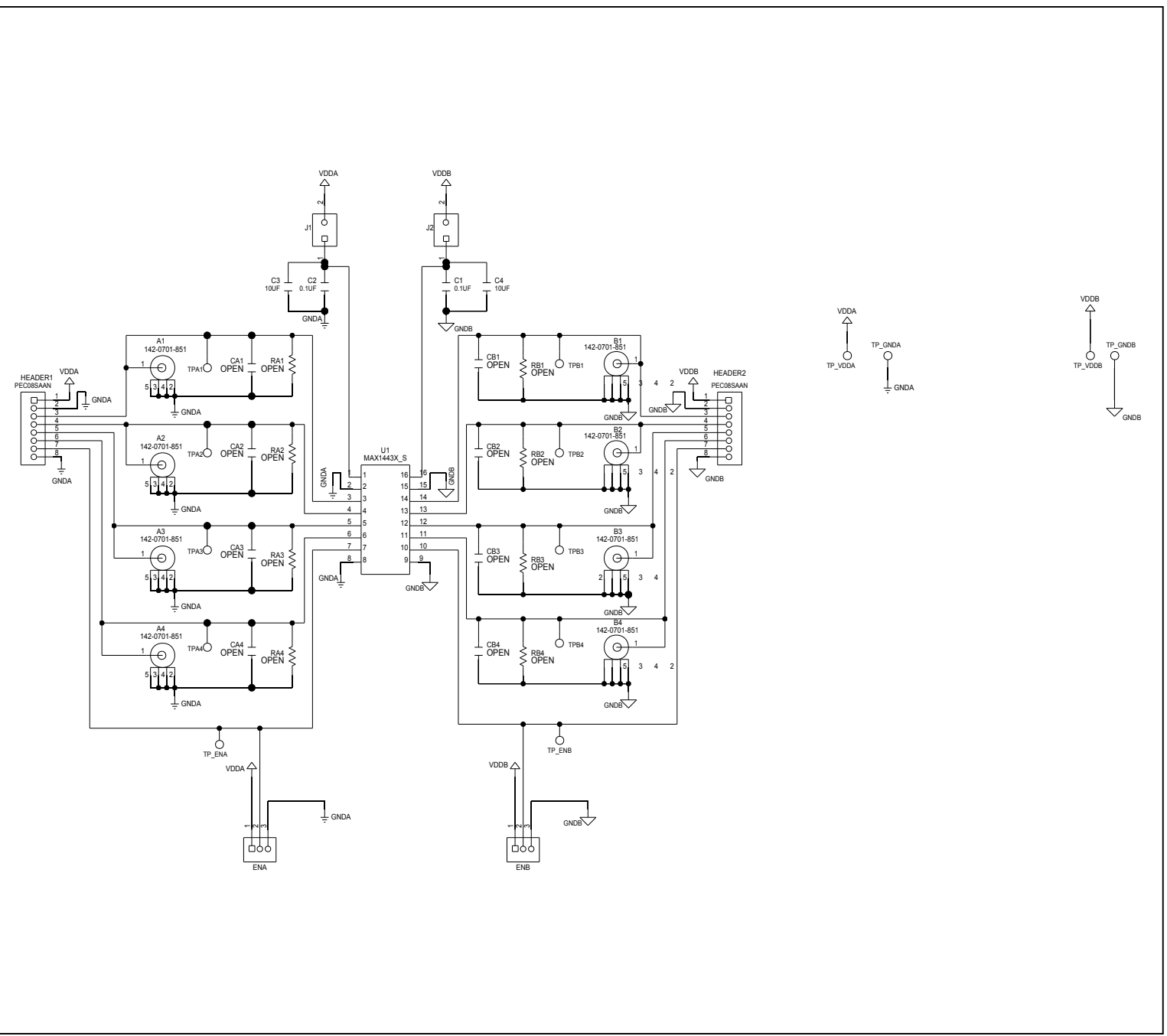

MAX14430–MAX14432 EV Kit PCB Layout Diagrams

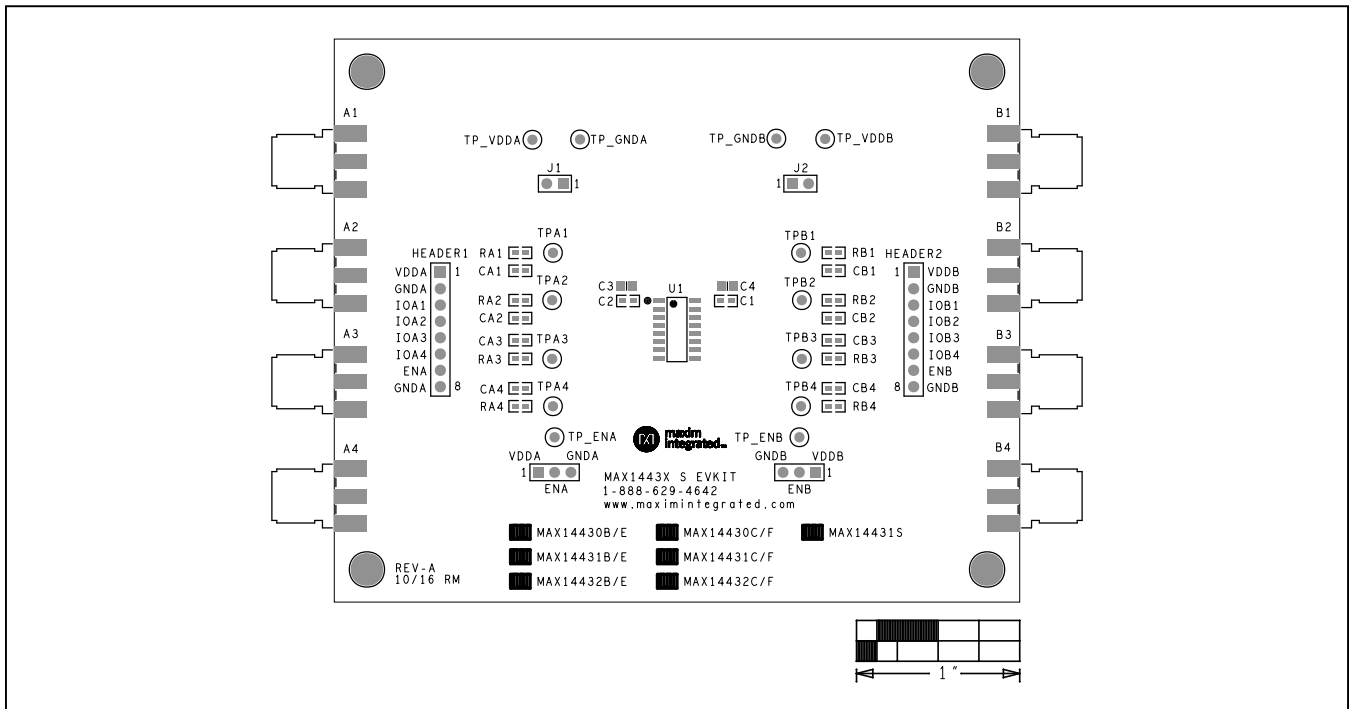

MAX14430–MAX14432 EV Kit—Top Silkscreen

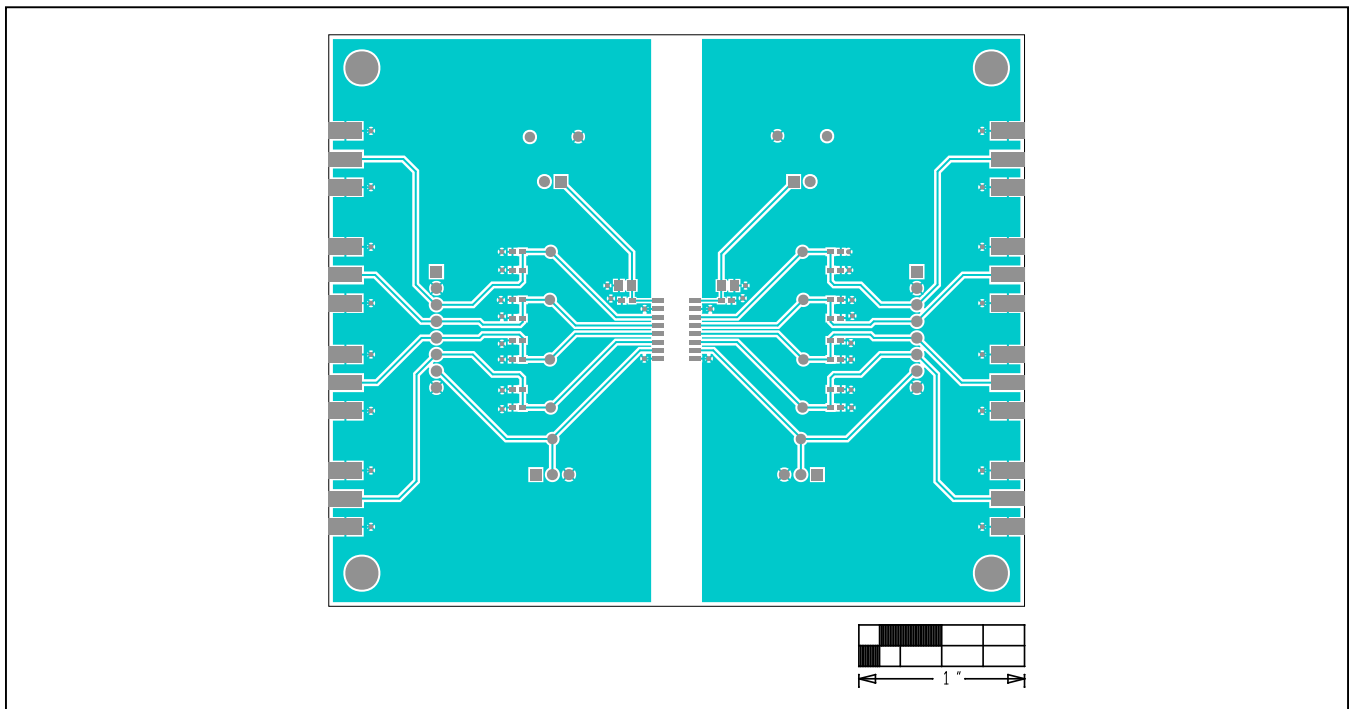

MAX14430–MAX14432 EV Kit—Top

MAX14430–MAX14432 EV Kit PCB Layout Diagrams (continued)

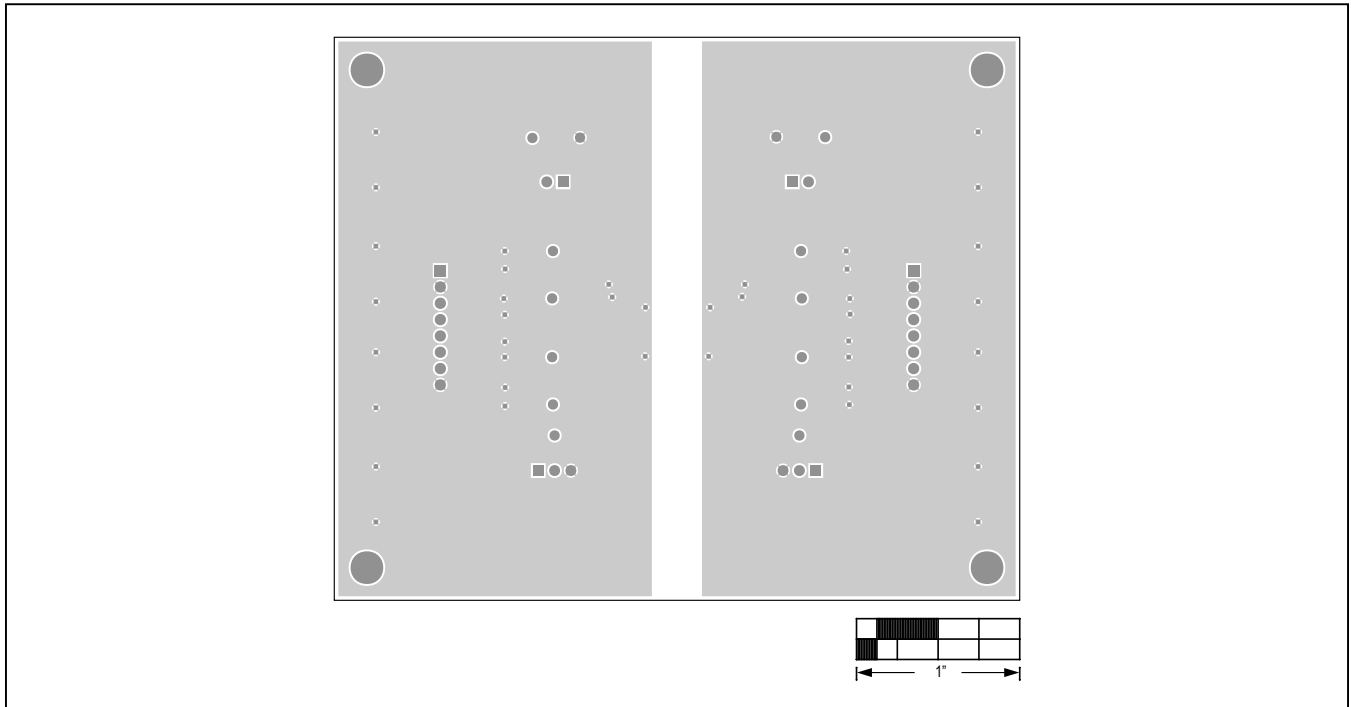

MAX14430–MAX14432 EV Kit—L2 GND

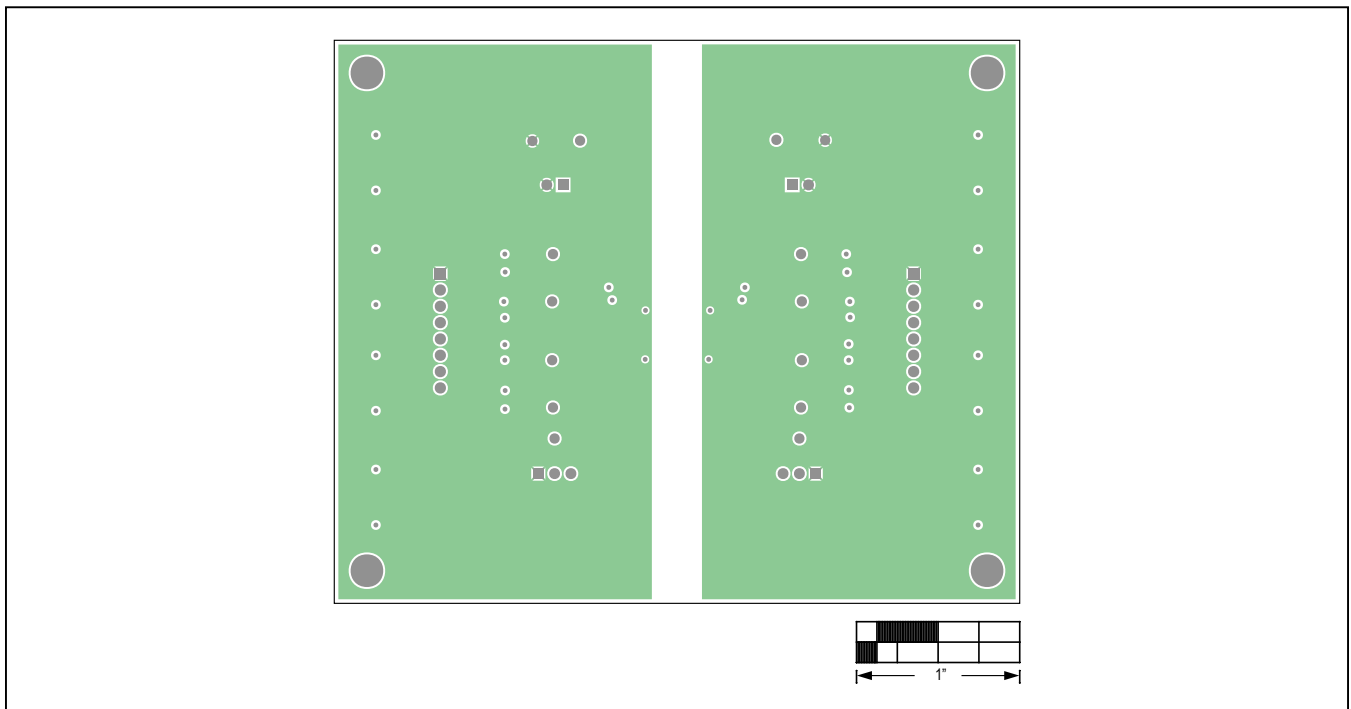

MAX14430–MAX14432 EV Kit—L3 PWR

MAX14430–MAX14432 EV Kit PCB Layout Diagrams (continued)

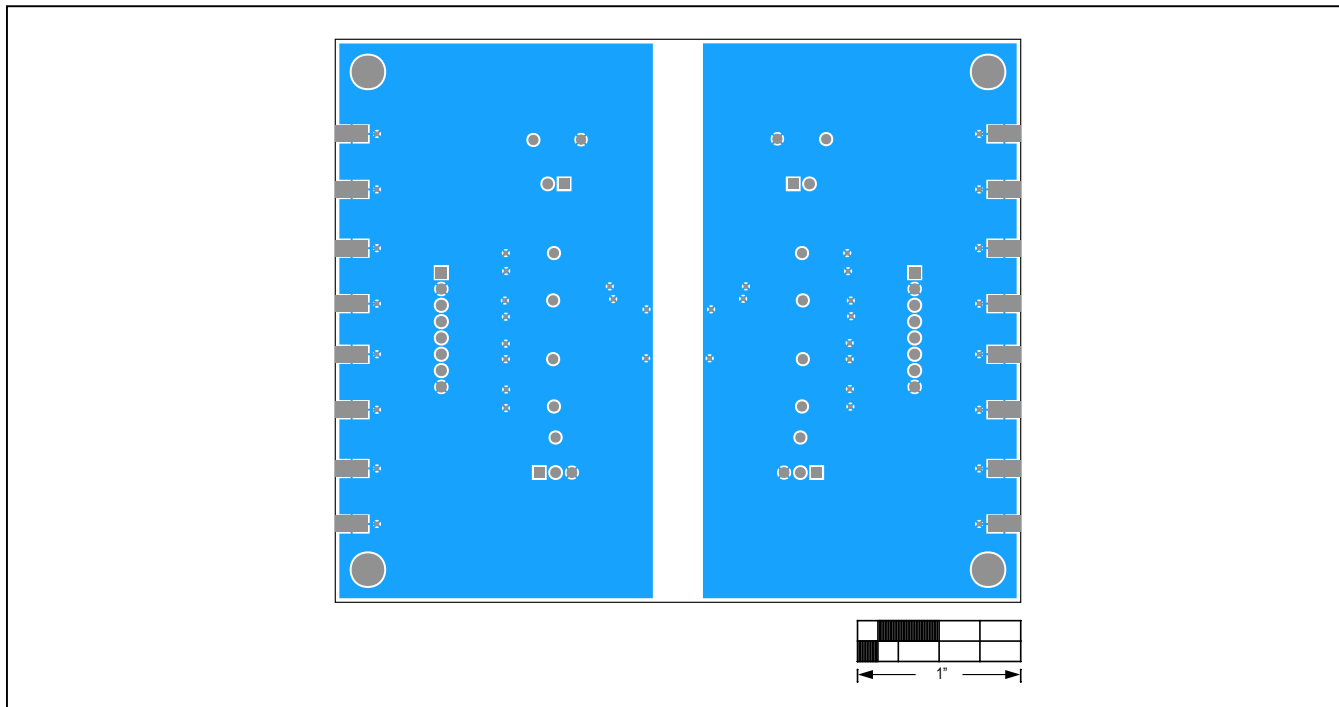

MAX14430–MAX14432 EV Kit—Bottom

Revision History

REVISION NUMBER	REVISION DATE	DESCRIPTION	PAGES CHANGED
0	2/18	Initial release	—

For pricing, delivery, and ordering information, please contact Maxim Direct at 1-888-629-4642, or visit Maxim Integrated's website at www.maximintegrated.com.

Maxim Integrated cannot assume responsibility for use of any circuitry other than circuitry entirely embodied in a Maxim Integrated product. No circuit patent licenses are implied. Maxim Integrated reserves the right to change the circuitry and specifications without notice at any time.