



Chipsmall Limited consists of a professional team with an average of over 10 year of expertise in the distribution of electronic components. Based in Hongkong, we have already established firm and mutual-benefit business relationships with customers from,Europe,America and south Asia,supplying obsolete and hard-to-find components to meet their specific needs.

With the principle of "Quality Parts,Customers Priority,Honest Operation,and Considerate Service",our business mainly focus on the distribution of electronic components. Line cards we deal with include Microchip,ALPS,ROHM,Xilinx,Pulse,ON,Everlight and Freescale. Main products comprise IC,Modules,Potentiometer,IC Socket,Relay,Connector.Our parts cover such applications as commercial,industrial, and automotives areas.

We are looking forward to setting up business relationship with you and hope to provide you with the best service and solution. Let us make a better world for our industry!



Contact us

Tel: +86-755-8981 8866 Fax: +86-755-8427 6832

Email & Skype: info@chipsmall.com Web: www.chipsmall.com

Address: A1208, Overseas Decoration Building, #122 Zhenhua RD., Futian, Shenzhen, China



General Description

The MAX14483 evaluation kit (EV kit) provides a proven design to evaluate the MAX14483, 6-channel, 3.75kV_{RMS}, SPI digital isolator. The EV kit allows easy access to all six channels through either SMA connectors or test points. On-board LEDs on the ready signals (SAA and SBA) and $\overline{\text{FAULT}}$ output directly indicate the signals' status.

The EV kit should be powered from two independent isolated power supplies with nominal output voltage in range from 1.71V to 5.5V. For evaluating the electrical parameters of the device without any isolation between the two sides, a single power supply can also be used.

The MAX14483EVKIT# comes populated with the MAX14483AAP+ installed in a 20-pin SSOP package with 5.5mm of creepage and clearance.

Features

- Six Unidirectional Channels with Different Channel Direction Configuration and Data Speed (Up to 200Mbps)
- On-Board LEDs Indication of Device Ready for Communication
- SMA Connectors for Easy Connection to External Equipment
- Wide Power Supply Voltage Range from 1.71V to 5.5V
- Guaranteed Up to 3.75kV_{RMS} Isolation for the 20-pin SSOP Package for 60s
- -40°C to +125°C Temperature Range
- Proven PCB Layout
- Fully Assembled and Tested

[Ordering Information](#) appears at end of data sheet.

MAX14483 EV Kit Board Photo

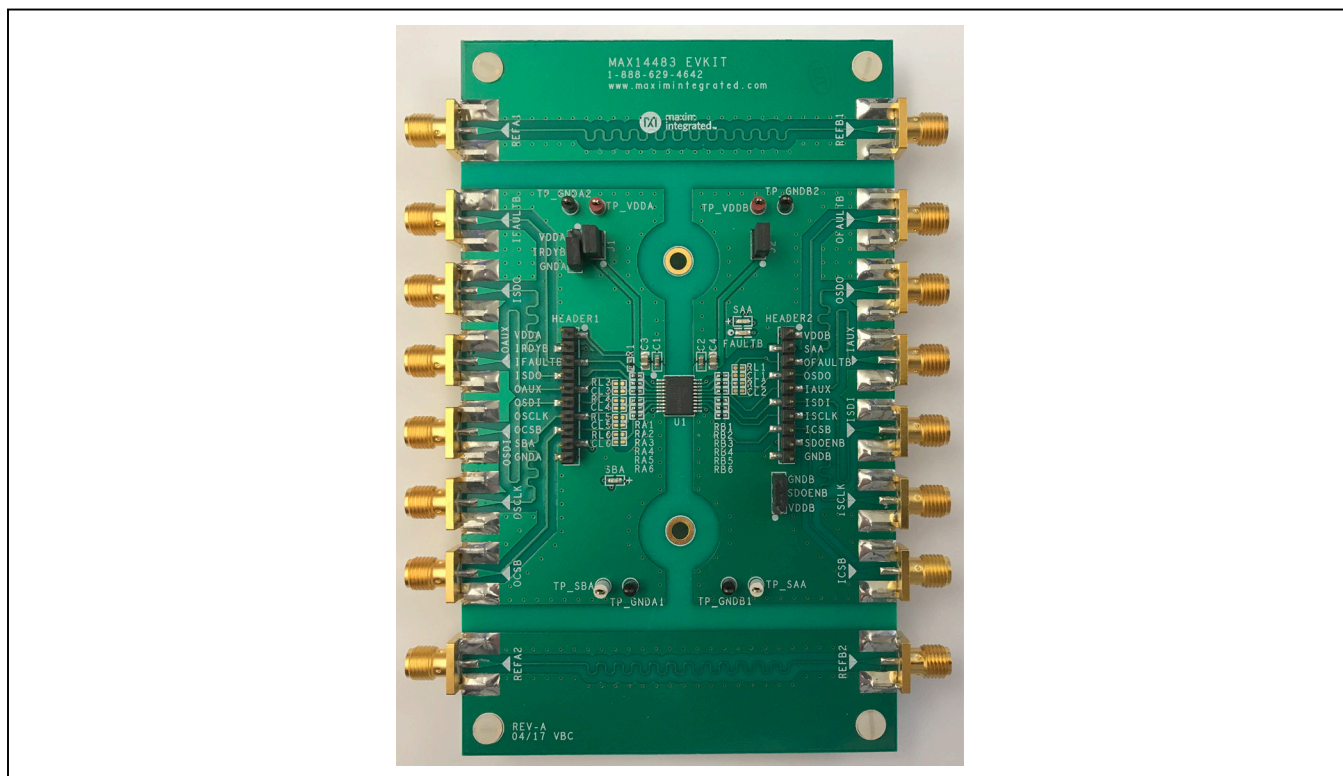

Quick Start

Required Equipment

- MAX14483 EV kit
- Two DC power supplies with output range of 1.71V to 5.5V
- Signal/function generator
- Oscilloscope

Procedure

The MAX14483 EV kit is fully assembled and ready for evaluation. For manual verification follow the steps below to verify board functionality:

- 1) Verify jumper settings. See [Table 1](#) for all shunt positions.
 - J1 and J2 are closed.
 - Jumper IRDYB is in 2-3 position, indicating side A ready for communication.
 - Jumper SDOENB is in 2-3 position, enabling OSDO output.
- 2) Connect one DC power supply between the EV kit's TP_VDDA and TP_GNDA2 test points; connect the other DC power supply between TP_VDDB and TP_GNDB2 test points.
- 3) Set both DC power supply outputs between 1.71V and 5.5V, and then enable the power supply outputs. **Note:** *It is also possible to power the EV kit from a single power supply to test electrical parameters but this invalidates the digital isolation of the IC.*
- 4) Verify that yellow LEDs SAA and SBA are both on, indicating side A and side B are operating normally.
- 5) Connect the signal/function generator to ISDO SMA connector or HEADER1 Pin 4 and observe the isolated signal on the OSDO SMA connector or HEADER2 Pin 4 using an oscilloscope.
- 6) Repeat the step 5 to verify the functionality of $\overline{\text{FAULT}}$, AUX, SDI, SCLK, and $\overline{\text{CS}}$ channels. Note that $\overline{\text{OFAULT}}$ is an open drain output and has a 10k Ω pullup resistor.

Table 1. MAX14483 EV Kit Connectors and Shunt Positions

CONNECTOR	SHUNT POSITION	DESCRIPTION
SIDE A		
HEADER1	1	Test point or input header for V_{DDA}
	2	Test point or input header for side A ready pin $\overline{\text{IRDY}}$; same as IRDYB jumper pin 2
	3	Test point or input header for $\overline{\text{FAULT}}$ channel; same as IFAULTB SMA
	4	Test point or input header for SDO channel; same as ISDO SMA
	5	Test point or output header for AUX channel; same as OAUX SMA
	6	Test point or output header for SDI channel; same as OSDI SMA
	7	Test point or output header for SCLK channel; same as OSCLK SMA
	8	Test point or output header for $\overline{\text{CS}}$ channel; same as OCSB SMA
	9	Test point or output header for side B active pin SBA; same as TP_SBA
	10	Test point or input header for GNDA
IFAULTB	n/a	SMA connector for $\overline{\text{FAULT}}$ channel input IFAULT
ISDO	n/a	SMA connector for SDO channel input ISDO
OAUX	n/a	SMA connector for AUX channel output OAUX
OSDI	n/a	SMA connector for SDI channel output OSDI
OSCLK	n/a	SMA connector for SCLK channel output OSCLK
OCSB	n/a	SMA connector for $\overline{\text{CS}}$ channel output $\overline{\text{OCS}}$
J1	Open	Use current meter to measure current of side A power supply V_{DDA}
	1-2*	Connect power supply to V_{DDA}
IRDYB	1-2	Connect side A ready input $\overline{\text{IRDY}}$ to V_{DDA} ; when $\overline{\text{IRDY}}$ is high, SAA is low and side B outputs are in default state ($\overline{\text{OFAULT}}$ is low and OSDO is low when enabled).
	2-3*	Connect side A ready input $\overline{\text{IRDY}}$ to GNDA; when $\overline{\text{IRDY}}$ is low, and side A power is valid, SAA is high and side B outputs operate normally.

Table 1. MAX14483 EV Kit Connectors and Shunt Positions (continued)

CONNECTOR	SHUNT POSITION	DESCRIPTION
SIDE B		
HEADER2	1	Test point or input header for V_{DDB}
	2	Test point or output header for side A active pin SAA; same as TP_SAA
	3	Test point or output header for $\overline{\text{FAULT}}$ channel; same as OFAULTB SMA
	4	Test point or output header for SDO channel; same as OSDO SMA
	5	Test point or input header for AUX channel; same as IAUX SMA
	6	Test point or input header for SDI channel; same as ISDI SMA
	7	Test point or input header for SCLK channel; same as ISCLK SMA
	8	Test point or input header for $\overline{\text{CS}}$ channel; same as ICSB SMA
	9	Test point or input header for OSDO enable pin $\overline{\text{SDOEN}}$; same as SDOENB jumper pin 2
	10	Test point or input header for GNDB
OFAULTB	n/a	SMA connector for $\overline{\text{FAULT}}$ channel output $\overline{\text{OFAULT}}$
OSDO	n/a	SMA connector for SDO channel output OSDO
IAUX	n/a	SMA connector for AUX channel input IAUX
ISDI	n/a	SMA connector for SDI channel input ISDI
ISCLK	n/a	SMA connector for SCLK channel input ISCLK
ICSB	n/a	SMA connector for $\overline{\text{CS}}$ channel input $\overline{\text{ICS}}$
J2	Open	Use current meter to measure current of side B power supply V_{DDB}
	1-2*	Connect power supply to V_{DDB}
SDOENB	1-2	Connect OSDO enable $\overline{\text{SDOEN}}$ to V_{DDB} ; When both $\overline{\text{SDOEN}}$ and $\overline{\text{ICS}}$ are high, the OSDO output is high-impedance.
	2-3*	Connect OSDO enable $\overline{\text{SDOEN}}$ to GNDB; When $\overline{\text{SDOEN}}$ is low, the OSDO output is enabled.

*Default configuration

Table 2. MAX14483 EV Kit Test Points

TEST POINT	DESCRIPTION
SIDE A	
TP_VDDA	Test point for V_{DDA}
TP_GNDA1	Test point for GNDA
TP_GNDA2	Test point for GNDA
TP_SBA	Test point for side B active SBA
SIDE B	
TP_VDDB	Test point for V_{DDB}
TP_GNDB1	Test point for GNDB
TP_GNDB2	Test point for GNDB
TP_SAA	Test point for side A active SAA

Detailed Description of Hardware

The MAX14483 EV kit allows the user to evaluate the features of the MAX14483 6-channel SPI isolator.

External Power Supplies

Power to the MAX14483 EV kit is derived from two external sources which can both be between +1.71V and +5.5V. Connect one source between the V_{DDA} and GNDA test points, and the other source between the V_{DDB} and GNDB test points.

Each supply can be set independently and can be present over the entire range from 1.71V to 5.5V, regardless of the level or presence of the other supply. The MAX14483 level-shifts the data, transmitting them across the isolation barrier.

Six SMA connectors on each side of the board allow easy connections to signal generator(s) and oscilloscope. A typical test setup is shown in [Figure 1](#).

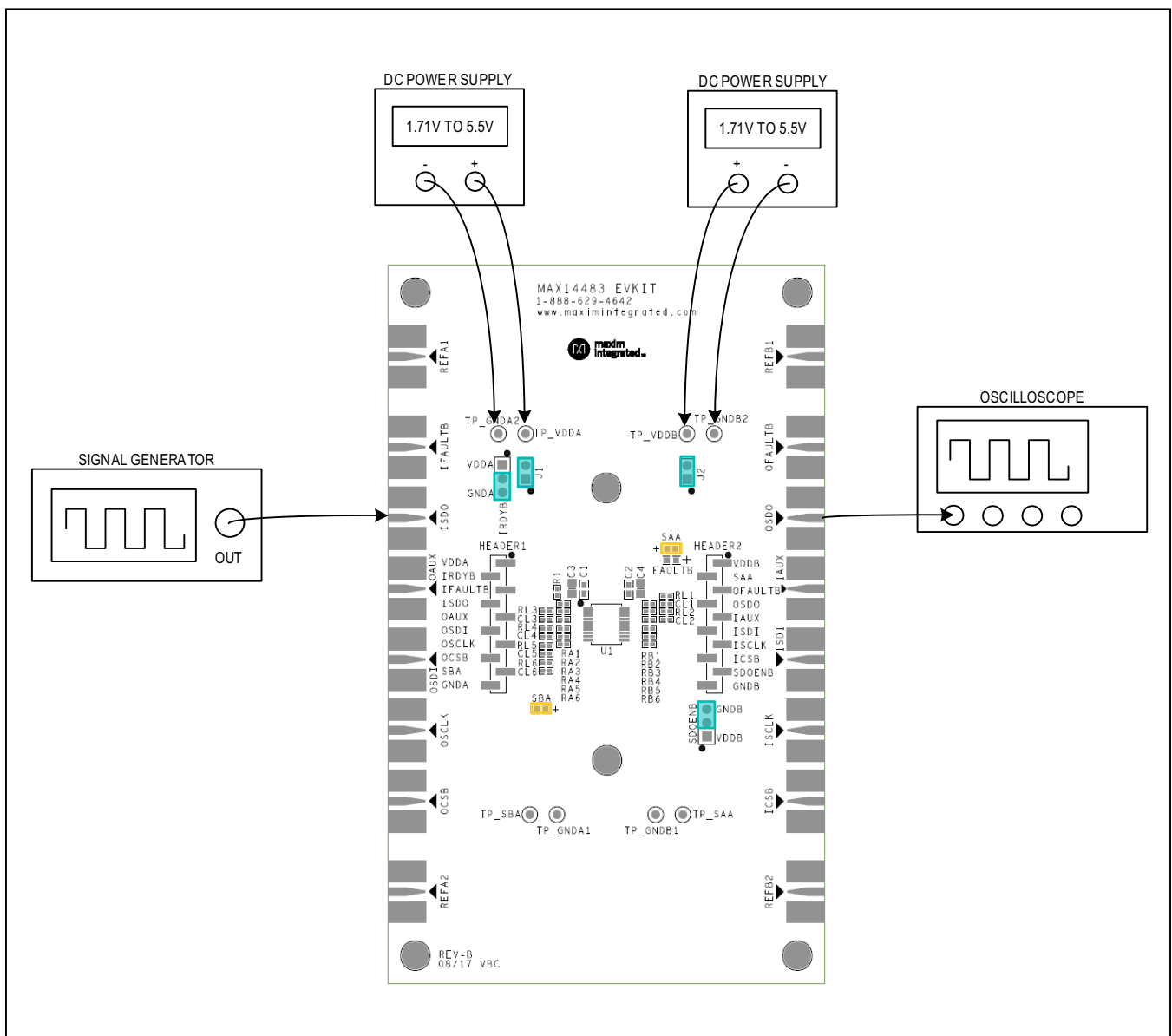

Figure 1. MAX14483 EV Kit Typical Test Setup

Decoupling Capacitors

Each power supply is decoupled with a 10 μ F ceramic capacitor in parallel with a 0.1 μ F ceramic capacitor, which are placed close to the U1 V_{DDA} and V_{DDB} pin.

Shunt Positions

Jumpers J1 and J2 are installed between the external power supplies and U1 power supply pins to allow supply current measurement. Uninstall the J1 and J2 shunts and connect current meters on both side A and side B to measure the MAX14483 supply current.

Jumper IRDYB is provided to configure if side A is ready for communication. When the IRDYB shunt is connected to V_{DDA} ($\overline{\text{IRDY}}$ is high), side A active SAA is low and side B outputs are in their default state ($\overline{\text{OFAULT}}$ is low and OSDO is low when enabled). When the IRDYB shunt is connected to GNDA ($\overline{\text{IRDY}}$ is low), and side A power is valid, SAA is high and side B outputs operate normally.

Jumper SDOENB is provided to enable or disable the SDO channel output (OSDO). When the SDOENB shunt is connected to GNDB, the OSDO output is enabled. When the SDOENB shunt is connected to V_{DDB}, and $\overline{\text{ICS}}$ is high, the OSDO output is high-impedance. Note that when $\overline{\text{ICS}}$ is low, OSDO output is always enabled. See [Table 1](#) for all shunt positions.

Impedance Control

The input and output traces of all six isolation channels have an impedance control of 50 Ω . A 20 Ω series resistor is added to all input and output channels. Along with internal series resistance, it can provide 50 Ω impedance matching with external equipment such as function generator or oscilloscope.

Output Load

Each output has an unpopulated 0603 SMT resistor (RL1-RL6) and an unpopulated 0603 SMT capacitor (CL1-CL6) to GND_ to allow different loads based on customer requirements.

Calibration Channels

Two reference channels (REFA1-REFB1, REFA2-REFB2) are implemented on the EV kit to help calibrate the test setup for timing measurements such as propagation delay. Measure the propagation delay (t_{PD_REF}) using the reference channel first to determine the delay introduced by the test setup. Measure the propagation delay (t_{PD_ISO}) again using one of the MAX14483 data channels. The calibrated isolator delay is $t_{PD_ISO} - t_{PD_REF}$.

Ordering Information

PART	TYPE
MAX14483EVKIT#	EV Kit

#Denotes RoHS compliant.

MAX14483 EV Kit Bill of Materials

ITEM	REF_DES		QTY	MFG PART #	MANUFACTURER	VALUE	DESCRIPTION	COMMENTS
1	C1, C2		2	GCM188R71H104KA12; GCM188R71H104K; CGA3E2X7R1H104K080AA	MURATA; TDK	0.1UF	CAPACITOR; SMT (0603); CERAMIC CHIP; 0.1UF; 50V; TOL=10%; TG=-55 DEGC TO +125 DEGC; TC=X7R; AUTO	
2	C3, C4		2	CL21B106K0QNNN	SAMSUNG ELECTRONICS	10UF	CAPACITOR; SMT (0805); CERAMIC CHIP; 10UF; 16V; TOL=10%; TG=-55 DEGC TO +125 DEGC; TC=X7R	
3	FAULTB		1	HSMH-C190	AVAGO TECHNOLOGIES	HSMH-C190	DIODE; LED; SURFACE MOUNT CHIP LED; RED; SMT (0603); PIV=1.8V; IF=0.02A	
4	HEADER1, HEADER2		2	1-1241150-0	TE CONNECTIVITY	1-1241150-0	CONNECTOR; MALE; SMT; AMPMODU II PIN HEADER; SINGLE ROW; PACKED IN BLISTER; STRAIGHT; 10PINS	
5	IAUX, ICSB, ISDI, ISDO, O AUX, OCSB, OSDI, OSDO, ISCLK, OSCLK, REFA1, REFA2, REFB1, REFB2, IFAULTB, OFAULTB		16	142-0701-851	JOHNSON COMPONENTS	142-0701-851	CONNECTOR; END LAUNCH JACK RECEPTACLE; BOARDMOUNT; STRAIGHT THROUGH; 2PINS;	
6	IRDYB, SDOENB		2	PEC03SAAN	SULLINS	PEC03SAAN	CONNECTOR; MALE; THROUGH HOLE; BREAKAWAY; STRAIGHT; 3PINS	
7	J1, J2		2	PEC02SAAN	SULLINS	PEC02SAAN	CONNECTOR; MALE; THROUGH HOLE; BREAKAWAY; STRAIGHT; 2PINS	
8	Q1, Q2		2	BSS214N	INFINEON	BSS214N	TRAN; OPTIMOS 2 SMALL SIGNAL TRANSISTOR; NCH; PG-SOT23 ; PD-(0.5W); I-(-1.5A); V-(-20V)	
9	Q3		1	PMV65XP	NXP	PMV65XP	TRAN; 20V; SINGLE P-CHANNEL TRENCH MOSFET; PCH; SOT-23; PD-(0.48W); I-(-4.3A); V-(-20V)	
10	R1, R2, R5		3	CRCW0402100KFK; RC0402FR-07100KL	VISHAY DALE; YAGEO PHICOMP	100K	RESISTOR; 0402; 100K; 1%; 100PPM; 0.0625W; THICK FILM	
11	R3, R4, R6		3	CRCW0402470RFKEDHP	VISHAY DRALORIC	470	RESISTOR; 0402; 470 OHM; 1%; 100PPM; 0.125W; THICK FILM	
12	R7		1	ERJ-2RKF1002	PANASONIC	10K	RESISTOR; 0402; 10K OHM; 1%; 100PPM; 0.10W; THICK FILM	
13	RA1-RA6, RB1-RB6		12	CRCW040220R0FK	VISHAY DALE	20	RESISTOR; 0402; 20 OHM; 1%; 100PPM; 0.063W; THICK FILM	
14	SAA, SBA		2	LY L29K-H1K2-26-Z	OSRAM	LY L29K-H1K2-26-Z	DIODE; LED; LY L29K SERIES; SMARTLED; YELLOW; SMT (1608); VF=1.8V; IF=0.02A	
15	SU1-SU4		4	STC02SYAN	SULLINS ELECTRONICS CORP.	STC02SYAN	TEST POINT; JUMPER; STR; TOTAL LENGTH=0.256IN; BLACK; INSULATION=PBT CONTACT=PHOSPHOR BRONZE; COPPER PLATED TIN OVERALL	
16	TP_GNDA1, TP_GNDA2, TP_GNDB1, TP_GNDB2		4	5001	KEystone	N/A	TEST POINT; PIN DIA=0.1IN; TOTAL LENGTH=0.3IN; BOARD HOLE=0.04IN; BLACK; PHOSPHOR BRONZE WIRE SILVER PLATE FINISH;	
17	TP_SAA, TP_SBA		2	5002	KEystone	N/A	TEST POINT; PIN DIA=0.1IN; TOTAL LENGTH=0.3IN; BOARD HOLE=0.04IN; WHITE; PHOSPHOR BRONZE WIRE SILVER;	
18	TP_VDDA, TP_Vddb		2	5000	KEystone	N/A	TEST POINT; PIN DIA=0.1IN; TOTAL LENGTH=0.3IN; BOARD HOLE=0.04IN; RED; PHOSPHOR BRONZE WIRE SILVER PLATE FINISH;	
19	U1		1	MAX14483AAP+	MAXIM	MAX14483AAP+	EVKIT PART - IC; MAX14483AAP+; 8-CHANNEL; LOW POWER; 3.75KV RMS; SPI DIGITAL ISOLATOR; PACKAGE OUTLINE DRAWING: 21-0056; LAND PATTERN: 90-0094	
20	PCB		1	MAX14483	MAXIM	PCB	PCB:MAX14483	-
21	MTH1-MTH6	DNI	6	1902B	GENERIC PART	?	STANDOFF; FEMALE-THREADED; HEX; 4-40IN; 3/8IN; NYLON	
22	MTH1-MTH6	DNI	6	P440.375	GENERIC PART	?	MACHINE SCREW; SLOTTED; PAN; 4-40IN; 3/8IN; NYLON	
23	MTH1-MTH6	DNI	6	EVKIT_STANDOFF_4-40_3/8	?	EVKIT_STANDOFF_4-40_3/8	KIT; ASSY-STANDOFF 3/8IN; 1PC. STANDOFF/FEM/HEX/4-40IN/(3/8IN)/NYLON; 1PC. SCREW/SLOT/PAN/4-40IN/(3/8IN)/NYLON	
24	RL1-RL6	DNP	0	N/A	N/A	OPEN	PACKAGE OUTLINE 0402 RESISTOR	
25	CL1-CL6	DNP	0	N/A	N/A	OPEN	PACKAGE OUTLINE 0402 NON-POLAR CAPACITOR	
TOTAL			83					

MAX14483 EV Kit Schematic

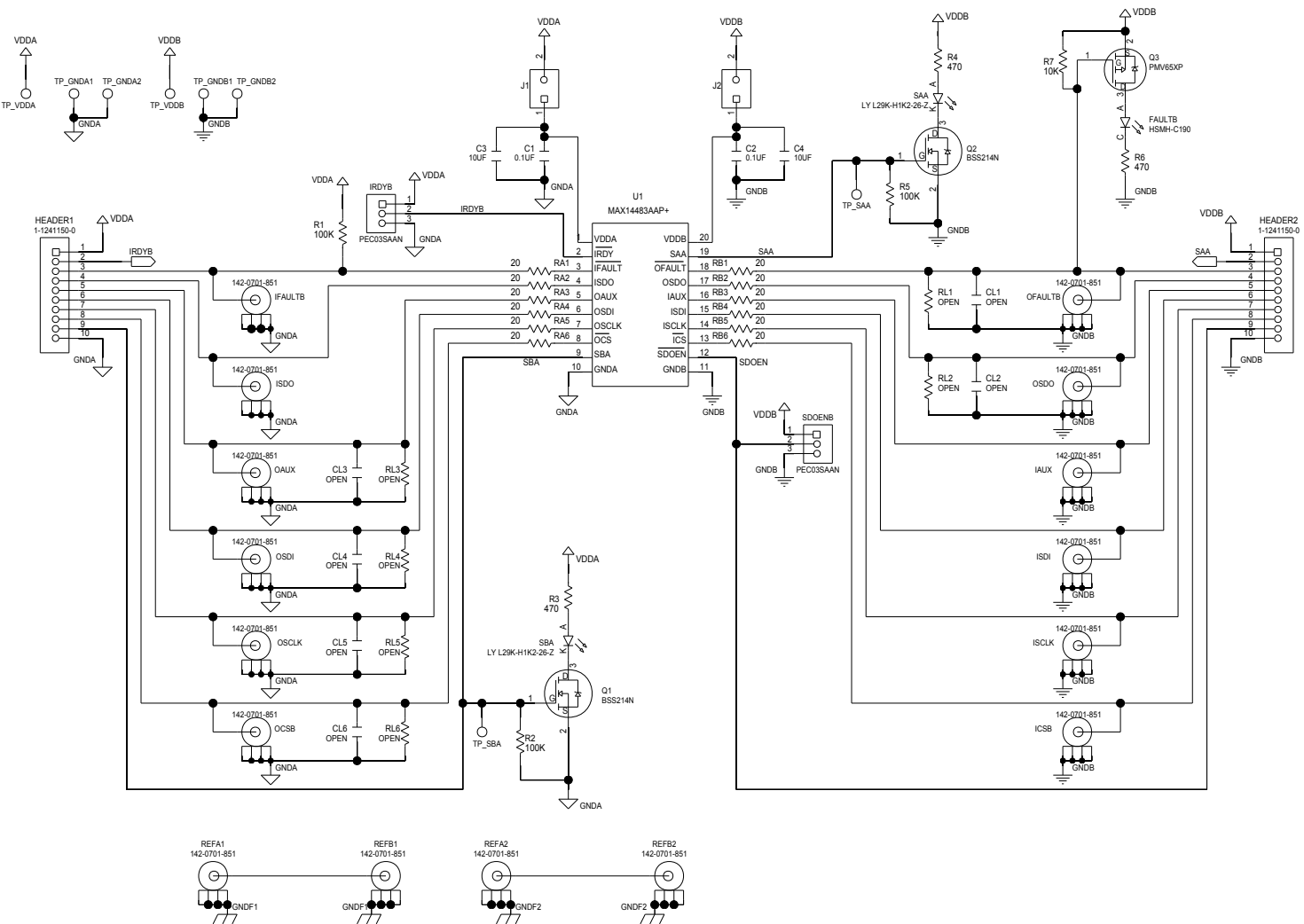

MAX14483 EV Kit PCB Layout Diagrams

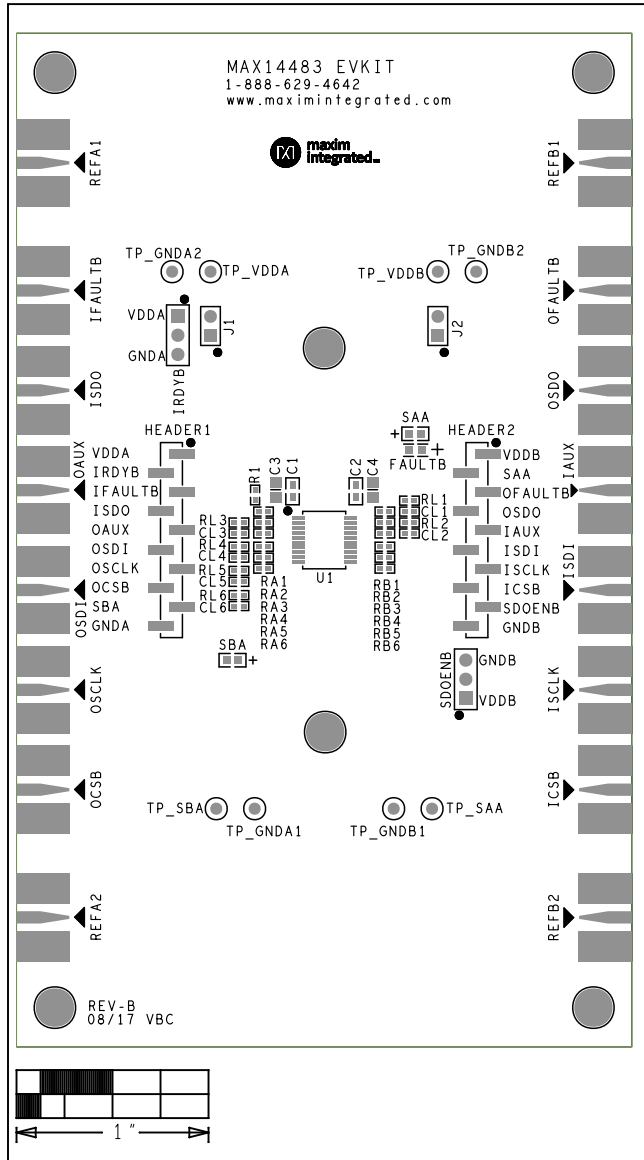

MAX14483 EV Kit—Top Silkscreen

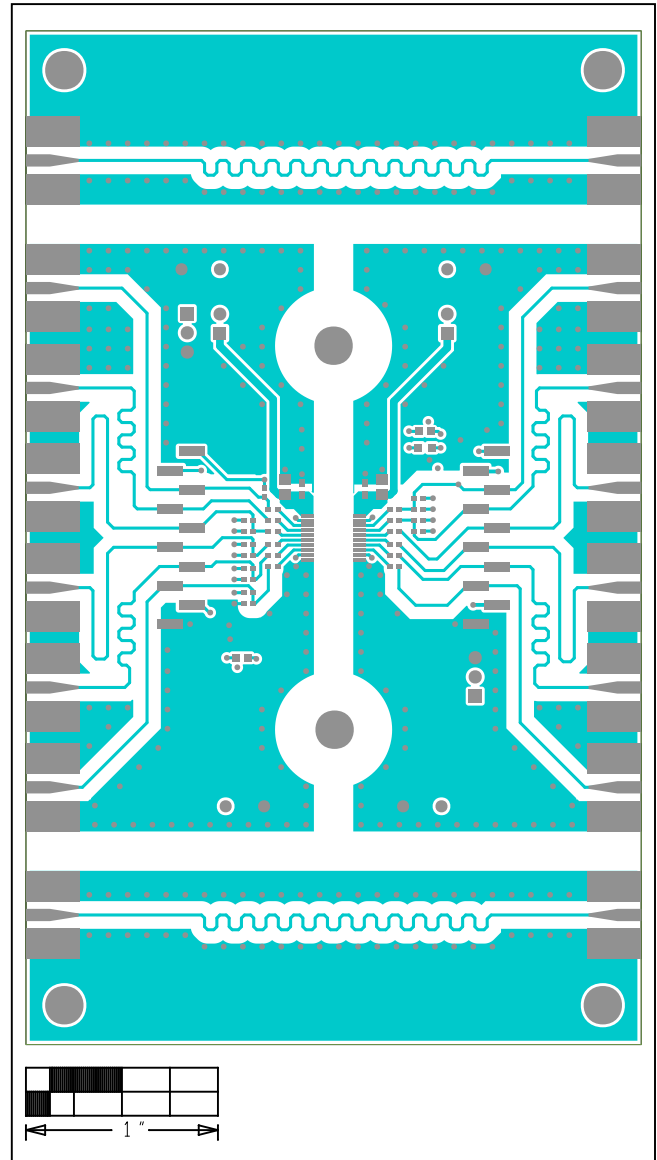

MAX14483 EV Kit—Top

MAX14483 EV Kit PCB Layout Diagrams (continued)

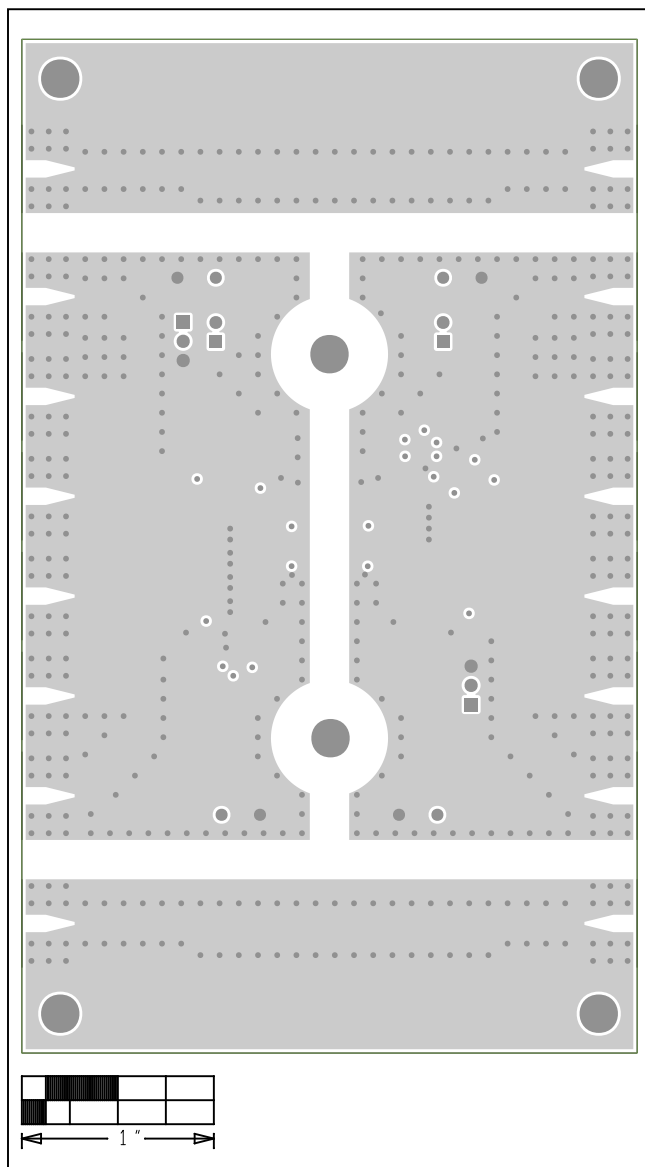

MAX14483 EV Kit—L2 GND

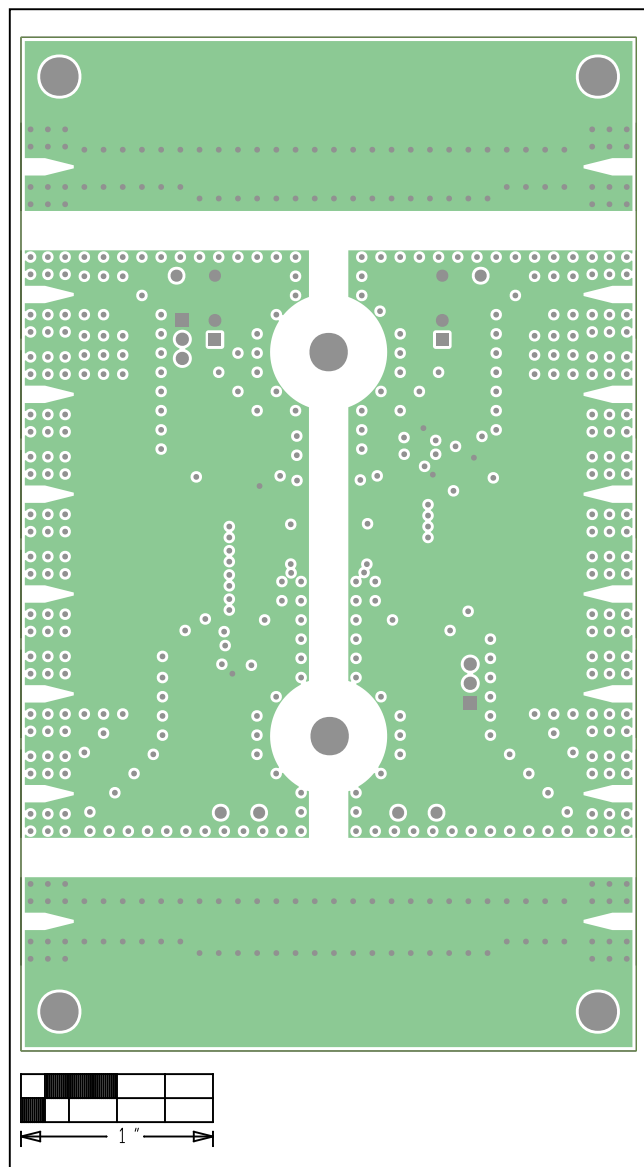

MAX14483 EV Kit—L3 PWR

MAX14483 EV Kit PCB Layout Diagrams (continued)

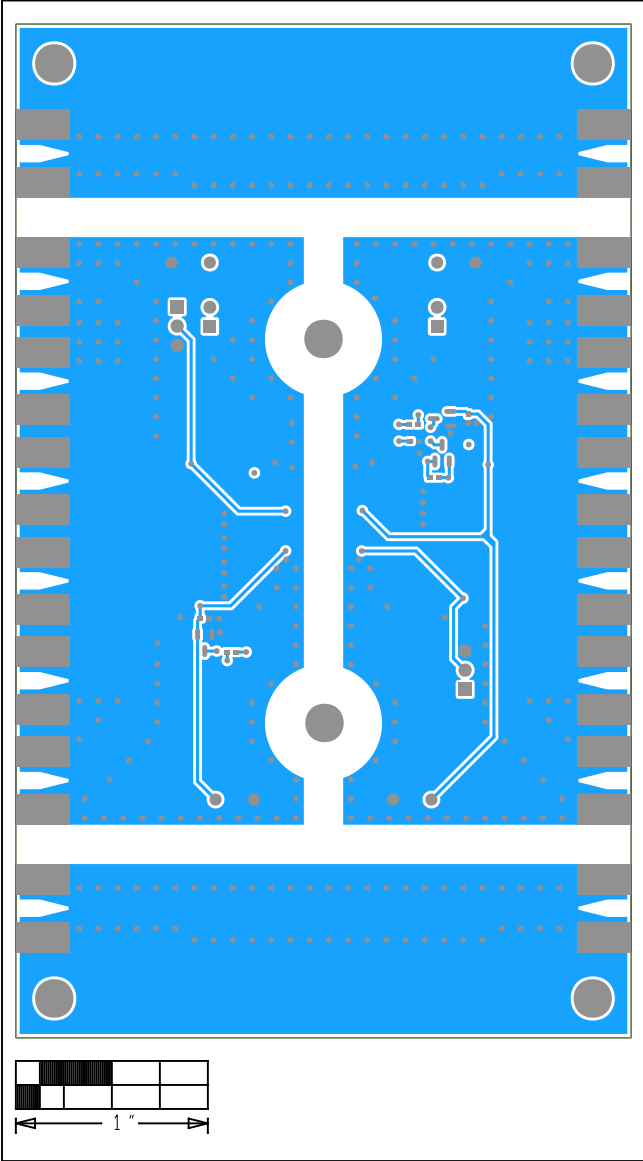

MAX14483 EV Kit—Bottom

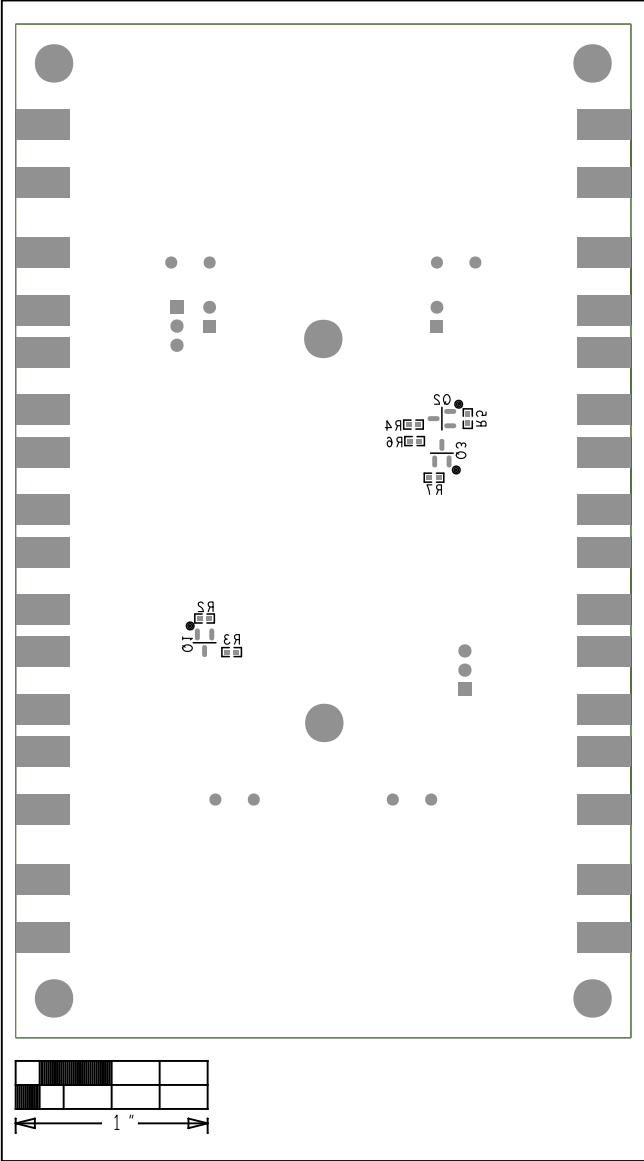

MAX14483 EV Kit—Bottom Silkscreen

Revision History

REVISION NUMBER	REVISION DATE	DESCRIPTION	PAGES CHANGED
0	1/18	Initial release	—

For pricing, delivery, and ordering information, please contact Maxim Direct at 1-888-629-4642, or visit Maxim Integrated's website at www.maximintegrated.com.

Maxim Integrated cannot assume responsibility for use of any circuitry other than circuitry entirely embodied in a Maxim Integrated product. No circuit patent licenses are implied. Maxim Integrated reserves the right to change the circuitry and specifications without notice at any time.