



Chipsmall Limited consists of a professional team with an average of over 10 year of expertise in the distribution of electronic components. Based in Hongkong, we have already established firm and mutual-benefit business relationships with customers from,Europe,America and south Asia,supplying obsolete and hard-to-find components to meet their specific needs.

With the principle of “Quality Parts,Customers Priority,Honest Operation,and Considerate Service”,our business mainly focus on the distribution of electronic components. Line cards we deal with include Microchip,ALPS,ROHM,Xilinx,Pulse,ON,Everlight and Freescale. Main products comprise IC,Modules,Potentiometer,IC Socket,Relay,Connector.Our parts cover such applications as commercial,industrial, and automotives areas.

We are looking forward to setting up business relationship with you and hope to provide you with the best service and solution. Let us make a better world for our industry!



Contact us

Tel: +86-755-8981 8866 Fax: +86-755-8427 6832

Email & Skype: info@chipsmall.com Web: www.chipsmall.com

Address: A1208, Overseas Decoration Building, #122 Zhenhua RD., Futian, Shenzhen, China



Low-Power, Low-Noise Multichannel Sensor Signal Processor

General Description

The MAX1464 is a highly integrated, low-power, low-noise multichannel sensor signal processor optimized for industrial, automotive, and process-control applications such as pressure sensing and compensation, RTD and thermocouple linearization, weight sensing and classification, and remote process monitoring with limit indication.

The MAX1464 accepts sensors with either single-ended or differential outputs. The MAX1464 accommodates sensor output sensitivities from 1mV/V to 1V/V. The MAX1464 provides amplification, calibration, signal linearization, and temperature compensation that enable an overall performance approaching the inherent repeatability of the sensor without requiring any external trim components.

Two 16-bit voltage-output DACs and two 12-bit PWMs can be used to indicate each of the temperature-compensated sensor signals independently, as a sum or difference signal, or user-defined relationship between each signal and temperature. Uncommitted op amps are available to buffer the DAC outputs, drive heavier external loads, or provide additional gain and filtering.

The MAX1464 incorporates a 16-bit CPU, user-programmable 4kB of FLASH program memory, 128 bytes of FLASH user information, one 16-bit ADC, two 16-bit DACs, two 12-bit PWM digital outputs, four rail-to-rail op amps, one SPI™-compatible interface, two GPIOs, and one on-chip temperature sensor.

The MAX1464 operates from a single 5.0V (typ) supply and is packaged for automotive, industrial, and commercial temperature ranges in a 28-pin SSOP package.

Applications

- Pressure Sensor Signal Conditioning
- Weight Measurement Systems
- Thermocouple and RTD Linearization
- Transducers and Transmitters
- Process Indicators
- Calibrators and Controllers
- GMR and MR Magnetic Direction Sensors

Functional Diagram and Detailed Block Diagram appear at end of data sheet.

SPI is a trademark of Motorola, Inc.

Features

- ◆ Programmable Amplification, Calibration, Linearization, and Temperature Compensation
- ◆ Two Differential or Four Single-Ended ADC Input Channels
- ◆ Accommodates Sensor Output Sensitivities from 1mV/V to 1V/V
- ◆ Two DAC/PWM Output Signal Channels
- ◆ Supports 4–20mA Current Loop Applications
- ◆ 4kB of FLASH Memory for Code and Coefficients
- ◆ 128 Bytes of FLASH Memory for User Information
- ◆ Integrated Temperature Sensing
- ◆ Flexible Dual Op-Amp Block
- ◆ Programmable Sensor Input Gain and Offset
- ◆ Programmable Sensor Sampling Rate and Resolution
- ◆ No External Trim Components Required

Ordering Information

PART	TEMP RANGE	PIN-PACKAGE
MAX1464CAI	0°C to +70°C	28 SSOP
MAX1464C/W*	0°C to +70°C	Die
MAX1464EAI	-40°C to +85°C	28 SSOP
MAX1464AAI	-40°C to +125°C	28 SSOP

*Dice are tested at $T_A = +25^\circ\text{C}$, DC parameters only.

Pin Configuration

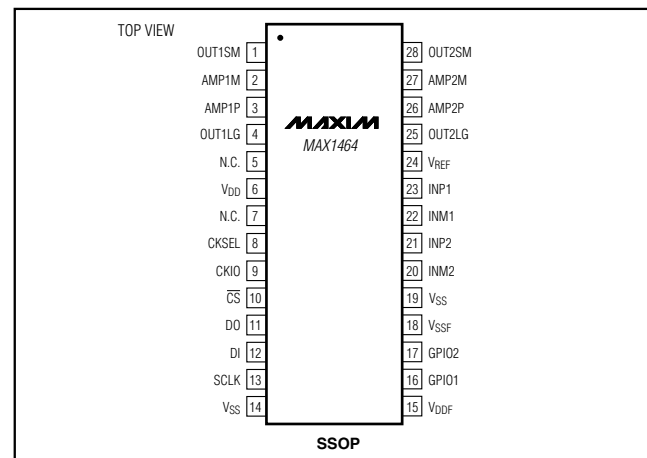

Low-Power, Low-Noise Multichannel Sensor Signal Processor

ABSOLUTE MAXIMUM RATINGS

V _{DD} to V _{SS}	-0.3V to +6.0V
V _{DDF} to V _{SS}	-0.3V to +6.0V
V _{SSF} to V _{SS}	-0.3V to +0.3V
All Other Pins to V _{SS}	-0.3V to (V _{DD} + 0.3V)
Continuous Power Dissipation (T _A = +70°C)	
28-Pin SSOP (derate 9.1mW/°C above +70°C).....	727mW

Operating Temperature Ranges

MAX1464CAI.....	0°C to +70°C
MAX1464C/W.....	0°C to +70°C
MAX1464EAI.....	-40°C to +85°C
MAX1464AAI.....	-40°C to +125°C
Junction Temperature.....	+150°C
Storage Temperature Range.....	-65°C to +150°C
Lead Temperature (soldering, 10s).....	+300°C

Stresses beyond those listed under "Absolute Maximum Ratings" may cause permanent damage to the device. These are stress ratings only, and functional operation of the device at these or any other conditions beyond those indicated in the operational sections of the specifications is not implied. Exposure to absolute maximum rating conditions for extended periods may affect device reliability.

ELECTRICAL CHARACTERISTICS

(V_{DDF} = V_{DD} = 4.5V to 5.5V, V_{SSF} = V_{SS} = 0V, f_{CLK} = 4.0MHz, T_A = T_{MIN} to T_{MAX}. Typical values are at V_{DDF} = V_{DD} = 5.0V, V_{SSF} = V_{SS} = 0V, T_A = +25°C, unless otherwise noted.) (Note 1)

PARAMETER	SYMBOL	CONDITIONS	MIN	TYP	MAX	UNITS		
SUPPLY								
Supply Voltage	V _{DD}	V _{SS} = V _{SSF} = 0V	4.5	5.0	5.5	V		
FLASH Supply Voltage	V _{DDF}	V _{SS} = V _{SSF} = 0V	4.5	5.0	5.5	V		
Base Operating Current	I _{BO}	CPU stopped (Note 2)	575	720	890	μA		
CPU Current	I _{CPU}	All modules off, CPU = on, additive to I _{BO} , I _{CPU} = I _{DD} + I _{DDF} (Note 3)	540	840	1240	μA		
ADC Current (Note 3)	I _{ADC}	All modules off, ADC = on, ADC clk = 1MHz, additive to I _{BO} ; the CPU and ADC are not on at the same time	690	1040	1394	μA		
		All modules off, ADC = on, ADC clk = 7kHz, additive to I _{BO} ; the CPU and ADC are not on at the same time	465	765	1060			
DAC Current	I _{DACn}	All modules off, DAC = on, additive to I _{BO} (n = 1 or 2) (Note 4)	425	550	730	μA		
Large Op-Amp Current	I _{OPLGn}	All modules off, CPU stopped, large op amp = on (n = 1 or 2)	430	673	1020	μA		
Small Op-Amp Current	I _{OPSMn}	All modules off, CPU stopped, small op amp = on (n = 1 or 2)	110	190	265	μA		
POWER-ON RESET								
V _{DDF} POR Threshold		V _{DD} > V _{DDF}	3.6	4.0	4.3	V		
V _{DDF} POR Hysteresis				-0.85		V		
ANALOG INPUT								
Differential Input Impedance (INP1 to INM1 and INP2 to INM2)	R _{DIN}	PGA[4:0] = 00000, CLK[2:0] = 000		430		kΩ		
		PGA[4:0] = 01010, CLK[2:0] = 000		55				
		PGA[4:0] = 11111, CLK[2:0] = 000		36				
				PGA[4:0] = 00000, CLK[2:0] = 011		3.4		MΩ
				PGA[4:0] = 01010, CLK[2:0] = 011		440		kΩ
				PGA[4:0] = 11111, CLK[2:0] = 011		288		
				PGA[4:0] = 00000, CLK[2:0] = 110		27		MΩ
				PGA[4:0] = 01010, CLK[2:0] = 110		3.5		
		PGA[4:0] = 11111, CLK[2:0] = 110		2.3				

Low-Power, Low-Noise Multichannel Sensor Signal Processor

MAX1464

ELECTRICAL CHARACTERISTICS (continued)

(V_{DDF} = V_{DD} = 4.5V to 5.5V, V_{SSF} = V_{SS} = 0V, f_{CLK} = 4.0MHz, T_A = T_{MIN} to T_{MAX}. Typical values are at V_{DDF} = V_{DD} = 5.0V, V_{SSF} = V_{SS} = 0V, T_A = +25°C, unless otherwise noted.) (Note 1)

PARAMETER	SYMBOL	CONDITIONS	MIN	TYP	MAX	UNITS		
Single-Sided Input Impedance (INP1 to V _{SS} , INM1 to V _{SS} , INP2 to V _{SS} , INM2 to V _{SS})	R _{SIN}	PGA[4:0] = 00000, CLK[2:0] = 000		430		kΩ		
		PGA[4:0] = 01010, CLK[2:0] = 000		55				
		PGA[4:0] = 11111, CLK[2:0] = 000		36				
				PGA[4:0] = 00000, CLK[2:0] = 011		3.4		MΩ
				PGA[4:0] = 01010, CLK[2:0] = 011		440		kΩ
				PGA[4:0] = 11111, CLK[2:0] = 011		288		
				PGA[4:0] = 00000, CLK[2:0] = 110		27		MΩ
				PGA[4:0] = 01010, CLK[2:0] = 110		3.5		
				PGA[4:0] = 11111, CLK[2:0] = 110		2.3		
Common-Mode Rejection Ratio	CMRR	Common-mode voltage V _{CM} = V _{SS} to V _{DD}		0.008		%FS		
Differential Signal-Gain Range		Selectable in 17 steps (Note 5)		0.99 to 244		V/V		
Differential Signal Gain	AV _{DIFF}	PGA[4:0] = 00000	0.95	0.99	1.05	V/V		
		PGA[4:0] = 00001	7.3	7.7	8.2			
		PGA[4:0] = 01010	71	77	82			
		PGA[4:0] = 10100	137	153	168			
		PGA[4:0] = 11110	203	244	283			
Gain-Error Temperature Coefficient	GETC _{ADC}	PGA[4:0] = 00000		-8		ppm/°C		
COARSE-OFFSET DAC								
Resolution		3-bit plus sign		4		Bits		
Effective Offset Adjustment at the ADC Input	OA _{ADC}	REF = V _{DD} , CO[3:0] = 0111	PGA[4:0] = 00000 to 01000	137	147	157	% of ADC Ref	
			PGA[4:0] = 01010 to 10000	273	291	308		
			PGA[4:0] = 10100 to 11110	525	578	630		
		REF = V _{DD} , CO[3:0] = 0011	PGA[4:0] = 00000 to 01000	57	64	69		
			PGA[4:0] = 01010 to 10000	113	126	136		
			PGA[4:0] = 10100 to 11110	228	251	276		
		REF = V _{DD} , CO[3:0] = 0000	PGA[4:0] = 00000 to 01000	-3	-1	+1		
			PGA[4:0] = 01010 to 10000	-7	-2.4	+2		
			PGA[4:0] = 10100 to 11110	-11	-4	+3		

Low-Power, Low-Noise Multichannel Sensor Signal Processor

ELECTRICAL CHARACTERISTICS (continued)

($V_{DDF} = V_{DD} = 4.5V$ to $5.5V$, $V_{SSF} = V_{SS} = 0V$, $f_{CLK} = 4.0MHz$, $T_A = T_{MIN}$ to T_{MAX} . Typical values are at $V_{DDF} = V_{DD} = 5.0V$, $V_{SSF} = V_{SS} = 0V$, $T_A = +25^\circ C$, unless otherwise noted.) (Note 1)

PARAMETER	SYMBOL	CONDITIONS	MIN	TYP	MAX	UNITS	
Effective Offset Adjustment at the ADC Input	OA _{ADC}	REF = V _{DD} , CO[3:0] = 1000	PGA[4:0] = 00000 to 01000	-15	-10	-4	% of ADC Ref
			PGA[4:0] = 01010 to 10000	-29	-19	-10	
			PGA[4:0] = 10100 to 11110	-56	-38	-20	
		REF = V _{DD} , CO[3:0] = 1011	PGA[4:0] = 00000 to 01000	-79	-73	-66	
			PGA[4:0] = 01010 to 10000	-155	-145	-135	
			PGA[4:0] = 10100 to 11110	-317	-287	-257	
		REF = V _{DD} , CO[3:0] = 1111	PGA[4:0] = 00000 to 01000	-162	-156	-150	
			PGA[4:0] = 01010 to 10000	-327	-309	-293	
			PGA[4:0] = 10100 to 11110	-675	-614	-555	
SMALL OP AMP							
Input Offset Voltage	V _{OS_SM}			0	±15	mV	
Input Bias Current	I _{B_SM}			±1		nA	
DC Gain	A _{VOL_SM}	OUT _{nSM} = 0.5V to 4.5V (n = 1 or 2), R _{LOAD} = ∞		100		dB	
Gain Bandwidth Product	GBW _{SM}	A _{VOL_SM} = +1V/V		2.7		MHz	
Slew Rate	SR _{SM}	A _{VOL_SM} = +1V/V		2.2		V/μs	
Common-Mode Input Range	CMR _{SM}		V _{SS} + 0.02		V _{DD} - 0.02	V	
Common-Mode Rejection Ratio	CMRR _{SM}	V _{CM_OPAMP} = V _{SS} to V _{DD}		70		dB	
Power-Supply Rejection Ratio	PSRR _{SM}	At DC		70		dB	
Input-Referred Noise Voltage	V _{N_SM}	0.1Hz to 1kHz		8.5		μV _{RMS}	
		0.1Hz to 1MHz		100			
Output High Voltage	V _{OH_SM}	R _{LOAD} = ∞		V _{DD} - 0.1		V	
		R _{LOAD} = 4.7kΩ to V _{SS}		V _{DD} - 0.15			
Output Low Voltage	V _{OL_SM}	R _{LOAD} = ∞			0.1	V	
		R _{LOAD} = 4.7kΩ to V _{DD}			0.15		
Output Source Current	I _{SRC_SM}	V _{OUTnSM} = V _{OH_SM} , R _{LOAD} = 4.7kΩ to V _{SS}			-1.04	mA	
Output Sink Current	I _{SNK_SM}	V _{OUTnSM} = V _{OL_SM} , R _{LOAD} = 4.7kΩ to V _{DD}			1.04	mA	
Maximum Output Load Capacitance	C _{L_SM}	R _{LOAD} = ∞, phase margin > 55°		120		pF	

Low-Power, Low-Noise Multichannel Sensor Signal Processor

MAX1464

ELECTRICAL CHARACTERISTICS (continued)

($V_{DDF} = V_{DD} = 4.5V$ to $5.5V$, $V_{SSF} = V_{SS} = 0V$, $f_{CLK} = 4.0MHz$, $T_A = T_{MIN}$ to T_{MAX} . Typical values are at $V_{DDF} = V_{DD} = 5.0V$, $V_{SSF} = V_{SS} = 0V$, $T_A = +25^{\circ}C$, unless otherwise noted.) (Note 1)

PARAMETER	SYMBOL	CONDITIONS	MIN	TYP	MAX	UNITS
LARGE OP AMP						
Input Offset Voltage	V_{OS_LG}			0	± 6	mV
Input Bias Current	I_{B_LG}			± 225		nA
DC Gain	A_{VOL_LG}	$OUTnLG = 0.5V$ to $4.5V$ ($n = 1$ or 2), $R_{LOAD} = \infty$		100		dB
Gain Bandwidth Product	GBW_LG	$A_{VOL_LG} = +1V/V$		4.0		MHz
Slew Rate	SR_LG	$A_{VOL_LG} = +1V/V$		3.2		V/ μs
Common-Mode Input Range	CMR_LG		$V_{SS} + 0.02$		$V_{DD} - 0.02$	V
Common-Mode Rejection Ratio	$CMRR_LG$	$V_{CM\ OPAMP} = V_{SS}$ to V_{DD}		70		dB
Power-Supply Rejection Ratio	$PSRR_LG$	At DC		70		dB
Input-Referred Noise Voltage	V_{N_LG}	0.1Hz to 1kHz		19		μV_{RMS}
		0.1Hz to 1MHz		160		
Output-Voltage High	V_{OH_LG}	$R_{LOAD} = \infty$		$V_{DD} - 0.1$		V
		$R_{LOAD} = 1k\Omega$ to V_{SS}		$V_{DD} - 0.125$		
Output-Voltage Low	V_{OL_LG}	$R_{LOAD} = \infty$			0.03	V
		$R_{LOAD} = 1k\Omega$ to V_{DD}			0.13	
Output Source Current	I_{SRC_LG}	$V_{OUTnLG} = V_{OH_LG}$, $R_{LOAD} = 1k\Omega$ to V_{SS}			-4.9	mA
Output Sink Current	I_{SNK_LG}	$V_{OUTnLG} = V_{OL_LG}$, $R_{LOAD} = 1k\Omega$ to V_{DD}			4.9	mA
Maximum Output Load Capacitance	C_{L_LG}	$R_{LOAD} = \infty$, phase margin $> 55^{\circ}$		200		pF
OP-AMP SWITCH						
Analog Signal Range	V_{SW}		V_{SS}		V_{DD}	V
On-Resistance	R_{ON}			5		$k\Omega$
Off-Isolation	V_{ISO}			80		dB
DIGITAL-TO-ANALOG CONVERTER						
Resolution	RES_{DAC}			16		Bits
Integral Nonlinearity	INL_{DAC}			3		Bits
Differential Nonlinearity	DNL_{DAC}			± 1		Bits
Offset Error	$V_{DAC\ OS}$	DAC ref = V_{DD} , DAC data = 0000h	$V_{DD} / 2 - 0.06$		$V_{DD} / 2 + 0.06$	V
Bit Weight	BW_{DAC}	DAC ref = 5VDC		91.55		$\mu V/LSB$
Power-Supply Rejection	PSR_{DAC}	At DC, DAC ref = V_{REF}		0.02		%FS
Output Noise	ON_{DAC}	DAC buffer is the small op amp		± 3		LSB
Output Settling Time	ST_{DAC}	To 0.1% of final value		250		μs
PULSE-WIDTH MODULATOR						
Resolution	RES_{PWM}	(Note 6)		12		Bits
Period	$PPWM$	$f_{CLK} = 4.0MHz$		8.192		ms

Low-Power, Low-Noise Multichannel Sensor Signal Processor

ELECTRICAL CHARACTERISTICS (continued)

($V_{DDF} = V_{DD} = 4.5V$ to $5.5V$, $V_{SSF} = V_{SS} = 0V$, $f_{CLK} = 4.0MHz$, $T_A = T_{MIN}$ to T_{MAX} . Typical values are at $V_{DDF} = V_{DD} = 5.0V$, $V_{SSF} = V_{SS} = 0V$, $T_A = +25^{\circ}C$, unless otherwise noted.) (Note 1)

PARAMETER	SYMBOL	CONDITIONS	MIN	TYP	MAX	UNITS
Bit Weight	BWPWM			2		$\mu s/LSB$
Offset Error	VPWM_LOS	PWM data = 0000h		± 1		μs
Gain Error	GE_PWM	(Note 7)		± 0.025		%
Output Jitter	OJPWM			1/4		LSB
EXTERNAL REFERENCE INPUT						
Reference Input Voltage Range	VREF		2.25	2.5	2.75	V
Reference Input Resistance	RREF	$V_{REF} = 2.5V$, ADC = ON, DACs = ON	100			$k\Omega$
INTERNAL VOLTAGE REFERENCE						
Internal Voltage Reference	VIR	(Note 8)	4.5	4.92	5.35	V
Temperature Coefficient	TCIR			± 110		ppm/ $^{\circ}C$
TEMPERATURE SENSOR						
Sensitivity	SensTS	PGA[4:0] = 00001, CO[3:0] = 0110		+2		mV/ $^{\circ}C$
				+95		LSB/ $^{\circ}C$
Nonlinearity Error	INLTS			± 0.5		%FS
Hysteresis	HistTS			± 0.1		%FS
ANALOG-TO-DIGITAL CONVERTER						
Resolution	RES_ADC			16		Bits
Integral Nonlinearity	INL_ADC			2		Bits
Differential Nonlinearity	DNL_ADC			± 1		LSB
ADC Offset Error	VADC_OS	PGA[4:0] = 00000 (0.99), CO[3:0] = 0000 (Note 9)		4		%FS
Channel-to-Channel Offset Error Matching	ΔV_{ADC_OS}			± 1		LSB
ADC Offset-Supply Rejection	OSR_ADC	At DC, ADC ref = $V_{REF} = 5V$		0.3		%FS
ADC Gain-Supply Rejection	GSR_ADC	At DC, ADC ref = $V_{REF} = 5V$		0.005		%FS
Offset Temperature Coefficient		$T_A = -40^{\circ}C$ to $+125^{\circ}C$		0.03		%FS
Ratiometricity		PGA[4:0] = 00000 to 01000		0.02		%FS

Low-Power, Low-Noise Multichannel Sensor Signal Processor

MAX1464

ELECTRICAL CHARACTERISTICS (continued)

(V_{DDF} = V_{DD} = 4.5V to 5.5V, V_{SSF} = V_{SS} = 0V, f_{CLK} = 4.0MHz, T_A = T_{MIN} to T_{MAX}. Typical values are at V_{DDF} = V_{DD} = 5.0V, V_{SSF} = V_{SS} = 0V, T_A = +25°C, unless otherwise noted.) (Note 1)

PARAMETER	SYMBOL	CONDITIONS	MIN	TYP	MAX	UNITS
DIGITAL INPUTS (GPIO1, GPIO2, SCLK, DI, CKSEL, CKIO, \overline{CS})						
Input High Threshold Voltage	V _{IH}		0.8 x V _{DD}			V
Input Low Threshold Voltage	V _{IL}				0.2 x V _{DD}	V
Input Hysteresis	V _{IHYS}			0.2		V
Input Leakage Current	I _{IN}	CKSEL, \overline{CS} = V _{SS}		38	-90	μA
		GPIO1, GPIO2, SCLK, DI, CKIO = V _{DD}		38	+90	
Input Capacitance	C _{IN}			5		pF
DIGITAL OUTPUTS (GPIO1, GPIO2, DO, CKIO)						
Output-Voltage High	V _{OH}	R _{LOAD} = ∞	GPIO1, GPIO2, DO	V _{DD} - 0.1		V
			CKIO (Note 10)	4.9		
		R _{LOAD} = 2kΩ to V _{SS}	GPIO1, GPIO2, DO	V _{DD} - 0.15		
			CKIO (Note 10)	4.6		
Output-Voltage Low	V _{OL}	R _{LOAD} = ∞	GPIO1, GPIO2, DO	0.05		V
			CKIO (Note 10)	0.1		
		R _{LOAD} = 2kΩ to V _{DD}	GPIO1, GPIO2, DO	0.2		
			CKIO (Note 10)	0.4		
FLASH MEMORY						
Maximum Erase Cycles		(Notes 11, 12)	10k			Cycles
Minimum Erase Time	t _{ERASE}	(Notes 11, 12)	4.2			ms
Minimum Write Time	t _{WRITE}	(Notes 11, 12)	80			μs
FLASH Programming Current	I _{DDFP}	Writing to the FLASH or erasing the FLASH (Note 13)	30			mA

Note 1: Current into a pin is defined as positive. Current out of a pin is defined as negative. All voltages are referenced to V_{SS}.

Note 2: All modules are off, except internal reference, oscillator, and power-on reset (POR) and CKSEL bit is set to zero.

Note 3: The CPU and ADC are not on at the same time. The ADC and CPU currents are not additive.

Note 4: I_{DACn} does not include output buffer currents (I_{OPLGn} or I_{OPSMn}).

Note 5: For gains above 240, an additional digital gain can be provided by the CPU.

Note 6: The PWM input data is the 12-bit left-justified data in the 16-bit input field.

Note 7: PWM gain error measured as:

$$GE_{PWM} = \frac{PWM_{OUT}(F00Xh) - PWM_{OUT}(100Xh)}{3584} \times 100\%$$

Note 8: The internal reference voltage has a nominal value of 5V (4 × V_{BG}) even when V_{DD} is greater or less than 5VDC.

Note 9: Input-referred offset error is the ADC offset error divided by the PGA gain.

Note 10: When the CKIO is configured in output mode to observe the internal oscillator signal, the total current is above the specified limits.

Note 11: f_{CLK} must be within 5% of 4MHz.

Note 12: Allow a minimum elapsed time of 4.2ms when executing a FLASH erase command, before sending any other command. Allow a minimum elapsed time of 80μs between FLASH write commands.

Note 13: FLASH programming current is guaranteed by design.

Low-Power, Low-Noise Multichannel Sensor Signal Processor

TIMING CHARACTERISTICS

($V_{DDF} = V_{DD} = 4.5V$ to $5.5V$, $V_{SSF} = V_{SS} = 0V$, $f_{CLK} = 4.0MHz$, $T_A = T_{MIN}$ to T_{MAX} . Typical values are at $V_{DDF} = V_{DD} = 5.0V$, $V_{SSF} = V_{SS} = 0V$, $T_A = +25^{\circ}C$, unless otherwise noted.) (Note 1)

PARAMETER	SYMBOL	CONDITIONS		MIN	TYP	MAX	UNITS
Programming Temperature	T_{PROG}					125	$^{\circ}C$
Internal Oscillator Clock Frequency	f_{CLK}	OSC[4:0] = 00000		3.3	4.15	5.3	MHz
External Clock Frequency	f_{ECLK}	$V_{CKSEL} = 0$	Min	0.2			MHz
			Max	5			
External Master Clock Input Low Time	f_{ECLKIN_LO}	$t_{ECLK} = 1 / f_{ECLK}$		40		60	% t_{ECLK}
External Master Clock Input High Time	f_{ECLKIN_HI}	$t_{ECLK} = 1 / f_{ECLK}$		40		60	% t_{ECLK}
SERIAL INTERFACE (Figure 1)							
SCLK Setup to Falling Edge \overline{CS}	t_{SC}			30			ns
\overline{CS} Falling Edge to SCLK Rising Edge Setup Time	t_{CSS}			30			ns
\overline{CS} Idle Time	t_{CSI}	$f_{CLK} = 4MHz$		1.5			μs
\overline{CS} Period	t_{CS}	$f_{CLK} = 4MHz$		4			μs
SCLK Falling Edge to Data Valid Delay	t_{DO}	$C_{LOAD} = 200pF$				80	ns
Data Valid to SCLK Rising Edge Setup Time	t_{DS}			30			ns
Data Valid to SCLK Rising Edge Hold Time	t_{DH}			30			ns
SCLK High Pulse Width	t_{CH}			100			ns
SCLK Low Pulse Width	t_{CL}			100			ns
\overline{CS} Rising Edge to SCLK Rising Edge Hold Time	t_{CSH}			30			ns
\overline{CS} Falling Edge to Output Enable	t_{DV}	$C_{LOAD} = 200pF$				25	ns
\overline{CS} Rising Edge to Output Disable	t_{TR}	$C_{LOAD} = 200pF$				25	ns

Low-Power, Low-Noise Multichannel Sensor Signal Processor

MAX1464

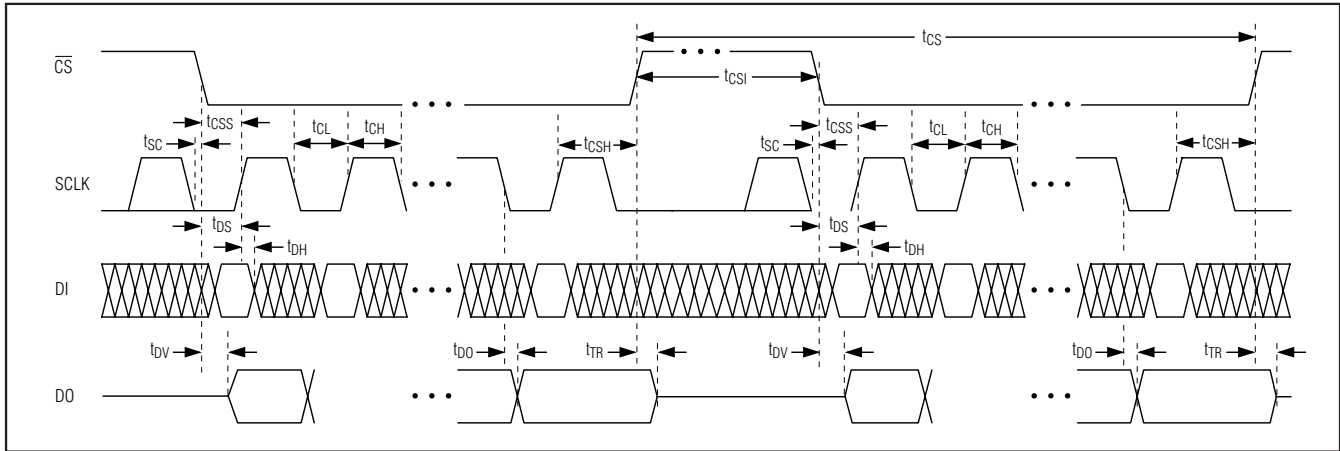
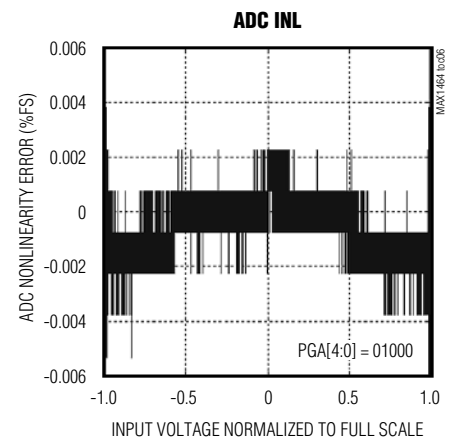
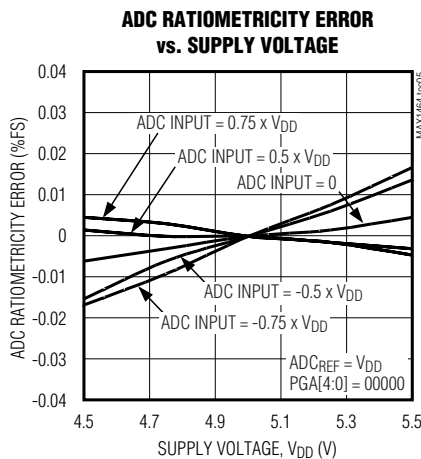
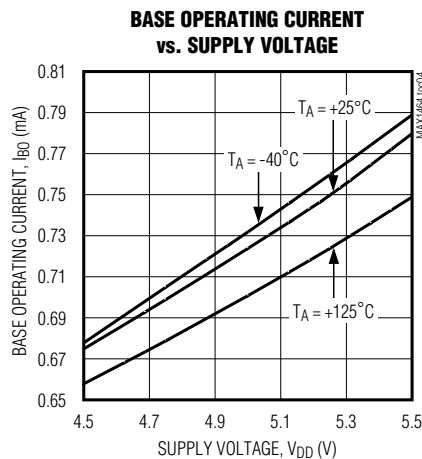
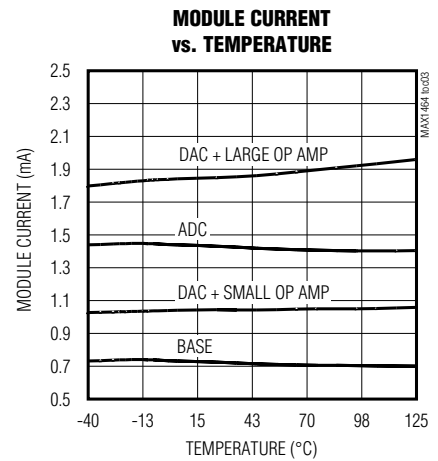
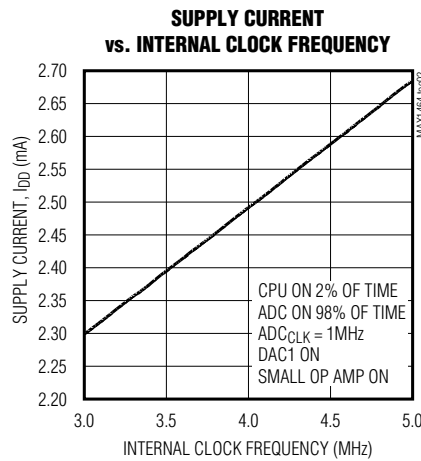
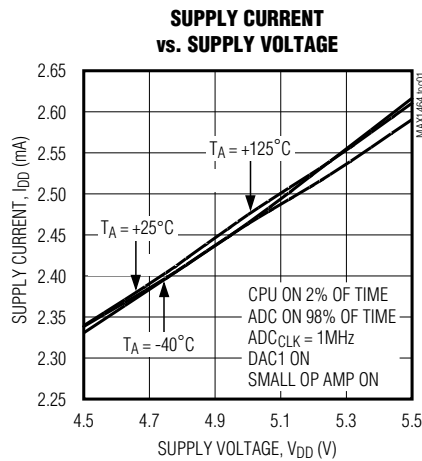

Figure 1. Serial Interface Timing Diagram

Typical Operating Characteristics

($V_{DD} = 5.0V$, $T_A = +25^\circ C$, unless otherwise noted.)



Low-Power, Low-Noise Multichannel Sensor Signal Processor

Typical Operating Characteristics (continued)

($V_{DD} = 5.0V$, $T_A = +25^\circ C$, unless otherwise noted.)

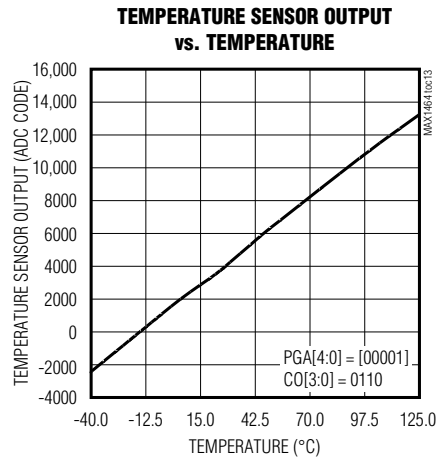
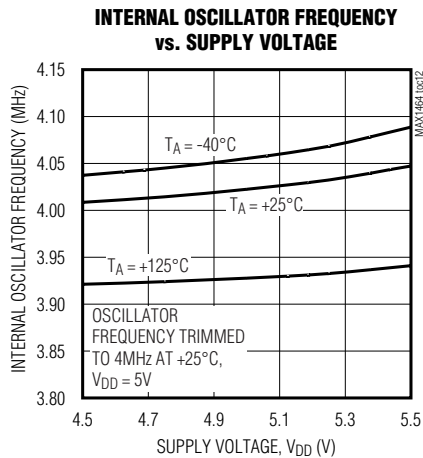
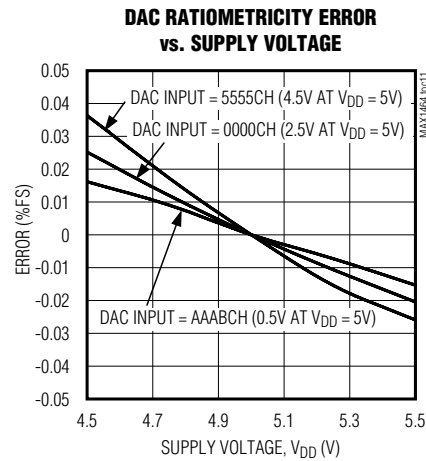
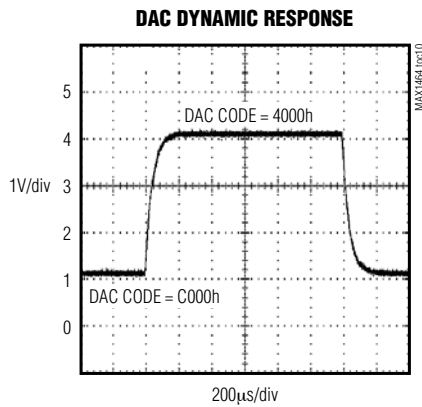
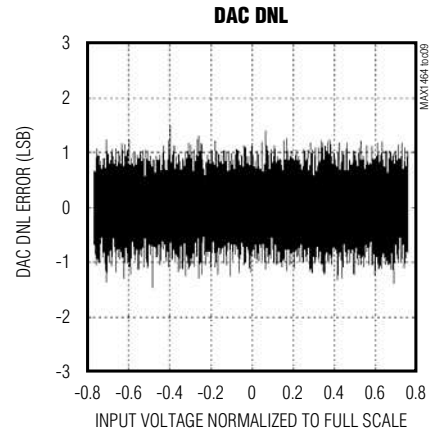
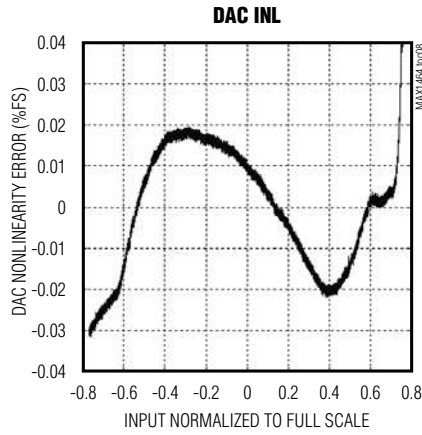
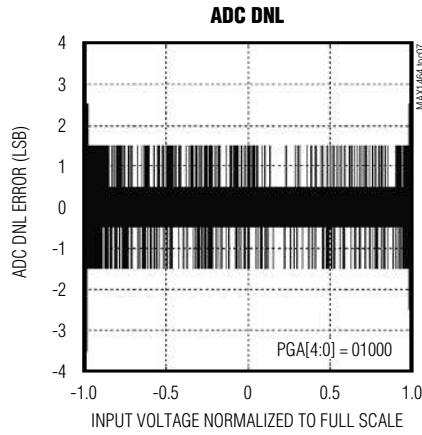

Low-Power, Low-Noise Multichannel Sensor Signal Processor

Pin Description

MAX1464

PIN	NAME	FUNCTION
1	OUT1SM	Small Op Amp 1 Output
2	AMP1M	Op Amp 1 Negative Input
3	AMP1P	Op Amp 1 Positive Input
4	OUT1LG	Large Op Amp 1 Output
5, 7	N.C.	No Connection
6	V _{DD}	Positive Supply Voltage Input. Bypass V _{DD} to V _{SS} with a 0.1μF ceramic capacitor.
8	CKSEL	Clock-Select Digital Input
9	CKIO	Clock Digital Input/Output
10	$\overline{\text{CS}}$	SPI Chip-Select Digital Input. Active low.
11	DO	SPI Data Output
12	DI	SPI Data Input
13	SCLK	SPI Interface Clock
14, 19	V _{SS}	Negative Power-Supply Input
15	V _{DDF}	Positive Supply Voltage for FLASH Memory. Bypass V _{DDF} to V _{SS} with a 0.1μF ceramic capacitor.
16	GPIO1	General-Purpose Digital Input/Output 1
17	GPIO2	General-Purpose Digital Input/Output 2
18	V _{SSF}	Negative Power-Supply Input for FLASH Memory
20	INM2	Negative Input for ADC Channel 2
21	INP2	Positive Input for ADC Channel 2
22	INM1	Negative Input for ADC Channel 1
23	INP1	Positive Input for ADC Channel 1
24	V _{REF}	External Reference Voltage Input for ADC and DACs
25	OUT2LG	Large Op Amp 2 Output
26	AMP2P	Op Amp 2 Positive Input
27	AMP2M	Op Amp 2 Negative Input
28	OUT2SM	Small Op Amp 2 Output

Low-Power, Low-Noise Multichannel Sensor Signal Processor

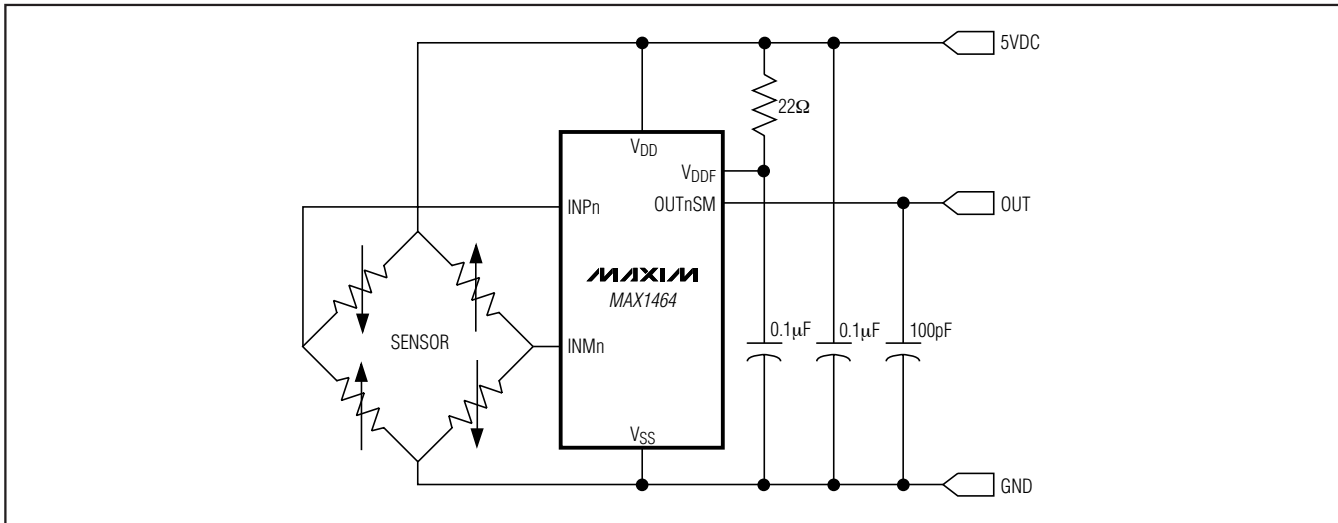

Figure 2. Basic Bridge Sensor Ratiometric Output Configuration

Typical Application Circuit

Analog ratiometric output configuration (Figure 2) provides an output that is proportional to the power-supply voltage. Ratiometricity is an important consideration for automotive, battery-operated instruments, and some industrial applications.

Detailed Description

The MAX1464 is a highly integrated, low-power, low-noise multichannel sensor signal processor optimized for industrial, automotive, and process-control applications, such as pressure sensing and compensation, RTD and thermocouple linearization, weight sensing and classification, and remote process monitoring with limit indication.

The MAX1464 incorporates a 16-bit CPU, user-programmable 4kB of FLASH memory, 128 bytes of FLASH user information, 16-bit ADC, two 16-bit DACs, two 12-bit PWM digital outputs, four rail-to-rail op amps, SPI interface, two GPIOs, and one on-chip temperature sensor.

Each sensor signal can be amplified, compensated for temperature, linearized, and the offset and full scale can be adjusted to the desired value. The MAX1464 can provide outputs as analog voltage (DAC) or digital (PWM, GPIOs), or simple on/off alarm indication (GPIOs). The uncommitted op amps can be used to implement 4–20mA current loops or for additional gain and filtering. Each DAC output is routed to either a small or large op amp. Large op amps are capable of driving heavier external loads. The unused circuit functions can be turned off to save power.

All sensor linearization and on-chip temperature compensation is done by a user-defined algorithm stored in FLASH memory. The user-defined algorithm is programmed over the serial interface and stored in 4kB of integrated FLASH memory.

The MAX1464 uses an internal 4MHz oscillator or an externally supplied 4MHz clock. CPU code execution and ADC operation is fully synchronized to minimize the noise interference of a CPU-based sensor processor system. The CPU sequentially executes instructions stored in FLASH memory.

Sensor Input

The MAX1464 provides two differential signal inputs, INP1-INM1 and INP2-INM2. These inputs can also be configured as four single-ended signals. Each input can have a common-mode range from V_{DD} to V_{SS} and a 0.99V/V to 244V/V programmable-gain range. The differential input signals are summed with the output of the coarse offset DAC (CO DAC) for offset correction prior to being amplified by the programmable-gain amplifier (PGA). The resulting signal is applied to the differential input of the ADC for conversion.

The CPU can be programmed to measure one or two differential inputs plus the internal temperature sensor defined in user-supplied algorithm. For example, the differential inputs can be measured many times while the temperature can be measured less frequently.

Low-Power, Low-Noise Multichannel Sensor Signal Processor

On-Chip Temperature Sensing

The on-chip temperature sensor changes +2mV/°C over the operating range. The ADC converts the temperature sensor in a similar manner as the sensor inputs. During an ADC conversion of the temperature sensor, the ADC automatically uses four times the internal 1.25V reference as the ADC full-scale reference (5V). The temperature data format is 15-bit plus sign in two's-complement format. Gain offset compensation can be programmed to utilize the full-scale range of the ADC. Offset compensation by the CO DAC is provided so that the nominal temperature measurement can be centered at the ADC output value. Use the CPU to provide additional digital gain and offset correction.

Output Format

There are two output modules in the MAX1464—DOP1 (DAC Op Amp PWM 1) and DOP2 (DAC Op Amp PWM 2). Each of the DOP modules contains a 16-bit DAC, a 12-bit digital PWM converter, a small op amp, and a large op amp with high-output-drive capability. Each module can be configured in several different modes to suit a wide range of output signal requirements. Either the DAC or the PWM can be selected as the primary output signal. The DAC output signal must be routed to one of the two op amps before being made available to a device pin. See the *DAC, Op Amp, PWM Modules (DPOn)* section for details. Additional digital outputs are available on the GPIOs.

Initialization

A user-defined initialization routine is required to configure the oscillator frequency and various analog modules, e.g., PGA gain, ADC resolution, ADC clock settings, etc. After the initialization routine, the CPU can start execution of the main program.

Power-On Reset (POR)

The MAX1464 contains a POR circuit to disable CPU execution until adequate V_{DD} and V_{DDF} voltage are available for operation. Once the power-on state has been reached, the MAX1464 is kept under reset condition for 250µs before the CPU starts execution. Below the POR threshold, all internal CPU registers are set to their POR default state. Power-on control bits for internal modules are reset to the OFF condition.

CPU Architecture

The CPU provides a wide range of functionality to be incorporated in an embedded system. The CPU can compensate nonlinear and temperature-dependent sensors, check for over/underlimit conditions, output sensor or temperature data as an analog signal or pulse-width-modulated digital signal, and execute control strategies.

The CPU can perform a limited amount of signal processing (filtering). A timer is included so that uniform sampling (equally spaced ADC conversions) of the input sensors can be performed.

The CPU registers and ports are implemented in volatile, static memory. There are several registers contained in various peripheral modules that provide module configuration settings, control functions, and data. These module registers are accessible through an indirect addressing scheme as described in detail in the *CPU Registers, CPU Ports, and Modules* sections. Figure 3 shows the CPU architecture.

CPU Registers

The MAX1464 incorporates a CPU with 16 internal registers. All the CPU registers have a 16-bit data word width. Five of the 16 registers have predefined functional operations that are dependent on the instruction being executed. The remaining registers are general purpose.

The CPU registers are embedded in the CPU itself and are not all directly accessible by the serial interface. The accumulator register (A), the pointer register (P), and the instruction (FLASH data) can be read through the serial interface when the CPU is halted. This enables a single-

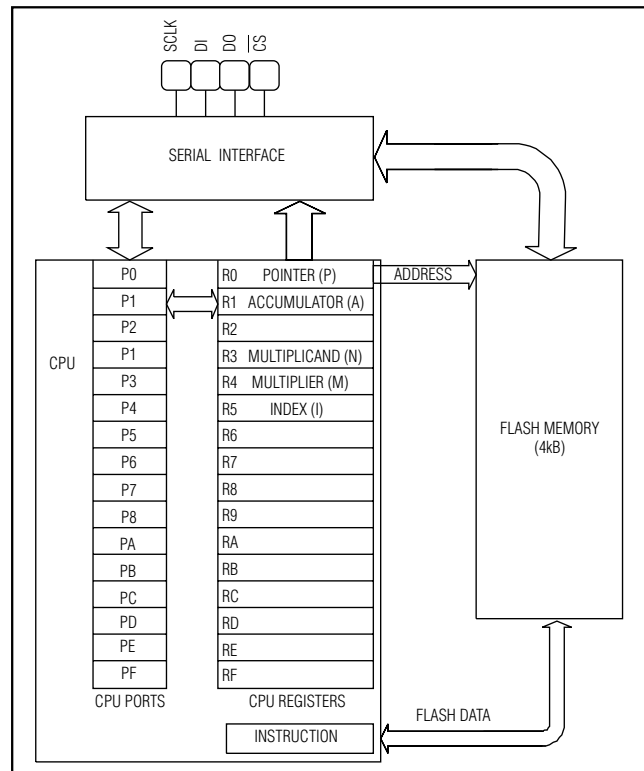

Figure 3. CPU Architecture

Low-Power, Low-Noise Multichannel Sensor Signal Processor

step mode of code execution to ease code writing and debugging. A special program instruction sequence is required to observe the other CPU registers. Table 1 lists the CPU registers.

CPU Ports

The MAX1464 incorporates 16 CPU ports that are directly accessible by the serial interface. All the CPU ports have a 16-bit data word width. The contents of the ports can be read and written by transferring data to and from the accumulator register (A) using the RDX and WRX instructions. No other CPU instructions act on the CPU ports. Three CPU ports PD, PE, and PF have uniquely defined operation for reading and writing data to and from the peripheral modules. All CPU ports are static and volatile. Table 2 lists the CPU ports.

Modules

The MAX1464 modules are the functional blocks used to process analog and digital signals to and from the CPU. Each module is addressed through CPU ports PD, PE, and PF, as described in the *CPU Ports* section. All modules use static, volatile registers for data retention. There are three types of module registers: configuration, data, and control. They are used to put a module into a particular mode of operation. Configuration registers hold configuration bits that control static settings such as PGA gain, coarse offset, etc. Data registers hold input data such as DAC and PWM input words or output data such as the result of an ADC conversion. Control registers are used to initiate a process (such as an ADC conversion or a timer) or to turn modules on and off (such as op amps, DAC outputs, PWM outputs, etc.) Table 3 lists the module registers.

ADC Module

The ADC module (Figure 4) contains a 9-bit to 16-bit sigma-delta converter with multiplexed differential and single-ended signal inputs, a CO DAC, four reference voltage inputs, two differential or four single-ended external inputs, and 15 single-ended internal voltages for measurement. The ADC output data is 16-bit two's-complement format. The conversion channel, modes, and reference sources are all set in ADC configuration registers. The conversion time is a function of the selected resolution and ADC clock frequency. The CPU can be programmed to convert any of the inputs and the internal temperature sensor in any desired sequence. For example, the differential inputs may be converted many times and conversions of temperature performed less frequently. See Table 4.

The ADC reference can be selected as V_{DD} for conversions ratiometric to the power supply, $2 \times V_{REF}$ input for conversions relative to an external voltage, and $V_{BG} \times 4$,

which is an internally generated bandgap reference voltage. Note that because V_{REF} external = 2.5V and $V_{BG} = 1.25V$, the ADC's reference voltage is always close to 5.0V. The ADC voltage reference is also used by the CO DAC to maintain a signal conversion that is completely ratiometric to the selected reference source.

The four analog inputs (INP1, INM1, INP2, INM2) and several internal circuit nodes can be multiplexed to the ADC for a single-ended conversion relative to V_{SS} . The selection of which circuit node is multiplexed to the ADC is controlled by the ADC_Control register. The ADC can measure each of the op-amp output nodes with gain for converting user-defined circuits or incorporating system diagnostic test functions. The DAC outputs can be converted by the ADC with either op amp arranged as unity-gain buffers on the DAC outputs. The internal power nodes, V_{DD} and V_{SS} , and the bandgap reference, V_{BG} can be multiplexed to the ADC for conversion as well. These measurement modes are defined and initiated in the ADC_Control register. See Tables 5 and 7 for the single-ended configuration.

ADC Registers

The ADC module has 10 registers for configuration, control, and data output. There are three conversion channels in the ADC; channel 1, channel 2, and temperature. Channels 1 and 2 are associated with the differential signal input pairs INP1-INM1 and INP2-INM2, respectively. The temperature channel is associated with the integrated temperature sensor. Each channel has two configuration registers (ADC_Config_nA and ADC_Config_nB where $n = 1, 2, \text{ or } T$) for setting conversion resolution, reference input, coarse offsets, etc. The data output from a conversion of channel 1, 2, or T is stored in the respective data output register ADC_Data_n where $n = 1, 2, \text{ or } T$. Each of the channels can be used to convert single-ended inputs as listed in Table 7. The ADC_Control register controls which channel is to be converted and what single-ended input, if any, is to be directed to that channel. See Tables 8 through 13.

Conversion Start

To initiate an ADC conversion, a word is written to the ADC_Control register with either CNVT1, CNVT2, or CNVTT bit set to a 1 (Table 6). When an ADC conversion is initiated, the CPU is halted and all CPU and FLASH activities cease. All CNVT1, CNVT2, and CNVTT bits are cleared after the ADC conversion is completed.

Upon completion of the conversion, the ADC result is latched into the respective ADC_Data_n register. In addition, the convert bits in control register 0 are all reset to zero. The CPU clock is then enabled and program execution continues.

Low-Power, Low-Noise Multichannel Sensor Signal Processor

MAX1464

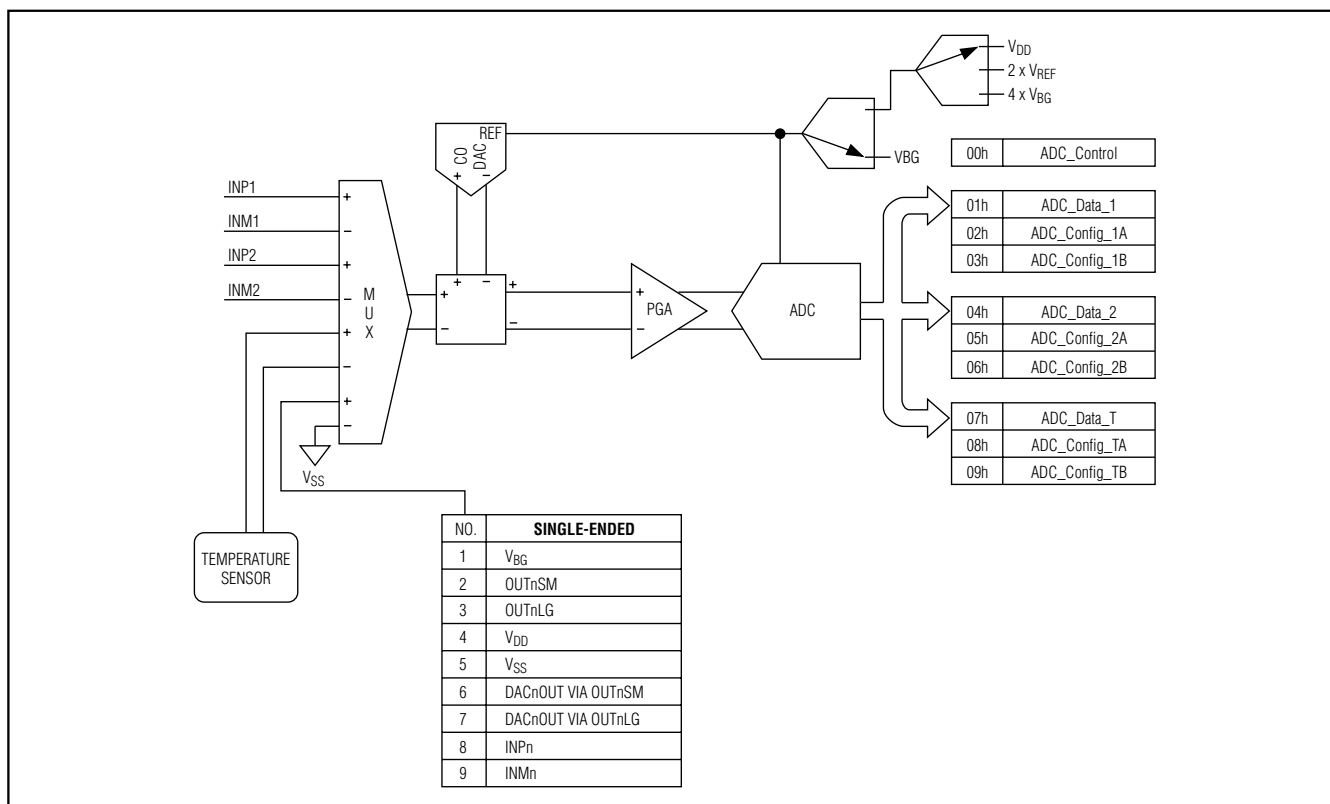

Figure 4. ADC Module

Single-ended inputs can be converted by either channel 1 or 2 by initiating a conversion on the appropriate channel with the SE[3:0] bits set to the desired single-ended input (Table 7). Several of the single-ended signals are converted with a fixed gain. The reduced gain of 0.7V/V allows signals at or near the supply rails to be converted without concern of saturation. Other single-ended signals can be converted with the full selectable PGA gain range.

Programmable-Gain Amplifier

The gain of the differential inputs and several single-ended inputs can be set to values between 0.99V/V to 244V/V as shown in Table 14. The PGA bits are set in ADC_Config_nA where n = 1, 2, or T. The gain setting must be selected prior to initiating a conversion.

ADC Conversion Time and Resolution

The ADC conversion time is a function of the selected resolution, ADC clock (f_{ADC}), and system clock frequency (f_{CLK}). The resolution can be selected from 9 bits to 16 bits in the ADC_Config_nA (where n = 1, 2, or T) register

by bits RES_n[2:0]. The lower resolution settings (9 bit) convert faster than the higher resolution settings (16 bit). The ADC clock f_{ADC} is derived from the primary system clock f_{CLK} by a prescaler divisor. The divisor can be set from 4 to 512, producing a range of f_{ADC} from 1MHz down to 7.8125kHz when f_{CLK} is operating at 4.0MHz. Other values of f_{CLK} produce other scaled values of f_{ADC} . See Tables 15 and 16.

Systems operating with very low power consumption benefit from the reduced f_{ADC} clock rate. Slower clock speeds require less operating current. Systems operating from a larger power consumption budget can use the highest f_{ADC} clock rate to improve speed performance over power performance.

The ADC conversion times for various resolution and clock-rate settings are summarized in Table 17. The conversion time is calculated by the formula:

$$t_{CONVERT} = \frac{\text{(no. of } f_{ADC} \text{ clocks per conversion)}}{f_{ADC}}$$

Low-Power, Low-Noise Multichannel Sensor Signal Processor

Coarse-Input Offset Adjustment

Differential input signals that have an offset can be partially nulled by the input coarse-offset (CO) DAC. An offset voltage is added to the input signal prior to gaining the signal. This allows a maximum gain to be applied to the differential input signal without saturating the conversion channel. The CO signal added to the differential signal is a percentage of the full-scale ADC reference voltage as referred to the ADC inputs. Low PGA gain settings add smaller amounts of coarse offset to the differential input. Large PGA gain settings enable correspondingly larger amounts of coarse offset to be added to the input signal. The CO DAC also applies to the temperature channel enabling offset compensation of the temperature signal. See Table 18.

Bias Current Settings

The analog circuitry within the ADC module operates from a current bias setting that is programmable. The programmable levels of operation are fractions of the full bias current. The operating power consumption of the ADC can be reduced at the penalty of increased conversion times that may be desirable in very-low-power applications. It is recommended operating the ADC at full bias when possible. The amount of bias as a fraction of full bias is shown in Table 19. The setting is controlled by the BIASn[2:0] bits in the ADC_config_nb registers where n = 1, 2, or T.

Reference Input Voltage Select

The ADC can use one of three different reference voltage inputs depending on the conversion channel and REF_n setting as shown in Table 20. The differential inputs can be converted ratiometrically to the supply voltage (V_{DD}), converted ratiometrically to an externally supplied voltage at V_{REF}, or converted nonratiometrically using a fixed voltage source derived from the internal bandgap voltage source. The temperature channel is always converted using the internal bandgap-derived voltage source and therefore is not selectable.

Output Sample Rate

Generally, the sensor and temperature data are converted and calculated by an algorithm in the execution loop. The output sample rate of the data depends on the conversion time, the CPU algorithm loop time, and the time to store the result in the DOP_n_DATA register. To achieve uniform sampling, the instruction code must be written to provide a consistent algorithm loop time, including branch instruction variations. This total loop time interval should be repeatable for a uniform output rate.

The MAX1464 has a built-in timer that can be used to ensure that the sampling interval is uniform. The timeout value can be set so the CPU computations and the read-

ing of the serial interface, if required, can be completed before timeout. The GPIO pins can be utilized to interrupt an external master microcontroller when the ADC conversion is done and/or when the CPU computations are done so the serial interface can be read quickly.

DAC, Op Amp, PWM Modules (DOP_n)

There are two output modules in the MAX1464—DOP1 and DOP2 (Figure 5). Each of the DOP modules contains a 16-bit DAC, a 12-bit digital PWM converter, a small op amp, and a large op amp with high-output-drive capability. Switches in the DOP module enable a range of interconnectivity among the converters, op amps, and the external pins. Either the DAC or the PWM can be selected as the primary output signal. The DAC output signal is routed to one of the op amps and made available to a device pin. The signal-switching arrangement also allows the unused op amp to be configured as an uncommitted device with all connections available to external pins.

The DAC and op amps have a power-control bit in the power module. When power is disabled, all circuits in the DAC and the op amp are disabled with inputs and outputs in a tri-state condition. The proper bits in the power module must be enabled for operation of the DAC and op amps.

The DAC input is a 16-bit two's-complement value. An input value of 0000h produces an output voltage of one half the DAC reference voltage. The DAC output voltage increases for positive two's-complement numbers, and decreases for negative two's-complement numbers.

The PWM input is a 12-bit two's complement value. It shares the same input register (DOP_n_Data) as the DAC, using the 12 MSBs of the 16-bit register. An input value of 000Xh produces a 50% duty cycle waveform at the output. The PWM output duty cycle increases for positive two's-complement numbers, and decreases for negative two's-complement numbers.

DOP_n Configuration Options

Each of the DOP modules can be configured in several different modes to suit a wide range of output signal requirements. The *Functional Diagram* shows the various switch settings of the configuration and control registers. In situations where configuration settings create a conflict in switch activation, a priority is applied to the switch logic to prevent the conflict.

The DAC and/or the PWM can be selected as the output signal source. The DAC output signal is routed to one of the op amps and made available to a device pin. Selecting the large op amp as the DAC output driver device enables a robust current drive capability for driving signals into low-impedance loads or across

Low-Power, Low-Noise Multichannel Sensor Signal Processor

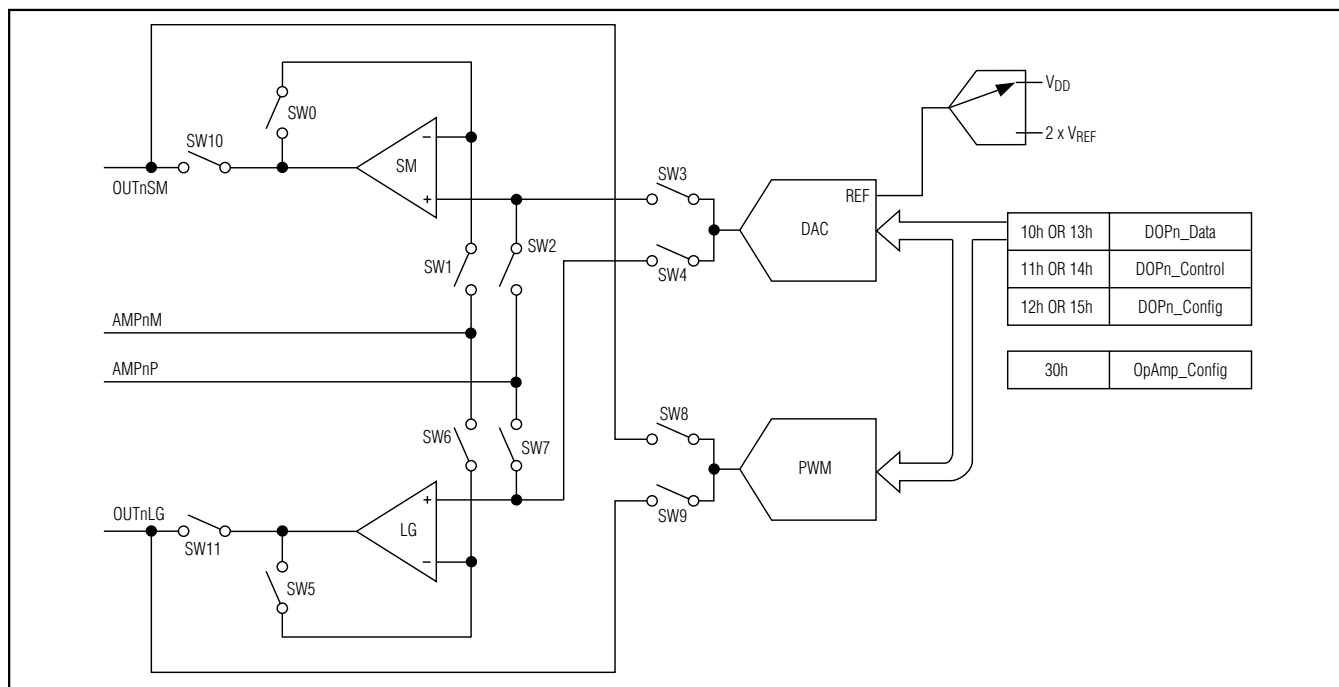

Figure 5. DOP1 and DOP2 Modules

long lengths of wire. The unity-gain buffer configuration is automatically selected, and it provides the DAC output signal directly to the device pin OUTnLG. With the large op amp selected, the small op amp can be used as an independent device for external circuit applications when the PWM is disabled. Alternatively, the PWM can also be enabled to drive the OUTnSM device pin, in which case the small op amp is OFF.

Selecting the small op amp as the DAC output driver device is useful for routing the output signal to other circuits in an embedded control system with high-impedance load connections. The unity-gain buffer configuration is automatically selected, and it provides the DAC output signal directly to the device pin OUTnSM. With the small op amp selected, the large op amp can be used as an independent device for external circuit applications when the PWM is disabled. Alternatively, the PWM can also be enabled to drive the OUTnLG device pin, in which case the large op amp is OFF.

The DAC has two reference voltage sources available by selection, V_{DD} and V_{REF} input. When the external reference is selected (V_{REF}), the actual DAC reference is $2 \times V_{REF}$. See V_{REF} to 2.5V for nominal operation. The output of the DAC is a voltage proportional to the reference voltage selected, where the proportionality scaling (DAC input) is set in the data input register DOPn_Data.

The DOP module also provides a 12-bit digital PWM output. At a nominal 4MHz frequency, the frequency of the PWM is 122Hz (PWM period = 8.192ms). The DAC and the PWM share the same input register, DOPn_Data, where the PWM uses the 12 MSBs, in two's-complement format. An input of 000Xh (4 LSBs are ignored) outputs a 50% duty cycle waveform at the selected output pin (either OUTnSM or OUTnLG). The PWM bit weight is $2\mu s$, at a nominal frequency of 4MHz. The minimum duty cycle is obtained when the input is 800Xh (duty cycle is $0 / 4096 = 0$), and the maximum duty cycle at 7FFXh (duty cycle is $4095 / 4096 = 99.98\%$). A new PWM input word is only effective at the end of a current PWM cycle, therefore preventing PWM glitches on the output.

Either the small or the large op amp in the DOP module can also be selected as an uncommitted op amp in the MAX1464. The op amps can be configured as a unity-gain buffer, where the output is internally connected to the negative terminal of the op amp, or a stand-alone op amp, where both AMPnM and AMPnP can be externally connected for various analog functions. In the case of a buffer, the device pin AMPnM is in high-impedance mode, as the feedback loop around the op amp is connected internally.

Low-Power, Low-Noise Multichannel Sensor Signal Processor

Every function of the DOP module can be selected individually (DAC, PWM, or op amp), or two out of the three functions of the DOP module can be selected at the same time (PWM and op amp, or DAC and PWM, or DAC and op amp), as there are only two output pins for the module, OUTnSM and OUTnLG. The various configuration options for the DOP are shown in Table 21. The PWRDAC and PWROP bits are in the power-on control register (address = 31h), and the remaining bits are in the DOP registers. See Tables 21 through 27.

Timer Module

The timer module (Figure 6) comprises a 12-bit counter, a 4-bit prescaler, and control and configuration registers. When the timer is enabled and initiated, the system master clock, MCLK, is prescaled by the divisor set by PS[3:0] in the TMR_Config register and the result applied to the 12-bit upcounter. When the counter value matches the timeout value TO[11:0] in register TMR_Config, bit TMDN is set to 1. The CPU can poll the timer done bit TMDN to check its status.

The timer module provides a feature that enables the CPU to be put into a low-power halt mode for the duration of the timer interval. Setting the ENAHALT bit in the TMR_Control register while starting the timer (setting the timer enable bit TMEN to 1), or while the timer is already enabled and counting halts the CPU at the present instruction until the TMDN bit becomes set by the counter. The CPU commences execution with the next instruction. All CPU registers and ports are fully static and retain all data during the elapsed time interval.

The time interval between TMEN being set to 1, and TMDN being set to 1 can be computed as follows:

$$\text{Time Interval} = (2 / f_{\text{OSC}}) \times \{(\text{prescale value } N) \times (\text{timeout value } \text{TO}[11:0]) + 1.5\}$$

The maximum time interval given $f_{\text{OSC}} = 4\text{MHz}$ clock is 786ms.

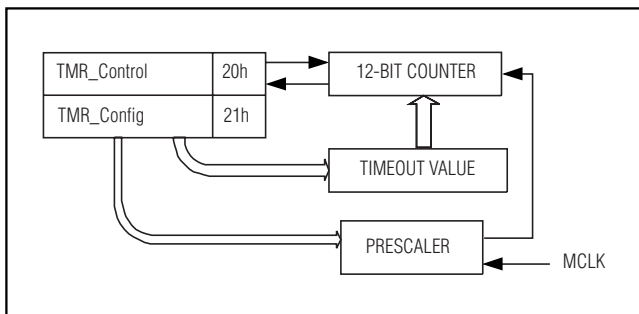

Figure 6. Timer Module

Power Control

The power to various subcircuits in the MAX1464 can be turned on and off by CPU control and by the serial interface. Unused subcircuits and modules can be turned off to reduce power consumption. The default state after power-on is all subcircuits and modules powered off. This enables low-power embedded systems to turn on only the needed modules after exiting a low-power CPU halt timer interval. Modules can be turned on and off as needed; however, care must be exercised to allow for module initialization and settling prior to use.

Oscillator Control

The MAX1464 has a fully integrated oscillator with a nominal 4MHz frequency. An external clock source can be used when the clock-select pin CKSEL = 0, operating all internal timing functions. CKIO can also be configured as an output source of the internal oscillator clock.

GPIO Module

The MAX1464 contains two general-purpose digital input/output (GPIO) modules, GPIO1 and GPIO2, which can be written and read by CPU control and by the serial interface. These two I/O pins operate independently of each other. They can be configured as inputs, outputs, or one input and one output. When configured as an input, there are two modes of sensing digital inputs; as a voltage or logic level, or as an edge detector. In edge-detector mode, either a rising or falling edge can be selected for detection. A bit is set in the GPIO control register upon detection of the selected edge.

The GPIO pins have nominal 100kΩ pulldown resistors to V_{SS} as in Figure 6. Pulldown resistors provide a low logic level when the pin is unconnected. The GPIO may also serve as an input pin and its state is read from the GPIO control register (Tables 28 and 29). When using the GPIO pin as a general-purpose output, its output state is defined by writing to the GPIO control register.

The GPIO pins can be configured as an alert output that goes low or high whenever a fault condition happens, e.g., remote sensor line disconnection, overflow conditions in the CPU program execution, etc.

All input and output control for the GPIO1 and GPIO2 pins are contained in GPIO1_Control (address = 40h) and GPIO2_Control (address = 41h), respectively. Figure 7 shows the GPIO1 and GPIO2 modules.

Serial Interface Timing and Operation

The MAX1464 serial interface is a high-speed asynchronous data input and output communication port, providing access to internal registers for calibration of embedded control sensor systems. All the FLASH memory is read and write accessible by the serial inter-

Low-Power, Low-Noise Multichannel Sensor Signal Processor

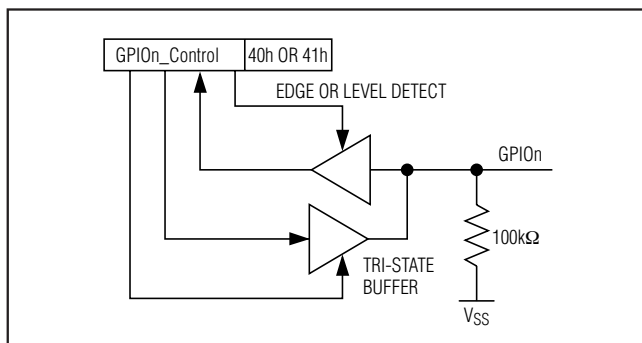

Figure 7. GPIO1 and GPIO2 Modules

face for programming of instruction code and calibration coefficients. The MAX1464 serial interface can operate in 4-wire SPI-compatible mode or in a 3-wire mode (default on power-up). In 3-wire mode, the DI and DO lines can be connected together, forming a bidirectional data line. The serial interface lines consist of chip-select (\overline{CS}), serial clock (SCLK), data in (DI), and data out (DO).

The MAX1464 serial interface is selected by asserting \overline{CS} low. The serial input clock, SCLK, is gated internally to begin sequencing the DI input data and outputting the output data onto DO. When \overline{CS} rises, the data that was clocked into DI is loaded into an internal register set (IRS[7:0]). The MAX1464 chip-select line \overline{CS} cannot be connected low continuously for normal operation.

The serial interface can be used both during sensor calibration, as well as during normal operation. Each byte of data written into the MAX1464 serial port contains a 4-bit addresses nibble (IRSA [3:0]) and a 4-bit data nibble (IRSD [3:0]). The IRS register holds both the IRSD and IRSA nibbles as follows:

$$\text{IRS [7:0]} = \text{IRSD [3:0]}, \text{IRSA [3:0]}$$

Four bytes of IRS information must be written into the serial interface to transfer 16 bits of data through IRSD into a MAX1464 internal register. All serial data written into the MAX1464 is transferred through the IRS register. The DI is read in with the LSB of the IRSA nibble first and the MSB of the IRSD nibble last. Figure 8 shows serial interface data input.

The IRSA bits are decoded to determine which register the IRSD bits should be latched into. The IRSA bits can address the DHR, the PFAR, the CR, and the IMR.

All serial data read from the serial interface is sourced from the 16-bit DHR. Any data to be read by the serial interface must first be placed into the internal DHR register before being accessible for reading by the serial interface.

The entire 16-bit content of the DHR register is read out through the DO pin by applying 16 successive clock pulses to SCLK while \overline{CS} remains low. DHR is clocked out MSB bit first. Figure 9 shows the 4-wire mode data read from the DHR register

In 4-wire mode, data is transferred into DI during the clocking of data out of DO. Therefore, the last 8 bits clocked into the DI pin during this data transfer are latched into the IRS register and decoded when \overline{CS} returns high.

When the MAX1464 serial interface is configured in 3-wire mode, the 16-bit DHR data is read out immediately following the command for 3-wire mode enable. Figure 10 shows the 3-wire enable command (IRS[7:0] = 19h) clocked into DI with a subsequent 16-bit read of DHR on DO. DO remains in high impedance (tri-state) until the 3-wire enable command is received. Then DO goes into low-impedance drive mode during the next low cycle of \overline{CS} . As SCLK is clocked 16 times, the data in DHR is clocked out at DO. The 3-wire enable command is the command that sets the MAX1464 ready for output on DO on the next low cycle of \overline{CS} . Following the DHR output on the low cycle of \overline{CS} , the DO line returns to high-impedance state until the next 3-wire enable command is received. The MAX1464 can receive an indefinite number of inputs to DI without the need for a 3-wire enable command to be received.

When the IRSD[3:0] nibble is written to the command register (CR), i.e., when IRSA[3:0] = 1000, the nibble is decoded and a command operation is initiated. The command register decoding is shown in Table 39.

When the IRSD[3:0] nibble is written to the IMR, i.e., when IRSA[3:0] = 1000, the nibble is decoded and a command operation is initiated. The IMR decoding is shown in Table 40.

Note that after power is applied and the POR function completes, the serial interface default is the 3-wire mode for receiving data on DI only. The DO line is a high-impedance output until the MAX1464 receives either the 4-wire or 3-wire mode command in the IMR. In the case of a 3-wire mode command, DO switches from a high-impedance state to a driving state only for the next cycle of \overline{CS} , returning to high impedance afterwards.

All commands, with the exception of programming or erasing the FLASH memory, are completed within eight internal master clock cycles of \overline{CS} returning from low to high. This is 4 μ s for a 4MHz oscillator frequency or external clock input (1 internal master clock = 2 external/internal oscillator periods). FLASH memory programming and erasing require additional time of 80 μ s and 4.2ms, respectively.

Low-Power, Low-Noise Multichannel Sensor Signal Processor

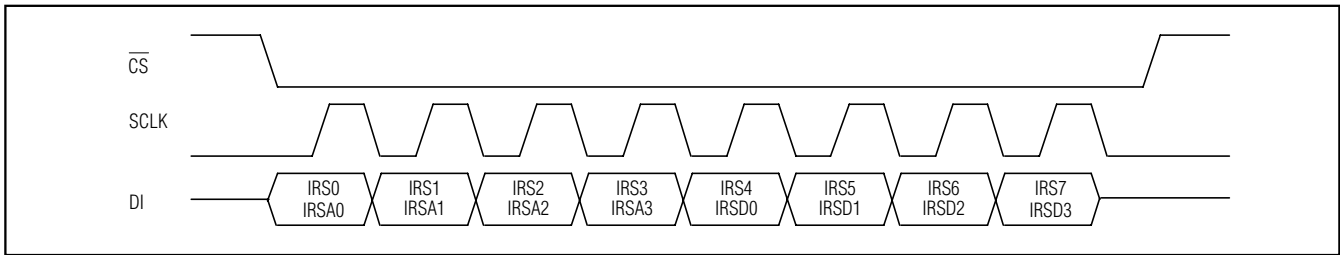

Figure 8. Serial Interface Data Input

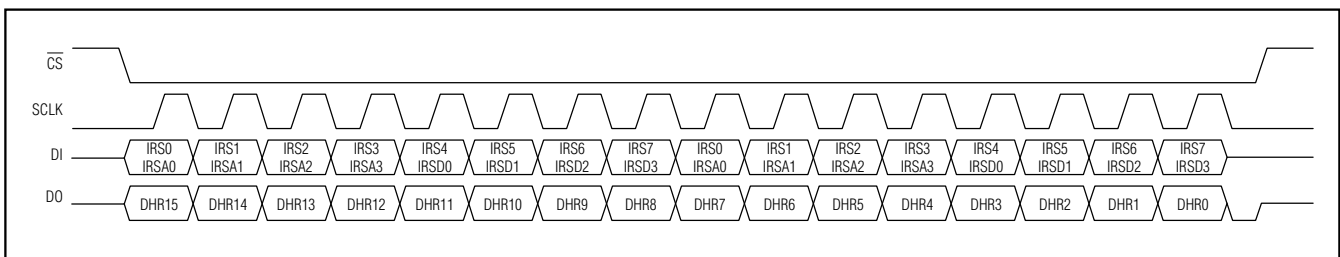

Figure 9. 4-Wire Mode Data Read from DHR Register

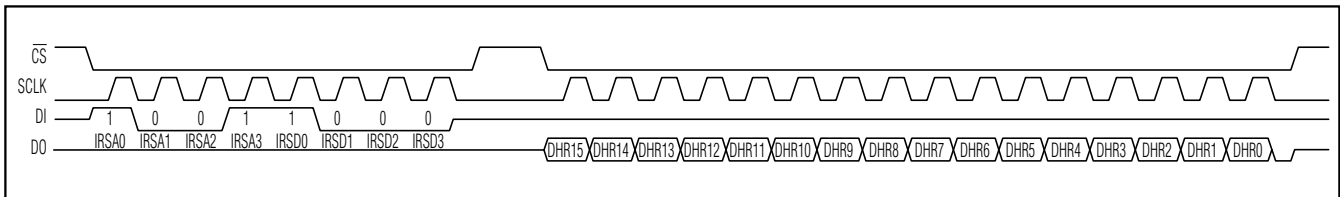

Figure 10. 3-Wire Mode Data Read from DHR Register

FLASH Memory

There are 4096 bytes of programmable/erasable FLASH memory for CPU program instructions and coefficients storage. In addition, there are 128 bytes of FLASH memory accessible only by the serial interface for storage of user information data.

These two FLASH memory locations are separated as partitions. The program/coefficient memory is FLASH partition 0 and the information memory is FLASH partition 1. Each partition is accessible by the serial interface for reading, erasing, and writing data. Program/coefficient memory partition 0 is accessible by the CPU as read only, and partition 1 is not accessible by the CPU. The CPU cannot erase or write data to either of the FLASH memory partitions.

FLASH partition 0 is selected during the POR cycle. FLASH partition 1 is selected by sending the halt CPU command (IRS[7:0] = 78h) and changing the partition selected by sending the change partition command

(IRS[7:0] = F8h). A following halt command (IRS[7:0] = 78h) resets the selected partition to partition 0.

Modifying the FLASH Contents

The MAX1464 FLASH memory contents must be erased (contents = FFh) before the desired contents can be written. There is no individual byte-erase command, but either a total-erase command (IRS[7:0] = E8h) where all the selected partition is erased (4kB for partition 0 or 128 bytes for partition 1) or a page-erase command (IRS[7:0] = D8h), where only 64 bytes are erased, and the page is selected by PFAR[11:6]. There are 64 pages in FLASH partition 0, and only 2 pages in FLASH partition 1.

The programming of the MAX1464 FLASH memory must use the following procedure (all the commands are to be sent through the serial interface, and are hexadecimal values of IRS[7:0]):

Low-Power, Low-Noise Multichannel Sensor Signal Processor

- 1) Halt the CPU:
78
- 2) If partition 1 is to be modified, enter the following command:
F8
Otherwise, partition 0 is selected.
- 3) Turn off all analog modes:

03 02 01 00	(write 0000h to DHR[15:0])
D4	(write Dh to PFAR[3:0])
08	(write DHR, 1000h to CPU port pointed by PFAR[3:0], port D)
03 02 31 10	(write 0031h to DHR[15:0])
E4	(write Eh to PFAR[3:0])
08	(write DHR, 0031h to CPU port pointed by PFAR[3:0], port E)
83 02 01 00	(write 8000h to DHR[15:0])
F4	(write Fh to PFAR[3:0])
08	(write DHR, 8000h to CPU port pointed by PFAR[3:0], port F)

At this point, all the MAX1464 analog modules are off.
- 4) For erasing the whole partition, send the following command:
E8
Otherwise, if only a page erase is required, first write PFAR[11:6] with the page address, as:
07 X6 X5 04 (write **0XX0h** to PFAR[15:0])
Note that the 2 lower bits of PFAR[7:4] should be zero, and only the upper 2 bits of that nibble should be set to the desired value. Then, after writing the page address, send the page-erase command:
D8
- 5) Wait at least 4.2ms before sending any other command to allow the necessary time for the erase operation to complete.
- 6) Write the address of the FLASH byte to be written to PFAR[15:0]:
07 X6 X5 X4 (write **0XXXh** to PFAR[15:0])
- 7) Write the contents of the byte to DHR[7:0]:
X1 X0 (write **XXh** to DHR[7:0], high nibble at DHR[7:4])
- 8) Send the command to execute the FLASH write:
18
- 9) Repeat steps 6, 7, and 8 for all the bytes to be written. It is not necessary to send the whole address and data for every byte that is written. Only the nibbles that are modified in the PFAR and in the DHR from previous values must be changed. The time interval between successive write commands (18h) must be at least 80µs.
- 10) If partition 1 was selected in step 2, and the user wants to switch back to partition 0, send the following command:
78
At this point, partition 0 is selected. The user may want to go back to step 4 to program partition 0, or just continue on.

Reading the FLASH Contents

The procedure to read the FLASH contents is no different from reading any other information from the MAX1464. The FLASH contents must be copied to the DHR and read through the serial interface:

- 1) If the CPU is not halted, halt the CPU:
78
- 2) If partition 1 is to be read, enter the following command:
F8
Otherwise, partition 0 is selected.
- 3) Write the address of the flash byte to be read to PFAR[15:0]:
07 X6 X5 X4 (write **0XXXh** to PFAR[15:0])
- 4) Copy the contents of FLASH addressed by PFAR to DHR:
38
- 5) If the interface is configured in 3-wire mode, send 19
to enable DO on the next \overline{CS} cycle. Then tristate the DI driver, and send 16 SCLK pulses on the following \overline{CS} cycle, and DO outputs DHR[15:0]. The FLASH data is present at DHR[7:0]. See Figure 10 for details.
If the interface is configured in 4-wire mode, there is no need to enable the DO line, as it has already been enabled by a previous IRS command 09h. Send the 16 SCLK pulses and retrieve the data on the DO line.
- 6) Repeat steps 3, 4, and 5 for every byte to be read. Only the nibbles that are modified in the PFAR register are required to be sent.

Low-Power, Low-Noise Multichannel Sensor Signal Processor

Program and Coefficient Memory

The program and coefficient memory, FLASH partition 0, is addressed by the CPU and by the serial interface sequentially from 0000h (0 dec) to 0FFFh (4095 dec). Program execution by the CPU always begins at address 0000h and proceeds toward 0FFFh in 1-byte increments.

Although both the CPU and the serial interface can address a 16-bit field, the FLASH size only uses 12 bits. Therefore, the leading 4 MSBs of the address field are ignored. It is advisable to have all leading bits of the 16-bit address in PFAR[15:0] set to zero.

The FLASH memory in partition 0 can be erased in individual 64-byte pages using the page-erase command, or erased in bulk using the all-erase command. The information data memory (partition 1) is unaffected by any operation performed on partition 0.

Information Data Memory

The information data memory, FLASH partition 1, is addressed by bytes sequentially from 00h (0 dec) to 7Fh (127 dec). The addressed byte should have all leading bits of the 16-bit address in PFAR[15:0] set to zero.

The FLASH memory in partition 1 has only two 64-byte pages that can be erased separately using the page-erase command, or erased together using the all-erase command. Data in partition 0 is not affected by any operation performed on partition 1.

MAX1464 CPU Instruction Set

The MAX1464 CPU has 16 instructions used to perform all calculations for sensor compensation, linearization, and signal output functions. Each instruction comprises a 4-bit op code and a 4-bit CPU register address. The op code describes what operation to perform; the register address describes what register, or registers, to perform the operation on.

Instruction Format

All instructions are single-byte instructions with the exception of load data from instruction memory. LDX fetches the 2 following bytes of instruction memory and loads them into a register. This is how calibration and compensation coefficients are stored within the MAX1464. Any number of coefficients can be stored in instruction memory. The instruction code format is as follows:

COMMAND OP CODE (BITS 7–4)				REGISTER OP CODE (BITS 3–0)			
Bit 7	Bit 6	Bit 5	Bit 4	Bit 3	Bit 2	Bit 1	Bit 0
MSB				LSB			

Instruction Set Details

LDX Load Register X

Op-code: 0000 XXXXBINARY 0Xh

Operation:

X-register ← [PC+1] : [PC+2]

PC-register ← PC + 3 (point to next instruction)

CPU Cycles required:

3 cycles

Instruction:

Loads the next 2 bytes of program memory into CPU register X. Register X can be any of the 16 CPU registers. Program counter (PC) is incremented twice during the fetches of the next 2 bytes and incremented a third time to point to the next instruction in program memory.

Two's-complement data format is preserved.

No branching occurs.

No other registers are affected.

CLX Clear Register X

Op-code: 0001 XXXXBINARY 1Xh

Operation:

X-register ← 0000h

PC-register ← PC + 1 (point to next instruction)

CPU Cycles required:

1 cycle

Description:

Clear the contents of register X to 0000h.

Register X can be any of the 16 CPU registers.

PC is incremented once to point to the next instruction in program memory.

Two's-complement data format is preserved.

No branching occurs.

No other registers are affected.

ANX AND Register X with Register A

Op-code: 0010 XXXXBINARY 2Xh

Operation:

A-register ← A-register AND X-register

PC-register ← PC + 1 (point to next instruction)

CPU Cycles required:

1 cycle

Low-Power, Low-Noise Multichannel Sensor Signal Processor

Description:

Perform a 16-bit logical AND operation, bit for bit, on the contents of the A-register and the contents of the X-register. Store the 16-bit result back into the A-register. The previous contents of the A-register are overwritten and lost.

Register X can be any of the 16 CPU registers.

PC is incremented once to point to the next instruction in program memory.

Two's-complement data format is not preserved.

No branching occurs.

No other registers are affected.

ORX OR Register X with Register A

Op-code: 0011 XXXXBINARY 3Xh

Operation:

A-register ← A-register OR X-register

PC-register ← PC + 1 (point to next instruction)

CPU Cycles required:

1 cycle

Description:

Perform a 16-bit logical OR operation, bit for bit, on the contents of the A-register and the contents of the X-register. Store the 16-bit result back into the A-register. The previous contents of the A-register are overwritten and lost.

Register X can be any of the 16 CPU registers.

PC is incremented once to point to the next instruction in program memory.

Two's-complement data format is not preserved.

No branching occurs.

No other registers are affected.

ADX ADD Register X to Register A

Op-code: 0100 XXXXBINARY 4Xh

Operation:

A-register ← A-register + X-register

PC-register ← PC + 1 (point to next instruction)

CPU Cycles required:

1 cycle

Description:

Perform a 16-bit arithmetic addition of the A-register and the contents of the X-register. Store the low 16 bits of the result back into the A-register. Any overflow bit resulting from the addition operation is lost. The previ-

ous contents of the A-register are overwritten and lost.

Register X can be any of the 16 CPU registers.

PC is incremented once to point to the next instruction in program memory.

Two's-complement data format is preserved.

No branching occurs.

No other registers are affected.

STX Store Register X

Op-code: 0101 XXXXBINARY 5Xh

Operation:

X-register ← A-register

PC-register ← PC + 1 (point to next instruction)

CPU Cycles required:

1 cycle

Description:

Perform a 16-bit move operation from the A-register into the X-register. The A-register contents are unchanged. The previous contents of the X-register are overwritten and lost.

Register X can be any of the 16 CPU registers.

PC is incremented once to point to the next instruction in program memory.

Two's-complement data format is preserved.

No branching occurs.

No other registers are affected.

SLX Shift Left Register X

Op-code: 0110 XXXXBINARY 6Xh

Operation when X ≠ 6h:

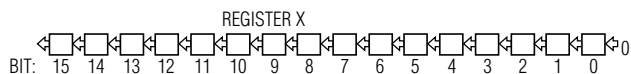

Operation when X = 6h:

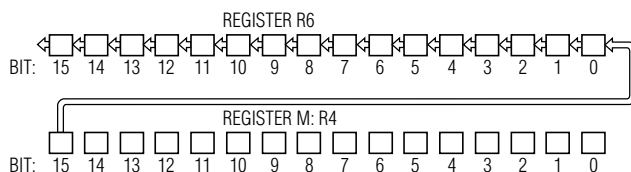

PC-register ← PC + 1 (point to next instruction)

CPU Cycles required:

1 cycle

Low-Power, Low-Noise Multichannel Sensor Signal Processor

Description:

Perform a 16-bit shift-left operation on the contents of X-register. The most significant bit, bit 15, is truncated and lost. If register X is any CPU register other than register R6, then a zero is appended into the LSB, bit 0. If X is CPU register R6, then the data appended into the LSB bit 0 is copied from the MSB of register R4. The contents of register R4 are not affected. The operation does not preserve the two's-complement sign bit-15. The operation is equivalent to an arithmetic multiplication by 2 on an unsigned integer value stored in register X. The result is stored back into the X-register. The previous contents of the X-register are overwritten and lost.

Register X can be any of the 16 CPU registers.

PC is incremented once to point to the next instruction in program memory.

Two's-complement data format is not preserved.

No branching occurs.

No other registers are affected.

SRX Shift Right Register X

Op-code: 0111 XXXXBINARY 7Xh

Operation

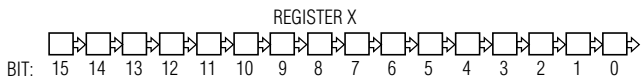

PC-register \leftarrow PC + 1 (point to next instruction)

CPU Cycles required:

1 cycle

Description:

Perform a 15-bit shift-right operation on the contents of X-register, preserving the contents of the two's-complement sign bit-15 and propagating the sign bit, bit-15, into bit-14. The least significant bit, bit 0, is truncated and lost. The operation is equivalent to an arithmetic division by 2. The result is stored back into the X-register. The previous contents of the X-register are overwritten and lost.

Register X can be any of the 16 CPU registers.

PC is incremented once to point to the next instruction in program memory.

Two's-complement data format is preserved.

No branching occurs.

No other registers are affected.

INX

Increment Register X

Op-code: 1000 XXXXBINARY 8Xh

Operation:

X-register \leftarrow X-register + 1

PC-register \leftarrow PC + 1 (point to next instruction)

CPU Cycles required:

1 cycle

Description:

Perform a 16-bit increment operation on the contents of the X-register. Should the increment result in an overflow, the overflow bit is truncated and lost. The result is stored back into the X-register. The previous contents of the X-register are overwritten and lost.

Register X can be any of the 16 CPU registers.

PC is incremented once to point to the next instruction in program memory.

Two's-complement data format is preserved.

No branching occurs.

No other registers are affected.

DEX

Decrement Register X

Op-code: 1001 XXXXBINARY 9Xh

Operation:

X-register \leftarrow X-register - 1

PC-register \leftarrow PC + 1 (point to next instruction)

CPU Cycles required:

1 cycle

Description:

Perform a 16-bit decrement operation on the contents of the X-register. Should the decrement result in an underflow, the underflow bit is truncated and lost. The result is stored back into the X-register. The previous contents of the X-register are overwritten and lost.

Register X can be any of the 16 CPU registers.

PC is incremented once to point to the next instruction in program memory.

Two's-complement data format is preserved.

No branching occurs.

No other registers are affected.

NGX

Negate Register X

Op-code: 1010 XXXXBINARY AXh

Operation:

X-register \leftarrow NOT X-register

Low-Power, Low-Noise Multichannel Sensor Signal Processor

PC-register ← PC-register + 1 (point to next instruction)

CPU Cycles required:

1 cycle

Description:

Perform a 16-bit logical NOT operation on the contents of the X-register. Each bit is flipped to its complementary value. The result is stored back into the X-register. The previous contents of X-register are overwritten and lost.

Register X can be any of the 16 CPU registers.

PC is incremented once to point to the next instruction in program memory.

Two's-complement data format is not preserved.

No branching occurs.

No other registers are affected.

BPX **Branch If Positive Or Zero**

Op-code: 1011 XXXXBINARY BXh

Operation:

If MSB(Register I) = 0 then:

PC-register ← PC-register + X-register

Else:

PC-register ← PC + 1 (point to next instruction)

CPU Cycles required:

1 cycle

Description:

Perform a 16-bit check of I-register for a positive (two's complement) or zero value and branch the number of instructions indicated in register-X. The test operation checks the most significant bit, bit-15, for a 0B and, if true, adds the contents of the X-register to the program counter register. This causes an immediate jump to the new program memory location. The next instruction to execute is fetched from the program memory byte pointed to by the new contents of the PC-register.

A 1B in bit-15 of the I-register is indicative of a negative number (two's complement) to which the test for positive-or-zero value fails. This causes the "else" operation to be performed and the PC-register is incremented by one pointing to the next sequential instruction in program memory to be executed. The effect bypasses the branch mechanism and normal, sequential, code execution results.

The next instruction to execute is fetched from the program memory byte pointed to by the new contents of the PC-register. The previous contents of the PC-register are overwritten and lost.

Two's-complement data format is preserved.

Branching may occur.

No other registers are affected.

BNX **Branch If Not Zero**

Op-code: 1100 XXXXBINARY CXh

Operation:

If I-register ≠ 0000h then:

PC-register ← PC-register + X-register

Else:

PC-register ← PC-register + 1 (point to next instruction)

CPU Cycles required:

1 cycle

Description:

Perform a 16-bit check of the I-register for a nonzero condition and, if true, add the contents of the X-register to the program pointer register. This causes an immediate jump to the new program memory location. The next instruction to execute is fetched from the program memory byte pointed to by the new contents of the PC-register.

A 1B in any bit of the I-register is indicative of a nonzero number to which the test for a zero value fails. This causes the "else" operation to be performed and the PC-register is incremented by one pointing to the next sequential instruction in program memory to be executed. The effect bypasses the branch mechanism and normal, sequential, code execution results.

The next instruction to execute is fetched from the program memory byte pointed to by the new contents of the PC-register. The previous contents of the PC-register are overwritten and lost.

Two's-complement data format is preserved.

Branching may occur.

No other registers are affected.

RDX **Read Port X**

Op-code: 1101XXXXBINARY DXh

Operation:

A-register ← port-X

PC-register ← PC + 1 (point to next instruction)