



Chipsmall Limited consists of a professional team with an average of over 10 year of expertise in the distribution of electronic components. Based in Hongkong, we have already established firm and mutual-benefit business relationships with customers from,Europe,America and south Asia,supplying obsolete and hard-to-find components to meet their specific needs.

With the principle of "Quality Parts,Customers Priority,Honest Operation,and Considerate Service",our business mainly focus on the distribution of electronic components. Line cards we deal with include Microchip,ALPS,ROHM,Xilinx,Pulse,ON,Everlight and Freescale. Main products comprise IC,Modules,Potentiometer,IC Socket,Relay,Connector.Our parts cover such applications as commercial,industrial, and automotives areas.

We are looking forward to setting up business relationship with you and hope to provide you with the best service and solution. Let us make a better world for our industry!



Contact us

Tel: +86-755-8981 8866 Fax: +86-755-8427 6832

Email & Skype: info@chipsmall.com Web: www.chipsmall.com

Address: A1208, Overseas Decoration Building, #122 Zhenhua RD., Futian, Shenzhen, China



MAX14782E

500Kbps 3.3V to 5V RS-485/RS-422 Transceiver with $\pm 35\text{kV}$ HBM ESD Protection

General Description

The MAX14782E is a 3.3V to 5V ESD-protected transceiver intended for half-duplex RS-485/RS-422 communication up to 500kbps. The device is optimized for extended cable runs while maximizing tolerance to noise.

The MAX14782E integrated protection features include short-circuit-protected outputs, hot-swap functionality, and a true fail-safe receiver, guaranteeing a logic-high receiver output when inputs are shorted or open. Hot-swap capability eliminates undesired transitions on the bus during power-up or hot insertion.

The transceiver draws 1.9mA (typ) supply current when unloaded or when fully loaded with the drivers disabled and draws less than 10 μA (max) of supply current in low-power shutdown mode.

The MAX14782E is available in 8-pin μMAX ®, 8-pin SO, and small, 8-pin (3mm x 3mm) TDFN-EP packages. All packages operate over the -40°C to +125°C temperature range.

Applications

- Motion Controllers
- Field Bus Networks
- Encoder Interfaces
- Backplane Buses

Benefits and Features

- Integrated Protection Increases Robustness
 - High ESD Protection
 - $\pm 35\text{kV}$ HBM ESD
 - $\pm 20\text{kV}$ Air Gap IEC 61000-4-2 ESD
 - $\pm 12\text{kV}$ Contact IEC 61000-4-2 ESD
 - Short-Circuit-Protected Outputs
 - True Fail-Safe Receiver
 - Hot-Swap Capability
- 3V to 5.5V Supply Voltage Range
- Data Rates up to 500kbps
- -40°C to +125°C Operating Temperature
- Allows Up to 32 Transceivers On the Bus
- Low 10 μA (max) Shutdown Current
- Saves Board Space
 - Available in 8-pin μMAX , SO, and TDFN-EP Packages

Ordering Information/Selector Guide

PART	SUPPLY RANGE	DATA RATE (MAX)	TEMP RANGE	PIN-PACKAGE
MAX14782EASA+	3.0V to 5.5V	500kbps	-40°C to +125°C	8 SO
MAX14782EATA+	3.0V to 5.5V	500kbps	-40°C to +125°C	8 TDFN-EP*
MAX14782EAUA+	3.0V to 5.5V	500kbps	-40°C to +125°C	8 μMAX

μMax is a registered trademark of Maxim Integrated Products, Inc.

+Denotes lead(Pb)-free/RoHS-compliant package.

*EP = Exposed paddle.

Absolute Maximum Ratings

(Voltages referenced to GND.)

V _{CC}	-0.3V to +6.0V
RO	-0.3V to (V _{CC} + 0.3V)
RE, DE, DI	-0.3V to +6.0V
A, B (V _{CC} ≥ 3.6V)	-8.0V to +13.0V
A, B (V _{CC} < 3.6V)	-9.0V to +13.0V
Short-Circuit Duration (RO, A, B) to GND	Continuous
Operating Temperature Range	
MAX14782EA_	-40°C to +125°C

Junction Temperature	+150°C
Storage Temperature Range	-65°C to +150°C
Continuous Power Dissipation (T _A = +70°C)	
SO (derate at 7.6mW/°C above +70°C)	606mW
TDFN-EP (derate at 24.4mW/°C above +70°C)	1951mW
μMAX (derate at 4.8mW/°C above +70°C)	387mW
Lead Temperature (soldering, 10s)	+300°C
Soldering Temperature (reflow)	+260°C

Stresses beyond those listed under "Absolute Maximum Ratings" may cause permanent damage to the device. These are stress ratings only, and functional operation of the device at these or any other conditions beyond those indicated in the operational sections of the specifications is not implied. Exposure to absolute maximum rating conditions for extended periods may affect device reliability.

Package Thermal Characteristics (Note 1)

Junction-to-Case Thermal Resistance (θ_{JC})

SO	38°C/W
TDFN-EP	8°C/W
μMAX	42°C/W

Junction-to-Ambient Thermal Resistance (θ_{JA})

SO	132°C/W
TDFN-EP	41°C/W
μMAX	206°C/W

Note 1: Package thermal resistances were obtained using the method described in JEDEC specification JESD51-7, using a four-layer board. For detailed information on package thermal considerations, refer to www.maximintegrated.com/thermal-tutorial.

Electrical Characteristics

(V_{CC} = +3.0V to +5.5V, T_A = T_{MIN} to T_{MAX}, unless otherwise specified. Typical values are at V_{CC} = +5V and T_A = +25°C.) (Notes 2, 3)

PARAMETER	SYMBOL	CONDITIONS	MIN	TYP	MAX	UNITS
POWER SUPPLY						
Supply Voltage	V _{CC}		3.0		5.5	V
Supply Current	I _{CC}	DE = V _{CC} , RE = GND, no load		1.9	4	mA
Shutdown Supply Current	I _{SHDN}	DE = GND, RE = V _{CC}			10	μA
DRIVER						
Differential Driver Output	V _{OD}	V _{CC} = 4.5V, R _L = 54Ω, Figure 1	2.1			V
		V _{CC} = 3V, R _L = 100Ω, Figure 1	2.0			
		V _{CC} = 3V, R _L = 54Ω, Figure 1	1.5			
Change in Magnitude of Differential Output Voltage	ΔV _{OD}	R _L = 54Ω or 100Ω, Figure 1 (Note 4)	-0.2	0	+0.2	V
Driver Common-Mode Output Voltage	V _{OC}	R _L = 54Ω or 100Ω, Figure 1		V _{CC} / 2	3	V
Change in Magnitude of Common-Mode Voltage	ΔV _{OC}	R _L = 54Ω or 100Ω, Figure 1 (Note 4)	-0.2		+0.2	V
Single-Ended Driver Output High	V _{OH}	A or B output, I _{A or B} = -20mA	2.2			V
Single-Ended Driver Output Low	V _{OL}	A or B output, I _{A or B} = 20mA			0.8	V
Differential Output Capacitance	C _{OD}	DE = RE = V _{CC} , f = 4MHz		12		pF
Driver Short-Circuit Output Current	I _{OSTL}	0 ≤ V _{OUT} ≤ +12V, output low			250	mA
		-7V ≤ V _{OUT} ≤ V _{CC} , output high			250	

Electrical Characteristics (continued)(V_{CC} = +3.0V to +5.5V, T_A = T_{MIN} to T_{MAX}, unless otherwise specified. Typical values are at V_{CC} = +5V and T_A = +25°C.) (Notes 2, 3)

PARAMETER	SYMBOL	CONDITIONS	MIN	TYP	MAX	UNITS
RECEIVER						
Input Current	I _{A, B}	DE = GND, V _{CC} = GND or +5.5V	V _{IN} = +12V	400	1000	μA
			V _{IN} = -7V	-800	+300	
Differential Input Capacitance	C _{A, B}	Between A and B, DE = GND, f = 4MHz		12		pF
Receiver Differential Threshold Voltage	V _{TH}	-7V ≤ V _{CM} ≤ +12V	-200	-105	-10	mV
Receiver Input Hysteresis	ΔV _{TH}	V _{CM} = 0V		10		mV
Receiver Input Resistance	R _{IN}	-7V ≤ V _{CM} ≤ +12V	12			kΩ
LOGIC INTERFACE (DI, DE, $\overline{\text{RE}}$, RO)						
Input-Voltage High	V _{IH}	DE, DI, $\overline{\text{RE}}$	2.0			V
Input-Voltage Low	V _{IL}	DE, DI, $\overline{\text{RE}}$			0.8	V
Input Hysteresis	V _{HYS}	DE, DI, $\overline{\text{RE}}$		50		mV
Input Current	I _{IN}	DE, DI, $\overline{\text{RE}}$			±1	μA
Input Impedance on First Transition		DE, $\overline{\text{RE}}$	1		10	kΩ
RO Output-Voltage High	V _{OHR0}	$\overline{\text{RE}}$ = GND, I _{RO} = -2mA, (V _A - V _B) > 200mV	V _{CC} - 1.5			V
RO Output-Voltage Low	V _{OLRO}	$\overline{\text{RE}}$ = GND, I _{RO} = 2mA, (V _A - V _B) < -200mV			0.4	V
Receiver Three-State Output Current	I _{OZR}	$\overline{\text{RE}}$ = V _{CC} , 0 ≤ V _{RO} ≤ V _{CC}			±1	μA
Receiver Output Short-Circuit Current	I _{OSR}	0 ≤ V _{RO} ≤ V _{CC}			±110	mA
PROTECTION						
Thermal-Shutdown Threshold	T _{SHDN}	Temperature rising		+160		°C
Thermal-Shutdown Hysteresis				15		°C
ESD Protection on A and B Pins		IEC 61000-4-2 Air-Gap Discharge to GND		±20		kV
		IEC 61000-4-2 Contact Discharge to GND		±12		
		Human Body Model		±35		
ESD Protection, All Other Pins		Human Body Model		±2		kV

Switching Characteristics

($V_{CC} = +3\text{V}$ to $+5.5\text{V}$, $T_A = T_{MIN}$ to T_{MAX} , unless otherwise specified. Typical values are at $V_{CC} = +5\text{V}$ and $T_A = +25^\circ\text{C}$.) (Notes 2, 3, 5)

PARAMETER	SYMBOL	CONDITIONS	MIN	TYP	MAX	UNITS
DRIVER						
Driver Propagation Delay	t_{DPLH}	$R_L = 54\Omega$, $C_L = 50\text{pF}$, Figures 2 and 3			20	ns
	t_{DPHL}				20	
Driver Differential Output Rise or Fall Time	t_{HL} , t_{LH}	$R_L = 54\Omega$, $C_L = 50\text{pF}$, Figures 2 and 3	200		600	ns
Differential Driver Output Skew $ t_{DPLH} - t_{DPHL} $	t_{DSKEW}	$R_L = 54\Omega$, $C_L = 50\text{pF}$, Figures 2 and 3			140	ns
Maximum Data Rate	DR_{MAX}		500			kbps
Driver Enable to Output High	t_{DZH}	$R_L = 110\Omega$, $C_L = 50\text{pF}$, Figures 4 and 5 (Note 6)			2500	ns
Driver Enable to Output Low	t_{DZL}	$R_L = 110\Omega$, $C_L = 50\text{pF}$, Figures 4 and 5 (Note 6)			2500	ns
Driver Disable Time from Low	t_{DLZ}	$R_L = 110\Omega$, $C_L = 50\text{pF}$, Figures 4 and 5			100	ns
Driver Disable Time from High	t_{DHZ}	$R_L = 110\Omega$, $C_L = 50\text{pF}$, Figures 4 and 5			100	ns
Driver Enable from Shutdown to Output High	$t_{DLZ(SHDN)}$	$R_L = 110\Omega$, $C_L = 15\text{pF}$, Figures 4 and 5 (Note 6)			5.5	μs

Switching Characteristics MAX14782E (continued)

($V_{CC} = +3\text{V}$ to $+5.5\text{V}$, $T_A = T_{MIN}$ to T_{MAX} , unless otherwise specified. Typical values are at $V_{CC} = +5\text{V}$ and $T_A = +25^\circ\text{C}$.) (Notes 2, 3, 5)

PARAMETER	SYMBOL	CONDITIONS	MIN	TYP	MAX	UNITS
Driver Enable from Shutdown to Output Low	$t_{DHZ(SHDN)}$	$R_L = 110\Omega$, $C_L = 15\text{pF}$, Figures 4 and 5 (Note 6)			5.5	μs
Time to Shutdown	t_{SHDN}	(Note 7)	50	340	700	ns
RECEIVER						
Receiver Propagation Delay	t_{RPLH}	$C_L = 15\text{pF}$, Figures 6 and 7			200	ns
	t_{RPHL}				200	
Receiver Output Skew	t_{RSKEW}	$C_L = 15\text{pF}$, Figures 6 and 7 (Note 6)			30	ns
Maximum Data Rate	DR_{MAX}		500			kbps
Receiver Enable to Output High	t_{RZH}	$R_L = 1\text{k}\Omega$, $C_L = 15\text{pF}$, Figure 8 (Note 6)			50	ns
Receiver Enable to Output Low	t_{RZL}	$R_L = 1\text{k}\Omega$, $C_L = 15\text{pF}$, Figure 8 (Note 6)			50	ns
Receiver Disable Time from Low	t_{RLZ}	$R_L = 1\text{k}\Omega$, $C_L = 15\text{pF}$, Figure 8			50	ns
Receiver Disable Time from High	t_{RHZ}	$R_L = 1\text{k}\Omega$, $C_L = 15\text{pF}$, Figure 8			50	ns
Receiver Enable from Shutdown to Output High	$t_{RLZ(SHDN)}$	$R_L = 1\text{k}\Omega$, $C_L = 15\text{pF}$, Figure 8 (Note 6)			5.5	μs
Receiver Enable from Shutdown to Output Low	$t_{RHZ(SHDN)}$	$R_L = 1\text{k}\Omega$, $C_L = 15\text{pF}$, Figure 8 (Note 6)			5.5	μs
Time to Shutdown	t_{SHDN}	(Note 7)	50	340	700	ns

Note 2: All devices 100% production tested at $T_A = +25^\circ\text{C}$. Specifications over temperature are guaranteed by design.

Note 3: All currents into the device are positive; all currents out of the device are negative. All voltages are referenced to ground, unless otherwise noted.

Note 4: ΔV_{OD} and ΔV_{OC} are the changes in V_{OD} and V_{OC} , respectively, when the DI input changes state.

Note 5: Capacitive load includes test probe and fixture capacitance.

Note 6: Guaranteed by design; not production tested.

Note 7: The timing parameter refers to the driver or receiver enable delay, when the device has exited the initial hot-swap protect state and is in normal operating mode.

Test and Timing Diagrams

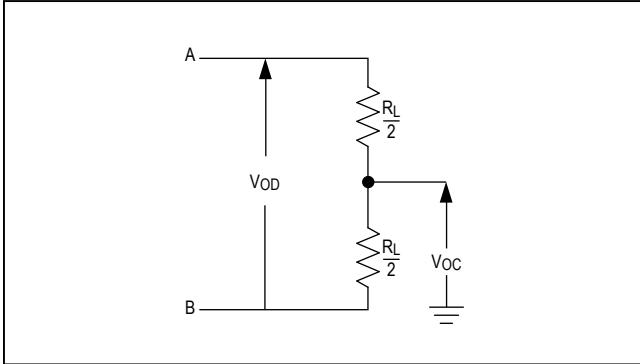

Figure 1. Driver DC Test Load

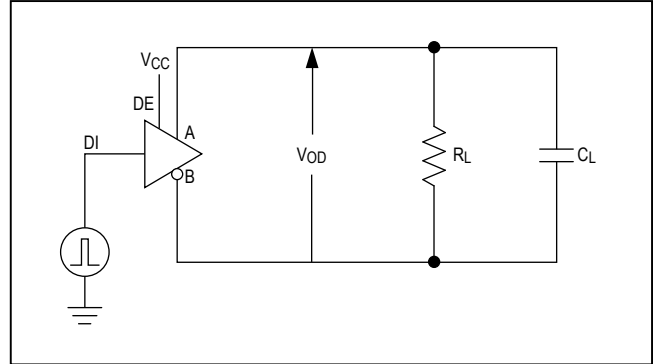

Figure 2. Driver Timing Test Circuit

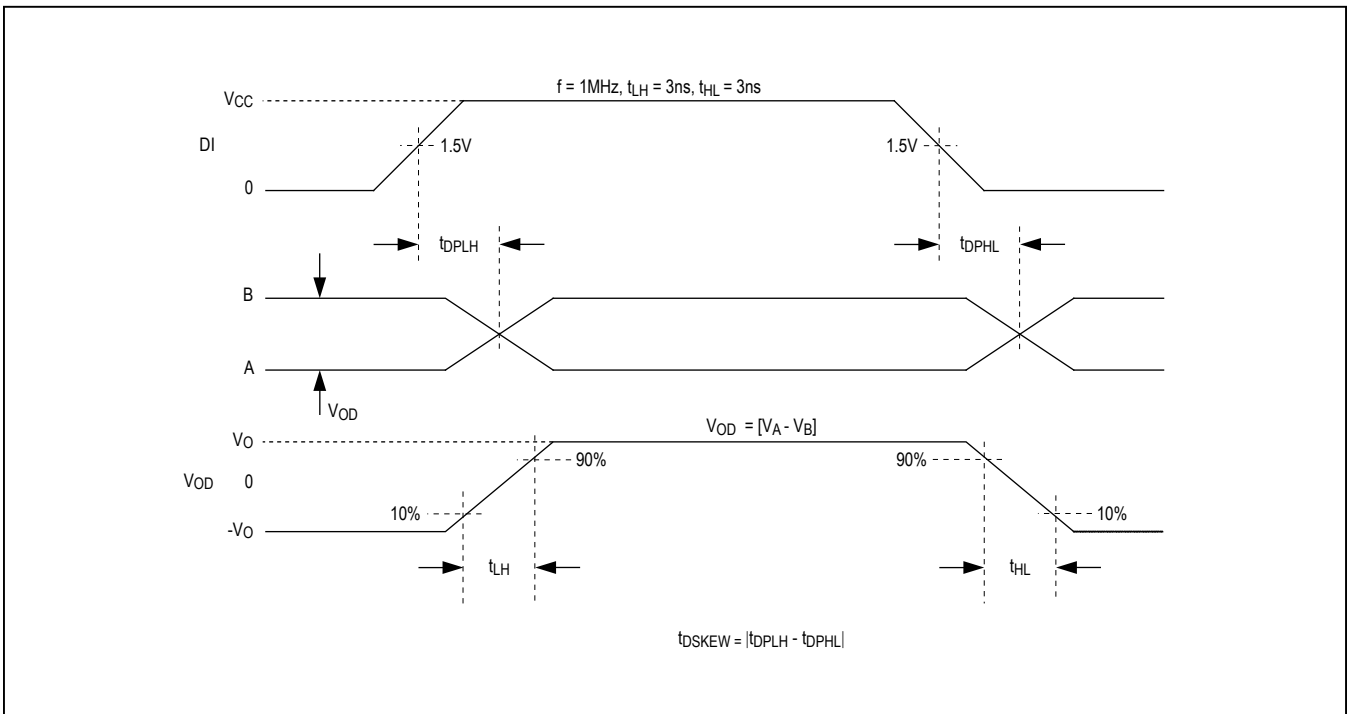

Figure 3. Driver Propagation Delays

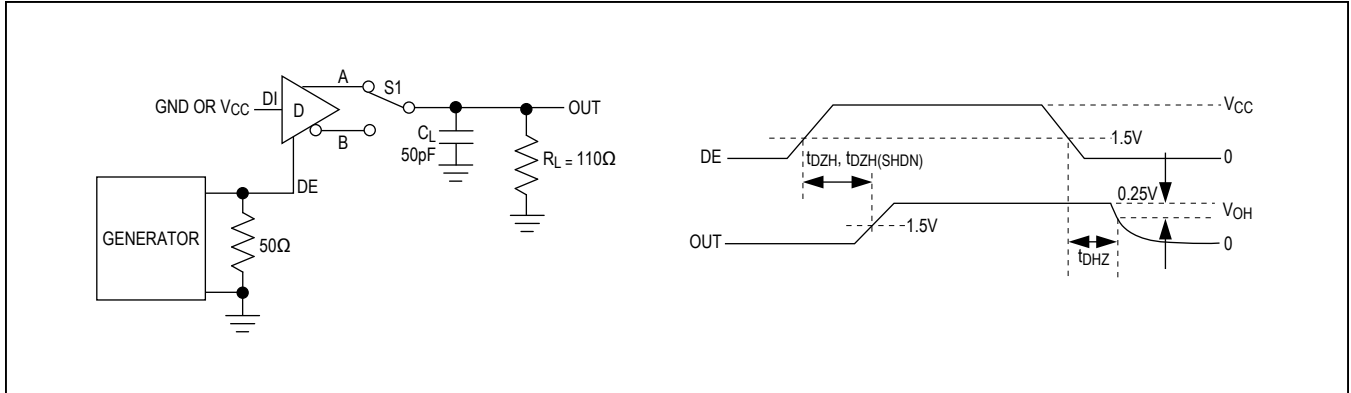

Figure 4. Driver Enable and Disable Times (t_{DZH} , t_{DZH})

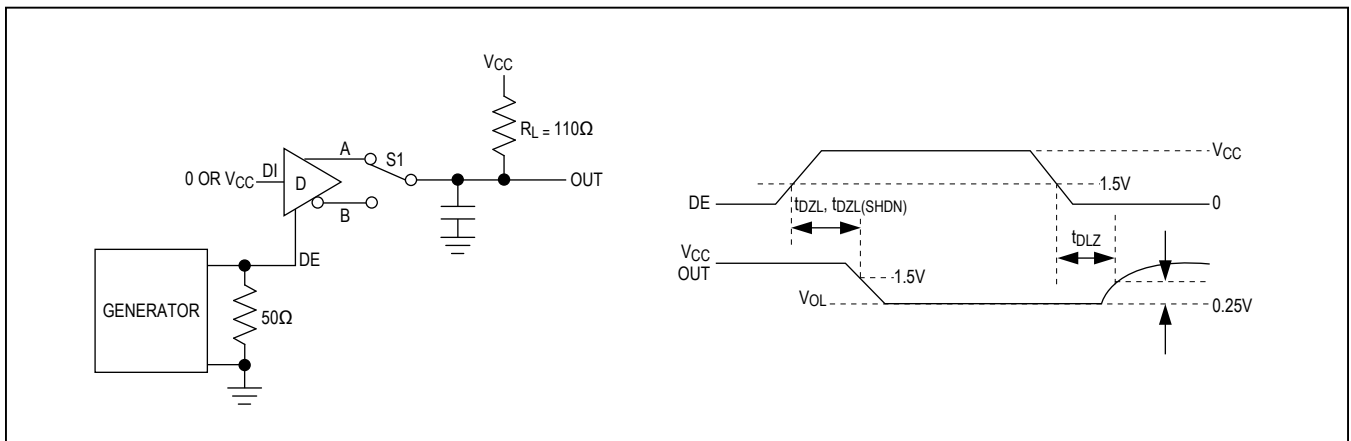

Figure 5. Driver Enable and Disable Times (t_{DZL} , t_{DZL})

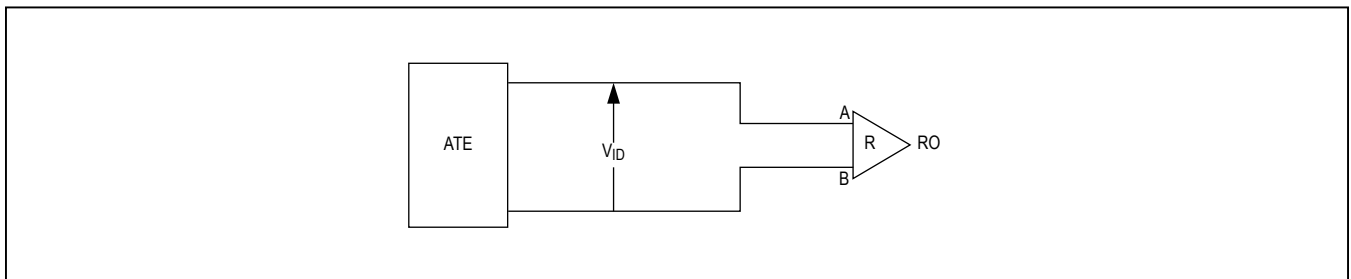

Figure 6. Receiver Propagation Delay Test Circuit

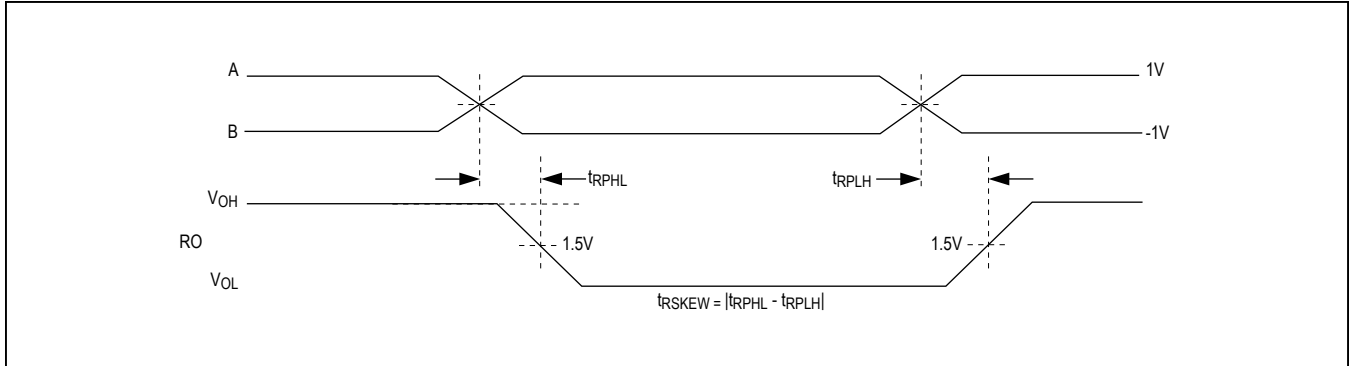

Figure 7. Receiver Propagation Delays

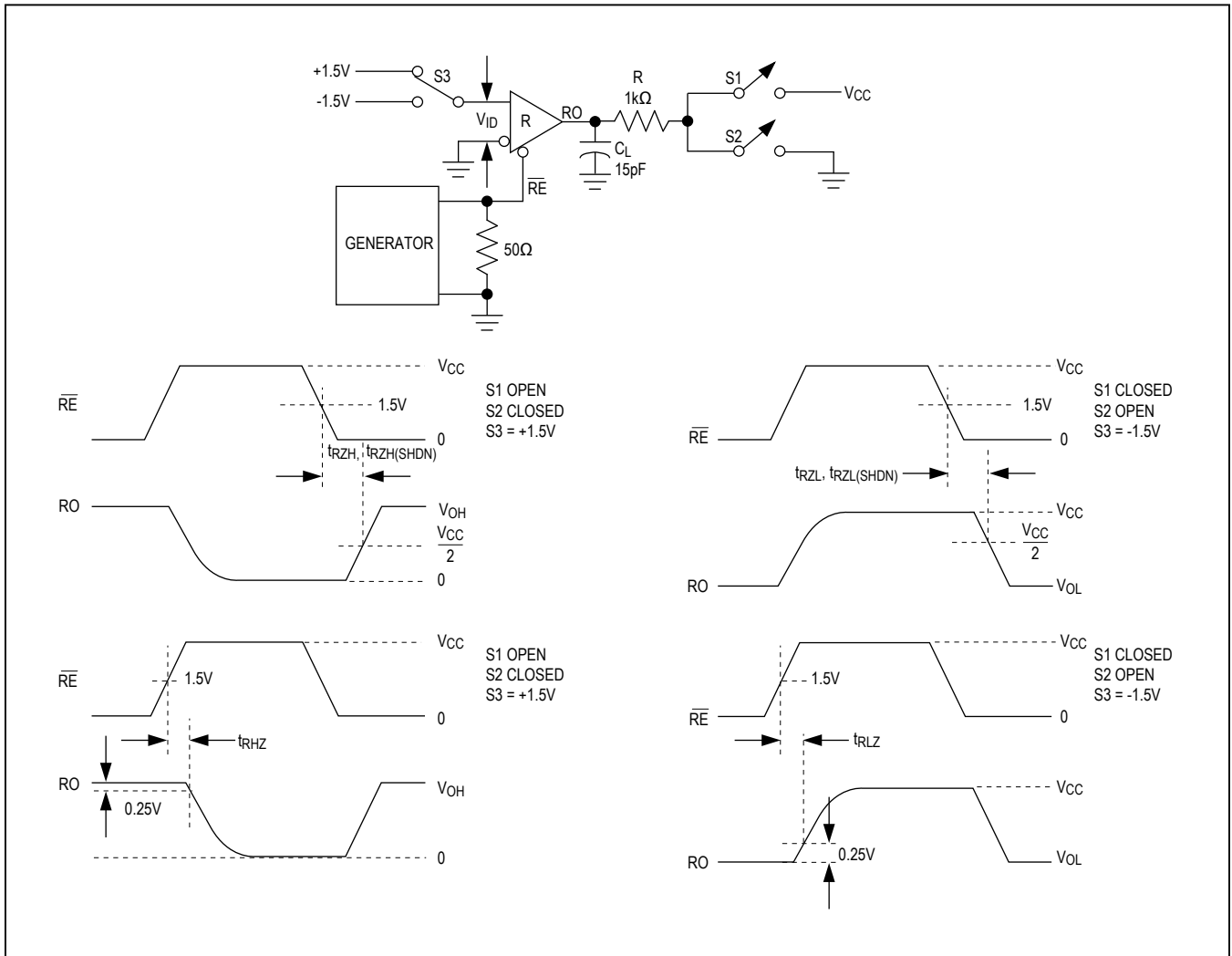
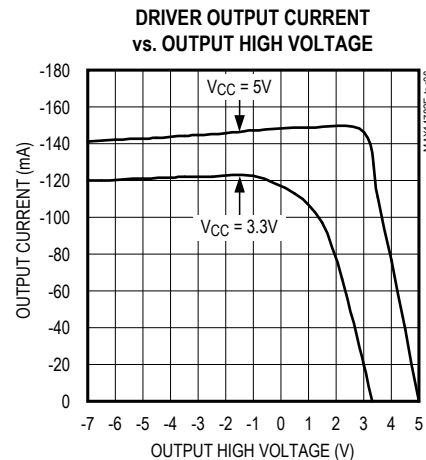
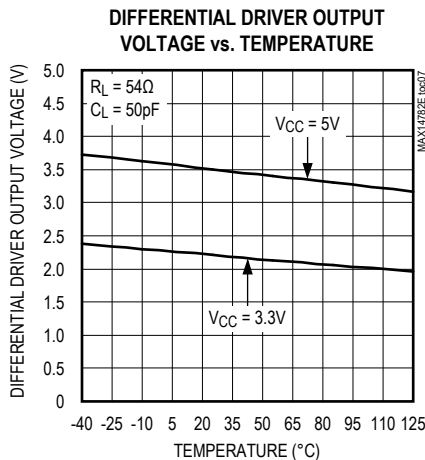
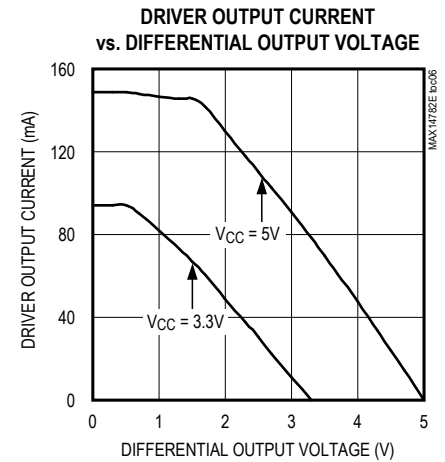
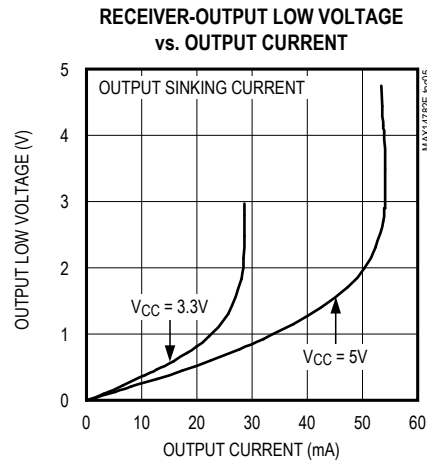
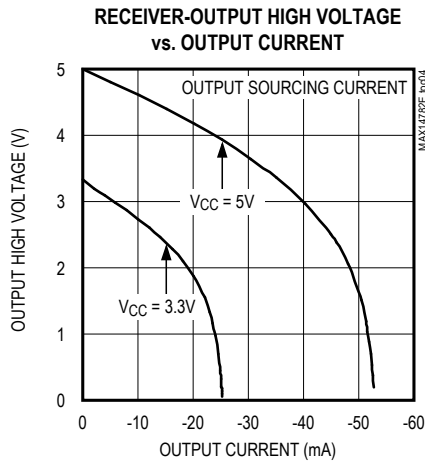
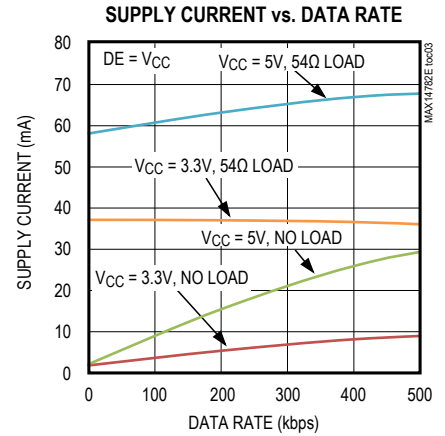
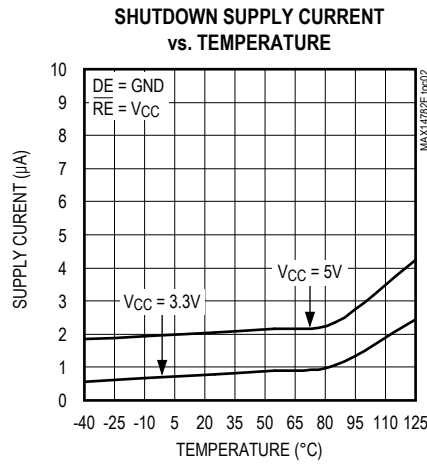
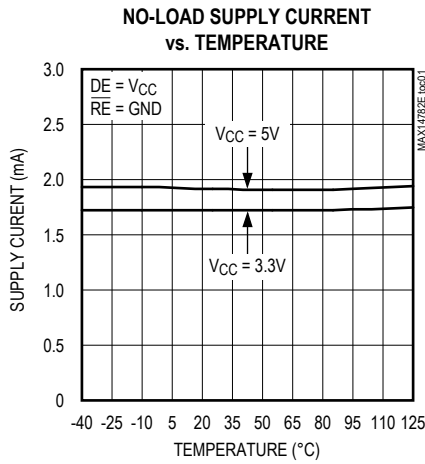

Figure 8. Receiver Enable and Disable Times

Typical Operating Characteristics

($V_{CC} = +5\text{V}$, $T_A = +25^\circ\text{C}$, unless otherwise specified.)



Typical Operating Characteristics (continued)

(V_{CC} = +5V, T_A = +25°C, unless otherwise specified.)

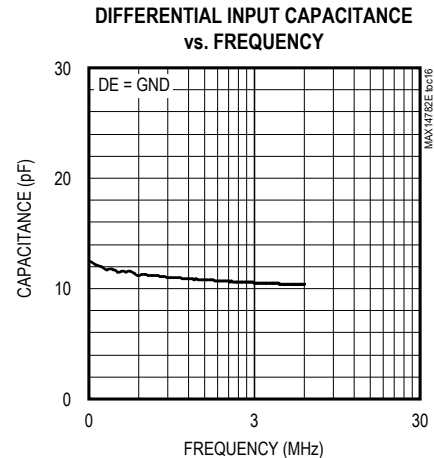
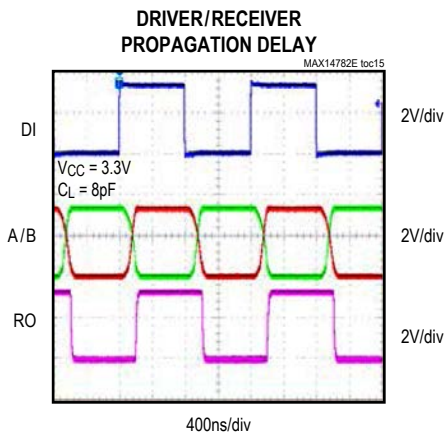
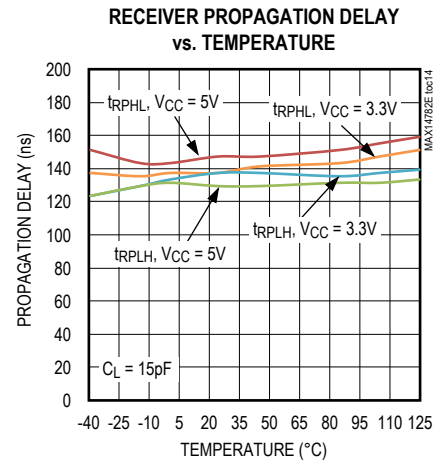
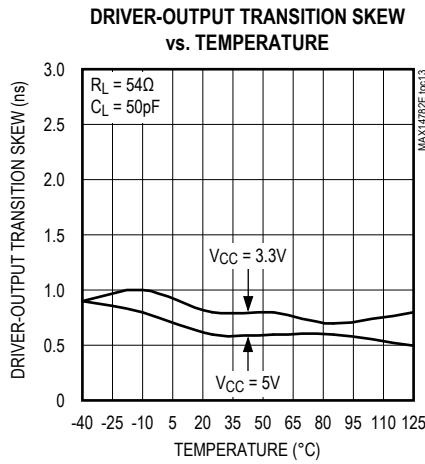
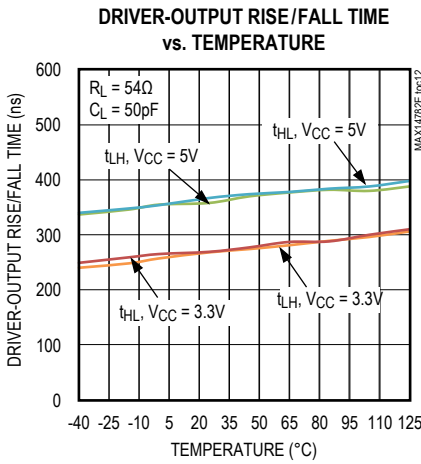
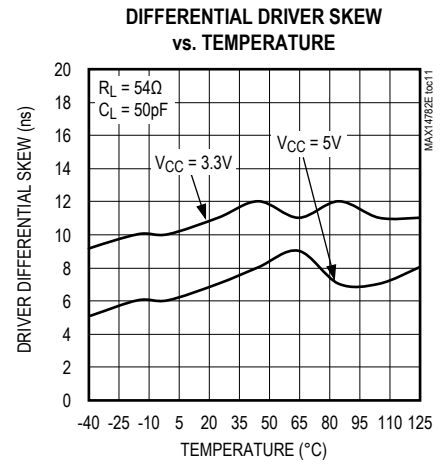
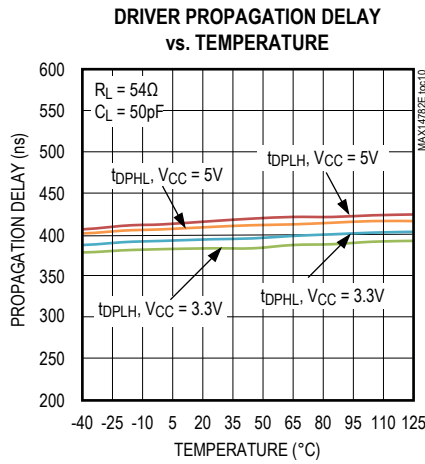
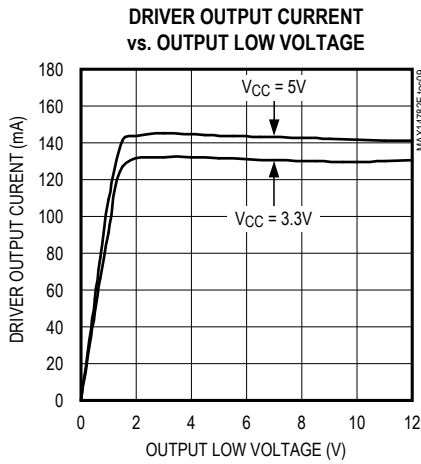

Pin Configuration

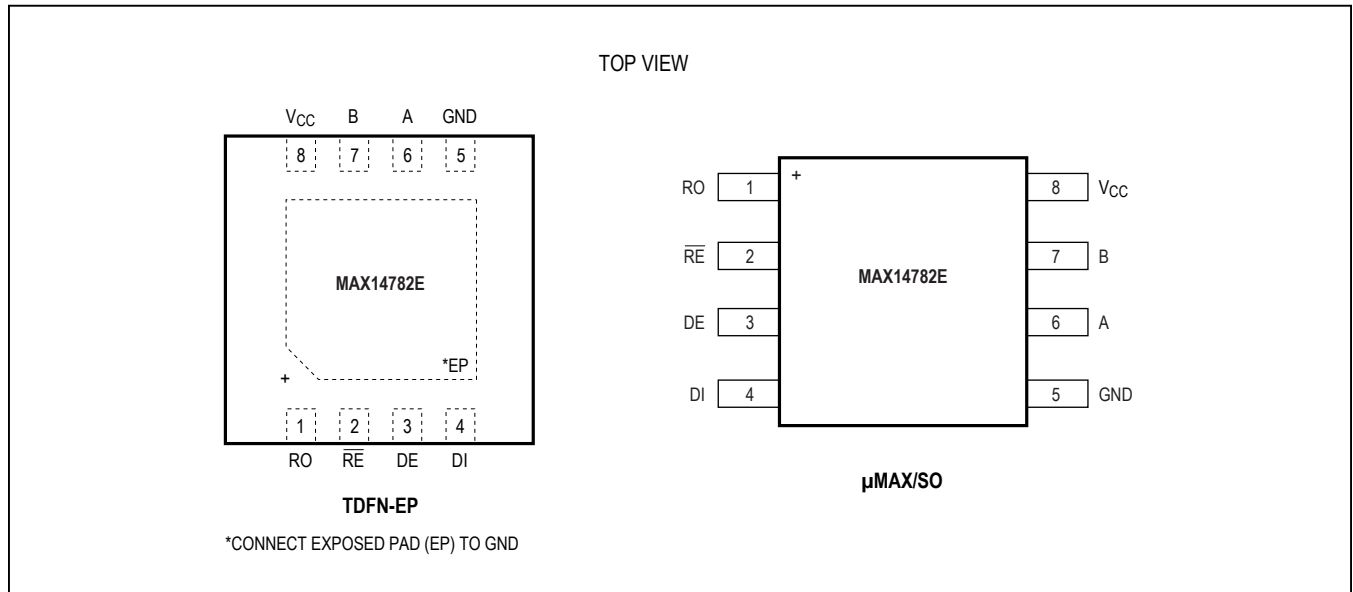

Pin Description

PIN	NAME	FUNCTION
1	RO	Receiver Output. See <i>Function Tables</i> .
2	\overline{RE}	Receiver Output Enable. Drive \overline{RE} low to enable RO. Drive \overline{RE} high to disable the receiver. RO is high impedance when \overline{RE} is high. Drive \overline{RE} high and pull DE low to enter low-power shutdown mode.
3	DE	Driver Output Enable. Drive DE high to enable the driver. Drive DE low to disable the driver. Driver outputs are high-impedance when the driver is disabled. Drive \overline{RE} high and pull DE low to enter low-power shutdown mode.
4	DI	Driver Input. With DE high, a low on DI forces the A output low and the B output high. Similarly, a high on DI forces the A output high and B output low.
5	GND	Ground
6	A	Noninverting RS-485/RS-422 Receiver Input and Driver Output
7	B	Inverting RS-485/RS-422 Receiver Input and Driver Output
8	V _{CC}	Positive Supply Voltage Input. Bypass V _{CC} with a 0.1μF ceramic capacitor to ground.
—	EP	Exposed Pad (TDFN only). Connect EP to GND.

Function Tables

TRANSMITTING					
INPUTS			OUTPUTS		MODE
\overline{RE}	DE	DI	B	A	
X	1	1	0	1	Active
X	1	0	1	0	Active
0	0	X	High Impedance		Driver Disabled
1	0	X	High Impedance		Shutdown

RECEIVING					
INPUTS			OUTPUTS	MODE	
\overline{RE}	DE	A-B	RO		
0	X	$\geq -10mV$	1	Active	
0	X	$\leq -200mV$	0	Active	
0	X	Open/Shorted	1	Active	
1	1	X	High Impedance		Receiver Disabled
1	0	X	High Impedance		Shutdown

X = Don't care

Functional Diagram

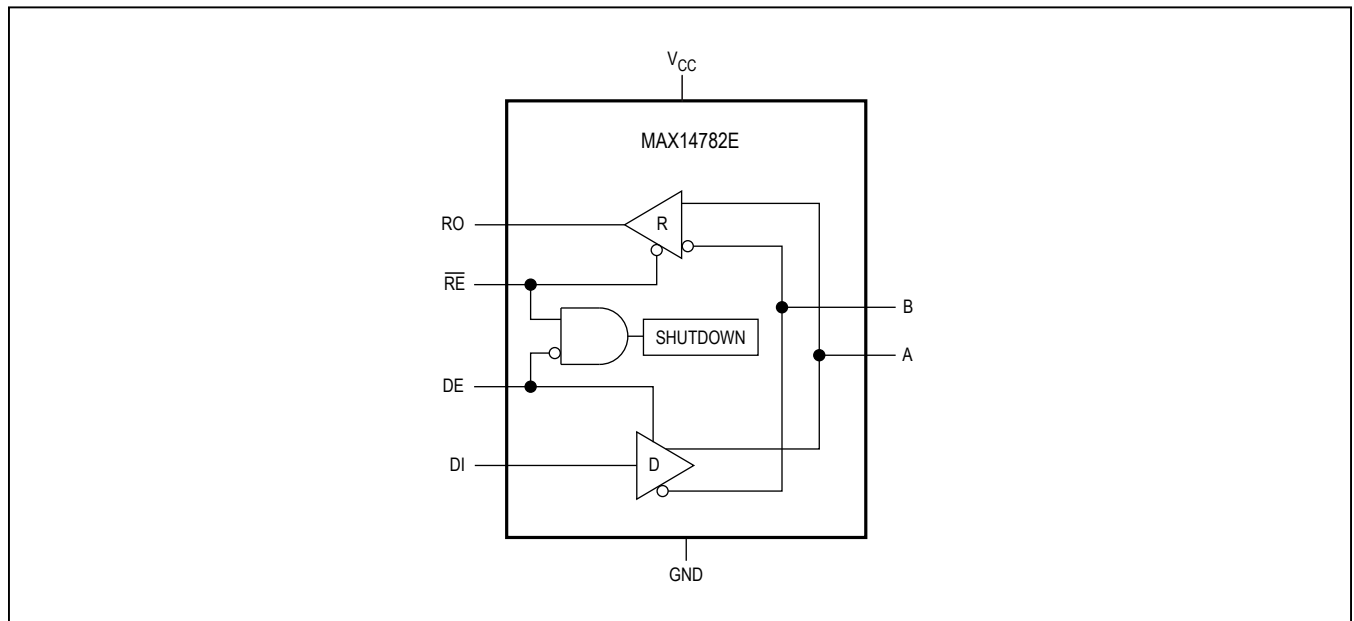

Detailed Description

The MAX14782E is a 3.3V to 5V ESD-protected RS-485/RS-422 transceiver intended for high-speed, half-duplex communications. Integrated hot-swap functionality eliminates false transitions on the bus during power-up or hot insertion.

The device features fail-safe receiver inputs guaranteeing a logic-high receiver output when inputs are shorted or open. The IC has a 1-unit load receiver input impedance, allowing up to 32 transceivers on the bus.

True Fail Safe

The MAX14782E guarantees a logic-high receiver output when the receiver inputs are shorted or open, or when they are connected to a terminated transmission line with all drivers disabled. If the differential receiver input voltage (A-B) is greater than or equal to -10mV , RO is logic-high.

Driver Single-Ended Operation

The A and B outputs can either be used in the standard differential operating mode, or can be used as single-ended outputs. Since the A and B driver outputs swing rail-to-rail, they can individually be used as standard TTL logic outputs.

Hot-Swap Capability

Hot-Swap Inputs

When circuit boards are inserted in a hot or powered backplane, disturbances on the enable inputs and differential receiver inputs can lead to data errors. Upon initial circuit board insertion, the processor undergoes its power-up sequence. During this period, the processor output drivers are high impedance and are unable to drive the DE and $\overline{\text{RE}}$ inputs of the MAX14782E to a defined logic level. Leakage currents up to $10\mu\text{A}$ from the high-impedance outputs of a controller could cause DE and $\overline{\text{RE}}$ to drift to an incorrect logic state. Additionally, parasitic circuit board capacitance could cause coupling of V_{CC} or GND to DE and $\overline{\text{RE}}$. These factors could improperly enable the driver or receiver. The MAX14782E features integrated hot-swap inputs that help to avoid these potential problems.

When V_{CC} rises, an internal pulldown circuit holds DE low and $\overline{\text{RE}}$ high. After the initial power-up sequence, the pulldown circuit becomes transparent, resetting the hot-swap-tolerable inputs.

Hot-Swap Input Circuitry

The DE and $\overline{\text{RE}}$ enable inputs feature hot-swap capability. At the input, there are two nMOS devices, M1 and M2 (Figure 9). When V_{CC} ramps from 0V, an internal $10\mu\text{s}$ timer turns on M2 and sets the SR latch that also turns

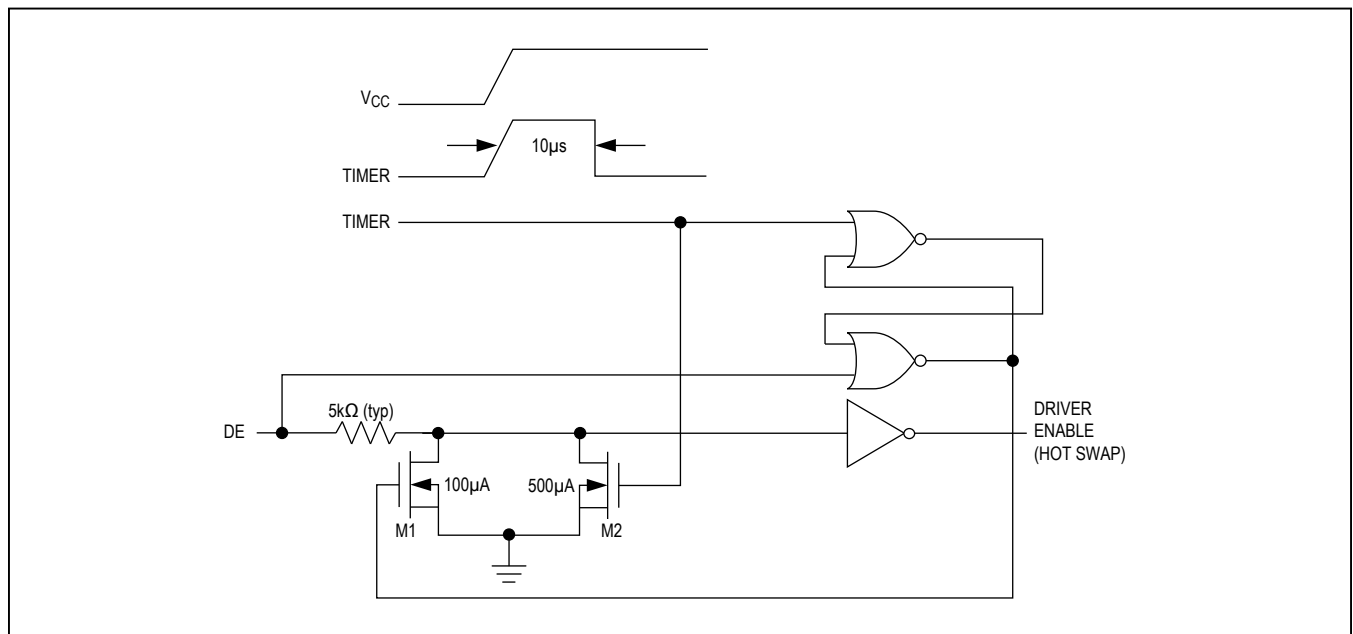

Figure 9. Simplified Structure of the Driver Enable (DE) Pin

on M1. Transistors M2 (a 500µA current sink) and M1 (a 100µA current sink) pull DE to GND through a 5kΩ (typ) resistor. M2 is designed to pull DE to the disabled state against an external parasitic capacitance up to 100pF that can drive DE high. After 10µs, the timer deactivates M2 while M1 remains on, holding DE low against three-state leakages that can drive DE high. M1 remains on until an external source overcomes the required input current. At this time, the SR latch resets and M1 turns off. When M1 turns off, DE reverts to a standard, high-impedance CMOS input. Whenever V_{CC} drops below 1V, the hot-swap input is reset.

A complementary circuit employing two pMOS devices pulls RE to V_{CC}.

±35kV ESD Protection

ESD protection structures are incorporated on all pins to protect against electrostatic discharges encountered during handling and assembly. The driver outputs and receiver inputs of the MAX14782E have extra protection against static electricity. The ESD structures withstand high ESD in all states: normal operation, shutdown, and powered down. After an ESD event, the MAX14782E keeps working without latch-up or damage.

ESD protection can be tested in various ways. The transmitter outputs and receiver inputs of the MAX14782E are characterized for protection to the following limits:

- ±35kV HBM
- ±20kV using the Air-Gap Discharge method specified in IEC 61000-4-2
- ±12kV using the Contact Discharge method specified in IEC 61000-4-2

ESD Test Conditions

ESD performance depends on a variety of conditions. Contact Maxim for a reliability report that documents test setup, test methodology, and test results.

Human Body Model (HBM)

Figure 10 shows the HBM, and Figure 11 shows the current waveform it generates when discharged into a low-impedance state. This model consists of a 100pF capacitor charged to the ESD voltage of interest, which is then discharged into the test device through a 1.5kΩ resistor.

IEC 61000-4-2

The IEC 61000-4-2 standard covers ESD testing and performance of finished equipment. However, it does not specifically refer to integrated circuits. The MAX14782E helps in designing equipment to meet IEC 61000-4-2 without the need for additional ESD protection components.

The major difference between tests done using the HBM and IEC 61000-4-2 is higher peak current in IEC 61000-4-2 because series resistance is lower in the IEC 61000-4-2 model. Hence, the ESD withstand voltage measured to IEC 61000-4-2 is generally lower than that measured using the HBM.

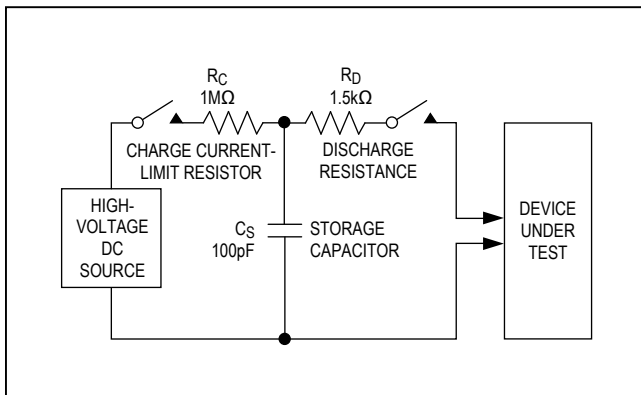

Figure 10. Human Body ESD Test Model

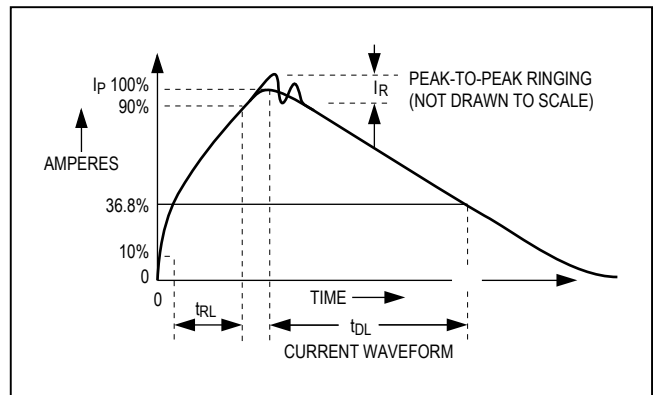

Figure 11. Human Body Current Waveform

Figure 12 shows the IEC 61000-4-2 model, and Figure 13 shows the current waveform for IEC 61000-4-2 ESD Contact Discharge test.

Applications Information

Driver Output Protection

Two mechanisms prevent excessive output current and power dissipation caused by faults or by bus connection. The first, a current limit on the output stage provides immediate protection against short circuits over the whole common-mode voltage range. The second, a thermal-shutdown circuit, forces the driver outputs into a high-impedance state if the die temperature exceeds +160°C (typ).

Low-Power Shutdown Mode

Low-power shutdown mode is initiated by bringing \overline{RE} high and DE low. In shutdown, the devices draw less than 10µA of supply current.

\overline{RE} and DE can be connected together and driven simultaneously. The MAX14782E is guaranteed not to enter shutdown if \overline{RE} is high and DE is low for less than 50ns. If the inputs are in this state for at least 800ns (max), the device is guaranteed to enter shutdown.

Typical Applications

The MAX14782E transceiver is designed for bidirectional data communications on multipoint bus transmission lines. Figure 14 shows a typical network application circuit. To minimize reflections, terminate the line at both ends with its characteristic impedance and keep stub lengths off the main line as short as possible.

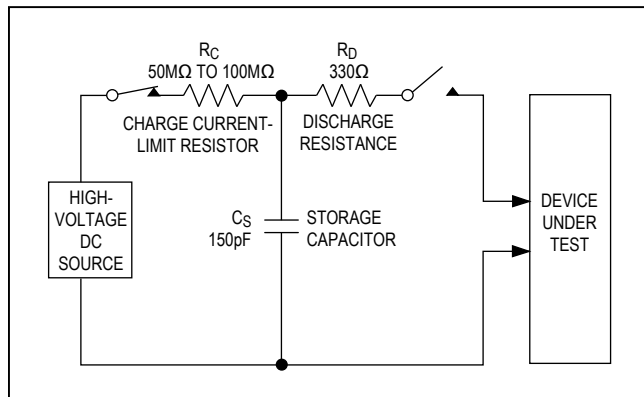

Figure 12. IEC 61000-4-2 ESD Test Model

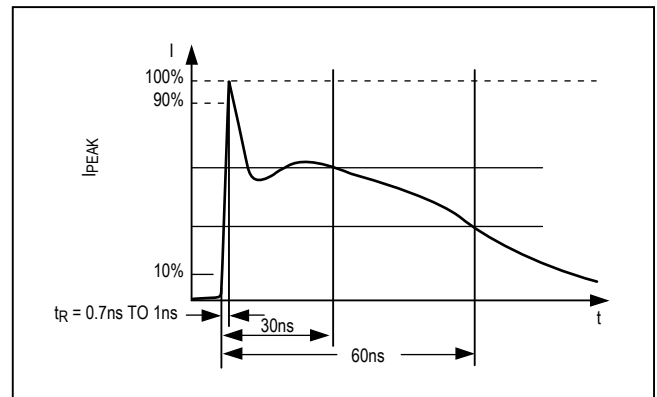

Figure 13. IEC 61000-4-2 ESD Generator Current Waveform

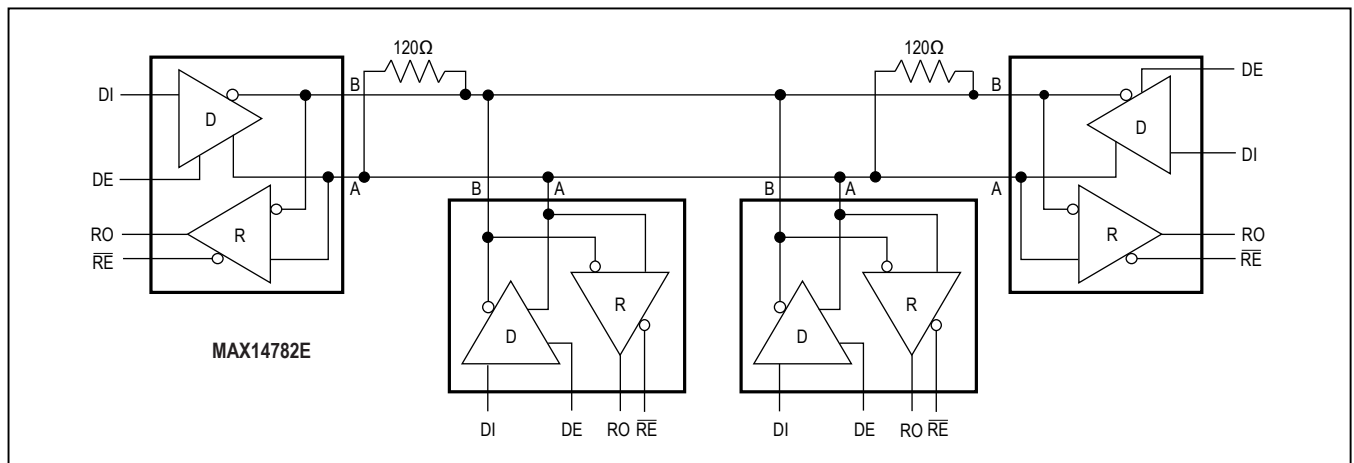

Figure 14. Typical Half-Duplex RS-485 Network

Chip Information

PROCESS: BICMOS

Package Information

For the latest package outline information and land patterns (footprints), go to www.maximintegrated.com/packages. Note that a "+", "#", or "-" in the package code indicates RoHS status only. Package drawings may show a different suffix character, but the drawing pertains to the package regardless of RoHS status.

PACKAGE TYPE	PACKAGE CODE	OUTLINE NO.	LAND PATTERN NO.
8 SO	S8+4	21-0041	90-0096
8 TDFN-EP	T833+2	21-0137	90-0059
8 μ MAX	U8+1	21-0036	90-0092

MAX14782E

500Kbps 3.3V to 5V RS-485/RS-422 Transceiver
with $\pm 35\text{kV}$ HBM ESD Protection

Revision History

REVISION NUMBER	REVISION DATE	DESCRIPTION	PAGES CHANGED
0	8/13	Initial release	—

For pricing, delivery, and ordering information, please contact Maxim Direct at 1-888-629-4642, or visit Maxim Integrated's website at www.maximintegrated.com.

Maxim Integrated cannot assume responsibility for use of any circuitry other than circuitry entirely embodied in a Maxim Integrated product. No circuit patent licenses are implied. Maxim Integrated reserves the right to change the circuitry and specifications without notice at any time. The parametric values (min and max limits) shown in the Electrical Characteristics table are guaranteed. Other parametric values quoted in this data sheet are provided for guidance.