



Chipsmall Limited consists of a professional team with an average of over 10 year of expertise in the distribution of electronic components. Based in Hongkong, we have already established firm and mutual-benefit business relationships with customers from,Europe,America and south Asia,supplying obsolete and hard-to-find components to meet their specific needs.

With the principle of “Quality Parts,Customers Priority,Honest Operation,and Considerate Service”,our business mainly focus on the distribution of electronic components. Line cards we deal with include Microchip,ALPS,ROHM,Xilinx,Pulse,ON,Everlight and Freescale. Main products comprise IC,Modules,Potentiometer,IC Socket,Relay,Connector.Our parts cover such applications as commercial,industrial, and automotives areas.

We are looking forward to setting up business relationship with you and hope to provide you with the best service and solution. Let us make a better world for our industry!



## Contact us

Tel: +86-755-8981 8866 Fax: +86-755-8427 6832

Email & Skype: info@chipsmall.com Web: www.chipsmall.com

Address: A1208, Overseas Decoration Building, #122 Zhenhua RD., Futian, Shenzhen, China



## General Description

The MAX14970 evaluation kit (EV kit) provides a proven design to evaluate the MAX14970 dual-channel buffer. The EV kit contains four sections: an application circuit, characterization circuit, and two sets of calibration traces.

The application circuit is designed to demonstrate the device's use in redriving serial-ATA (SATA) signals and SATA cable detection. This section of the EV kit operates from an external +5V supply that is regulated by an on-board LDO to +3.3V, which powers the device. All traces in the application circuit are 100Ω differential controlled-impedance traces.

The characterization circuit is provided for eye diagram evaluation using SMA connectors and 50Ω controlled-impedance traces. This section is powered by an external +3.3V power supply.

## Features

- Application Circuit with SATA Input/Output
- Eye Diagram Test Circuit with SMA Inputs/Outputs
- Calibration Traces (50Ω Load Trace and Through Trace)
- Proven PCB Layout
- Fully Assembled and Tested

**Ordering Information** appears at end of data sheet.

## Quick Start (Application Circuit)

### Recommended Equipment

- MAX14970 EV kit
- +5V power supply
- Two SATA cables
- SATA device (e.g., a hard drive)
- SATA host (e.g., a PC)

### Procedure

The MAX14970 EV kit is fully assembled and tested. Follow the steps below to verify board operation:

- 1) Verify that all jumpers are in their default position, as shown in Table 1.
- 2) Connect the first SATA cable from the PC to the host (J1) connector on the EV kit.
- 3) Connect the second SATA cable from the device (J2) connector to the SATA device.
- 4) Verify communication between the host PC and SATA device.

**Table 1. Default Shunt Positions**

JUMPER	SHUNT POSITION
JU1, JU5	1-2
JU2, JU3, JU7, JU8, JU9	2-3
JU4	Installed

### Detailed Description of Hardware

The MAX14970 evaluation kit (EV kit) evaluates the MAX14970 dual-channel buffer. The device is designed to redrive SATA and eSATA signals. The EV kit is divided into four sections: application circuit, characterization circuit, and two sets of calibration traces.

The application circuit utilizes 100Ω differential controlled-impedance traces and provides two SATA connectors (J1 and J2), allowing for evaluation of the device in a SATA environment. The characterization circuit utilizes 50Ω controlled-impedance traces and SMA input/output connectors, allowing for eye diagrams, and input/output return-loss measurements.

The lower half of the EV kit provides two sets of calibration traces, all of which are matched to the trace lengths in the characterization circuit. These traces provide a reference for determining the performance of only the device when evaluated in the characterization circuit.

The device has a cable-detect feature (CAD).

#### Application Circuit (U1)

The application circuit provides the means for evaluating the device in a SATA application. This section of the EV kit provides two SATA connectors (J1 and J2), one for connection to a SATA host (e.g., a PC), and the other for connection to a SATA device (e.g., a hard drive).

#### Input Supply (VIN)

The application circuit must be powered by +3.3V. There are two ways to get this voltage, either from the on-board LDO linear regulator (U3), or directly connected to a +3.3V power supply. When using the on-board voltage regulator, the LDO can be powered by the 4-pin Molex connector (H1), or by a +5V external supply connected to the VIN and GND PCB pads. When using the on-board LDO linear regulator to supply power, there is a power LED (D1) to indicate the presence of +3.3V at VCC.

The user can also connect directly to a +3.3V supply, which is available on a SATA power connector. The shunt should be removed from jumper JU4 and a wire connected from the SATA power pin to pin 2 (right-most pin) of jumper JU4 (see Table 2).

#### Device Enable (JU1)

The application circuit is enabled/disabled by configuring jumper JU1 (see Table 3). When disabled the device buffers are powered down and the part is placed in a low-power mode. When enabled and no SATA device is plugged in (CAD is unconnected), the device enters a low-power mode. Once a SATA device is plugged in (CAD grounded) the device goes into active mode.

**Table 2. Jumper JU4 Function**

SHUNT POSITION	VCC PIN (U1)	DESCRIPTION
Installed*	Connected to the on-board LDO linear regulator output	U1 powered by the LDO linear regulator output (+3.3V)
Not installed	Connected to an external supply	Powered by +3.3V from an external supply or SATA power connector

\*Default configuration.

**Table 3. Jumper JU1 Function (U1 EN)**

SHUNT POSITION	EN PIN (U1)	DESCRIPTION
1-2*	Connected to +3.3V	Buffers enabled for normal operation
2-3	Connected to GND	Buffers disabled and the device is in low-power mode

\*Default configuration.

**Output Preemphasis (JU2, JU3)**

The host and device can be evaluated with or without output preemphasis. Configure JU2 to enable/disable the host output (HAP, HAM) preemphasis and JU3 to enable/disable the device output (DBM, DBP) preemphasis (see Tables 4 and 5).

**Out-of-Band (OOB) Mode Selection (JU8)**

The application circuit provides full OOB signal support through high-speed OOB-detection circuitry. The SATA range used can be selected through configuration of jumper JU8 (see Table 6). When the MODE pin is set to GND, the SATA version 3.0 range is used. When the MODE pin is set to +3.3V, the SATA version 2.6 range is used.

**Table 4. Jumper JU2 Function (U1 PB)**

SHUNT POSITION	PB PIN (U1)	DESCRIPTION
1-2	Connected to +3.3V	Host output preemphasis enabled
2-3*	Connected to GND	Host output preemphasis disabled
Not installed	Not connected	

\*Default configuration.

**Table 5. Jumper JU3 Function (U1 PA)**

SHUNT POSITION	PA PIN (U1)	DESCRIPTION
1-2	Connected to +3.3V	Device output preemphasis enabled
2-3*	Connected to GND	Device output preemphasis disabled
Not installed	Not connected	

\*Default configuration.

**Characterization Circuit (U2)**

The characterization circuit is provided as a separate test circuit for eye diagram evaluation of the device. This circuit provides differential SMA inputs and outputs with 50Ω controlled-impedance traces. Channel B is not utilized in this section of the EV kit, but provides the same performance as channel A.

**Input Supply (VCC)**

The characterization circuit is powered by an external +3.3V power supply connected between the VCC and GND PCB pads.

**Device Enable (JU5)**

The characterization circuit is enabled/disabled by configuring jumper JU5 (see Table 7). When disabled, the device buffers are powered down and the part is placed in a low-power mode.

**Table 6. Jumper JU8 Function (U1 MODE)**

SHUNT POSITION	MODE PIN (U1)	DESCRIPTION
1-2	Connected to +3.3V	SATA version 2.6 range is used
2-3*	Connected to GND	SATA version 3.0 range is used

\*Default configuration.

**Table 7. Jumper JU5 Function (U2 EN)**

SHUNT POSITION	EN PIN (U2)	DESCRIPTION
1-2*	Connected to +3.3V	Buffers enabled for normal operation
2-3	Connected to GND	Buffers disabled and the device is in low-power standby mode

\*Default configuration.

**Output Preemphasis (JU7)**

The characterization circuit channel A can be evaluated with or without output preemphasis. Configure JU7 of the characterization circuit channel A to enable/disable output preemphasis (See Table 8).

**OOB Mode Selection (JU9)**

The characterization circuit provides full OOB signal support through high-speed OOB-detection circuitry. The SATA range used can be selected through configuration of jumper JU8 (see Table 9). When the MODE pin is set to GND, the SATA version 3.0 range is used. When the MODE pin is set to VCC, the SATA version 2.6 range is used.

**Table 8. Jumper JU7 Function (U2 PA)**

SHUNT POSITION	PA PIN (U2)	DESCRIPTION
1-2	Connected to +3.3V	Channel A output preemphasis enabled
2-3*	Connected to GND	Channel A output preemphasis disabled
Not installed	Not connected	

\*Default configuration.

**Calibration Traces**

The bottom half of the EV kit provides two sets of calibration traces that can be used for further analysis. The lengths of the calibration traces are matched to the traces going from the SMA connector to the characterization circuit. The first calibration trace includes a 50Ω load termination and the second calibration trace is a through trace.

**Table 9. Jumper JU8 Function (U2 MODE)**

SHUNT POSITION	MODE PIN (U2)	DESCRIPTION
1-2	Connected to VCC	SATA version 2.6 range is used
2-3*	Connected to GND	SATA version 3.0 range is used

\*Default configuration.

### Component List

DESIGNATION	QTY	DESCRIPTION
C1–C8, C14–C17, C22–C25	16	0.01µF ±10%, 25V X7R ceramic capacitors (0402) Murata GRM155R71E103KA TDK C1005X7R1E103K
C9, C18, C26, C27	4	1µF ±10%, 16V X7R ceramic capacitors (0603) Murata GRM188R71C105K TDK C1608X7R1C105K
C10–C13, C19, C20, C21	7	0.1µF ±10%, 16V X7R ceramic capacitors (0402) Murata GRM155R71C104K TDK C1005X7R1C104K
C28	1	4.7µF ±10%, 10V X7R ceramic capacitor (0805) Murata GRM21BR71A475K
D1	1	Green LED (0603)
H1	1	Disk-drive power connector
J1, J2	2	7-position SATA vertical connectors
JU1, JU2, JU3, JU5, JU7, JU8, JU9	7	3-pin headers, 0.1in centers

DESIGNATION	QTY	DESCRIPTION
JU4	1	2-pin header, 0.1in center
JU6	0	Not installed, 3-pin header
P1–P10	10	Edge-mount receptacle SMA connectors
R1	1	200Ω ±5% resistor (0603)
R2, R3	2	49.9Ω ±1% resistors (0603)
R4, R5, R6	0	Not installed, resistors (0603)
R7, R8	0	Not installed, resistors (0402)
U1, U2	2	SATA/eSATA bidirectional redrivers (20 TQFN-EP) Maxim MAX14970ETP+
U3	1	3.3V LDO linear regulator (6 SOT23) Maxim MAX6329TPUT-T+ (Top Mark: AAIP)
—	8	Shunts
—	1	PCB: MAX14970 EVALUATION KIT

### Component Suppliers

SUPPLIER	PHONE	WEBSITE
Murata Electronics North America, Inc.	770-436-1300	www.murata-northamerica.com
TDK Corp.	847-803-6100	www.component.tdk.com

**Note:** Indicate that you are using the MAX14970 when contacting these component suppliers.

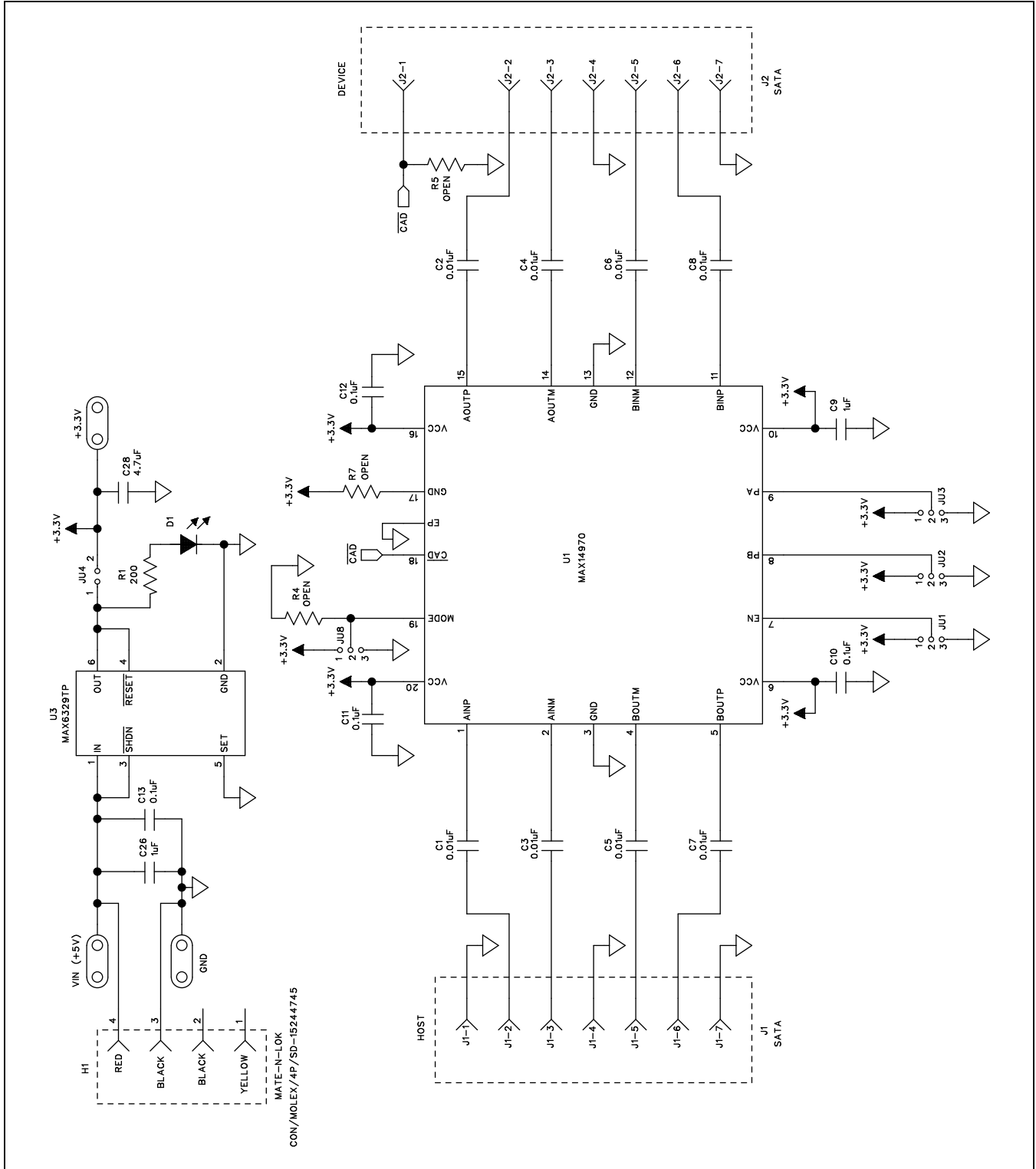

Figure 1a. MAX14970 EV Kit Schematic—Application Circuit (Sheet 1 of 3)

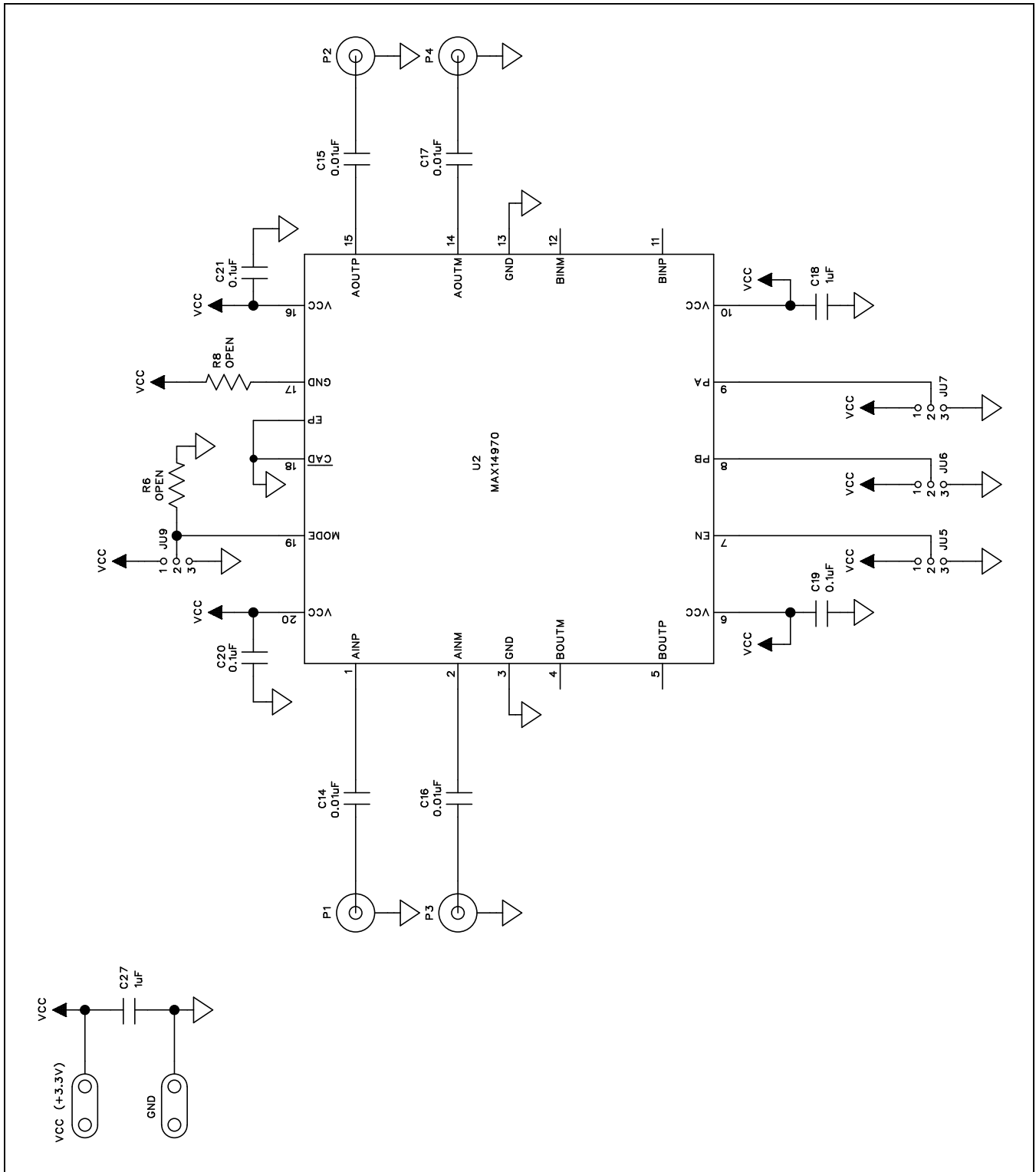

Figure 1b. MAX14970 EV Kit Schematic—Characterization Circuit (Sheet 2 of 3)



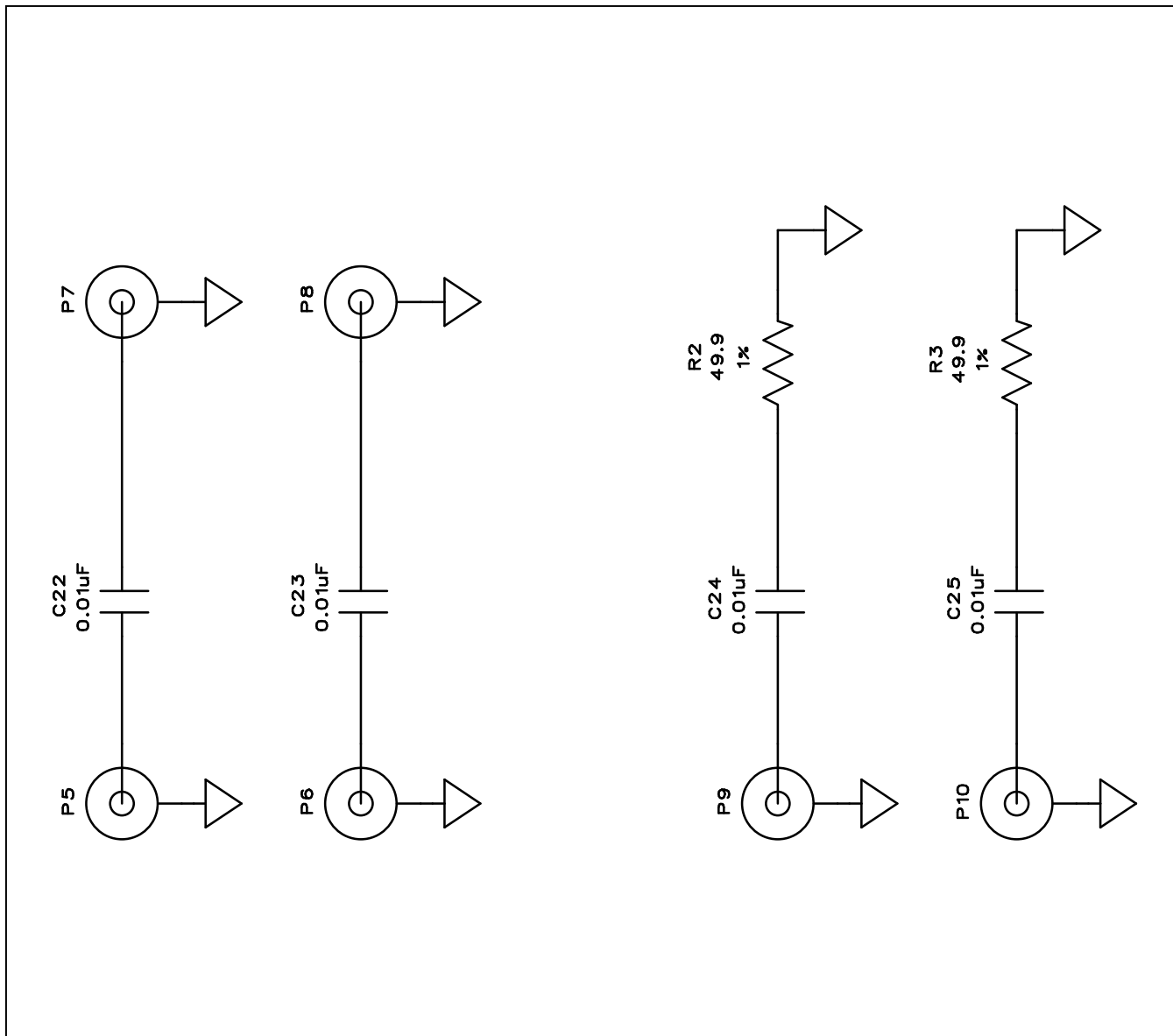

Figure 1c. MAX14970 EV Kit Schematic—Calibration Traces (Sheet 3 of 3)

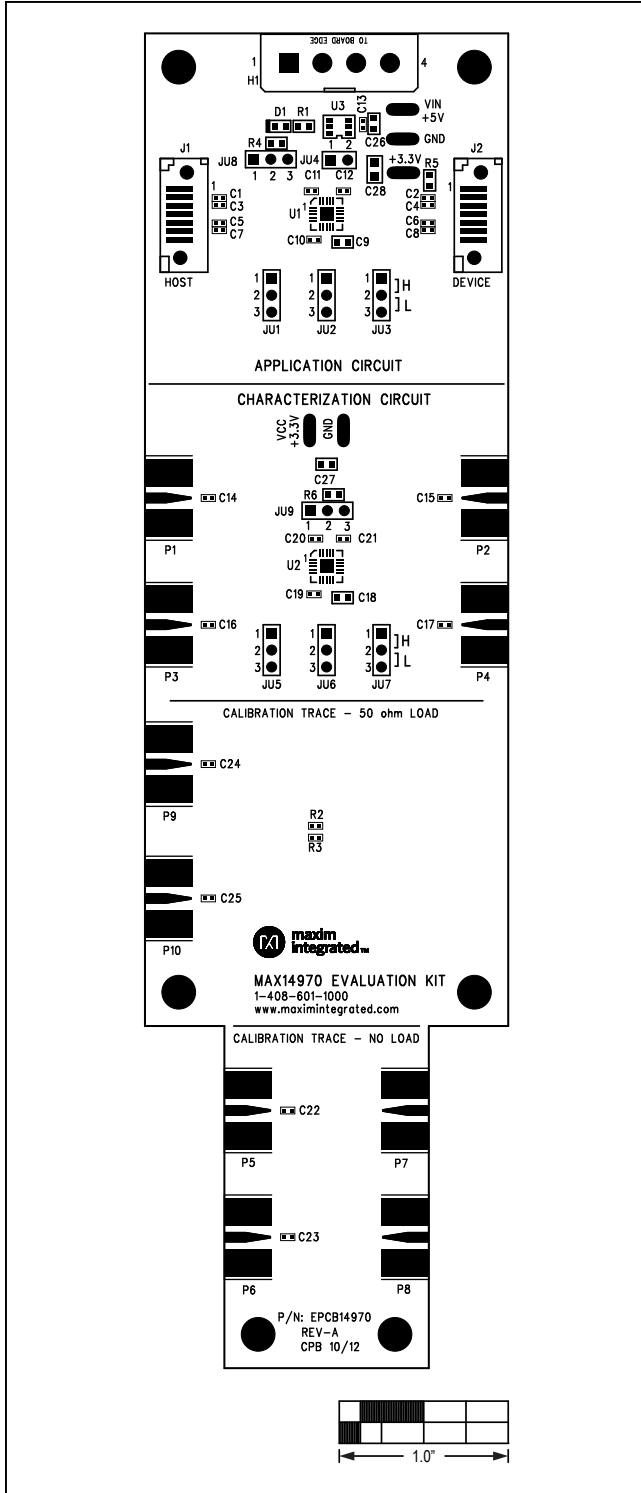

Figure 2. MAX14970 EV Kit Component Placement Guide—Component Side

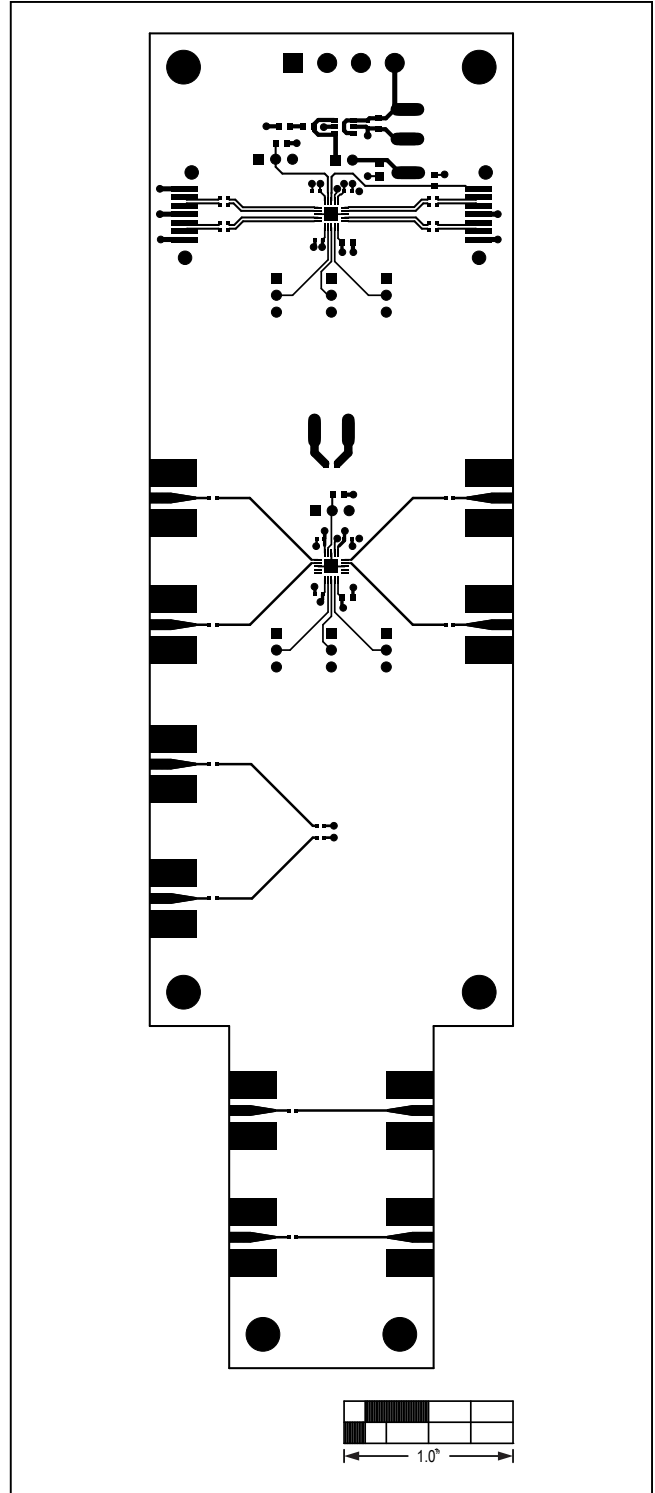

Figure 3. MAX14970 EV Kit Component PCB Layout—Component Side

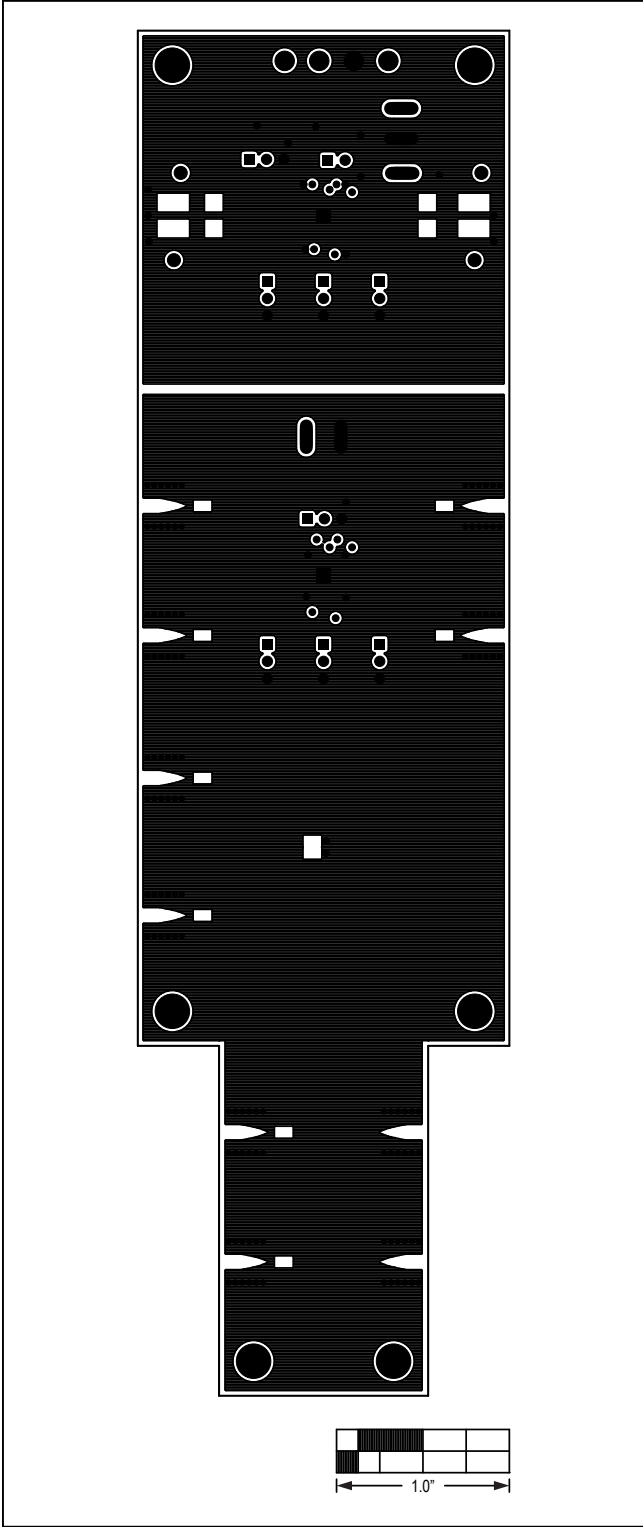

Figure 4. MAX14970 EV Kit PCB Layout—Inner Layer 2

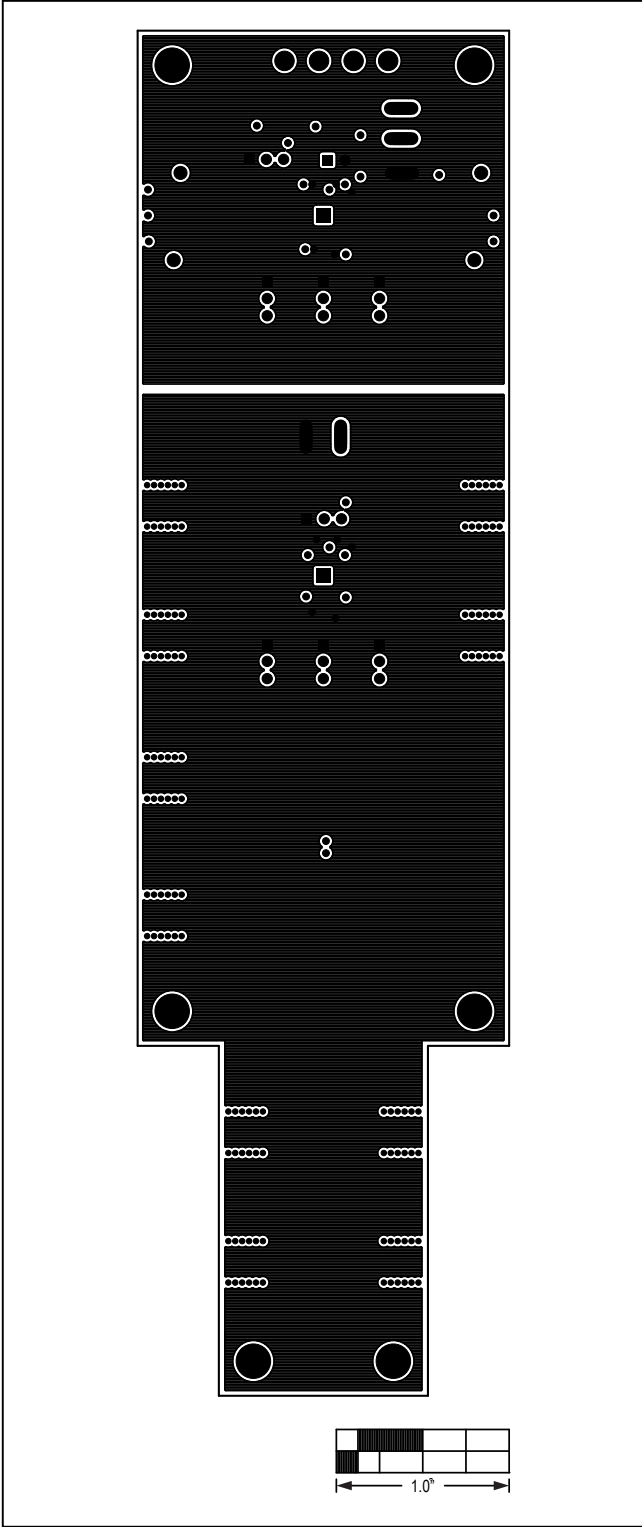

Figure 5. MAX14970 EV Kit PCB Layout—Inner Layer 3

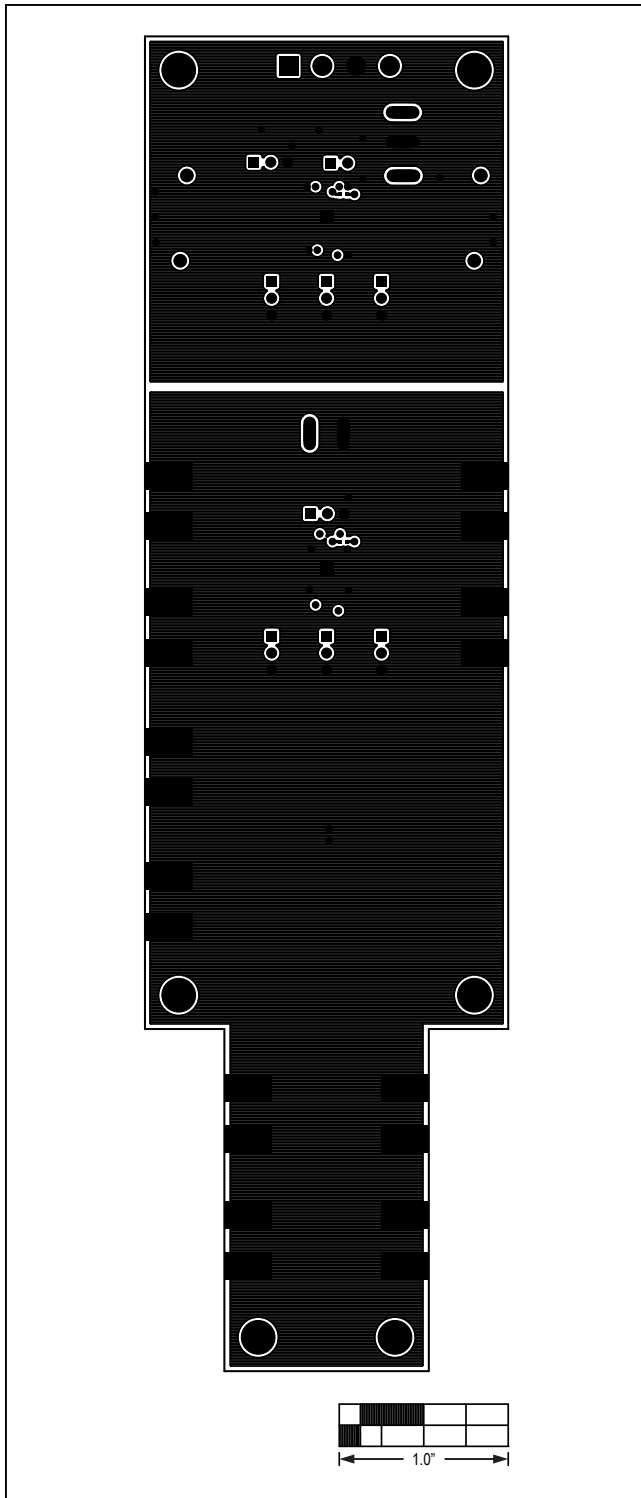

Figure 6. MAX14970 EV Kit PCB Layout—Solder Side

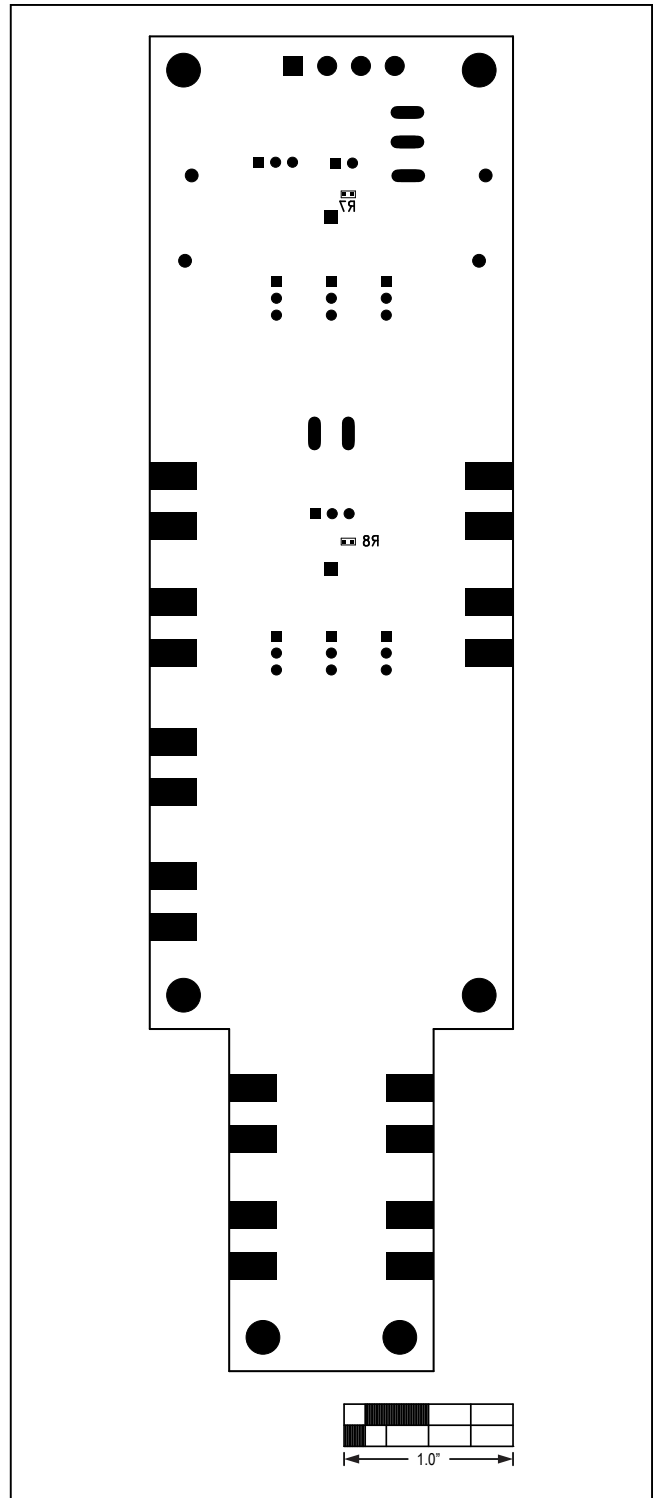

Figure 7. MAX14970 EV Kit Component Placement Guide—Solder Side

### Ordering Information

PART	TYPE
MAX14970EVKIT#	EV Kit

#Denotes RoHS compliant.

### Revision History

REVISION NUMBER	REVISION DATE	DESCRIPTION	PAGES CHANGED
0	9/13	Initial release	—

For pricing, delivery, and ordering information, please contact Maxim Direct at 1-888-629-4642, or visit Maxim Integrated's website at [www.maximintegrated.com](http://www.maximintegrated.com).

*Maxim Integrated cannot assume responsibility for use of any circuitry other than circuitry entirely embodied in a Maxim Integrated product. No circuit patent licenses are implied. Maxim Integrated reserves the right to change the circuitry and specifications without notice at any time.*