



Chipsmall Limited consists of a professional team with an average of over 10 year of expertise in the distribution of electronic components. Based in Hongkong, we have already established firm and mutual-benefit business relationships with customers from,Europe,America and south Asia,supplying obsolete and hard-to-find components to meet their specific needs.

With the principle of “Quality Parts,Customers Priority,Honest Operation,and Considerate Service”,our business mainly focus on the distribution of electronic components. Line cards we deal with include Microchip,ALPS,ROHM,Xilinx,Pulse,ON,Everlight and Freescale. Main products comprise IC,Modules,Potentiometer,IC Socket,Relay,Connector.Our parts cover such applications as commercial,industrial, and automotives areas.

We are looking forward to setting up business relationship with you and hope to provide you with the best service and solution. Let us make a better world for our industry!



Contact us

Tel: +86-755-8981 8866 Fax: +86-755-8427 6832

Email & Skype: info@chipsmall.com Web: www.chipsmall.com

Address: A1208, Overseas Decoration Building, #122 Zhenhua RD., Futian, Shenzhen, China





MAX15020 Evaluation Kit

Evaluates: MAX15020

General Description

The MAX15020 evaluation kit (EV kit) is a fully assembled and tested PCB that evaluates the MAX15020 PWM step-down regulator IC with an integrated high-side switch. The MAX15020 is equipped with a reference input for the feedback error amplifier, allowing dynamic output-voltage programming. The MAX15020 EV kit operates over a wide input-voltage range of 7.5V to 40V and provides up to 2A.

The MAX15020 internal switching frequency can be set to either 300kHz or 500kHz. The MAX15020 EV kit features a SYNC input to provide external frequency synchronization for sensitive applications. The EV kit uses a MAX15020 step-down regulator in a 20-pin thin QFN package. The MAX15020 IC operates over the automotive temperature range of -40°C to +125°C and is suitable for printers, industrial, and automotive applications.

Features

- ◆ Wide 7.5V to 40V Input Range
- ◆ Dynamic Output-Voltage Control from 0.8V to 36V with 2A Load
- ◆ Selectable 300kHz/500kHz Switching Frequency
- ◆ Turn-On/Off Control
- ◆ Demonstrates MAX15020 IC Low Shutdown Current
- ◆ High Efficiency up to 96% ($V_{IN} = 36V$, $V_{OUT} = 30V$, $I_{LOAD} = 2A$)
- ◆ Demonstrates MAX15020 IC Over-Current and Thermal Protection
- ◆ Space-Saving 5mm x 5mm, 20-pin TQFN Package
- ◆ Fully Assembled and Tested

Ordering Information

PART	TYPE
MAX15020EVKIT+	EV Kit

+ Denotes lead-free and RoHS compliant.

Component List

DESIGNATION	QTY	DESCRIPTION
C1, C6	2	560 μ F \pm 20%, 50V low ESR electrolytic capacitors (12.5mm x 25mm) SANYO 50ME560WX
C2, C4, C10	3	1 μ F \pm 10%, 25V X7R ceramic capacitors (0805) TDK C2012X7R1E105K
C3, C5, C7, C9	4	0.1 μ F \pm 10%, 50V X7R ceramic capacitors (0603) TDK C1608X7R1H104K
C8	1	0.22 μ F \pm 10%, 50V X7R ceramic capacitor (0805) Murata GRM21BR71H224K
C11	1	0.027 μ F \pm 10%, 50V X7R ceramic capacitor (0603) AVX 06035C273KAT2A
C12	1	0.1 μ F \pm 10%, 50V X7R ceramic capacitor (0805) TDK C2012X7R1H104K
C13	1	330pF \pm 5%, 50V C0G ceramic capacitor (0603) TDK C1608C0G1H331J

DESIGNATION	QTY	DESCRIPTION
D1	1	60V, 3A Schottky diode (SMA) Diodes Inc. B360A
D2	1	100V, 150mA Schottky diode (SOD-123) Vishay BAT46W
JU1, JU2, JU3	3	3-pin headers
L1	1	22 μ H, 4.7A inductor Sumida CDRH127/LDNP-220MC
R1	1	97.6k Ω \pm 1% resistor (0603)
R2	1	4.02k Ω \pm 1% resistor (0603)
R3, R4	2	10k Ω \pm 5% resistors (0603)
R5	1	10 Ω \pm 5% resistor (0603)
R6, R7	2	10k Ω \pm 1% resistors (0603)
R8	1	340 Ω \pm 1% resistor (0603)
R9	1	15.8k Ω \pm 1% resistor (0603)
R10	1	0 Ω \pm 5% resistor (0603)
R11	1	20k Ω \pm 1% resistor (0603)
TP1–TP4	4	PC mini red test points
U1	1	MAX15020ATP+ 20-pin TQFN (5mm x 5mm x 0.8mm)
—	3	Shunts (JU1, JU2, JU3)
—	1	PCB: MAX15020 Evaluation Kit+

MAX15020 Evaluation Kit

Component Suppliers

SUPPLIER	PHONE	WEBSITE
AVX Corp.	843-448-9411	www.avxcorp.com
Diodes Inc.	805-446-4800	www.diodes.com
Murata	770-436-1300	www.murata.com
SANYO	619-661-6835	www.sanyodevice.com
Sumida Corp.	847-545-6700	www.sumida.com
TDK Corp.	847-803-6100	www.component.tdk.com
Vishay	203-268-6261	www.vishay.com

Note: Indicate that you are using the MAX15020 when contacting these component suppliers.

Quick Start

Recommended Equipment

Before beginning, the following equipment is needed:

- 7.5V to 40V adjustable, 3A power supply
- 15Ω resistive load rated for 75W or greater
- Two digital voltmeters

Procedure

The MAX15020 EV kit is fully assembled and tested. Follow these steps to verify board operation. **Caution: Do not turn on the power supply until all connections are completed.**

- 1) Verify that a shunt is not installed at jumper JU1 (default 32V turn-on voltage).
- 2) Verify that shunts are installed on pins 1-2 of jumpers JU2 (REFIN = REFOUT) and JU3 (300kHz switching frequency).
- 3) Connect the resistive load between the OUT PCB pad and the PGND PCB pad.
- 4) Connect digital voltmeters across the IN and PGND pads, and the OUT and PGND pads on the EV kit board.
- 5) Connect the power supply's positive terminal to the IN PCB pad on the EV kit, and connect the power-supply ground terminal to the PGND PCB pad.
- 6) Turn on the power supply.
- 7) Set the power-supply voltage to 36V.
- 8) Verify that the voltmeter at OUT measures 30V.

Detailed Description of Hardware

The MAX15020 EV kit circuit uses a MAX15020 step-down regulator IC (U1) to implement a step-down DC-DC regulator circuit. The EV kit operates over a 7.5V to 40V input range. The circuit provides a dynamically programmable output range of 0.8V to 36V and can deliver up to 2A of current with excellent line and load regula-

tion. The MAX15020 step-down regulator features an internal high-side-low $R_{DS(ON)}$ MOSFET to achieve higher efficiency and lower overall system cost. The MAX15020 also features configurable soft-start, shut-down control, cycle-by-cycle current limit, hiccup-mode output short-circuit protection, and thermal shutdown. The undervoltage lockout (UVLO) threshold is configurable by choosing the appropriate R1 and R2 resistors.

The MAX15020 EV kit features a selectable 300kHz or 500kHz switching-frequency operation, in addition to a SYNC input that can be used to synchronize the MAX15020 to frequencies operating in the 300kHz to 500kHz range. An external reference input (REFIN_EXT) is available to dynamically change the output voltage.

Jumper Selection

ON/OFF Mode

The MAX15020 EV kit features a ON/OFF mode that reduces the MAX15020 supply current to 6μA (typ). The 3-pin jumper JU1 selects the ON/OFF mode for the MAX15020 EV kit. See Table 1 for jumper JU1 configurations.

Table 1. Jumper JU1 ON/OFF Mode

SHUNT LOCATION	ON/OFF PIN	MAX15020 OUTPUT
1-2	Connects to V_{IN} directly	MAX15020 enabled
2-3	Connects to GND	MAX15020 disabled
None*	Connects to V_{IN} through R1 and R2 resistors	MAX15020 enabled at $V_{IN} \cong 32V$

*Default position.

REFIN_EXT Input

The MAX15020 features a reference input for the internal error amplifier. The voltage applied to REFIN_EXT PCB pad is used to dynamically change the circuit's output voltage. Jumper JU2 connects REFIN to REFOUT to use the MAX15020's 1V internal reference voltage. See Table 2 for jumper JU2 configurations. To change the MAX15020 EV kit output voltage using REFIN_EXT, refer to the *Setting the Output Voltage* section in the MAX15020 IC data sheet.

Table 2. Jumper JU2 Reference-Voltage Input

SHUNT LOCATION	REFIN PIN	V_{OUT}
1-2*	Connects directly to REFOUT	30V
2-3	Externally controlled by REFIN_EXT voltage	Dependent on voltage at REFIN_EXT

*Default position.

MAX15020 Evaluation Kit

Frequency Selection

Jumper JU3 selects the MAX15020 operating switching frequency between 300kHz or 500kHz. See Table 3 for switching frequency selection.

Table 3. Jumper JU3 Frequency Selection

SHUNT LOCATION	FSEL PIN	MAX15020 SWITCHING FREQUENCY
1-2*	Connects to VREG	300kHz
2-3	Connects to GND	500kHz

*Default position. When operating the MAX15020 with an external clock signal at SYNC, place the shunt on pins 1-2. Refer to the *Oscillator/Synchronization Input* section of the MAX15020 IC data sheet for more information.

Configuring the Output Voltage (OUT)

The MAX15020 EV kit step-down regulator output voltage is configured to 30V by resistors R7 and R8, and with $REFIN = REFOUT$. The EV kit's output voltage (OUT) can be reconfigured in the range of 0.8V to 36V by replacing resistors R7 and R8. To select a new value for resistor R8, refer to the *Compensation Design* section in the MAX15020 IC data sheet. Use the following equation to reconfigure the output voltage to the desired value:

$$R8 = \frac{R7}{\left[\frac{V_{OUT}}{V_{REFIN}} - 1 \right]}$$

where V_{OUT} is the desired output voltage in volts, V_{REFIN} is the voltage supplied by REFOUT or REFIN_EXT, and R7 is typically 10k Ω .

The MAX15020 output voltage can also be adjusted dynamically by driving REFIN_EXT between 0 and 3.6V. To use the REFIN_EXT input, place a shunt across pins 2-3 of jumper JU2.

Reconfiguring the MAX15020 EV kit for a new output voltage may require replacing inductor L1 and capacitors C1 and/or C6. To select a new value for inductor L1 and capacitors C1 and C6, refer to the *Inductor Selection*, *Output Capacitor Selection*, and *Input Capacitor Selection* sections, respectively, in the MAX15020 IC data sheet.

Configuring the ON/OFF Threshold

The MAX15020 EV kit turn-on threshold is configured to 32V with resistors R1 and R2. The MAX15020 turns on when the input voltage (V_{IN}) is approximately above 32V and ON/OFF is $\geq 1.23V$. The ON/OFF threshold can be reconfigured to a desired value by appropriately selecting resistors R1 and R2. Refer to *Setting the ON/OFF Threshold* section in the MAX15020 IC data sheet. To reconfigure the UVLO threshold, use the following equation:

$$R1 = R2 \times \left[\frac{V_{UVLO}}{1.23} - 1 \right]$$

where resistor R1 should be in the range of 100k Ω and V_{UVLO} is the desired UVLO threshold in volts.

Place a shunt across pins 1-2 of jumper JU1 for always-on operation, which bypasses the on/off threshold. Resistor R11 is utilized to prevent excessive power dissipation in resistor R2 when the shunt at jumper JU1 is installed on pins 1-2.

Synchronization Input (SYNC)

The MAX15020 EV kit circuit features a selectable 300kHz or 500kHz switching frequency. Jumper JU3 sets the internal switching frequency. The EV kit's SYNC PCB pad can be used to synchronize the MAX15020 with an external digital clock in the range of 300kHz to 500kHz. When SYNC is driven with an external digital clock, the MAX15020 synchronizes to the rising edge of the external clock.

The digital square-wave clock source must provide the following signal qualities:

- Output voltage: Logic-low = 0 to 0.8V, logic-high = 2V to 5.5V
- Input frequency = 300kHz to 500kHz (refer to the MAX15020 IC data sheet for more information on the SYNC input)
- Minimum pulse width = 200ns

To use external synchronization, connect the external square-wave clock to the SYNC and GND pads.

Evaluates: MAX15020

MAX15020 Evaluation Kit

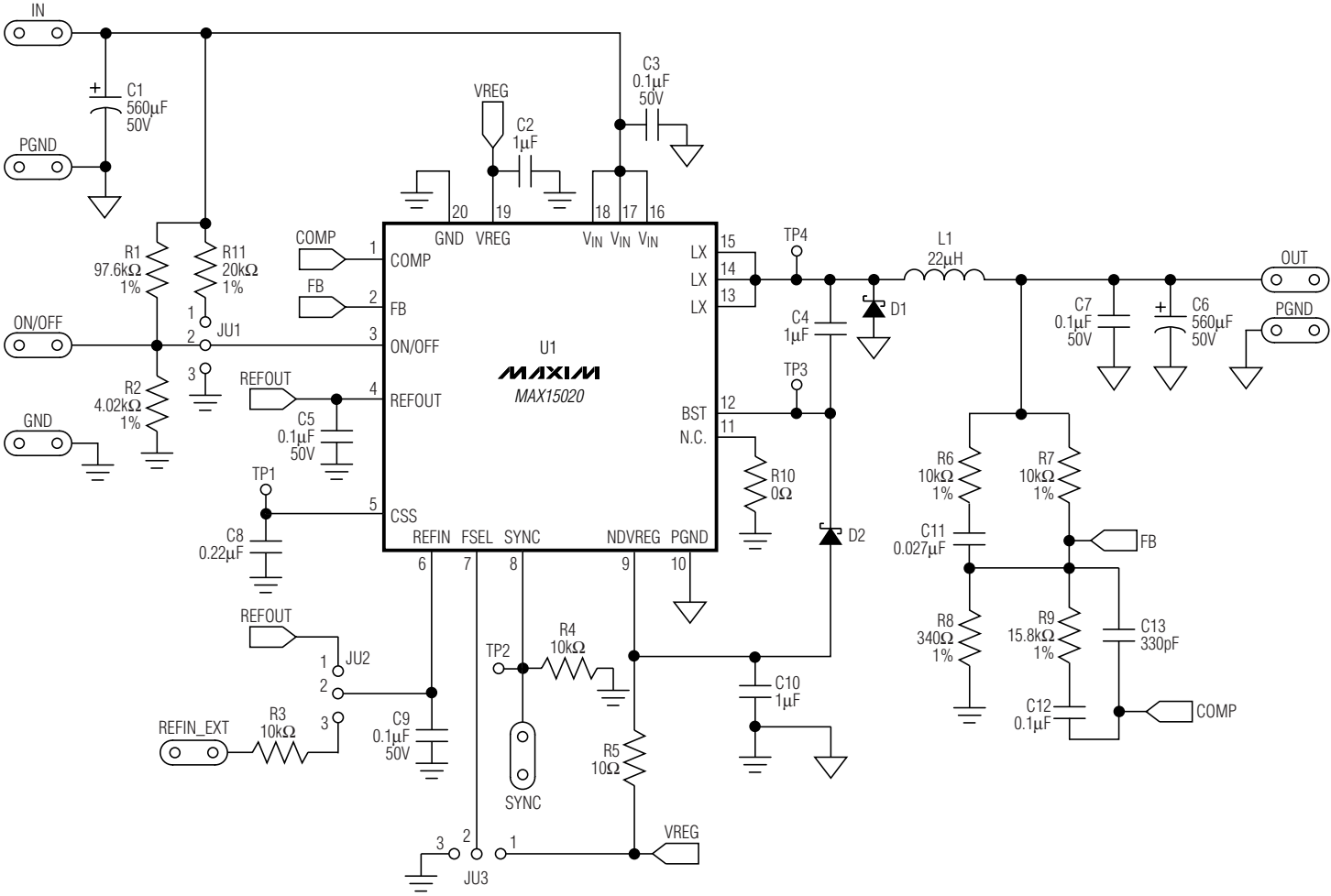

Figure 1. MAX15020 EV Kit Schematic

MAX15020 Evaluation Kit

Evaluates: MAX15020

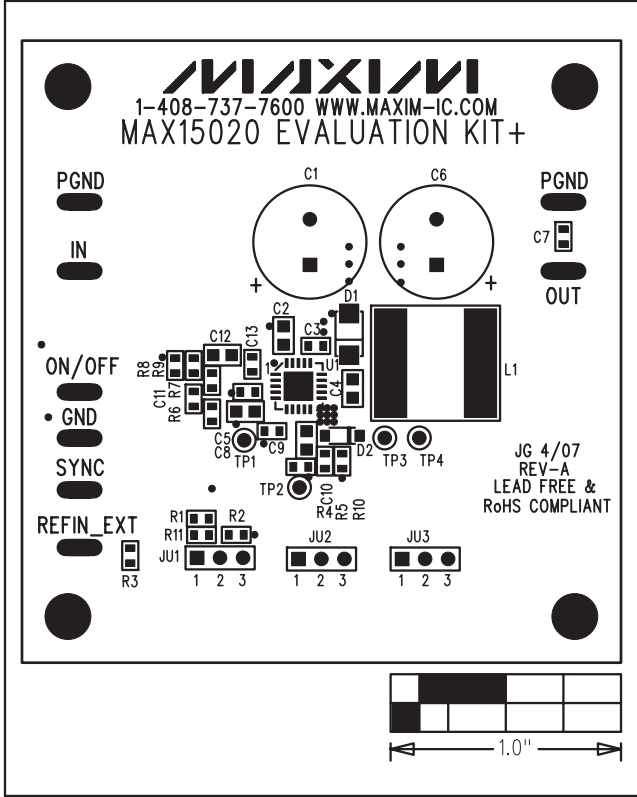

Figure 2. MAX15020 EV Kit Component Placement Guide—Component Side

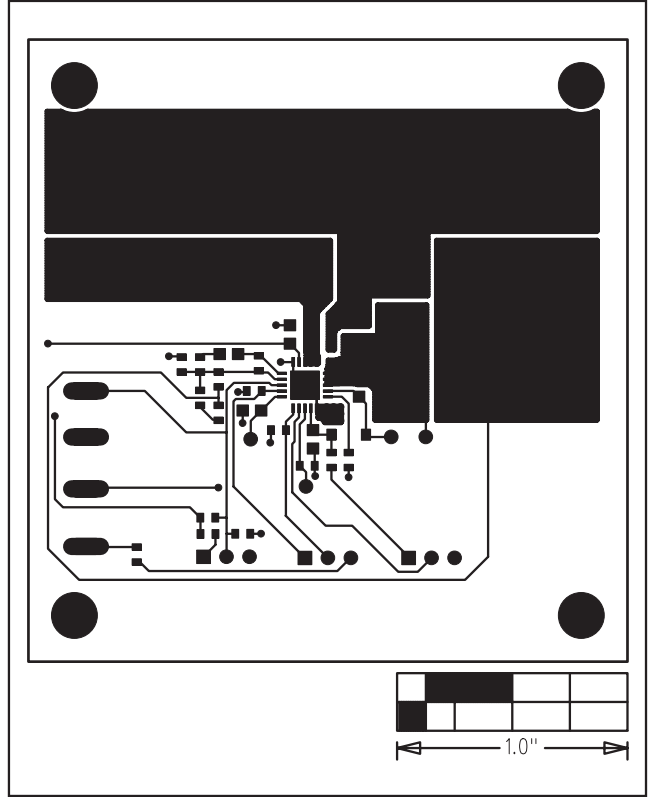

Figure 3. MAX15020 EV Kit PCB Layout—Component Side

MAX15020 Evaluation Kit

Evaluates: MAX15020

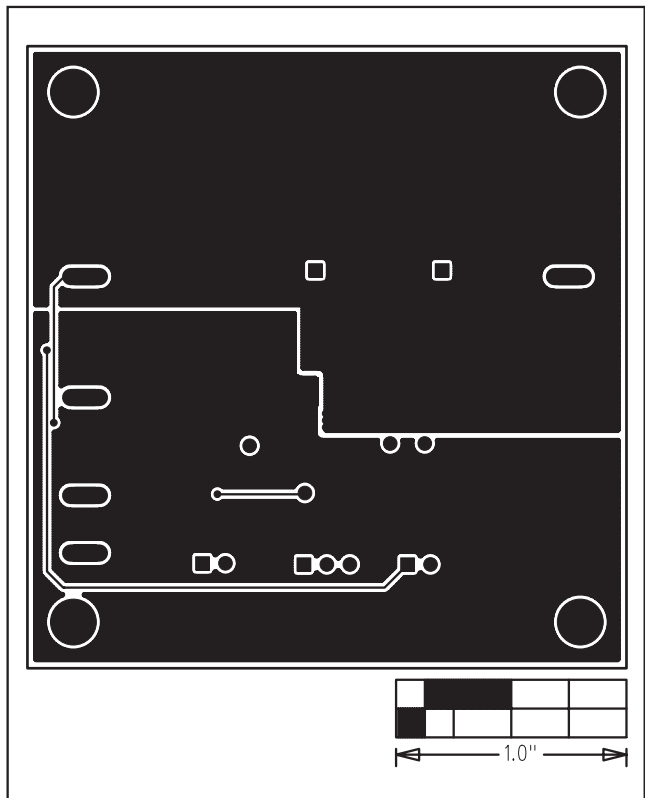

Figure 4. MAX15020 EV Kit PCB Layout—GND Layer 2

MAX15020 Evaluation Kit

Revision History

REVISION NUMBER	REVISION DATE	REVISION DESCRIPTION	PAGES CHANGED
0	4/07	Initial release	—
1	11/07	Updated <i>Ordering Information</i> table format; corrections to <i>Procedures</i> (step 2), <i>Configuring ON/OFF Threshold</i> , and Figure 1.	1-4
2	6/08	Changed part number for C13 in <i>Component List</i> .	1

Evaluates: MAX15020

Maxim cannot assume responsibility for use of any circuitry other than circuitry entirely embodied in a Maxim product. No circuit patent licenses are implied. Maxim reserves the right to change the circuitry and specifications without notice at any time.

Maxim Integrated Products, 120 San Gabriel Drive, Sunnyvale, CA 94086 408-737-7600 _____ 7