



Chipsmall Limited consists of a professional team with an average of over 10 year of expertise in the distribution of electronic components. Based in Hongkong, we have already established firm and mutual-benefit business relationships with customers from,Europe,America and south Asia,supplying obsolete and hard-to-find components to meet their specific needs.

With the principle of “Quality Parts,Customers Priority,Honest Operation,and Considerate Service”,our business mainly focus on the distribution of electronic components. Line cards we deal with include Microchip,ALPS,ROHM,Xilinx,Pulse,ON,Everlight and Freescale. Main products comprise IC,Modules,Potentiometer,IC Socket,Relay,Connector.Our parts cover such applications as commercial,industrial, and automotives areas.

We are looking forward to setting up business relationship with you and hope to provide you with the best service and solution. Let us make a better world for our industry!



## Contact us

Tel: +86-755-8981 8866 Fax: +86-755-8427 6832

Email & Skype: info@chipsmall.com Web: www.chipsmall.com

Address: A1208, Overseas Decoration Building, #122 Zhenhua RD., Futian, Shenzhen, China





# MAX15059 Evaluation Kit

## General Description

The MAX15059 evaluation kit (EV kit) demonstrates the MAX15059 APD biasing pulse-width modulation (PWM) step-up DC-DC converter with an internal power switch, current monitor, and adjustable current limiting. The step-up converter switches at 400kHz. The EV kit operates from a DC supply voltage of 2.8V to 5.5V and is configured to deliver approximately 70V, and 0 to 4mA of current at the output. The output voltage can be configured from VIN + 5V to 76V by replacing a resistor or adjusting the CNTRL voltage. The EV kit demonstrates the IC's APD fast current-limit, undervoltage-lockout (UVLO), and thermal-shutdown features.

The EV kit also features an APD input load-simulator circuit for current monitoring and step-response measurements.

The EV kit comes with the MAX15059AETE+ installed, but can also be used to evaluate the MAX15059BETE+.

**Warning: Voltages exceeding 42V may exist on the VOUT, APD, MOUT, and PGND PCB pads.**

## Features

- ◆ 2.8V to 5.5V Supply Voltage Range
- ◆ 70V Output Voltage (Approximate)
- ◆ 0 to 4mA Output Current
- ◆ Demonstrates APD Fast Current Limit
- ◆ Demonstrates Undervoltage Lockout
- ◆ Demonstrates Thermal-Shutdown Feature
- ◆ MOUT Output Overvoltage Protection Through Clamping Circuit
- ◆ Fully Assembled and Tested

## Ordering Information

PART	TYPE
MAX15059EVKIT+	EV Kit

+Denotes lead(Pb)-free and RoHS compliant.

## Component List

DESIGNATION	QTY	DESCRIPTION
C1	1	1 $\mu$ F $\pm$ 10%, 10V X5R ceramic capacitor (0402) Murata GRM155R61A105K
C3	1	0.1 $\mu$ F $\pm$ 10%, 16V X7R ceramic capacitor (0402) Murata GRM155R71C104K
C4, C5	2	0.1 $\mu$ F $\pm$ 10%, 100V X7R ceramic capacitors (0805) AVX 08051C104KAT
C6	1	0.01 $\mu$ F $\pm$ 10%, 100V X7R ceramic capacitor (0805) Murata GRM21BR72A103K
C7	0	Not installed, ceramic capacitor (0402)
C9	1	10 $\mu$ F $\pm$ 10%, 10V X5R ceramic capacitor (0805) Murata GRM219R61A106K
D1	1	100V, 150mA Schottky diode (SOD123) Diodes Inc. BAT46W-7-F (Top Mark: L6)

DESIGNATION	QTY	DESCRIPTION
JU1, JU3	2	2-pin headers
JU2	1	3-pin header
L1	1	4.7 $\mu$ H, 1.5A inductor Coilcraft ME3220-472MLB
N1	1	100V, 1.5A n-channel MOSFET (SOT23) Vishay Si2328DS-T1-E3 (Top Mark: CHV)
R1	1	348k $\Omega$ $\pm$ 1% resistor (0603)
R2	1	6.34k $\Omega$ $\pm$ 1% resistor (0402)
R3	1	1k $\Omega$ $\pm$ 1% resistor (0402)
R5	1	2.87k $\Omega$ $\pm$ 1% resistor (0402)
R6	1	10k $\Omega$ $\pm$ 1% resistor (0402)
R7	1	10k $\Omega$ $\pm$ 1% resistor (0805)
R8	1	20k $\Omega$ $\pm$ 1% resistor (1206)
R9	1	3.3k $\Omega$ $\pm$ 1% resistor (0805)
R10	1	100 $\Omega$ $\pm$ 1% resistor (0402)
TP1, TP2, TP4	3	PC mini red test points
TP3, TP6	2	PC mini black test points
TP5	1	PC mini yellow test point

Evaluates: MAX15059A/MAX15059B





# MAX15059 Evaluation Kit

## Component List (continued)

DESIGNATION	QTY	DESCRIPTION
U1	1	APD boost converter (16 TQFN-EP*) Maxim MAX15059AETE+

DESIGNATION	QTY	DESCRIPTION
—	3	Shunts
—	1	PCB: MAX15059 EVALUATION KIT+

\*EP = Exposed pad.

## Component Suppliers

SUPPLIER	PHONE	WEBSITE
AVX Corporation	843-946-0238	www.avxcorp.com
Coilcraft, Inc.	847-639-6400	www.coilcraft.com
Diodes Incorporated	805-446-4800	www.diodes.com
Murata Electronics North America, Inc.	770-436-1300	www.murata-northamerica.com
Vishay	402-563-6866	www.vishay.com

**Note:** Indicate that you are using the MAX15059 when contacting these component suppliers.

## Quick Start

### Required Equipment

- MAX15059 EV kit
- 2.8V to 5.5V, 1A DC power supply
- 0 to 5mA adjustable load rated for at least 76V
- Digital multimeter (DMM)

**Warning: Voltages exceeding 42V may exist on the VOUT, APD, MOUT, and PGND PCB pads.**

### Procedure

The EV kit is fully assembled and tested. Follow the steps below to verify board operation. **Caution: Do not turn on the power supply until all connections are completed.**

- 1) Verify that a shunt is installed on jumper JU1 (70V output).
- 2) Verify that a shunt is installed on pins 1-2 of jumper JU2 (enabled).
- 3) Verify that a shunt is not installed on jumper JU3 (APD current limit is programmed by R5).
- 4) Connect the adjustable load to the APD and SGND PCB pads.
- 5) Connect the power supply to the VIN pad and the power-supply ground to the PGND pad.
- 6) Connect the DMM across the APD and SGND PCB pads.
- 7) Turn on the power supply and set it to 3.3V.
- 8) Verify that the DMM reads approximately 70V.

## Detailed Description of Hardware

The MAX15059 EV kit demonstrates the MAX15059 in a small, 16-pin TQFN package with internal power switch, current monitor, and adjustable current-limiting circuit features. The circuit's PWM step-up DC-DC converter is designed for APD biasing, switches at 400kHz, and is configured to deliver approximately 70V, and 0 to 4mA of current to the APD output. The output voltage can be reconfigured from VIN + 5V to 76V by replacing resistor R1, or adjusting the CNTRL voltage. The EV kit demonstrates the IC's APD fast current-limit, UVLO, and thermal-shutdown features.

The converter circuit's PCB footprint is 8mm x 18mm. The EV kit operates from a 2.8V to 5.5V DC supply voltage and provides up to 4mA at the APD output. The EV kit's APD load-simulator circuit is used for current monitoring and step-response measurements. The circuit is comprised of MOSFET N1, resistors R7, R8, R9, and test points TP1, TP2, and TP3 (SGND). Test point TP4 provides access to the IC's BIAS signal. **Voltages exceeding 42V may exist on TP4.** Additionally, bulk capacitor C9 is provided in case long connecting cables are used to power the EV kit during lab evaluation. Capacitor C9 is not required in a typical design.

### SHDN and Enable

The EV kit features a jumper to enable and disable U1. Jumper JU2 disables the EV kit when the shunt is installed on pins 2-3. Installing the shunt on pins 1-2 enables the EV kit. Refer to the *Shutdown* section in the MAX15059 IC data sheet for more information. See Table 1 for jumper JU2 settings.

# MAX15059 Evaluation Kit

Evaluates: MAX15059A/MAX15059B

**Table 1. SHDN and Enable (JU2)**

SHUNT POSITION	SHDN PIN	EV KIT OPERATION
1-2*	Connected to VIN	Enabled
2-3	Connected to SGND	Disabled

\*Default position.

**Table 2. Output-Voltage Programming (JU1)**

SHUNT POSITION	CNTRL PIN	OUTPUT-VOLTAGE PROGRAMMING
Installed*	Connected to VIN	Fixed output voltage: Internal reference voltage used.
Not installed	Connected to external reference	Programmable output voltage: Apply an external reference voltage (< 1.2V) at CNTRL PCB pad.
Not installed	Connected to external reference	Fixed output voltage: Apply an external reference voltage (> 1.3V)** at CNTRL PCB pad; internal reference voltage used.

\*Default position.

\*\*Apply a voltage > 1.3V to use the MAX15059 internal reference. The voltage should be 1.5V to VIN voltage. Refer to the Adjusting the Feedback Set-Point/Reference Voltage section in the MAX15059 IC data sheet for more information.

## Output-Voltage Programmability

The EV kit features a jumper to set the output voltage (VOUT/APD) programmability. VOUT/APD is programmed by connecting an external reference voltage source to the CNTRL and SGND PCB pads. Remove the shunt at jumper JU1 to use the programmability feature and apply a reference voltage < 1.2V to the CNTRL PCB pad. When the voltage applied to the CNTRL pad is > 1.3V, the IC's internal reference is used. See Table 2 for jumper JU1 settings.

The output voltage at VOUT is set by resistors R1 and R2 to 70V when jumper JU1 is installed. To reconfigure the output for a different voltage (VIN + 5V to 76V), select a new surface-mount 0603 resistor for R1. Refer to the *Setting the Output Voltage* section in the MAX15059 IC data sheet for selecting the R1 value.

**Table 3. RLIM (JU3)**

SHUNT POSITION	CURRENT-LIMIT THRESHOLD
Installed	Default setting of 4.6mA
Not installed*	Programmed by R5

\*Default position.

## Current-Monitor Output (MOUT) and APD Load Simulator

The MOUT PCB pad provides a current-monitor output that sources a current equal to the APD current in the MAX15059A and 1/5th the APD current in the MAX15059B. An RC network comprised of resistor R3 and capacitor C7 provide a filter to the MOUT signal. Capacitor C7 is not required in a typical design.

Additionally, resistors R8 and R9 set the APD load-simulator circuit's current for current-monitor step-response measurements. Apply a 0 to 11V square-wave signal to the APD\_DRV PCB pad to simulate a 0 to 4mA load. Use test point TP1 or TP2 to measure the APD load current and TP3 as the SGND.

## Clamp Input (CLAMP)

CLAMP provides a means for diode clamping the voltage at MOUT; thus, VMOUT is limited to (VCLAMP + 0.6V). CLAMP can be connected to either an external supply or BIAS (TP4). Leave CLAMP unconnected if voltage clamping is not required.

## Setting Fast Current-Limit Threshold and ILIM

Resistor R5 sets the IC's APD fast current-limit threshold to 2.22mA. To reconfigure the circuit for another current-limit threshold, replace resistor R5 and use the following equation to calculate a new value for the desired current:

$$R5(k\Omega) = \left[ \left( \frac{1.23V}{I_{LIM}(mA)} \right) \times 10 - 2.67k\Omega \right]$$

where ILIM is the desired DC load current in milliamps. Place a shunt on jumper JU3 to connect RLIM to SGND and set the current-limit threshold to 4.6mA. See Table 3 for jumper JU3 settings.

The ILIM open-drain signal is available at the ILIM PCB pad. During normal EV kit operation, resistor R6 pulls up the ILIM pin to VIN. ILIM asserts low when the APD current limit has been exceeded.

# MAX15059 Evaluation Kit

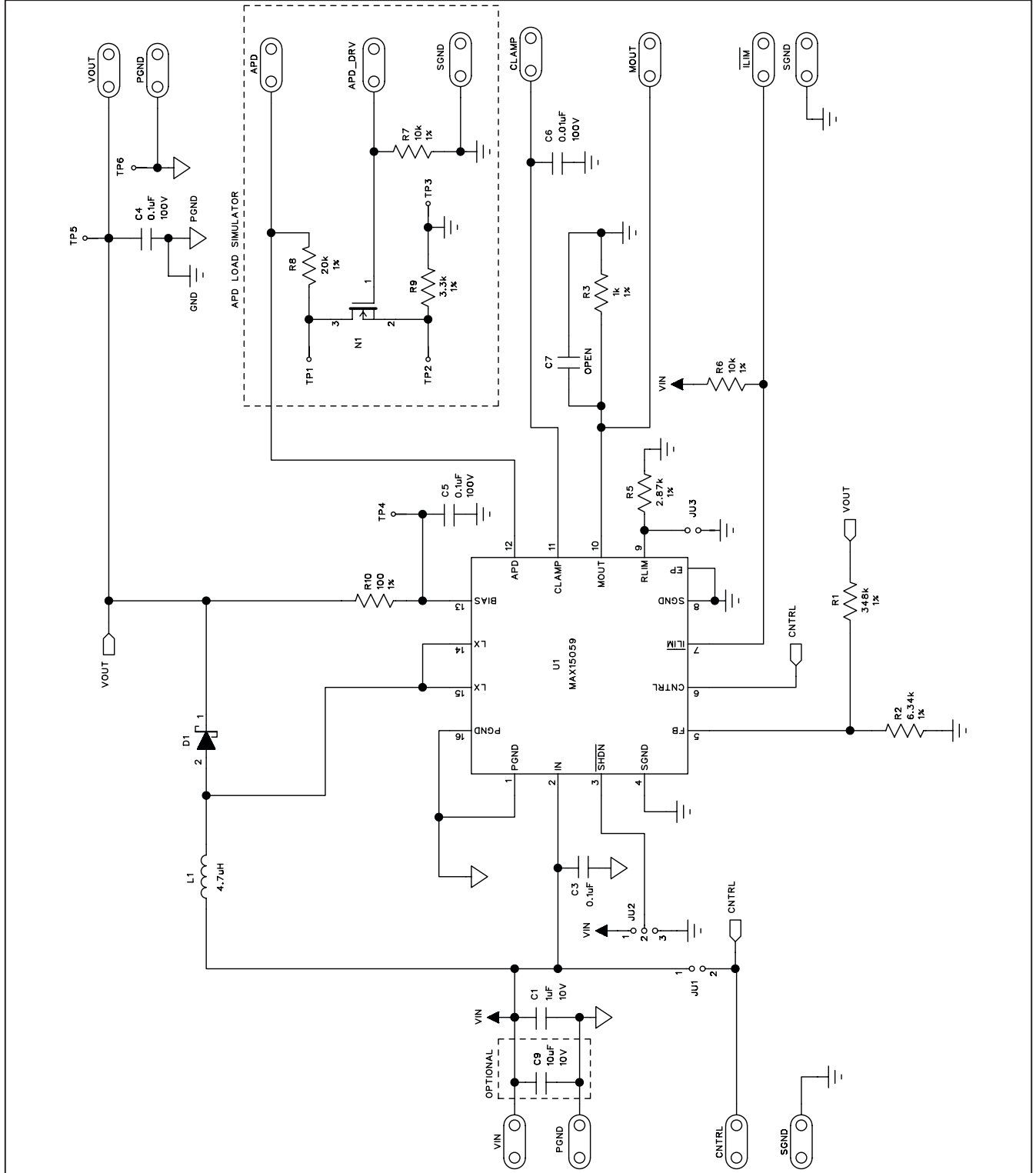

Figure 1. MAX15059 EV Kit Schematic

# MAX15059 Evaluation Kit

Evaluates: MAX15059A/MAX15059B

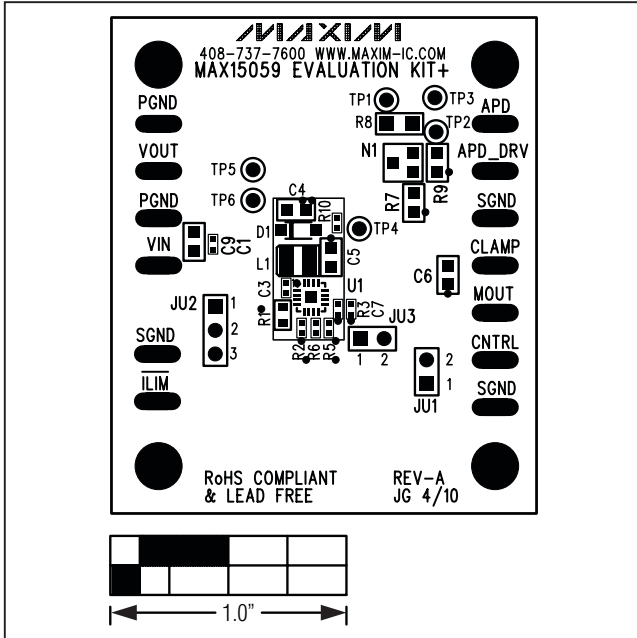

Figure 2. MAX15059 EV Kit Component Placement Guide—Component Side

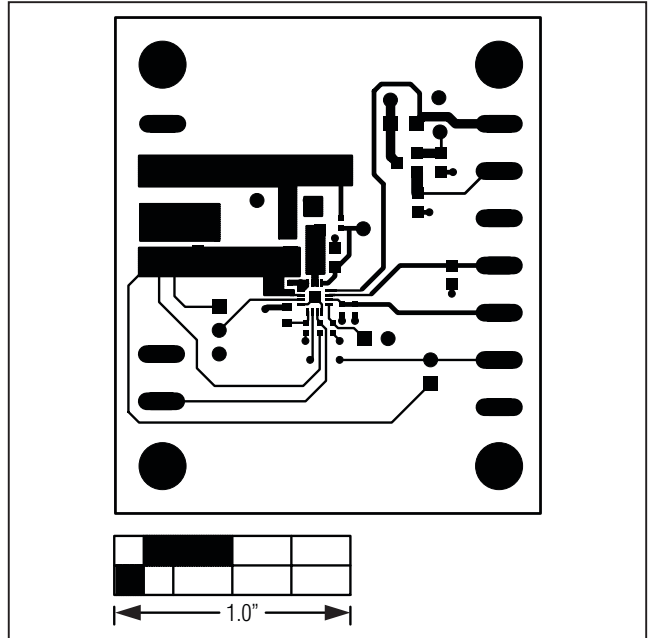

Figure 3. MAX15059 EV Kit PCB Layout—Component Side

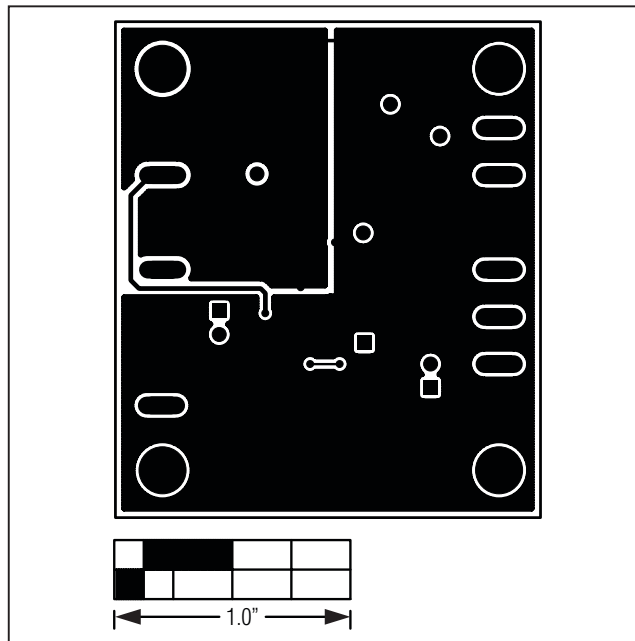

Figure 4. MAX15059 EV Kit PCB Layout—Solder Side

# MAX15059 Evaluation Kit

**Evaluates: MAX15059A/MAX15059B**

## Revision History

REVISION NUMBER	REVISION DATE	DESCRIPTION	PAGES CHANGED
0	5/10	Initial release	—

Maxim cannot assume responsibility for use of any circuitry other than circuitry entirely embodied in a Maxim product. No circuit patent licenses are implied. Maxim reserves the right to change the circuitry and specifications without notice at any time.

6 \_\_\_\_\_ **Maxim Integrated Products, 120 San Gabriel Drive, Sunnyvale, CA 94086 408-737-7600**

© 2010 Maxim Integrated Products

Maxim is a registered trademark of Maxim Integrated Products, Inc.