



Chipsmall Limited consists of a professional team with an average of over 10 year of expertise in the distribution of electronic components. Based in Hongkong, we have already established firm and mutual-benefit business relationships with customers from,Europe,America and south Asia,supplying obsolete and hard-to-find components to meet their specific needs.

With the principle of “Quality Parts,Customers Priority,Honest Operation,and Considerate Service”,our business mainly focus on the distribution of electronic components. Line cards we deal with include Microchip,ALPS,ROHM,Xilinx,Pulse,ON,Everlight and Freescale. Main products comprise IC,Modules,Potentiometer,IC Socket,Relay,Connector.Our parts cover such applications as commercial,industrial, and automotives areas.

We are looking forward to setting up business relationship with you and hope to provide you with the best service and solution. Let us make a better world for our industry!



Contact us

Tel: +86-755-8981 8866 Fax: +86-755-8427 6832

Email & Skype: info@chipsmall.com Web: www.chipsmall.com

Address: A1208, Overseas Decoration Building, #122 Zhenhua RD., Futian, Shenzhen, China



High-Efficiency, 5x Output, Main Power-Supply Controllers for Notebook Computers

General Description

The MAX1533/MAX1537 are dual step-down, switch-mode power-supply (SMPS) controllers with synchronous rectification, intended for main 5V/3.3V power generation in battery-powered systems. Fixed-frequency operation with optimal interleaving minimizes input ripple current from the lowest input voltages up to the 26V maximum input. Optimal 40/60 interleaving allows the input voltage to go down to 8.3V before duty-cycle overlap occurs, compared to 180° out-of-phase regulators where the duty-cycle overlap occurs when the input drops below 10V. Output current sensing provides accurate current limit using a sense resistor. Alternatively, power dissipation can be reduced using lossless inductor current sensing.

Internal 5V and 3.3V linear regulators power the MAX1533/MAX1537 and their gate drivers, as well as external keep-alive loads, up to a total of 100mA. When the main PWM regulators are in regulation, automatic bootstrap switches bypass the internal linear regulators, providing currents up to 200mA from each linear output. An additional 5V to 23V adjustable internal 150mA linear regulator is typically used with a secondary winding to provide a 12V supply.

The MAX1533/MAX1537 include on-board power-up sequencing, a power-good (PGOOD) output, digital soft-start, and internal soft-shutdown output discharge that prevents negative voltages on shutdown. The MAX1533 is available in a 32-pin 5mm x 5mm thin QFN package, and the MAX1537 is available in a 36-pin 6mm x 6mm thin QFN package. The exposed backside pad improves thermal characteristics for demanding linear keep-alive applications.

Applications

- 2 to 4 Li+ Cells Battery-Powered Devices
- Notebook and Subnotebook Computers
- PDA's and Mobile Communicators

Ordering Information

PART	TEMP RANGE	PIN-PACKAGE
MAX1533ETJ	-40°C to +85°C	32 Thin QFN 5mm x 5mm
MAX1533ETJ+	-40°C to +85°C	32 Thin QFN 5mm x 5mm
MAX1537ETX	-40°C to +85°C	36 Thin QFN 6mm x 6mm
MAX1537ETX+	-40°C to +85°C	36 Thin QFN 6mm x 6mm

+ Denotes lead-free package.

Dual Mode is a trademark of Maxim Integrated Products, Inc.

Features

- ◆ Fixed-Frequency, Current-Mode Control
- ◆ 40/60 Optimal Interleaving
- ◆ Accurate Differential Current-Sense Inputs
- ◆ Internal 5V and 3.3V Linear Regulators with 100mA Load Capability
- ◆ Auxiliary 12V or Adjustable 150mA Linear Regulator (MAX1537 Only)
- ◆ Dual-Mode™ Feedback—3.3V/5V Fixed or Adjustable Output (Dual Mode) Voltages
- ◆ 200kHz/300kHz/500kHz Switching Frequency
- ◆ Versatile Power-Up Sequencing
- ◆ Adjustable Overvoltage and Undervoltage Protection
- ◆ 6V to 26V Input Range
- ◆ 2V ±0.75% Reference Output
- ◆ Power-Good Output
- ◆ Soft-Shutdown
- ◆ 5μA (typ) Shutdown Current

Pin Configurations

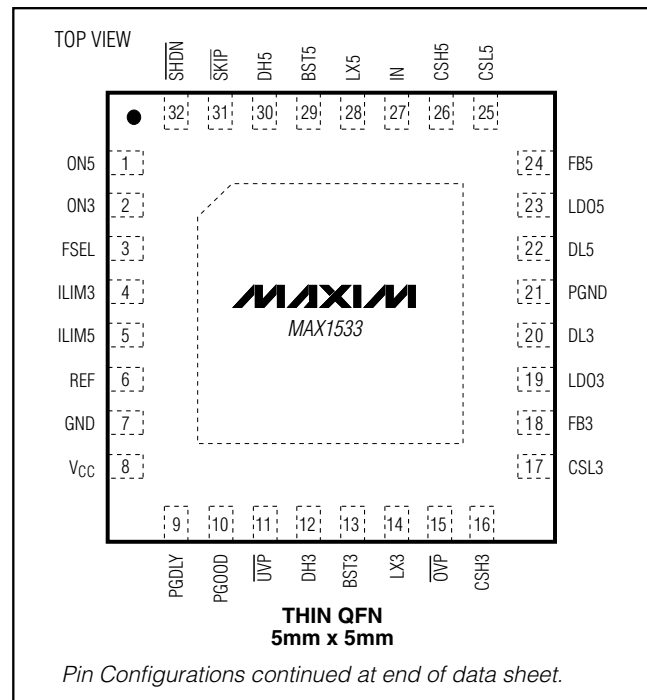

High-Efficiency, 5x Output, Main Power-Supply Controllers for Notebook Computers

ABSOLUTE MAXIMUM RATINGS

IN, SHDN, INA, LDOA to GND	-0.3V to +30V
GND to PGND	-0.3V to +0.3V
LDO5, LDO3, V _{CC} to GND	-0.3V to +6V
ILIM3, ILIM5, PGDLY to GND	-0.3V to +6V
CSL3, CSH3, CSL5, CSH5 to GND	-0.3V to +6V
ON3, ON5, FB3, FB5 to GND	-0.3V to +6V
SKIP, OVP, UVP to GND	-0.3V to +6V
PGOOD, FSEL, ADJA, ONA to GND	-0.3V to +6V
REF to GND	-0.3V to (V _{CC} + 0.3V)
DL3, DL5 to PGND	-0.3V to (V _{LDO5} + 0.3V)
BST3, BST5 to PGND	-0.3V to +36V
LX3 to BST3	-6V to +0.3V
DH3 to LX3	-0.3V to (V _{BST3} + 0.3V)

LX5 to BST5	-6V to +0.3V
DH5 to LX5	-0.3V to (V _{BST5} + 0.3V)
LDO3, LDO5 Short Circuit to GND	Momentary
REF Short Circuit to GND	Momentary
INA Shunt Current	+15mA
Continuous Power Dissipation (T _A = +70°C)	
32-Pin TQFN (derate 21.3mW/°C above +70°C)	1702mW
36-Pin TQFN (derate 26.3mW/°C above +70°C)	2105mW
Operating Temperature Range	-40°C to +85°C
Junction Temperature	+150°C
Storage Temperature Range	-65°C to +150°C
Lead Temperature (soldering, 10s)	+300°C

Stresses beyond those listed under "Absolute Maximum Ratings" may cause permanent damage to the device. These are stress ratings only, and functional operation of the device at these or any other conditions beyond those indicated in the operational sections of the specifications is not implied. Exposure to absolute maximum rating conditions for extended periods may affect device reliability.

ELECTRICAL CHARACTERISTICS

(Circuit of Figure 1, V_{IN} = 12V, both SMPS enabled, V_{CC} = 5V, FSEL = REF, SKIP = GND, V_{LIM} = V_{LDO5}, V_{INA} = 15V, V_{LDOA} = 12V, I_{LDO5} = I_{LDO3} = I_{LDOA} = no load, T_A = 0°C to +85°C, unless otherwise noted. Typical values are at T_A = +25°C.)

PARAMETER	SYMBOL	CONDITIONS	MIN	TYP	MAX	UNITS
INPUT SUPPLIES (Note 1)						
V _{IN} Input Voltage Range	V _{IN}	LDO5 in regulation	6		26	V
		IN = LDO5, V _{OUT5} < 4.43V	4.5		5.5	
V _{IN} Operating Supply Current	I _{IN}	LDO5 switched over to CSL5		15	35	μA
V _{IN} Standby Supply Current	I _{IN(STBY)}	V _{IN} = 6V to 26V, both SMPS off, includes I _{SHDN}		100	170	μA
V _{IN} Shutdown Supply Current	I _{IN(SHDN)}	V _{IN} = 6V to 26V, SHDN = GND		5	17	μA
Quiescent Power Consumption	P _Q	Both SMPS on, FB3 = FB5 = SKIP = GND, V _{CSL3} = 3.5V, V _{CSL5} = 5.3V, V _{INA} = 15V, I _{LDOA} = 0, P _{IN} + P _{CSL3} + P _{CSL5} + P _{INA}		3.5	4.5	mW
V _{CC} Quiescent Supply Current	I _{CC}	Both SMPS on, FB3 = FB5 = GND, V _{CSL3} = 3.5V, V _{CSL5} = 5.3V		1.1	2.1	mA
MAIN SMPS CONTROLLERS						
3.3V Output Voltage in Fixed Mode	V _{OUT3}	V _{IN} = 6V to 26V, SKIP = V _{CC} (Note 2)	3.280	3.33	3.380	V
5V Output Voltage in Fixed Mode	V _{OUT5}	V _{IN} = 6V to 26V, SKIP = V _{CC} (Note 2)	4.975	5.05	5.125	V
Feedback Voltage in Adjustable Mode	V _{FB}	V _{IN} = 6V to 26V, FB3 or FB5, duty factor = 20% to 80% (Note 2)	0.990	1.005	1.020	V
Output-Voltage Adjust Range		Either SMPS	1.0		5.5	V
FB3, FB5 Dual-Mode Threshold			0.1		0.2	V
Feedback Input Leakage Current		V _{FB3} = V _{FB5} = 1.1V	-0.1		+0.1	μA
DC Load Regulation		Either SMPS, SKIP = V _{CC} , I _{LOAD} = 0 to full load		-0.1		%

High-Efficiency, 5x Output, Main Power-Supply Controllers for Notebook Computers

MAX1533/MAX1537

ELECTRICAL CHARACTERISTICS (continued)

(Circuit of Figure 1, $V_{IN} = 12V$, both SMPS enabled, $V_{CC} = 5V$, $FSEL = REF$, $\overline{SKIP} = GND$, $V_{ILIM_} = V_{LDO5}$, $V_{INA} = 15V$, $V_{LDOA} = 12V$, $I_{LDO5} = I_{LDO3} = I_{LDOA} = \text{no load}$, $T_A = 0^{\circ}C \text{ to } +85^{\circ}C$, unless otherwise noted. Typical values are at $T_A = +25^{\circ}C$.)

PARAMETER	SYMBOL	CONDITIONS	MIN	TYP	MAX	UNITS	
Line-Regulation Error		Either SMPS, duty cycle = 10% to 90%		1		%	
Operating Frequency (Note 1)	f_{OSC}	$FSEL = GND$	170	200	230	kHz	
		$FSEL = REF$	270	300	330		
		$FSEL = V_{CC}$	425	500	575		
Maximum Duty Factor (Note 1)	D_{MAX}	$FSEL = GND$	91	93		%	
		$FSEL = REF$	91	93			
		$FSEL = V_{CC}$	91	93			
Minimum On-Time	$t_{ON(MIN)}$	(Note 3)			200	ns	
SMPS3 to SMPS5 Phase Shift		SMPS5 starts after SMPS3		40		%	
				144		Deg	
CURRENT LIMIT							
ILIM_ Adjustment Range			0.5		V_{REF}	V	
Current-Sense Input Range		$CSH_$, $CSL_$	0		5.5	V	
Current-Sense Input Leakage Current		$CSH_$, $V_{CSH_} = 5.5V$	-1		+1	μA	
Current-Limit Threshold (Fixed)	$V_{LIMIT_}$	$V_{CSH_} - V_{CSL_}$, $ILIM_ = V_{CC}$	70	75	80	mV	
Current-Limit Threshold (Adjustable)	$V_{LIMIT_}$	$V_{CSH_} - V_{CSL_}$	$V_{ILIM_} = 2.00V$	170	200	230	mV
			$V_{ILIM_} = 1.00V$	91	100	109	
			$V_{ILIM_} = 0.50V$	42	50	58	
Current-Limit Threshold (Negative)	V_{NEG}	$V_{CSH_} - V_{CSL_}$, $\overline{SKIP} = V_{CC}$, percent of current limit		-120		%	
Current-Limit Threshold (Zero Crossing)	V_{ZX}	$V_{PGND} - V_{LX_}$, $\overline{SKIP} = GND$, $ILIM_ = V_{CC}$		3		mV	
Idle-Mode™ Threshold	V_{IDLE}	$V_{CSH_} - V_{CSL_}$	$ILIM_ = V_{CC}$	10	16	22	mV
			With respect to current-limit threshold (V_{LIMIT})		20		%
ILIM_ Leakage Current		$ILIM3 = ILIM5 = GND \text{ or } V_{CC}$	-0.1		+0.1	μA	
Soft-Start Ramp Time	t_{SS}	Measured from the rising edge of $ON_$ to full scale		512 / f_{OSC}		s	
INTERNAL FIXED LINEAR REGULATORS							
LDO5 Output Voltage	V_{LDO5}	$ON3 = ON5 = GND$, $6V < V_{IN} < 26V$, $0 < I_{LDO5} < 100mA$	4.80	4.95	5.10	V	
LDO5 Undervoltage-Lockout Fault Threshold		Rising edge, hysteresis = 1%	3.75	4.0	4.25	V	
LDO5 Bootstrap Switch Threshold		Rising edge of $CSL5$, hysteresis = 1%	4.41		4.75	V	
LDO5 Bootstrap Switch Resistance		LDO5 to $CSL5$, $V_{CSL5} = 5V$, $I_{LDO5} = 50mA$		0.75	3	Ω	

Idle Mode is a trademark of Maxim Integrated Products, Inc.

High-Efficiency, 5x Output, Main Power-Supply Controllers for Notebook Computers

ELECTRICAL CHARACTERISTICS (continued)

(Circuit of Figure 1, $V_{IN} = 12V$, both SMPS enabled, $V_{CC} = 5V$, $FSEL = REF$, $\overline{SKIP} = GND$, $V_{LIM_} = V_{LDO5}$, $V_{INA} = 15V$, $V_{LDOA} = 12V$, $I_{LDO5} = I_{LDO3} = I_{LDOA} = \text{no load}$, $T_A = 0^{\circ}C \text{ to } +85^{\circ}C$, unless otherwise noted. Typical values are at $T_A = +25^{\circ}C$.)

PARAMETER	SYMBOL	CONDITIONS	MIN	TYP	MAX	UNITS
LDO3 Output Voltage	V_{LDO3}	Standby mode, $6V < V_{IN} < 26V$, $0 < I_{LOAD} < 100mA$	3.20	3.35	3.42	V
LDO3 Bootstrap Switch Threshold		Rising edge of CSL3, hysteresis = 1%	2.83		3.10	V
LDO3 Bootstrap Switch Resistance		LDO3 to CSL3, $V_{CSL3} = 3.2V$, $I_{LDO3} = 50mA$		1	3	Ω
Short-Circuit Current		LDO3 = LDO5 = GND, CSL3 = CSL5 = GND		150	220	mA
Short-Circuit Current (Switched Over to CSL ₋)		LDO3 = LDO5 = GND, $V_{CSL3} > 3.1V$, $V_{CSL5} > 4.7V$	250			mA
AUXILIARY LINEAR REGULATOR (MAX1537 ONLY)						
LDOA Voltage Range	V_{LDOA}		5		23	V
INA Voltage Range	V_{INA}		6		24	V
LDOA Regulation Threshold, Internal Feedback		ADJA = GND, $0 < I_{LDOA} < 120mA$, $V_{INA} > 13V$	11.4	12.0	12.4	V
ADJA Regulation Threshold, External Feedback	V_{ADJA}	$0 < I_{LDOA} < 120mA$, $V_{LDOA} > 5.0V$ and $V_{INA} > V_{LDOA} + 1V$	1.94	2.00	2.06	V
ADJA Dual-Mode Threshold			0.1	0.15	0.2	V
ADJA Leakage Current		$V_{ADJA} = 2.1V$	-0.1		+0.1	μA
LDOA Current Limit		V_{LDOA} forced to $V_{INA} - 1V$, $V_{ADJA} = 1.9V$, $V_{INA} > 6V$	150			mA
Secondary Feedback Regulation Threshold		$V_{INA} - V_{LDOA}$	0.65	0.8	0.95	V
DL Duty Factor		$V_{INA} - V_{LDOA} < 0.7V$, pulse width with respect to switching period		33		%
INA Quiescent Current	I_{INA}	$V_{INA} = 24V$, $I_{LDOA} = \text{no load}$		50	165	μA
INA Shunt Sink Current		$V_{INA} = 28V$	10			mA
INA Leakage Current	$I_{INA(SHDN)}$	$V_{INA} = 5V$, LDOA disabled			30	μA
REFERENCE (REF)						
Reference Voltage	V_{REF}	$V_{CC} = 4.5V \text{ to } 5.5V$, $I_{REF} = 0$	1.985	2.00	2.015	V
Reference Load Regulation		$I_{REF} = -10\mu A \text{ to } +100\mu A$	1.980		2.020	V
REF Lockout Voltage	$V_{REF(UVLO)}$	Rising edge, hysteresis = 350mV		1.95		V
FAULT DETECTION						
Output Overvoltage Trip Threshold		$\overline{OVP} = GND$, with respect to error-comparator threshold	8	11	15	%
Output Overvoltage Fault-Propagation Delay	t_{OVP}	50mV overdrive		10		μs

High-Efficiency, 5x Output, Main Power-Supply Controllers for Notebook Computers

MAX1533/MAX1537

ELECTRICAL CHARACTERISTICS (continued)

(Circuit of Figure 1, $V_{IN} = 12V$, both SMPS enabled, $V_{CC} = 5V$, $FSEL = REF$, $\overline{SKIP} = GND$, $V_{LIM_} = V_{LDO5}$, $V_{INA} = 15V$, $V_{LDOA} = 12V$, $I_{LDO5} = I_{LDO3} = I_{LDOA} = \text{no load}$, $T_A = 0^{\circ}C \text{ to } +85^{\circ}C$, unless otherwise noted. Typical values are at $T_A = +25^{\circ}C$.)

PARAMETER	SYMBOL	CONDITIONS	MIN	TYP	MAX	UNITS
Output Undervoltage-Protection Trip Threshold		With respect to error-comparator threshold	65	70	75	%
Output Undervoltage Fault-Propagation Delay	t_{UVP}	50mV overdrive		10		μs
Output Undervoltage-Protection Blanking Time	t_{BLANK}	From rising edge of $ON_$		6144 / f_{OSC}		s
PGOOD Lower Trip Threshold		With respect to error-comparator threshold, hysteresis = 1%	-14	-10	-7.5	%
PGOOD Propagation Delay	$t_{PGOOD_}$	Falling edge, 50mV overdrive		10		μs
PGOOD Output Low Voltage		$I_{SINK} = 4mA$			0.4	V
PGOOD Leakage Current	$I_{PGOOD_}$	High state, PGOOD forced to 5.5V			1	μA
PGDLY Pullup Current		PGDLY = GND	4	5	6	μA
PGDLY Pulldown Resistance				10	25	Ω
PGDLY Trip Threshold			REF-0.2	REF	REF+0.2	V
Thermal-Shutdown Threshold	T_{SHDN}	Hysteresis = 15°C		+160		$^{\circ}C$
GATE DRIVERS						
DH_ Gate-Driver On-Resistance	R_{DH}	BST_ - LX_ forced to 5V		1.5	5	Ω
DL_ Gate-Driver On-Resistance	R_{DL}	DL_, high state		1.7	5	Ω
		DL_, low state		0.6	3	
DH_ Gate-Driver Source/Sink Current	I_{DH}	DH_ forced to 2.5V, BST_ - LX_ forced to 5V		2		A
DL_ Gate-Driver Source Current	I_{DL}	DL_ forced to 2.5V		1.7		A
DL_ Gate-Driver Sink Current	$I_{DL} (SINK)$	DL_ forced to 2.5V		3.3		A
Dead Time	t_{DEAD}	DL_ rising		35		ns
		DH_ rising		26		
LX_, BST_ Leakage Current		$V_{BST_} = V_{LX_} = 26V$		<2	20	μA
INPUTS AND OUTPUTS						
Logic Input Voltage		\overline{SKIP} , hysteresis = 600mV	High	2.4		V
			Low	0.8		
Fault Enable Logic Input Voltage		\overline{OVP} , \overline{UVP} , ONA	High	0.7 x V_{CC}		V
			Low	0.4		
Logic Input Current		\overline{OVP} , \overline{UVP} , \overline{SKIP} , ONA	-1		+1	μA
\overline{SHDN} Input Trip Level		Rising trip level	1.10	1.6	2.20	V
		Falling trip level	0.96	1	1.04	
$ON_$ Input Voltage		Clear fault level/SMPS off level			0.8	V
		Delay start level (REF)	1.9		2.1	
		SMPS on level	2.4			

High-Efficiency, 5x Output, Main Power-Supply Controllers for Notebook Computers

ELECTRICAL CHARACTERISTICS (continued)

(Circuit of Figure 1, $V_{IN} = 12V$, both SMPS enabled, $V_{CC} = 5V$, $FSEL = REF$, $\overline{SKIP} = GND$, $V_{ILIM_} = V_{LDO5}$, $V_{INA} = 15V$, $V_{LDOA} = 12V$, $I_{LDO5} = I_{LDO3} = I_{LDOA} = \text{no load}$, $T_A = 0^{\circ}C \text{ to } +85^{\circ}C$, unless otherwise noted. Typical values are at $T_A = +25^{\circ}C$.)

PARAMETER	SYMBOL	CONDITIONS	MIN	TYP	MAX	UNITS
FSEL Three-Level Input Logic		High	$V_{CC} - 0.2$			V
		REF	1.7		2.3	
		GND			0.4	
Input Leakage Current		\overline{OVP} , \overline{UVP} , \overline{SKIP} , ONA, ON3, ON5 = GND or V_{CC}	-1		+1	μA
		\overline{SHDN} , 0V or 26V	-1		+1	
		FSEL = GND or V_{CC}	-3		+3	
CSL_ Discharge-Mode On-Resistance	$R_{DISCHARGE}$			10	25	Ω
CSL_ Synchronous-Rectifier Discharge-Mode Turn-On Level			0.2	0.3	0.4	V

ELECTRICAL CHARACTERISTICS

(Circuit of Figure 1, $V_{IN} = 12V$, both SMPS enabled, $V_{CC} = 5V$, $FSEL = REF$, $\overline{SKIP} = GND$, $V_{ILIM_} = V_{LDO5}$, $V_{INA} = 15V$, $V_{LDOA} = 12V$, $I_{LDO5} = I_{LDO3} = I_{LDOA} = \text{no load}$, $T_A = -40^{\circ}C \text{ to } +85^{\circ}C$, unless otherwise noted.) (Note 4)

PARAMETER	SYMBOL	CONDITIONS	MIN	MAX	UNITS
INPUT SUPPLIES (Note 1)					
V_{IN} Input Voltage Range	V_{IN}	LDO5 in regulation	6	26	V
		$I_{IN} = I_{LDO5}$, $V_{OUT5} < 4.4V$	4.5	5.5	
V_{IN} Operating Supply Current	I_{IN}	LDO5 switched over to CSL5, either SMPS on		35	μA
V_{IN} Standby Supply Current	$I_{IN(STBY)}$	$V_{IN} = 6V \text{ to } 26V$, both SMPS off, includes \overline{SHDN}		170	μA
V_{IN} Shutdown Supply Current	$I_{IN(SHDN)}$	$V_{IN} = 6V \text{ to } 26V$		17	μA
Quiescent Power Consumption	P_Q	Both SMPS on, $FB3 = FB5 = \overline{SKIP} = GND$, $V_{CSL3} = 3.5V$, $V_{CSL5} = 5.3V$, $V_{INA} = 15V$, $I_{LDOA} = 0$, $P_{IN} + P_{CSL3} + P_{CSL5} + P_{INA}$		4.5	mW
V_{CC} Quiescent Supply Current	I_{CC}	Both SMPS on, $FB3 = FB5 = GND$, $V_{CSL3} = 3.5V$, $V_{CSL5} = 5.3V$		2.5	mA
MAIN SMPS CONTROLLERS					
3.3V Output Voltage in Fixed Mode	V_{OUT3}	$V_{IN} = 6V \text{ to } 26V$, $\overline{SKIP} = V_{CC}$ (Note 2)	3.28	3.38	V
5V Output Voltage in Fixed Mode	V_{OUT5}	$V_{IN} = 6V \text{ to } 26V$, $\overline{SKIP} = V_{CC}$ (Note 2)	4.975	5.125	V
Feedback Voltage in Adjustable Mode	V_{FB3} , V_{FB5}	$V_{IN} = 6V \text{ to } 26V$, FB3 or FB5, duty factor = 20% to 80% (Note 2)	0.982	1.018	V
Output-Voltage Adjust Range		Either SMPS	1.0	5.5	V
FB3, FB5 Adjustable-Mode Threshold Voltage		Dual-mode comparator	0.1	0.2	V

High-Efficiency, 5x Output, Main Power-Supply Controllers for Notebook Computers

MAX1533/MAX1537

ELECTRICAL CHARACTERISTICS (continued)

(Circuit of Figure 1, $V_{IN} = 12V$, both SMPS enabled, $V_{CC} = 5V$, $FSEL = REF$, $\overline{SKIP} = GND$, $V_{ILIM_} = V_{LDO5}$, $V_{INA} = 15V$, $V_{LDOA} = 12V$, $I_{LDO5} = I_{LDO3} = I_{LDOA} = \text{no load}$, $T_A = -40^{\circ}C \text{ to } +85^{\circ}C$, unless otherwise noted.) (Note 4)

PARAMETER	SYMBOL	CONDITIONS	MIN	MAX	UNITS	
Operating Frequency (Note 1)	f_{OSC}	$FSEL = GND$	170	230	kHz	
		$FSEL = REF$	240	330		
		$FSEL = V_{CC}$	375	575		
Maximum Duty Factor (Note 1)	D_{MAX}	$FSEL = GND$	91		%	
		$FSEL = REF$	91			
		$FSEL = V_{CC}$	91			
Minimum On-Time	$t_{ON(MIN)}$			250	ns	
CURRENT LIMIT						
ILIM_ Adjustment Range			0.5	V_{REF}	V	
Current-Limit Threshold (Fixed)	$V_{LIMIT_}$	$V_{CSH_} - V_{CSL_}$, $ILIM_ = V_{CC}$	67	83	mV	
Current-Limit Threshold (Adjustable)	$V_{LIMIT_}$	$V_{CSH_} - V_{CSL_}$	$V_{ILIM_} = 2.00V$	170	230	mV
			$V_{ILIM_} = 1.00V$	90	110	
			$V_{ILIM_} = 0.50V$	40	60	
INTERNAL FIXED LINEAR REGULATORS						
LDO5 Output Voltage	V_{LDO5}	$ON3 = ON5 = GND$, $6V < V_{IN} < 26V$, $0 < I_{LDO5} < 100mA$	4.8	5.1	V	
LDO5 Undervoltage-Lockout Fault Threshold		Rising edge, hysteresis = 1%	3.75	4.30	V	
LDO3 Output Voltage	V_{LDO3}	Standby mode, $6V < V_{IN} < 28V$, $0 < I_{LOAD} < 100mA$	3.20	3.43	V	
AUXILIARY LINEAR REGULATOR (MAX1537 ONLY)						
LDOA Voltage Range	V_{LDOA}		5	23	V	
INA Voltage Range	V_{INA}		6	24	V	
LDOA Regulation Threshold, Internal Feedback		$ADJA = GND$, $0 < I_{LDOA} < 120mA$, $V_{INA} > 13V$	11.40	12.55	V	
ADJA Regulation Threshold, External Feedback	V_{ADJA}	$0 < I_{LDOA} < 120mA$, $V_{LDOA} > 5.0V$ and $V_{INA} > V_{LDOA} + 1V$	1.94	2.08	V	
ADJA Dual-Mode Threshold		$ADJA$	0.10	0.25	V	
Secondary Feedback Regulation Threshold		$V_{INA} - V_{LDOA}$	0.63	0.97	V	
INA Quiescent Current	I_{INA}	$V_{INA} = 24V$, $I_{LDOA} = \text{no load}$		165	μA	
REFERENCE (REF)						
Reference Voltage	V_{REF}	$V_{CC} = 4.5V \text{ to } 5.5V$, $I_{REF} = 0$	1.97	2.03	V	

High-Efficiency, 5x Output, Main Power-Supply Controllers for Notebook Computers

ELECTRICAL CHARACTERISTICS (continued)

(Circuit of Figure 1, $V_{IN} = 12V$, both SMPS enabled, $V_{CC} = 5V$, $FSEL = REF$, $\overline{SKIP} = GND$, $V_{ILIM_} = V_{LDO5}$, $V_{INA} = 15V$, $V_{LDOA} = 12V$, $I_{LDO5} = I_{LDO3} = I_{LDOA} = \text{no load}$, $T_A = -40^{\circ}C \text{ to } +85^{\circ}C$, unless otherwise noted.) (Note 4)

PARAMETER	SYMBOL	CONDITIONS	MIN	MAX	UNITS
FAULT DETECTION					
Output Overvoltage Trip Threshold		$\overline{OVP} = GND$, with respect to error-comparator threshold	+8	+15	%
Output Undervoltage-Protection Trip Threshold		With respect to error-comparator threshold	+65	+75	%
PGOOD Lower Trip Threshold		With respect to error-comparator threshold, hysteresis = 1%	-14.0	-7.0	%
PGOOD Output Low Voltage		$I_{SINK} = 4mA$		0.4	V
PGDLY Pulldown Resistance				25	Ω
PGDLY Trip Threshold			REF-0.2	REF+0.2	V
GATE DRIVERS					
DH_ Gate-Driver On-Resistance	R_{DH}	BST_ - LX_ forced to 5V		5	Ω
DL_ Gate-Driver On-Resistance	R_{DL}	DL_, high state		5	Ω
		DL_, low state		3	
INPUTS AND OUTPUTS					
Logic Input Voltage		\overline{SKIP} , hysteresis = 600mV	High	2.4	V
			Low	0.8	
Fault Enable Logic Input Voltage		\overline{OVP} , \overline{UVP} , ONA	High	0.7 x V_{CC}	V
			Low	0.4	
\overline{SHDN} Input Trip Level		Rising trip level	1.1	2.2	V
		Falling trip level	0.95	1.05	
ON_ Input Voltage		Clear fault level		0.8	V
		SMPS off level		1.6	
		Delay start level (REF)	1.9	2.1	
		SMPS on level	2.4		
FSEL Three-Level Input Logic		High	$V_{CC} - 0.2$		V
		REF	1.7	2.3	
		GND		0.4	

Note 1: The MAX1533/MAX1537 cannot operate over all combinations of frequency, input voltage (V_{IN}), and output voltage. For large input-to-output differentials and high-switching frequency settings, the required on-time may be too short to maintain the regulation specifications. Under these conditions, a lower operating frequency must be selected. The minimum on-time must be greater than 150ns, regardless of the selected switching frequency. On-time and off-time specifications are measured from 50% point to 50% point at the DH_ pin with LX_ = GND, $V_{BST_} = 5V$, and a 250pF capacitor connected from DH_ to LX_. Actual in-circuit times may differ due to MOSFET switching speeds.

Note 2: When the inductor is in continuous conduction, the output voltage has a DC regulation level lower than the error-comparator threshold by 50% of the ripple. In discontinuous conduction ($\overline{SKIP} = GND$, light load), the output voltage has a DC regulation level higher than the trip level by approximately 1% due to slope compensation.

Note 3: Specifications are guaranteed by design, not production tested.

Note 4: Specifications to $-40^{\circ}C$ are guaranteed by design, not production tested.

High-Efficiency, 5x Output, Main Power-Supply Controllers for Notebook Computers

Typical Operating Characteristics

(MAX1537 circuit of Figure 1, $V_{IN} = 12V$, $LDO5 = V_{CC} = 5V$, $\overline{SKIP} = GND$, $FSEL = REF$, $T_A = +25^\circ C$, unless otherwise noted.)

MAX1533/MAX1537

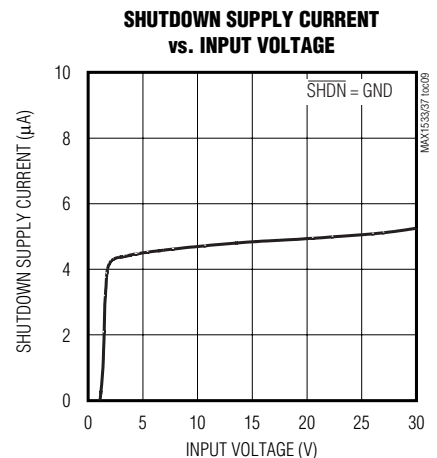
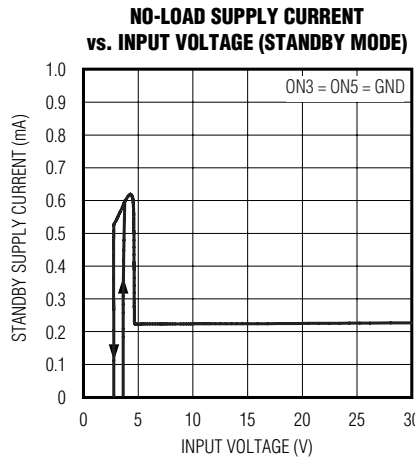
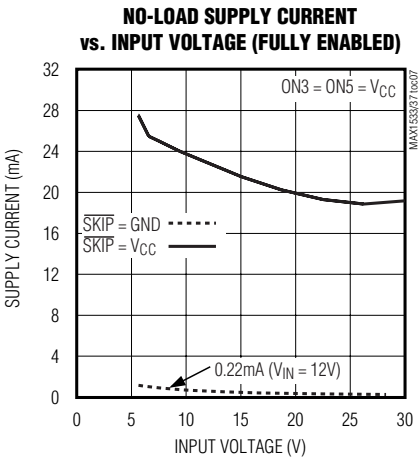
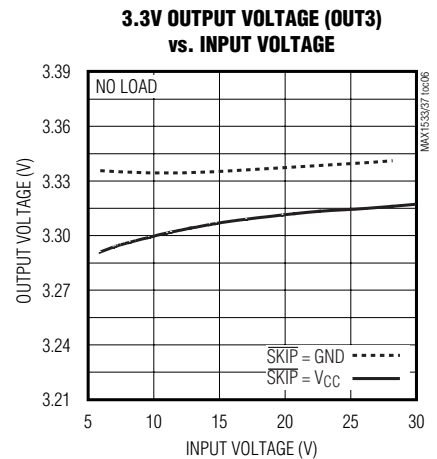
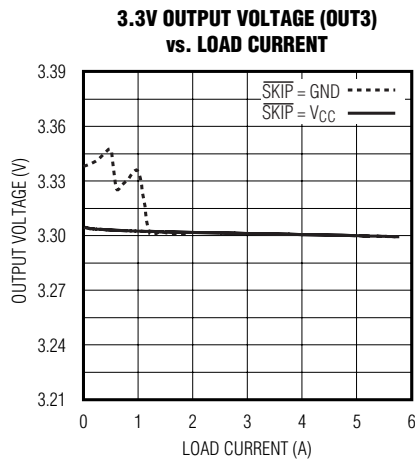
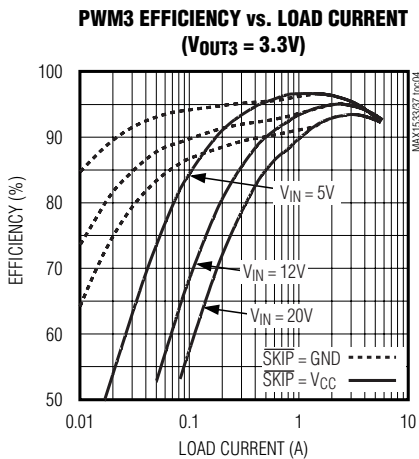
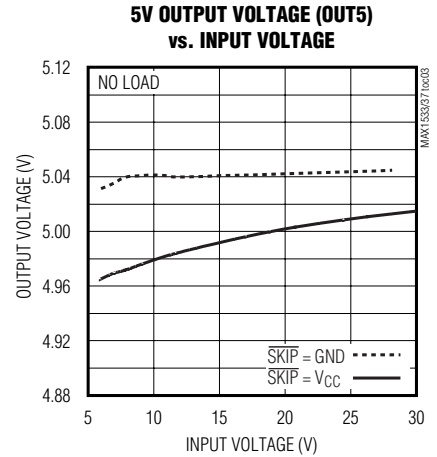
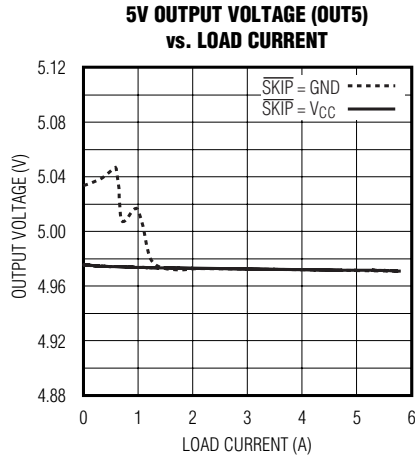
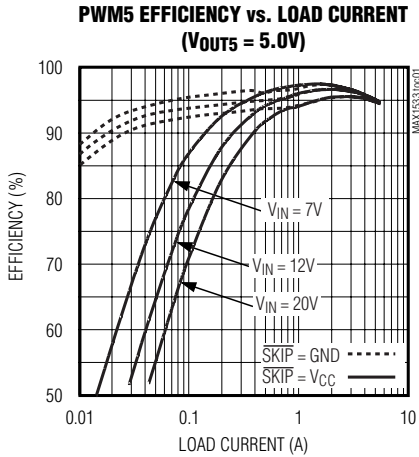

High-Efficiency, 5x Output, Main Power-Supply Controllers for Notebook Computers

Typical Operating Characteristics (continued)

(MAX1537 circuit of Figure 1, $V_{IN} = 12V$, LDO5 = $V_{CC} = 5V$, $\overline{SKIP} = GND$, FSEL = REF, $T_A = +25^\circ C$, unless otherwise noted.)

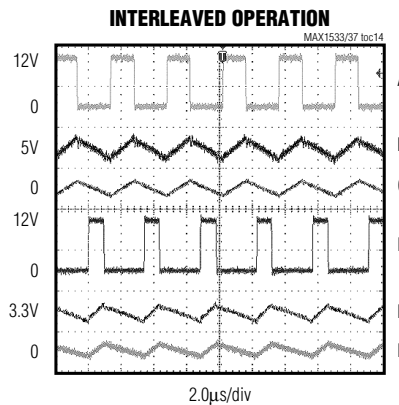
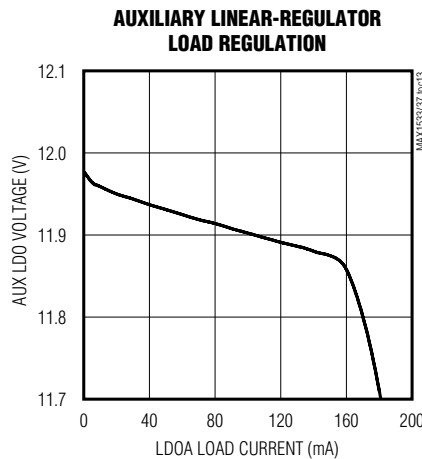
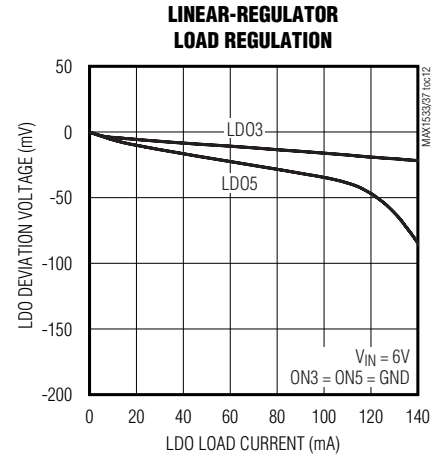
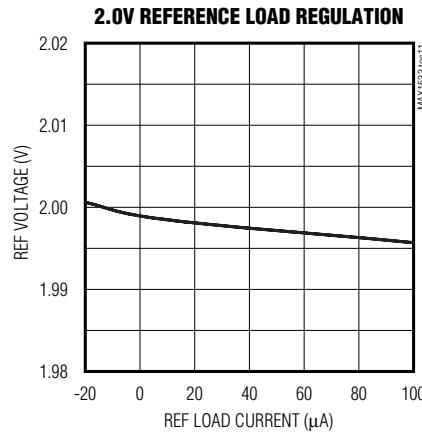
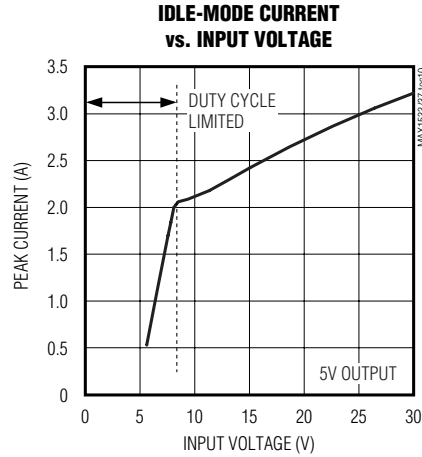

- A. LX5, 10V/div
- B. 5V OUTPUT, 100mV/div
- C. PWM5 INDUCTOR CURRENT, 5A/div
- D. LX3, 10V/div
- E. 3.3V OUTPUT, 100mV/div
- F. PWM3 INDUCTOR CURRENT, 5A/div

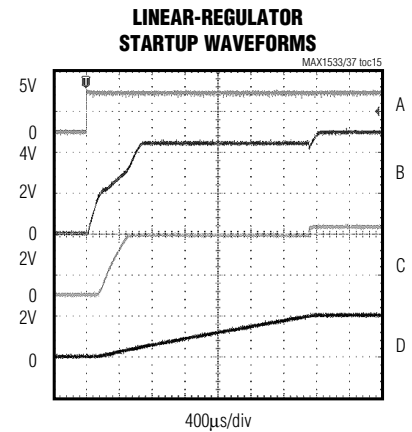

- A. \overline{SHDN} , 5V/div
- B. LDO5, 2V/div
- C. LD03, 2V/div
- D. REF, 2V/div
- 100 Ω LOAD ON LDO5 AND LD03

High-Efficiency, 5x Output, Main Power-Supply Controllers for Notebook Computers

Typical Operating Characteristics (continued)

(MAX1537 circuit of Figure 1, $V_{IN} = 12V$, $LDO5 = V_{CC} = 5V$, $\overline{SKIP} = GND$, $FSEL = REF$, $T_A = +25^\circ C$, unless otherwise noted.)

MAX1533/MAX1537

DELAYED STARTUP WAVEFORM (LIGHT LOAD)

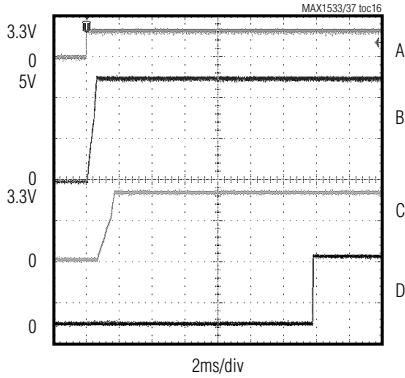

- A. $\overline{ON5}$, 5V/div
 - B. 5V OUTPUT, 2V/div
 - C. 3.3V OUTPUT, 2V/div
 - D. \overline{PGOOD} , 2V/div
- 100 Ω LOAD ON OUT5 AND OUT3, $\overline{ON3} = REF$

STARTUP WAVEFORM (HEAVY LOAD)

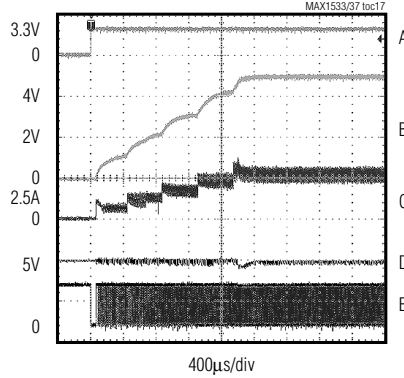

- A. $\overline{ON5}$, 5V/div
 - B. 5V OUTPUT, 2V/div
 - C. INDUCTOR CURRENT, 5A/div
 - D. $LDO5$, 1V/div
 - E. $DL5$, 5V/div
- 1.0 Ω LOAD

SHUTDOWN WAVEFORM (NO LOAD)

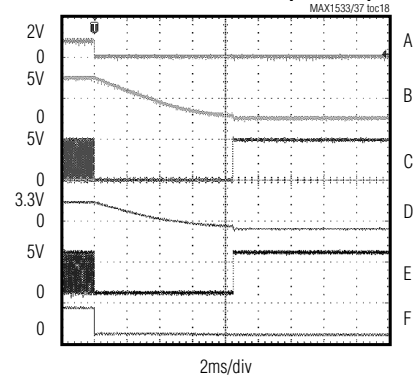

- A. \overline{SHDN} , 5V/div
 - B. 5V OUTPUT, 5V/div
 - C. $DL5$, 5V/div
 - D. 3.3V OUTPUT, 5V/div
 - E. $DL3$, 5V/div
 - F. \overline{PGOOD} , 5V/div
- $\overline{ON3} = \overline{ON5} = V_{CC}$, $\overline{OVP} = GND$

SHUTDOWN WAVEFORM (1 Ω LOAD)

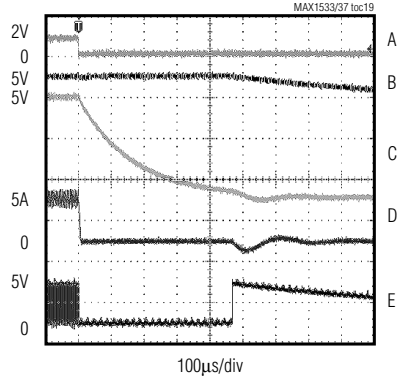

- A. \overline{SHDN} , 5V/div
 - B. $LDO5$, 2V/div
 - C. 5V OUTPUT, 2V/div
 - D. INDUCTOR CURRENT, 5A/div
 - E. $DL5$, 5V/div
- $\overline{ON3} = \overline{ON5} = V_{CC}$, $\overline{OVP} = GND$

5V OUTPUT LOAD TRANSIENT (FORCED-PWM)

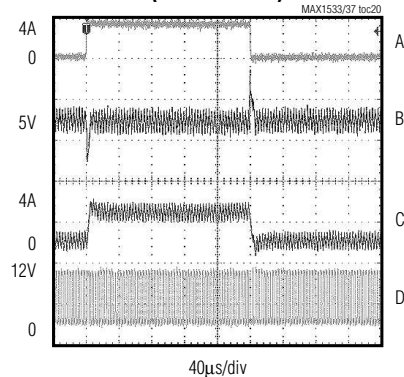

- A. $I_{OUT5} = 0.2A$ TO 4A, 5A/div
 - B. $V_{OUT5} = 5.0V$, 100mV/div
 - C. INDUCTOR CURRENT, 5A/div
 - D. $LX5$, 10V/div
- $\overline{SKIP} = V_{CC}$

3.3V OUTPUT LOAD TRANSIENT (FORCED-PWM)

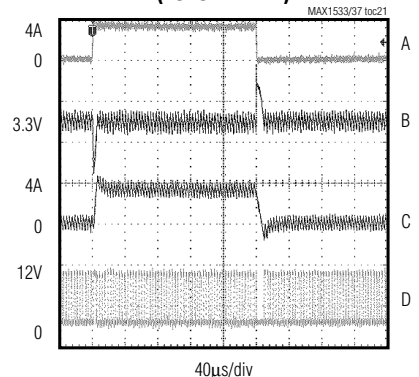

- A. $I_{OUT3} = 0.2A$ TO 4A, 5A/div
 - B. $V_{OUT3} = 3.3V$, 100mV/div
 - C. INDUCTOR CURRENT, 5A/div
 - D. $LX3$, 10V/div
- $\overline{SKIP} = V_{CC}$

High-Efficiency, 5x Output, Main Power-Supply Controllers for Notebook Computers

Typical Operating Characteristics (continued)

(MAX1537 circuit of Figure 1, $V_{IN} = 12V$, LDO5 = $V_{CC} = 5V$, $\overline{SKIP} = GND$, FSEL = REF, $T_A = +25^\circ C$, unless otherwise noted.)

3.3V OUTPUT LOAD TRANSIENT (PULSE SKIPPING)

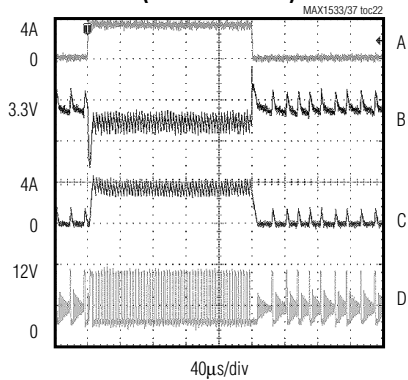

- A. $I_{OUT3} = 0.2A$ TO $4A$, 5A/div
 - B. $V_{OUT3} = 3.3V$, 100mV/div
 - C. INDUCTOR CURRENT, 5A/div
 - D. LX3, 10V/div
- $SKIP = GND$

OUTPUT OVERLOAD (UVP ENABLED)

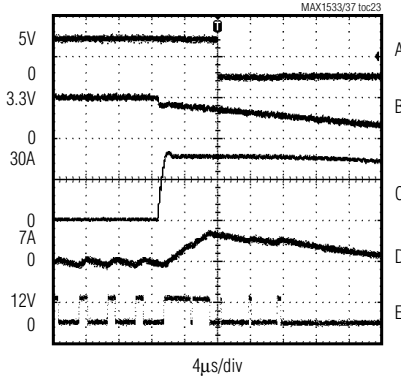

- A. PG00D2, 5V/div
- B. 3.3V OUTPUT, 3.3V/div
- C. LOAD (0 TO 30A), 20A/div
- D. INDUCTOR CURRENT, 10A/div
- E. LX3, 20V/div

LDO5 LOAD TRANSIENT

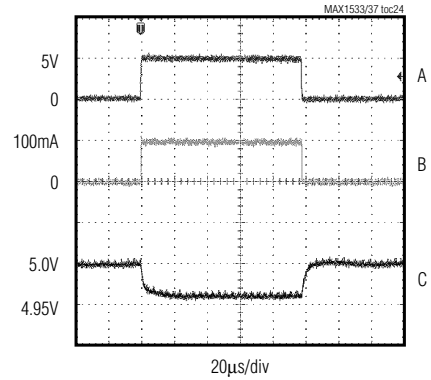

- A. CONTROL SIGNAL, 5V/div
 - B. $I_{LDO5} = 1mA$ TO $100mA$, 100mA/div
 - C. LDO5, 50mV/div
- $ON3 = ON5 = GND$

LDO5 LINE TRANSIENT

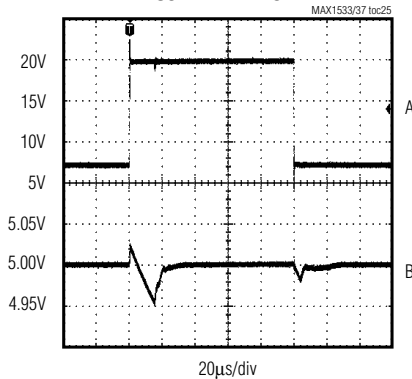

- A. INPUT VOLTAGE ($V_{IN} = 7V$ TO $20V$), 5V/div
 - B. LDO5 OUTPUT VOLTAGE, 50mV/div
- $ON3 = ON5 = GND$, $I_{LDO5} = 20mA$

AUXILIARY LINEAR-REGULATOR LOAD TRANSIENT

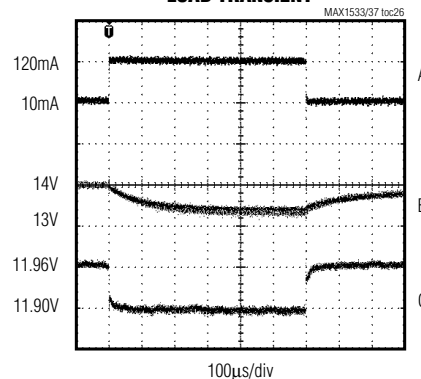

- A. $I_{LDOA} = 10mA$ TO $100mA$, 100mA/div
 - B. INA, 1V/div
 - C. LDOA, 50mV/div
- INA = VOLTAGE GENERATED BY SECONDARY TRANSFORMER WINDING

High-Efficiency, 5x Output, Main Power-Supply Controllers for Notebook Computers

Pin Description

MAX1533/MAX1537

PIN		NAME	FUNCTION
MAX1533	MAX1537		
—	1	ADJA	Auxiliary Feedback Input. Connect a resistive voltage-divider from LDOA to analog ground to adjust the auxiliary linear-regulator output voltage. ADJA regulates at 2V. Connect ADJA to GND for nominal 12V output using internal feedback.
1	2	ON5	5V SMPS Enable Input. The 5V SMPS is enabled if ON5 is greater than the SMPS on level and disabled if ON5 is less than the SMPS off level. If ON5 is connected to REF, the 5V SMPS starts after the 3.3V SMPS reaches regulation (delay start). Drive ON5 below the clear fault level to reset the fault latches.
2	3	ON3	3.3V SMPS Enable Input. The 3.3V SMPS is enabled if ON3 is greater than the SMPS on level and disabled if ON3 is less than the SMPS off level. If ON3 is connected to REF, the 3.3V SMPS starts after the 5V SMPS reaches regulation (delay start). Drive ON3 below the clear fault level to reset the fault latches.
—	4	ONA	LDOA Enable Input. When ONA is low, LDOA is high impedance and the secondary winding control is off. When ONA is high, LDOA is on. Connect to LDO3, LDO5, CSL3, CSL5, or other output for desired automatic startup sequencing.
3	5	FSEL	Frequency-Select Input. This three-level logic input sets the controller's switching frequency. Connect to GND, REF, or V _{CC} to select the following typical switching frequencies: V _{CC} = 500kHz, REF = 300kHz, GND = 200kHz
4	6	ILIM3	3.3V SMPS Peak Current-Limit Threshold Adjustment. The current-limit threshold defaults to 75mV if ILIM3 is connected to V _{CC} . In adjustable mode, the current-limit threshold across CSH3 and CSL3 is precisely 1/10th the voltage seen at ILIM3 over a 500mV to 2.0V range. The logic threshold for switchover to the 75mV default value is approximately V _{CC} - 1V.
5	7	ILIM5	5V SMPS Peak Current-Limit Threshold. The current-limit threshold defaults to 75mV if ILIM5 is connected to V _{CC} . In adjustable mode, the current-limit threshold across CSH5 and CSL5 is precisely 1/10th the voltage seen at ILIM5 over a 500mV to 2.0V range. The logic threshold for switchover to the 75mV default value is approximately V _{CC} - 1V.
6	8	REF	2.0V Reference Voltage Output. Bypass REF to analog ground with a 0.1μF or greater ceramic capacitor. The reference can source up to 100μA for external loads. Loading REF degrades output-voltage accuracy according to the REF load-regulation error. The reference shuts down when $\overline{\text{SHDN}}$ is low.
7	9	GND	Analog Ground. Connect the backside pad to GND.
8	10	V _{CC}	Analog Supply Input. Connect to the system supply voltage (+4.5V to +5.5V) through a series 20Ω resistor. Bypass V _{CC} to analog ground with a 1μF or greater ceramic capacitor.
9	11	PGDLY	Power-Good One-Shot Delay. Place a timing capacitor on PGDLY to delay PGOOD going high. PGDLY has a 5μA pullup current and a 10Ω pulldown. The pulldown is activated when power is not good. When power is good, the pulldown is shut off and the 5μA pullup is activated. When PGDLY crosses REF, PGOOD is enabled.

High-Efficiency, 5x Output, Main Power-Supply Controllers for Notebook Computers

Pin Description (continued)

PIN		NAME	FUNCTION
MAX1533	MAX1537		
10	12	PGOOD	Open-Drain Power-Good Output. PGOOD is low if either output is more than 10% (typ) below the normal regulation point, during soft-start, and in shutdown. PGOOD is delayed on the rising edge by the PGDLY one-shot timer. PGOOD becomes high impedance when both SMPS outputs are in regulation.
11	13	\overline{UVP}	Undervoltage Fault-Protection Control. Connect \overline{UVP} to GND to select the default overvoltage threshold of 70% of nominal. Connect to V _{CC} to disable undervoltage protection and clear the undervoltage fault latch.
12	14	DH3	High-Side Gate-Driver Output for 3.3V SMPS. DH3 swings from LX3 to BST3.
13	15	BST3	Boost Flying-Capacitor Connection for 3.3V SMPS. Connect to an external capacitor and diode as shown in Figure 6. An optional resistor in series with BST3 allows the DH3 pullup current to be adjusted.
14	16	LX3	Inductor Connection for 3.3V SMPS. Connect LX3 to the switched side of the inductor. LX3 serves as the lower supply rail for the DH3 high-side gate driver.
15	17	\overline{OVP}	Overvoltage Fault-Protection Control. Connect \overline{OVP} to GND to select the default overvoltage threshold of +11% above nominal. Connect to V _{CC} to disable overvoltage protection and clear the overvoltage fault latch.
16	18	CSH3	Positive Current-Sense Input for 3.3V SMPS. Connect to the positive terminal of the current-sense element. Figure 9 describes two different current-sensing options.
17	19	CSL3	Negative Current-Sense Input for 3.3V SMPS. Connect to the negative terminal of the current-sense element. Figure 9 describes two different current-sensing options. CSL3 also serves as the bootstrap input for LDO3.
18	20	FB3	Feedback Input for 3.3V SMPS. Connect to GND for fixed 3.3V output. In adjustable mode, FB3 regulates to 1V.
19	21	LDO3	3.3V Internal Linear-Regulator Output. Bypass with 2.2 μ F (min) (1 μ F/20mA). Provides 100mA (min). Power is taken from LDO5. If CSL3 is greater than 3V, the linear regulator shuts down and LDO3 connects to CSL3 through a 1 Ω switch rated for loads up to 200mA.
20	22	DL3	Low-Side Gate-Driver Output for 3.3V SMPS. DL3 swings from PGND to LDO5.
21	23	PGND	Power Ground
22	24	DL5	Low-Side Gate-Driver Output for 5V SMPS. DL5 swings from PGND to LDO5.
23	25	LDO5	5V Internal Linear-Regulator Output. Bypass with 2.2 μ F (min) (1 μ F/20mA). Provides power for the DL_ low-side gate drivers, the DH_ high-side drivers through the BST diodes, the PWM controller, logic, and reference through the V _{CC} pin, as well as the LDO3 internal 3.3V linear regulator. Provides 100mA (min) for external loads (+25mA for gate drivers). If CSL5 is greater than 4.5V, the linear regulator shuts down and LDO5 connects to CSL5 through a 0.75 Ω switch rated for loads up to 200mA.
24	26	FB5	Feedback Input for 5V SMPS. Connect to GND for fixed 5V output. In adjustable mode, FB5 regulates to 1V.

High-Efficiency, 5x Output, Main Power-Supply Controllers for Notebook Computers

Pin Description (continued)

MAX1533/MAX1537

PIN		NAME	FUNCTION
MAX1533	MAX1537		
25	27	CSL5	Negative Current-Sense Input for 5V SMPS. Connect to the negative terminal of the current-sense element. Figure 9 describes two different current-sensing options. CSL5 also serves as the bootstrap input for LDO5.
26	28	CSH5	Positive Current-Sense Input for 5V SMPS. Connect to the positive terminal of the current-sense element. Figure 9 describes two different current-sensing options.
27	29	IN	Input of the Startup Circuitry and the LDO5 Internal 5V Linear Regulator. Bypass to PGND with 0.22 μ F close to the IC.
28	30	LX5	Inductor Connection for 5V SMPS. Connect LX5 to the switched side of the inductor. LX5 serves as the lower supply rail for the DH5 high-side gate driver.
29	31	BST5	Boost Flying-Capacitor Connection for 5V SMPS. Connect to an external capacitor and diode as shown in Figure 6. An optional resistor in series with BST5 allows the DH5 pullup current to be adjusted.
30	32	DH5	High-Side Gate-Driver Output for 5V SMPS. DH5 swings from LX5 to BST5.
31	33	$\overline{\text{SKIP}}$	Pulse-Skipping Control Input. Connect to V _{CC} for low-noise forced-PWM mode. Connect to GND for high-efficiency pulse-skipping mode at light loads.
32	34	$\overline{\text{SHDN}}$	Shutdown Control Input. The device enters its 5 μ A supply-current shutdown mode if V _{SHDN} is less than the $\overline{\text{SHDN}}$ input falling-edge trip level and does not restart until V _{SHDN} is greater than the $\overline{\text{SHDN}}$ input rising-edge trip level. Connect $\overline{\text{SHDN}}$ to V _{IN} for automatic startup. $\overline{\text{SHDN}}$ can be connected to V _{IN} through a resistive voltage-divider to implement a programmable undervoltage lockout.
—	35	INA	Supply Voltage Input for the Auxiliary LDOA Linear Regulator. INA is clamped with an internal shunt to 26V.
—	36	LDOA	Adjustable (12V Nominal) 150mA Auxiliary Linear-Regulator Output. Input supply comes from INA. Bypass LDOA to GND with 2.2 μ F (min) (1 μ F/20mA). Secondary feedback threshold is set at INA - LDOA = 0.8V, and triggers the DL5 on the 5V SMPS only. ONA high enables regulator output and secondary regulation. PGOOD is not affected by the state of LDOA.

High-Efficiency, 5x Output, Main Power-Supply Controllers for Notebook Computers

Table 1. Component Selection for Standard Applications

COMPONENT	5A/300kHz	5A/500kHz
Input Voltage	$V_{IN} = 7V$ to 24V	$V_{IN} = 7V$ to 24V
$C_{IN_}$, Input Capacitor	(2) 10 μ F, 25V Taiyo Yuden TMK432BJ106KM	(2) 10 μ F, 25V Taiyo Yuden TMK432BJ106KM
C_{OUT5} , Output Capacitor	150 μ F, 6.3V, 40m Ω , low-ESR capacitor Sanyo 6TPB150ML	150 μ F, 6.3V, 40m Ω , low-ESR capacitor Sanyo 6TPB150ML
C_{OUT3} , Output Capacitor	220 μ F, 4V, 40m Ω , low-ESR capacitor Sanyo 4TPB220ML	220 μ F, 4V, 40m Ω , low-ESR capacitor Sanyo 4TPB220ML
$N_{H_}$ High-Side MOSFET	Fairchild Semiconductor FDS6612A International Rectifier IRF7807V	Fairchild Semiconductor FDS6612A International Rectifier IRF7807V
$N_{L_}$ Low-Side MOSFET	Fairchild Semiconductor FDS6670S International Rectifier IRF7807VD1	Fairchild Semiconductor FDS6670S International Rectifier IRF7807VD1
$D_{L_}$ Schottky Rectifier (if needed)	2A, 30V, 0.45V $_f$ Nihon EC21QS03L	2A, 30V, 0.45V $_f$ Nihon EC21QS03L
Inductor/Transformer	T1 = 6.8 μ H, 1:2 turns Sumida 4749-T132 L1 = 5.8 μ H, 8.6A Sumida CDRH127-5R8NC	3.9 μ H Sumida CDRH124-3R9NC
Rcs	10m Ω \pm 1%, 0.5W resistor IRC LR2010-01-R010F or Dale WSL-2010-R010F	10m Ω \pm 1%, 0.5W resistor IRC LR2010-01-R010F or Dale WSL-2010-R010F

Table 2. Component Suppliers

SUPPLIER	WEBSITE
AVX	www.avx.com
Central Semiconductor	www.centralsemi.com
Coilcraft	www.coilcraft.com
Coiltronics	www.coiltronics.com
Fairchild Semiconductor	www.fairchildsemi.com
International Rectifier	www.irf.com
Kemet	www.kemet.com

SUPPLIER	WEBSITE
Panasonic	www.panasonic.com/industrial
Sanyo	www.secc.co.jp
Sumida	www.sumida.com
Taiyo Yuden	www.t-yuden.com
TDK	www.component.tdk.com
TOKO	www.tokoam.com
Vishay (Dale, Siliconix)	www.vishay.com

Detailed Description

The MAX1533/MAX1537 standard application circuit (Figure 1) generates the 5V/5A and 3.3V/5A typical of the main supplies in a notebook computer. The input supply range is 7V to 24V. See Table 1 for component selections and Table 2 for component manufacturers.

The MAX1533/MAX1537 contain two interleaved fixed-frequency step-down controllers designed for low-voltage power supplies. The optimal interleaved architecture guarantees out-of-phase operation, reducing the input capacitor ripple. Two internal LDOs generate the keep-alive 5V and 3.3V power. The MAX1537 has an auxiliary LDO that can be configured to the preset 12V output or an adjustable output.

Fixed Linear Regulators (LDO5 and LDO3)

Two internal linear regulators produce preset 5V (LDO5) and 3.3V (LDO3) low-power outputs. LDO5 powers LDO3, the gate drivers for the external MOSFETs, and provides the bias supply (V_{CC}) required for the SMPS analog control, reference, and logic blocks. LDO5 supplies at least 100mA for external and internal loads, including the MOSFET gate drive, which typically varies from 5mA to 50mA, depending on the switching frequency and external MOSFETs selected. LDO3 also supplies at least 100mA for external loads. Bypass LDO5 and LDO3 with a 2.2 μ F or greater output capacitor, using an additional 1.0 μ F per 20mA of internal and external load.

High-Efficiency, 5x Output, Main Power-Supply Controllers for Notebook Computers

MAX1533/MAX1537

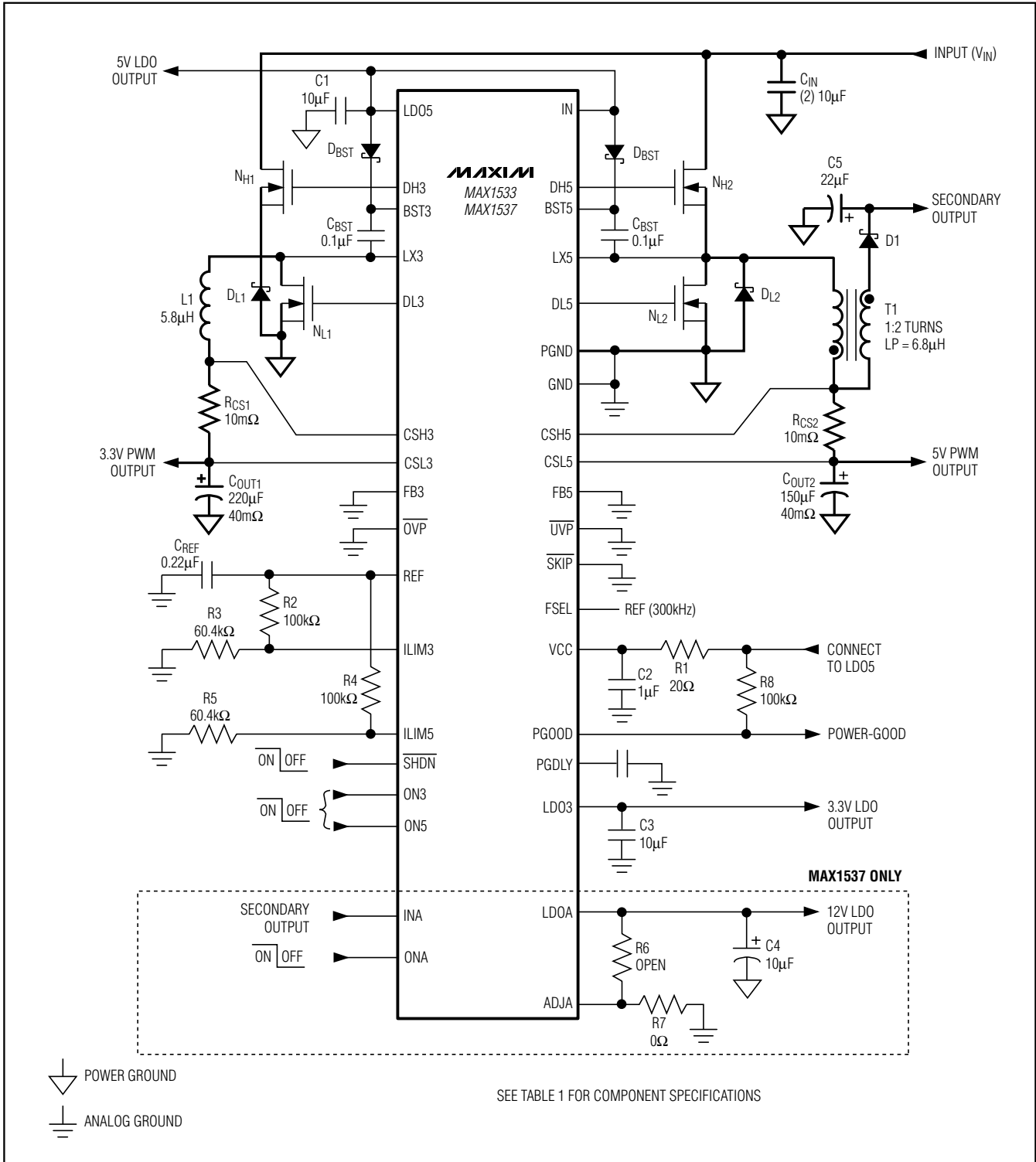

Figure 1. MAX1533/MAX1537 Standard Application Circuit

High-Efficiency, 5x Output, Main Power-Supply Controllers for Notebook Computers

SMPS to LDO Bootstrap Switchover

When the 5V main output voltage is above the LDO5 bootstrap-switchover threshold, an internal 0.75Ω (typ) p-channel MOSFET shorts CSL5 to LDO5 while simultaneously shutting down the LDO5 linear regulator. Similarly, when the 3.3V main output voltage is above the LDO3 bootstrap-switchover threshold, an internal 1Ω (typ) p-channel MOSFET shorts CSL3 to LDO3 while simultaneously shutting down the LDO3 linear regulator. These actions bootstrap the device, powering the internal circuitry and external loads from the output SMPS voltages, rather than through linear regulators from the battery. Bootstrapping reduces power dissipation due to gate charge and quiescent losses by providing power from a 90%-efficient switch-mode source, rather than from a much-less-efficient linear regulator. The output current limit increases to 200mA when the LDO_ outputs are switched over.

SMPS 5V Bias Supply (LDO5 and Vcc)

The A switch-mode power supplies (SMPS) require a 5V bias supply in addition to the high-power input supply (battery or AC adapter). This 5V bias supply is generated by the MAX1533/MAX1537s' internal 5V linear regulator (LDO5). This bootstrapped LDO allows the MAX1533/MAX1537 to power-up independently. The gate-driver input supply is connected to the fixed 5V linear-regulator output (LDO5). Therefore, the 5V LDO supply must provide V_{CC} (PWM controller) and the gate-drive power, so the maximum supply current required is:

$$\begin{aligned} I_{\text{BIAS}} &= I_{\text{CC}} + f_{\text{SW}} (Q_{\text{G(LOW)}} + Q_{\text{G(HIGH)}}) \\ &= 5\text{mA to } 50\text{mA (typ)} \end{aligned}$$

where I_{CC} is 1mA (typ), f_{SW} is the switching frequency, and $Q_{\text{G(LOW)}}$ and $Q_{\text{G(HIGH)}}$ are the MOSFET data sheet's total gate-charge specification limits at $V_{\text{GS}} = 5\text{V}$.

Reference (REF)

The 2V reference is accurate to $\pm 1\%$ over temperature and load, making REF useful as a precision system reference. Bypass REF to GND with a $0.22\mu\text{F}$ or greater ceramic capacitor. The reference sources up to $100\mu\text{A}$ and sinks $10\mu\text{A}$ to support external loads. If highly accurate specifications ($\pm 0.5\%$) are required for the main SMPS output voltages, the reference should not be loaded. Loading the reference reduces the LDO5, LDO3, OUT5, and OUT3 output voltages slightly because of the reference load-regulation error.

System Enable/Shutdown ($\overline{\text{SHDN}}$)

Drive $\overline{\text{SHDN}}$ below the precise $\overline{\text{SHDN}}$ input falling-edge trip level to place the MAX1533/MAX1537 in their low-power shutdown state. The MAX1533/MAX1537 consume only $5\mu\text{A}$ of quiescent current while in shutdown mode. When shutdown mode activates, the reference turns off, making the threshold to exit shutdown less accurate. To guarantee startup, drive $\overline{\text{SHDN}}$ above 2.2V ($\overline{\text{SHDN}}$ input rising-edge trip level). For automatic shutdown and startup, connect $\overline{\text{SHDN}}$ to V_{IN} . The accurate 1V falling-edge threshold on $\overline{\text{SHDN}}$ can be used to detect a specific input-voltage level and shut the device down. Once in shutdown, the 1.6V rising-edge threshold activates, providing sufficient hysteresis for most applications.

SMPS Detailed Description

SMPS POR, UVLO, and Soft-Start

Power-on reset (POR) occurs when V_{CC} rises above approximately 1V, resetting the undervoltage, overvoltage, and thermal-shutdown fault latches. The POR circuit also ensures that the low-side drivers are pulled low if OVP is disabled ($\overline{\text{OVP}} = V_{\text{CC}}$), or driven high if OVP is enabled ($\overline{\text{OVP}} = \text{GND}$) until the SMPS controllers are activated.

The V_{CC} input undervoltage-lockout (UVLO) circuitry inhibits switching if the 5V bias supply (LDO5) is below the 4V input UVLO threshold. Once the 5V bias supply (LDO5) rises above this input UVLO threshold and the controllers are enabled, the SMPS controllers start switching and the output voltages begin to ramp up using soft-start.

The internal digital soft-start gradually increases the internal current-limit level during startup to reduce the input surge currents. The MAX1533/MAX1537 divide the soft-start period into five phases. During the first phase, each controller limits its current limit to only 20% of its full current limit. If the output does not reach regulation within 128 clock cycles ($1 / f_{\text{OSC}}$), soft-start enters the second phase and the current limit is increased by another 20%. This process repeats until the maximum current limit is reached after 512 clock cycles ($1 / f_{\text{OSC}}$) or when the output reaches the nominal regulation voltage, whichever occurs first (see the startup waveforms in the *Typical Operating Characteristics*).

High-Efficiency, 5x Output, Main Power-Supply Controllers for Notebook Computers

MAX1533/MAX1537

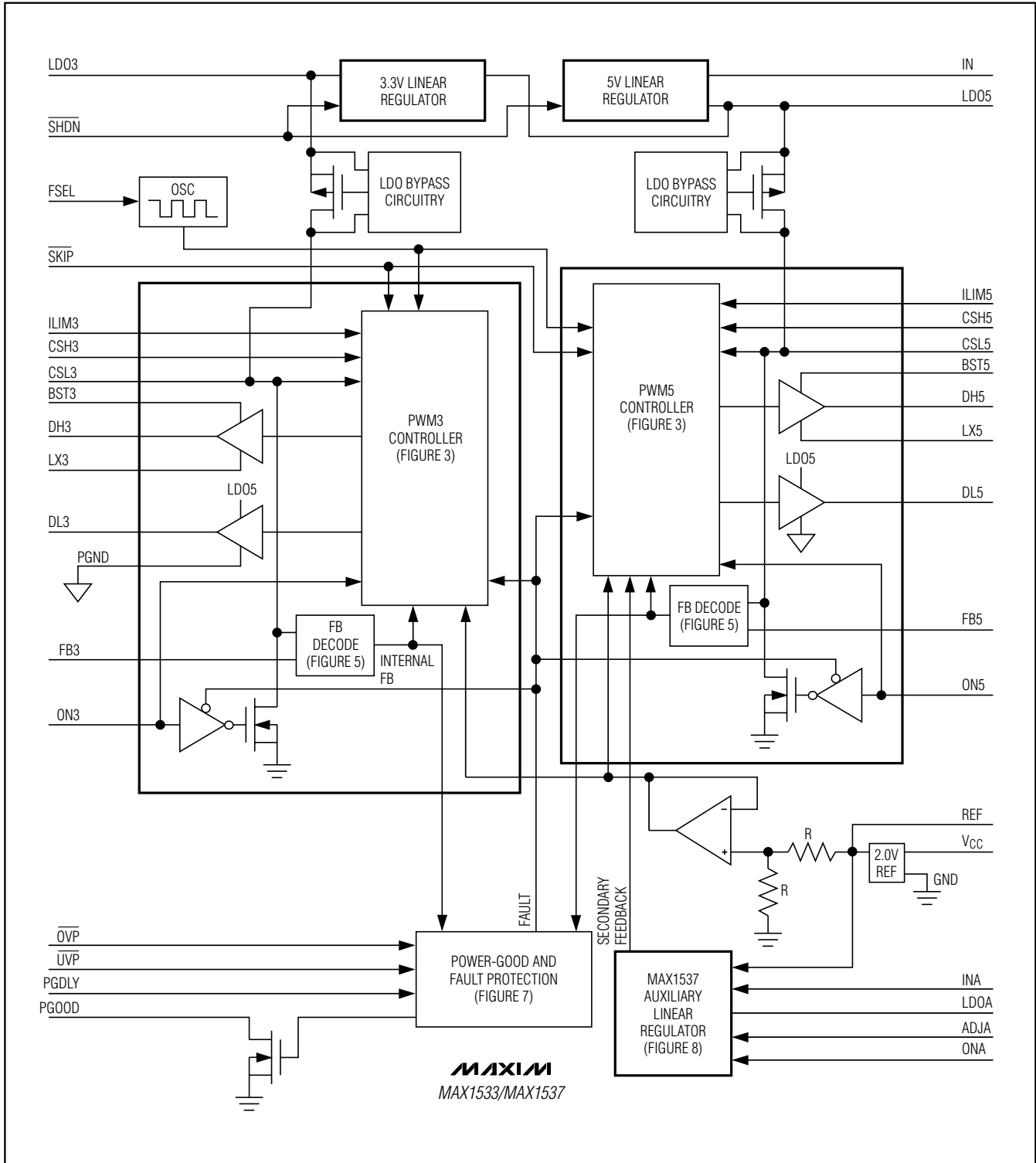

Figure 2. MAX1533/MAX1537 Functional Diagram

High-Efficiency, 5x Output, Main Power-Supply Controllers for Notebook Computers

Table 3. Operating Modes

MODE	INPUTS*			OUTPUTS			
	SHDN	ON5	ON3	LDO5	LDO3	5V SMPS	3V SMPS
Shutdown Mode	LOW	X	X	OFF	OFF	OFF	OFF
Standby Mode	HIGH	LOW	LOW	ON	ON	OFF	OFF
Normal Operation	HIGH	HIGH	HIGH	ON	ON	ON	ON
3.3V SMPS Active	HIGH	LOW	HIGH	ON	ON	OFF	ON
5V SMPS Active	HIGH	HIGH	LOW	ON	ON	ON	OFF
Normal Operation (Delayed 5V SMPS Startup)	HIGH	REF	HIGH	ON	ON	ON Power-up after 3.3V SMPS is in regulation	ON
Normal Operation (Delayed 3.3V SMPS Startup)	HIGH	HIGH	REF	ON	ON	ON	ON Power-up after 5V SMPS is in regulation

*SHDN is an accurate, low-voltage logic input with 1V falling-edge threshold voltage and 1.6V rising-edge threshold voltage. ON3 and ON5 are 3-level CMOS logic inputs, a logic-low voltage is less than 0.8V, a logic-high voltage is greater than 2.4V, and the middle logic level is between 1.9V and 2.1V (see the Electrical Characteristics table).

SMPS Enable Controls (ON3, ON5)

ON3 and ON5 control SMPS power-up sequencing. ON3 or ON5 rising above 2.4V enables the respective outputs. ON3 or ON5 falling below 1.6V disables the respective outputs. Driving ON_n below 0.8V clears the overvoltage, undervoltage, and thermal fault latches.

SMPS Power-Up Sequencing

Connecting ON3 or ON5 to REF forces the respective outputs off while the other output is below regulation and starts after that output regulates. The second SMPS remains on until the first SMPS turns off, the device shuts down, a fault occurs, or LDO5 goes into undervoltage lockout. Both supplies begin their power-down sequence immediately when the first supply turns off.

Output Discharge (Soft-Shutdown)

When output discharge is enabled (OVP pulled low) and the switching regulators are disabled—by transitions into standby or shutdown mode, or when an output undervoltage fault occurs—the controller discharges both outputs through internal 12Ω switches, until the output voltages decrease to 0.3V. This slowly discharges the output capacitance, providing a soft-damped shutdown response. This eliminates the slightly negative output voltages caused by quickly discharging the output through the inductor and low-side MOSFET. When an SMPS output discharges to

0.3V, its low-side driver (DL₋) is forced high, clamping the respective SMPS output to GND. The reference remains active to provide an accurate threshold and to provide overvoltage protection. Both SMPS controllers contain separate soft-shutdown circuits.

When output discharge is disabled ($\overline{\text{OVP}} = V_{CC}$), the low-side drivers (DL₋) and high-side drivers (DH₋) are both pulled low, forcing LX into a high-impedance state. Since the outputs are not actively discharged by the SMPS controllers, the output-voltage discharge rate is determined only by the output capacitance and load current.

Fixed-Frequency, Current-Mode PWM Controller

The heart of each current-mode PWM controller is a multi-input, open-loop comparator that sums two signals: the output-voltage error signal with respect to the reference voltage and the slope-compensation ramp (Figure 3). The MAX1533/MAX1537 use a direct-summing configuration, approaching ideal cycle-to-cycle control over the output voltage without a traditional error amplifier and the phase shift associated with it. The MAX1533/MAX1537 use a relatively low loop gain, allowing the use of low-cost output capacitors. The low loop gain results in the -0.1% typical load-regulation error and helps reduce the output capacitor size and cost by shifting the unity-gain crossover frequency to a lower level.

High-Efficiency, 5x Output, Main Power-Supply Controllers for Notebook Computers

MAX1533/MAX1537

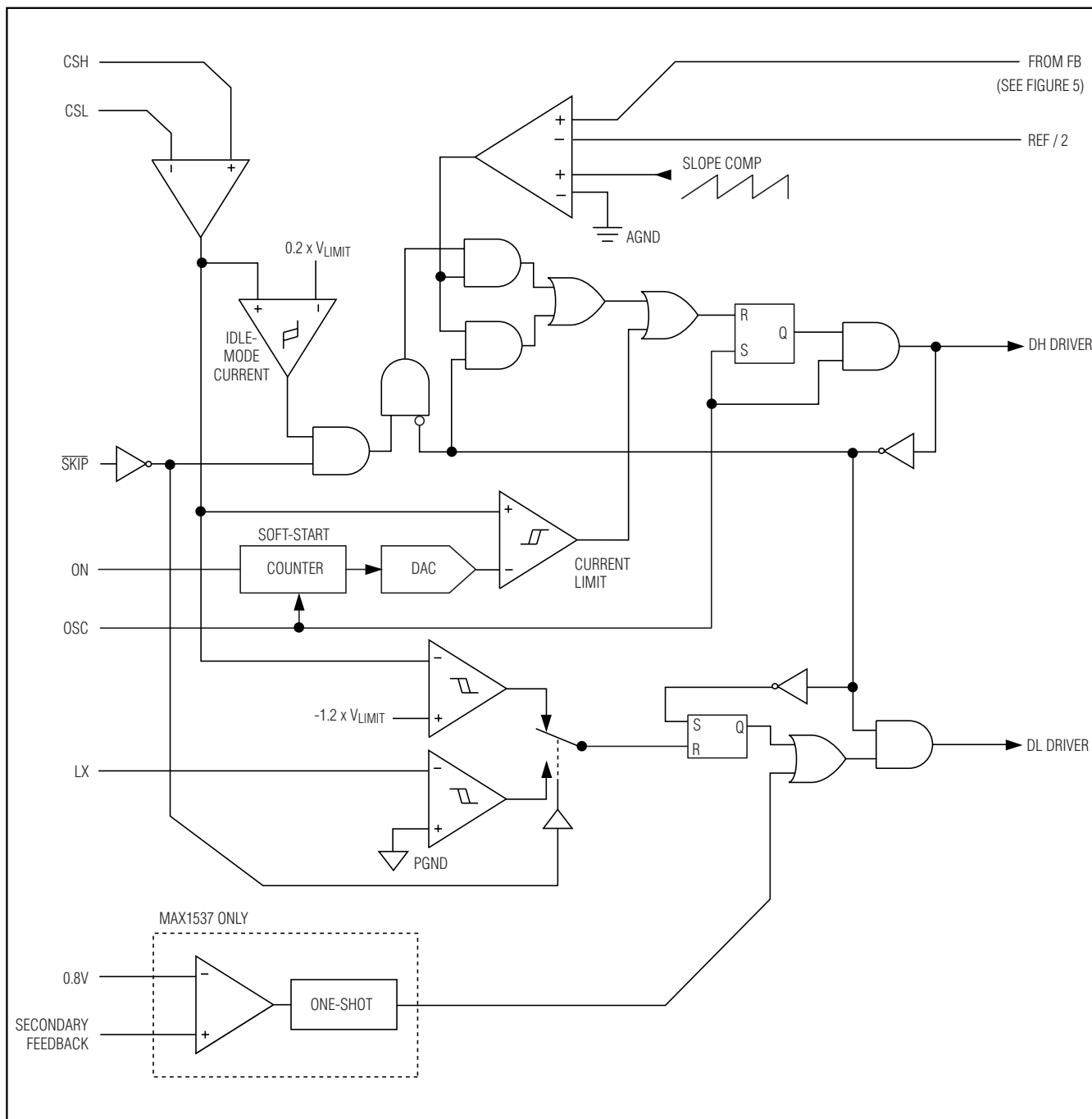

Figure 3: PWM-Controller Functional Diagram

High-Efficiency, 5x Output, Main Power-Supply Controllers for Notebook Computers

Frequency Selection (FSEL)

The FSEL input selects the PWM-mode switching frequency. Table 4 shows the switching frequency based on FSEL connection. High-frequency (500kHz) operation optimizes the application for the smallest component size, trading off efficiency due to higher switching losses. This may be acceptable in ultra-portable devices where the load currents are lower. Low-frequency (200kHz) operation offers the best overall efficiency at the expense of component size and board space.

Forced-PWM Mode

The low-noise forced-PWM mode disables the zero-crossing comparator, which controls the low-side switch on-time. This forces the low-side gate-drive waveform to constantly be the complement of the high-side gate-drive waveform, so the inductor current reverses at light loads while DH_{-} maintains a duty factor of V_{OUT} / V_{IN} . The benefit of forced-PWM mode is to keep the switching frequency fairly constant. However, forced-PWM operation comes at a cost: the no-load 5V supply current remains between 15mA and 50mA, depending on the external MOSFETs and switching frequency.

Forced-PWM mode is most useful for avoiding audio-frequency noise and improving load-transient response. Since forced-PWM operation disables the zero-crossing comparator, the inductor current reverses under light loads.

Light-Load Operation Control (SKIP)

The MAX1533/MAX1537 include a light-load operating-mode control input (SKIP) used to independently enable or disable the zero-crossing comparator for both controllers. When the zero-crossing comparator is enabled, the controller forces DL_{-} low when the current-sense inputs detect zero inductor current. This keeps the inductor from discharging the output capacitors and forces the controller to skip pulses under light-load conditions to avoid overcharging the output. When the zero-crossing comparator is disabled, the controller is forced to maintain PWM operation under light-load conditions (forced-PWM).

Table 4. FSEL Configuration Table

FSEL	SWITCHING FREQUENCY
VCC	500kHz
REF	300kHz
GND	200kHz

Idle-Mode Current-Sense Threshold

The on-time of the step-down controller terminates when the output voltage exceeds the feedback threshold and when the current-sense voltage exceeds the idle-mode current-sense threshold. Under light-load conditions, the on-time duration depends solely on the idle-mode current-sense threshold, which is approximately 20% of the full-load current-limit threshold set by $ILIM_{-}$. This forces the controller to source a minimum amount of power with each cycle. To avoid overcharging the output, another on-time cannot begin until the output voltage drops below the feedback threshold. Since the zero-crossing comparator prevents the switching regulator from sinking current, the controller must skip pulses. Therefore, the controller regulates the valley of the output ripple under light-load conditions.

Automatic Pulse-Skipping Crossover

In skip mode, an inherent automatic switchover to PFM takes place at light loads (Figure 4). This switchover is affected by a comparator that truncates the low-side switch on-time at the inductor current's zero crossing. The zero-crossing comparator senses the inductor current across the low-side MOSFET ($PGND$ to LX_{-}). Once $V_{PGND} - V_{LX_{-}}$ drops below the 3mV zero-crossing current-sense threshold, the comparator forces DL_{-} low (Figure 3). This mechanism causes the threshold between pulse-skipping PFM and nonskipping PWM operation to coincide with the boundary between continuous and discontinuous inductor-current operation (also known as the "critical conduction" point). The load-current level at which PFM/PWM crossover occurs, $I_{LOAD(SKIP)}$, is given by:

$$I_{LOAD(SKIP)} = \frac{V_{OUT} (V_{IN} - V_{OUT})}{2 \times V_{IN} \times f_{SW} \times L}$$

The switching waveforms may appear noisy and asynchronous when light loading causes pulse-skipping operation, but this is a normal operating condition that results in high light-load efficiency. Trade-offs in PFM noise vs. light-load efficiency are made by varying the inductor value. Generally, low inductor values produce a broader efficiency vs. load curve, while higher values result in higher full-load efficiency (assuming that the coil resistance remains fixed) and less output voltage ripple. Penalties for using higher inductor values include larger physical size and degraded load-transient response (especially at low input-voltage levels).

High-Efficiency, 5x Output, Main Power-Supply Controllers for Notebook Computers

MAX1533/MAX1537

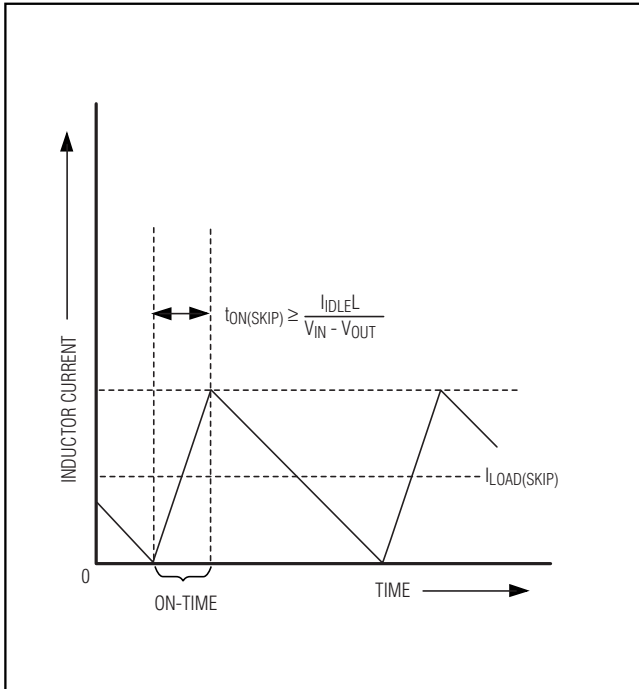

Figure 4. Pulse-Skipping/Discontinuous Crossover Point

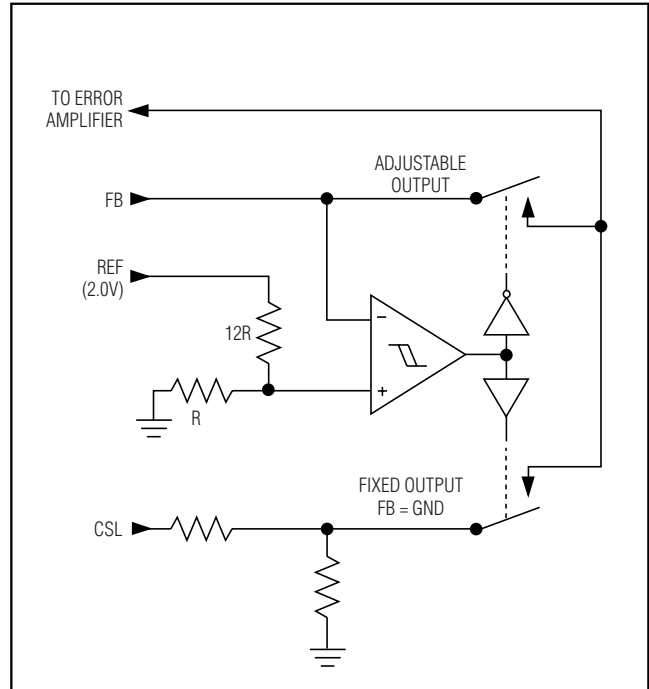

Figure 5. Dual-Mode Feedback Decoder

Output Voltage

DC output accuracy specifications in the *Electrical Characteristics* table refer to the error-comparator's threshold. When the inductor continuously conducts, the MAX1533/MAX1537 regulate the peak of the output ripple, so the actual DC output voltage is lower than the slope-compensated trip level by 50% of the output ripple voltage. For PWM operation (continuous conduction), the output voltage is accurately defined by the following equation:

$$V_{OUT(PWM)} = V_{NOM} \left(1 - \frac{A_{SLOPE} V_{NOM}}{V_{IN}} \right) - \left(\frac{V_{RIPPLE}}{2} \right)$$

where V_{NOM} is the nominal output voltage, A_{SLOPE} equals 1%, and V_{RIPPLE} is the output ripple voltage ($V_{RIPPLE} = ESR \times \Delta I_{INDUCTOR}$ as described in the *Output Capacitor Selection* section).

In discontinuous conduction ($I_{OUT} < I_{LOAD(SKIP)}$), the MAX1533/MAX1537 regulate the valley of the output ripple, so the output voltage has a DC regulation level higher than the error-comparator threshold. For PFM operation (discontinuous conduction), the output voltage is approximately defined by the following equation:

$$V_{OUT(PFM)} = V_{NOM} + \frac{1}{2} \left(\frac{f_{SW}}{f_{OSC}} \right) I_{IDLE} \times ESR$$

where V_{NOM} is the nominal output voltage, f_{OSC} is the maximum switching frequency set by the internal oscillator, f_{SW} is the actual switching frequency, and I_{IDLE} is the idle-mode inductor current when pulse skipping.

Adjustable/Fixed Output Voltages (Dual-Mode Feedback)

Connect FB3 and FB5 to GND to enable the fixed SMPS output voltages (3.3V and 5V, respectively), set by a preset, internal resistive voltage-divider connected between CSL_{-} and analog ground. Connect a resistive voltage-divider at FB_{-} between CSL_{-} and GND to adjust the respective output voltage between 1V and 5.5V (Figure 5). Choose R2 (resistance from FB to GND) to be about 10k Ω and solve for R1 (resistance from OUT to FB) using the equation:

$$R1 = R2 \left(\frac{V_{OUT_{-}}}{V_{FB_{-}}} - 1 \right)$$

where $V_{FB_{-}} = 1V$ nominal.

High-Efficiency, 5x Output, Main Power-Supply Controllers for Notebook Computers

When adjusting both output voltages, set the 3.3V SMPS lower than the 5V SMPS. LDO5 connects to the 5V output (CSL5) through an internal switch only when CSL5 is above the LDO5 bootstrap threshold (4.56V). Similarly, LDO3 connects to the 3.3V output (CSL3) through an internal switch only when CSL3 is above the LDO3 bootstrap threshold (2.91V). Bootstrapping works most effectively when the fixed output voltages are used. Once LDO_ is bootstrapped from CSL_, the internal linear regulator turns off. This reduces internal power dissipation and improves efficiency at higher input voltage.

Current-Limit Protection (ILIM_)

The current-limit circuit uses differential current-sense inputs (CSH_ and CSL_) to limit the peak inductor current. If the magnitude of the current-sense signal exceeds the current-limit threshold, the PWM controller turns off the high-side MOSFET (Figure 3). At the next rising edge of the internal oscillator, the PWM controller does not initiate a new cycle unless the current-sense signal drops below the current-limit threshold. The actual maximum load current is less than the peak current-limit threshold by an amount equal to half of the inductor ripple current. Therefore, the maximum load capability is a function of the current-sense resistance, inductor value, switching frequency, and duty cycle (V_{OUT} / V_{IN}).

In forced-PWM mode, the MAX1533/MAX1537 also implement a negative current limit to prevent excessive reverse inductor currents when V_{OUT} is sinking current. The negative current-limit threshold is set to approximately 120% of the positive current limit and tracks the positive current limit when ILIM_ is adjusted.

Connect ILIM_ to V_{CC} for the 75mV default threshold, or adjust the current-limit threshold with an external resistor-divider at ILIM_. Use a 2 μ A to 20 μ A divider current for accuracy and noise immunity. The current-limit threshold adjustment range is from 50mV to 200mV. In the adjustable mode, the current-limit threshold voltage equals precisely 1/10th the voltage seen at ILIM_. The logic threshold for switchover to the 75mV default value is approximately $V_{CC} - 1V$.

Carefully observe the PC board layout guidelines to ensure that noise and DC errors do not corrupt the differential current-sense signals seen by CSH_ and CSL_. Place the IC close to the sense resistor with short, direct traces, making a Kelvin-sense connection to the current-sense resistor.

MOSFET Gate Drivers (DH_, DL_)

The DH_ and DL_ drivers are optimized for driving moderate-sized high-side and larger low-side power MOSFETs. This is consistent with the low duty factor seen in notebook applications, where a large $V_{IN} - V_{OUT}$ differential exists. The high-side gate drivers (DH_) source and sink 2A, and the low-side gate drivers (DL_) source 1.7A and sink 3.3A. This ensures robust gate drive for high-current applications. The DH_ floating high-side MOSFET drivers are powered by diode-capacitor charge pumps at BST_ (Figure 6) while the DL_ synchronous-rectifier drivers are powered directly by the fixed 5V linear regulator (LDO5).

Adaptive dead-time circuits monitor the DL_ and DH_ drivers and prevent either FET from turning on until the other is fully off. The adaptive driver dead time allows operation without shoot-through with a wide range of MOSFETs, minimizing delays and maintaining efficiency. There must be a low-resistance, low-inductance path from the DL_ and DH_ drivers to the MOSFET gates for the adaptive dead-time circuits to work properly; otherwise, the sense circuitry in the MAX1533/MAX1537 interprets the MOSFET gates as "off" while charge actually remains. Use very short, wide traces (50 to 100 mils wide if the MOSFET is 1 inch from the driver).

The internal pulldown transistor that drives DL_ low is robust, with a 0.6 Ω (typ) on-resistance. This helps prevent DL_ from being pulled up due to capacitive coupling from the drain to the gate of the low-side MOSFETs when the inductor node (LX_) quickly switches from ground to V_{IN} . Applications with high input voltages and long inductive driver traces may require additional gate-to-source capacitance to ensure fast-rising LX_ edges do not pull up the low-side MOSFETs' gate, causing shoot-through currents. The capacitive coupling between LX_ and DL_ created by the MOSFET's gate-to-drain capacitance (C_{RSS}), gate-to-source capacitance ($C_{ISS} - C_{RSS}$), and additional board parasitics should not exceed the following minimum threshold:

$$V_{GS(TH)} > V_{IN} \left(\frac{C_{RSS}}{C_{ISS}} \right)$$

Lot-to-lot variation of the threshold voltage may cause problems in marginal designs. Alternatively, adding a resistor less than 10 Ω in series with BST_ may remedy the problem by increasing the turn-on time of the high-side MOSFET without degrading the turn-off time (Figure 6).

High-Efficiency, 5x Output, Main Power-Supply Controllers for Notebook Computers

MAX1533/MAX1537

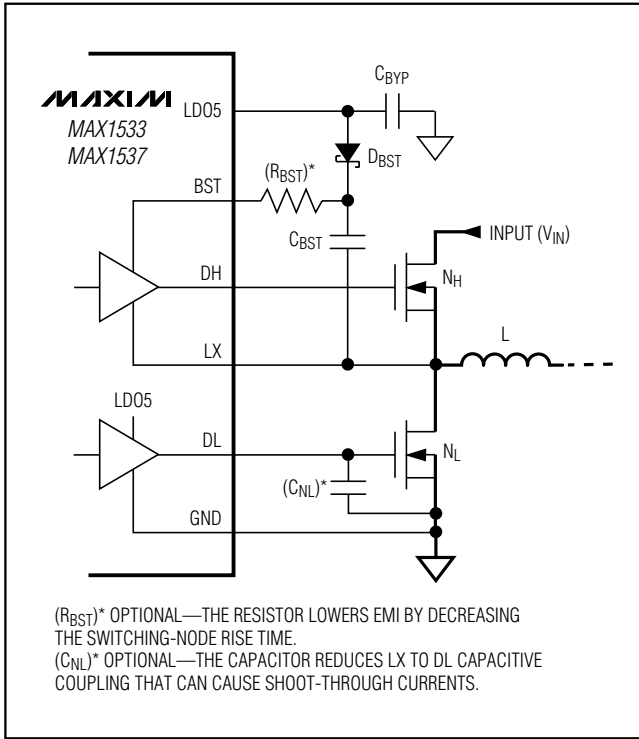

Figure 6. Optional Gate-Driver Circuitry

Power-Good Output (PGOOD)

PGOOD is the open-drain output of a comparator that continuously monitors both SMPS output voltages for undervoltage conditions. PGOOD is actively held low in shutdown (SHDN or ON3 or ON5 = GND), soft-start, and soft-shutdown. Once the digital soft-start terminates, PGOOD becomes high impedance as long as both outputs are above 90% of the nominal regulation voltage set by FB_. PGOOD goes low once either SMPS output drops 10% below its nominal regulation point, an output overvoltage fault occurs, or either SMPS controller is shut down. For a logic-level PGOOD output voltage, connect an external pullup resistor between PGOOD and VCC. A 100kΩ pullup resistor works well in most applications.

PGOOD is independent of the fault protection states OVP and UVP.

Fault Protection

Output Overvoltage Protection (OVP)

If the output voltage of either SMPS rises above 111% of its nominal regulation voltage and the OVP protection is enabled (OVP = GND), the controller sets the fault latch, pulls PGOOD low, shuts down both SMPS controllers, and immediately pulls DH_ low and forces DL_

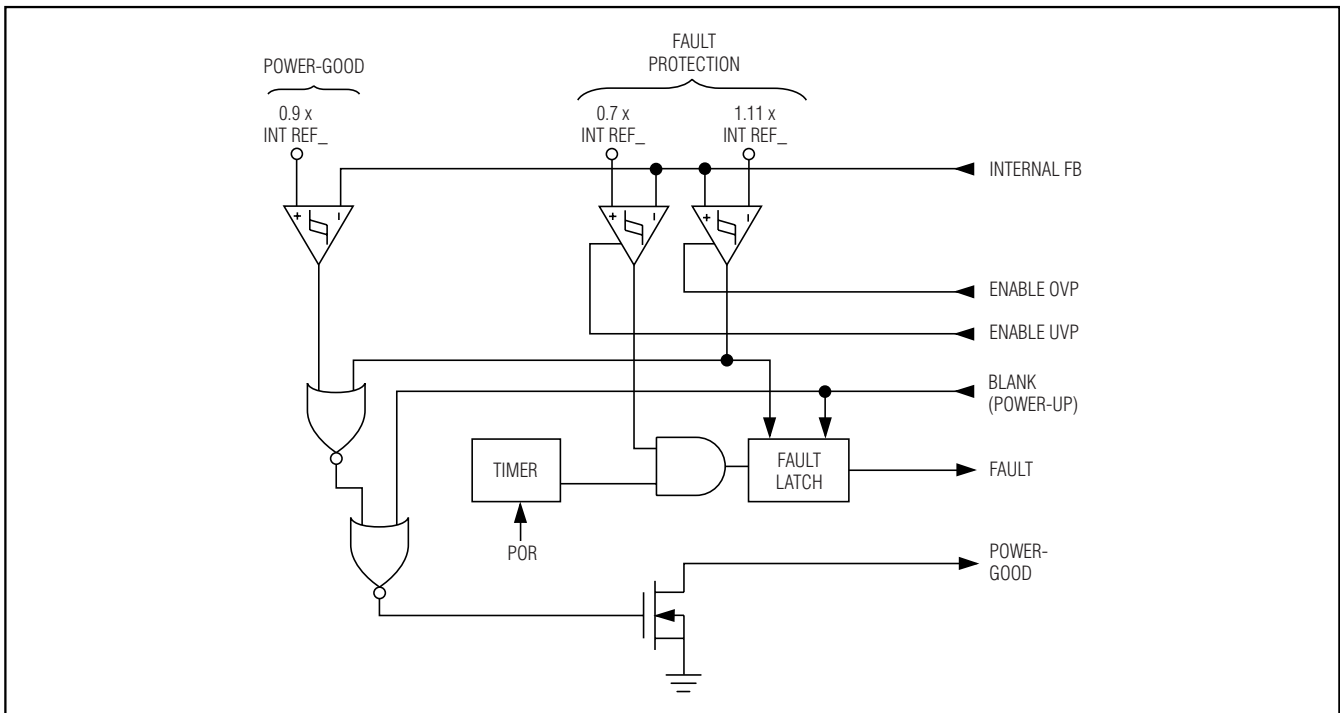

Figure 7. Power-Good and Fault Protection