



Chipsmall Limited consists of a professional team with an average of over 10 year of expertise in the distribution of electronic components. Based in Hongkong, we have already established firm and mutual-benefit business relationships with customers from,Europe,America and south Asia,supplying obsolete and hard-to-find components to meet their specific needs.

With the principle of “Quality Parts,Customers Priority,Honest Operation,and Considerate Service”,our business mainly focus on the distribution of electronic components. Line cards we deal with include Microchip,ALPS,ROHM,Xilinx,Pulse,ON,Everlight and Freescale. Main products comprise IC,Modules,Potentiometer,IC Socket,Relay,Connector.Our parts cover such applications as commercial,industrial, and automotives areas.

We are looking forward to setting up business relationship with you and hope to provide you with the best service and solution. Let us make a better world for our industry!



Contact us

Tel: +86-755-8981 8866 Fax: +86-755-8427 6832

Email & Skype: info@chipsmall.com Web: www.chipsmall.com

Address: A1208, Overseas Decoration Building, #122 Zhenhua RD., Futian, Shenzhen, China



MAX16000–MAX16007

Low-Voltage, Quad-/Hex-/Octal-Voltage μ P Supervisors

General Description

The MAX16000–MAX16007 are low-voltage, quad-/hex-/octal-voltage μ P supervisors in small TQFN and TSSOP packages. These devices provide supervisory functions for complex multivoltage systems. The MAX16000/MAX16001/MAX16002 monitor four voltages, the MAX16003/MAX16004/MAX16005 monitor six voltages, and the MAX16006/MAX16007 monitor eight voltages.

The MAX16000/MAX16001/MAX16003/MAX16004/MAX16006 offer independent outputs for each monitored voltage. The MAX16001/MAX16002/MAX16004–MAX16007 offer a reset output that asserts whenever any of the monitored voltages fall below their respective thresholds or the manual reset input is asserted. The reset output remains asserted for the reset timeout after all voltages are above their respective thresholds and the manual reset input is deasserted. The minimum reset timeout is internally set to 140ms or can be adjusted with an external capacitor.

All open-drain outputs have internal 30 μ A pullups that eliminate the need for external pullup resistors. However, each output can be driven with an external voltage up to 5.5V. Other features offered include a manual reset input, a tolerance pin for selecting 5% or 10% input thresholds, and a margin enable function for deasserting the outputs during margin testing.

The MAX16001/MAX16002/MAX16004–MAX16007 offer a watchdog timer that asserts $\overline{\text{RESET}}$ or an independent watchdog output (MAX16005) when the watchdog timeout period (1.6s typ) is exceeded. The watchdog timer can be disabled by leaving the input open.

These devices are offered in 12-, 16-, 20-, and 24-pin TQFN and 16-pin TSSOP packages. These are fully specified from -40°C to +125°C.

Applications

Storage Equipment
Servers
Networking/Telecommunication Equipment
Multivoltage ASICs

Selector Guide appears at end of data sheet.

Features

- ◆ Fixed Thresholds for 5V, 3.3V, 3V, 2.5V, 1.8V, 1.5V, 1.2V, and 0.9V Systems
- ◆ Adjustable Thresholds Monitor Voltages Down to 0.4V
- ◆ Open-Drain Outputs with Internal Pullups Reduce the Number of External Components
- ◆ Fixed 140ms (min) or Capacitor-Adjustable Reset Timeout
- ◆ Manual Reset, Margin Enable, and Tolerance Select Inputs
- ◆ Watchdog Timer
 - 1.6s (typ) Timeout Period
 - 54s Startup Delay After Reset (Except MAX16005)
- ◆ Independent Watchdog Output (MAX16005)
- ◆ $\overline{\text{RESET}}$ Output Indicates All Voltages Present
- ◆ Independent Voltage Monitors
- ◆ Guaranteed Correct Logic State Down to $V_{CC} = 1V$
- ◆ Small (4mm x 4mm) TQFN Package
- ◆ TSSOP (5mm x 4.4mm) Package (MAX16005)

Ordering Information

PART	TEMP RANGE	PIN-PACKAGE
MAX16000_TC+	-40°C to +125°C	12 TQFN-EP*

Note: The “_” is a placeholder for the input voltage threshold. See Table 1.

+ Denotes a lead(Pb)-free/RoHS-compliant package.

For tape-and-reel, add a “T” after the “+.” Tape-and-reel are offered in 2.5k increments.

*EP = Exposed pad.

Ordering Information continued at end of data sheet.

Typical Operating Circuit

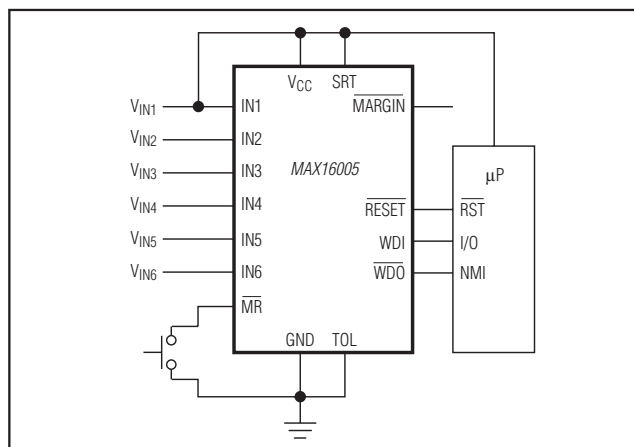

For pricing, delivery, and ordering information, please contact Maxim Direct at 1-888-629-4642, or visit Maxim’s website at www.maximintegrated.com.

MAX16000–MAX16007

Low-Voltage, Quad-/Hex-/Octal-Voltage μ P Supervisors

ABSOLUTE MAXIMUM RATINGS

V_{CC} , OUT_{-} , IN_{-} , \overline{RESET} , \overline{WDO} to GND -0.3V to +6V
 TOL , $MARGIN$, \overline{MR} , SRT , \overline{WDI} , to GND -0.3V to $V_{CC} + 0.3$
 Input/Output Current (\overline{RESET} , $MARGIN$,
 SRT , \overline{MR} , TOL , OUT_{-} , \overline{WDO} , \overline{WDI}) ± 20 mA
 Continuous Power Dissipation ($T_A = +70^{\circ}C$)
 12-Pin TQFN (derate 16.9mW/ $^{\circ}C$ above +70 $^{\circ}C$) 1349mW
 16-Pin TQFN (derate 16.9mW/ $^{\circ}C$ above +70 $^{\circ}C$) 1349mW
 20-Pin TQFN (derate 16.9mW/ $^{\circ}C$ above +70 $^{\circ}C$) 1355mW
 24-Pin TQFN (derate 16.9mW/ $^{\circ}C$ above +70 $^{\circ}C$) 1666mW
 16-Pin TSSOP (derate 9.4mW/ $^{\circ}C$ above +70 $^{\circ}C$) 754mW

Operating Temperature Range -40 $^{\circ}C$ to +125 $^{\circ}C$
 Junction Temperature +150 $^{\circ}C$
 Storage Temperature Range -65 $^{\circ}C$ to +150 $^{\circ}C$
 Lead Temperature (soldering, 10s) +300 $^{\circ}C$
 Soldering Temperature (reflow) +260 $^{\circ}C$

Stresses beyond those listed under "Absolute Maximum Ratings" may cause permanent damage to the device. These are stress ratings only, and functional operation of the device at these or any other conditions beyond those indicated in the operational sections of the specifications is not implied. Exposure to absolute maximum rating conditions for extended periods may affect device reliability.

ELECTRICAL CHARACTERISTICS

($V_{CC} = 2.0V$ to $5.5V$, $T_A = -40^{\circ}C$ to +125 $^{\circ}C$, unless otherwise specified. Typical values are at $V_{CC} = 3.3V$, $T_A = +25^{\circ}C$.) (Note 1)

PARAMETER	SYMBOL	CONDITIONS	MIN	TYP	MAX	UNITS
Operating Voltage Range	V_{CC}	(Note 2)	1.0		5.5	V
Supply Current	I_{CC}	$V_{CC} = 3.3V$, OUT_{-} , \overline{RESET} not asserted (Note 3)		45	65	μA
		$V_{CC} = 5V$, OUT_{-} , \overline{RESET} not asserted		50	70	
UVLO (Undervoltage Lockout)	V_{UVLO}	V_{CC} rising	1.62	1.8	1.98	V
IN_{-} (See Table 1)						
Threshold Voltages (IN_{-} Falling)	V_{TH}	5V threshold, $TOL = GND$	4.50	4.625	4.75	V
		5V threshold, $TOL = V_{CC}$	4.25	4.375	4.50	
		3.3V threshold, $TOL = GND$	2.970	3.053	3.135	
		3.3V threshold, $TOL = V_{CC}$	2.805	2.888	2.970	
		3.0V threshold, $TOL = GND$	2.70	2.775	2.85	
		3.0V threshold, $TOL = V_{CC}$	2.55	2.625	2.70	
		2.5V threshold, $TOL = GND$	2.250	2.313	2.375	
		2.5V threshold, $TOL = V_{CC}$	2.125	2.188	2.250	
		1.8V threshold, $TOL = GND$	1.62	1.665	1.71	
		1.8V threshold, $TOL = V_{CC}$	1.53	1.575	1.62	
		1.5V threshold, $TOL = GND$	1.350	1.388	1.425	
		1.5V threshold, $TOL = V_{CC}$	1.275	1.313	1.350	
		1.2V threshold, $TOL = GND$	1.08	1.11	1.14	
		1.2V threshold, $TOL = V_{CC}$	1.02	1.05	1.08	
		0.9V threshold, $TOL = GND$	0.810	0.833	0.855	
0.9V threshold, $TOL = V_{CC}$	0.765	0.788	0.810			

MAX16000–MAX16007

Low-Voltage, Quad-/Hex-/Octal-Voltage μP Supervisors

ELECTRICAL CHARACTERISTICS (continued)

(V_{CC} = 2.0V to 5.5V, T_A = -40°C to +125°C, unless otherwise specified. Typical values are at V_{CC} = 3.3V, T_A = +25°C.) (Note 1)

PARAMETER	SYMBOL	CONDITIONS	MIN	TYP	MAX	UNITS
Adjustable Threshold (IN_ Falling)	V _{TH}	TOL = GND	0.388	0.394	0.400	V
		TOL = V _{CC}	0.366	0.372	0.378	
IN_ Hysteresis	V _{THLHYS}	IN_ rising		0.5		% V _{TH}
IN_ Input Current		Fixed thresholds		3	16	μA
		Adjustable thresholds	-100		+100	nA
RESET						
Reset Timeout	t _{RP}	SRT = V _{CC}	140	200	280	ms
		CSRT = 1500pF (Note 4)	2.43	3.09	3.92	
		CSRT = 100pF		0.206		
		CSRT = open		50		
SRT Ramp Current	I _{SRT}	V _{SRT} = 0V	460	600	740	nA
SRT Threshold			1.173	1.235	1.293	V
SRT Hysteresis				100		mV
IN_ to Reset Delay	t _{RD}	IN_ falling		20		μs
RESET Output-Voltage Low	V _{OL}	V _{CC} = 3.3V, I _{SINK} = 10mA, RESET asserted			0.30	V
		V _{CC} = 2.5V, I _{SINK} = 6mA, RESET asserted			0.30	
		V _{CC} = 1.2V, I _{SINK} = 50μA, RESET asserted			0.30	
RESET Output-Voltage High	V _{OH}	V _{CC} ≥ 2.0V, I _{SOURCE} = 6μA, RESET deasserted	0.8 x V _{CC}			V
MR Input-Voltage Low	V _{IL}				0.3 x V _{CC}	V
MR Input-Voltage High	V _{IH}		0.7 x V _{CC}			V
MR Minimum Pulse Width			1			μs
MR Glitch Rejection				100		ns
MR to Reset Delay				200		ns
MR Pullup Resistance		Pulled up to V _{CC}	12	20	28	kΩ
OUTPUTS (OUT_)						
OUT_ Output-Voltage Low	V _{OL}	V _{CC} = 3.3V, I _{SINK} = 2mA			0.30	V
		V _{CC} = 2.5V, I _{SINK} = 1.2mA			0.30	
OUT_ Output-Voltage High	V _{OH}	V _{CC} ≥ 2.0V, I _{SOURCE} = 6μA	0.8 x V _{CC}			V
IN_ to OUT_ Propagation Delay	t _D	(V _{TH} + 100mV) to (V _{TH} - 100mV)		20		μs

MAX16000–MAX16007

Low-Voltage, Quad-/Hex-/Octal-Voltage μ P Supervisors

ELECTRICAL CHARACTERISTICS (continued)

($V_{CC} = 2.0V$ to $5.5V$, $T_A = -40^{\circ}C$ to $+125^{\circ}C$, unless otherwise specified. Typical values are at $V_{CC} = 3.3V$, $T_A = +25^{\circ}C$). (Note 1)

PARAMETER	SYMBOL	CONDITIONS	MIN	TYP	MAX	UNITS
REFERENCE OUTPUT (MAX16005 Only)						
Reference Short-Circuit Current		Shorted to GND		0.8		mA
Reference Output Accuracy	V_{REF}	No load	1.200	1.235	1.270	V
Line Regulation				0.005		% / V
Reference Load Regulation		Sourcing, $0 \leq I_{REF} \leq 40\mu A$		10		Ω
WATCHDOG TIMER (MAX16001/MAX16002/MAX16004–MAX16007)						
WDI Input-Voltage Low	V_{IL}				$0.3 \times V_{CC}$	V
WDI Input-Voltage High	V_{IH}		$0.7 \times V_{CC}$			V
WDI Pulse Width		(Note 5)	50			ns
Watchdog Timeout Period	t_{WDI}		1.12	1.6	2.40	s
Watchdog Startup Period		MAX16001/2/4/6/7	35	54	72	s
Watchdog Input Current		$V_{WDI} = 0$ to V_{CC} (Note 5)	-1		+1	μA
\overline{WDO} Output-Voltage Low (MAX16005 Only)	V_{OL}	$V_{CC} = 3.3V$, $I_{SINK} = 2mA$ $V_{CC} = 2.5V$, $I_{SINK} = 1.2mA$			0.30	V
\overline{WDO} Output-Voltage High (MAX16005 Only)	V_{OH}	$V_{CC} \geq 2.0V$, $I_{SOURCE} = 6\mu A$, \overline{WDO} deasserted	$0.8 \times V_{CC}$			V
DIGITAL LOGIC						
TOL Input-Voltage Low	V_{IL}				$0.3 \times V_{CC}$	V
TOL Input-Voltage High	V_{IH}		$0.7 \times V_{CC}$			V
TOL Input Current		$TOL = V_{CC}$			100	nA
\overline{MARGIN} Input-Voltage Low	V_{IL}				$0.3 \times V_{CC}$	V
\overline{MARGIN} Input-Voltage High	V_{IH}		$0.7 \times V_{CC}$			V
\overline{MARGIN} Pullup Resistance		Pulled up to V_{CC}	12	20	28	$k\Omega$
\overline{MARGIN} Delay Time	t_{MD}	Rising or falling (Note 6)		50		μs

Note 1: Devices are tested at $T_A = +25^{\circ}C$ and guaranteed by design for $T_A = T_{MIN}$ to T_{MAX} .

Note 2: The outputs are guaranteed to be in the correct logic state down to $V_{CC} = 1V$.

Note 3: Measured with WDI, \overline{MARGIN} , and \overline{MR} unconnected.

Note 4: The minimum and maximum specifications for this parameter are guaranteed by using the worst case of the SRT ramp current and SRT threshold specifications.

Note 5: Guaranteed by design and not production tested.

Note 6: Amount of time required for logic to lock/unlock outputs from margin testing.

MAX16000-MAX16007

Low-Voltage, Quad-/Hex-/Octal-Voltage μ P Supervisors

Typical Operating Characteristics

($V_{CC} = 3.3V$, $T_A = +25^\circ C$, unless otherwise noted.)

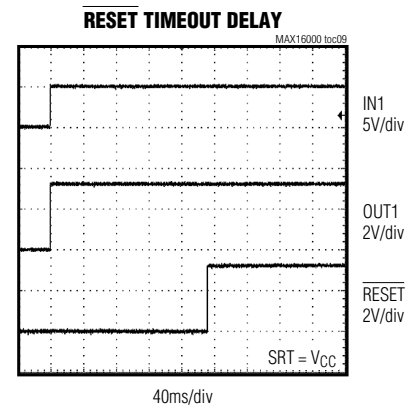
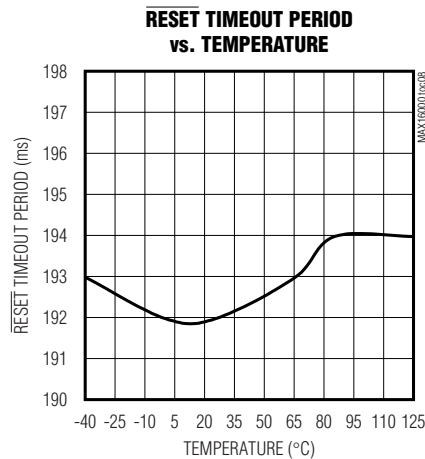
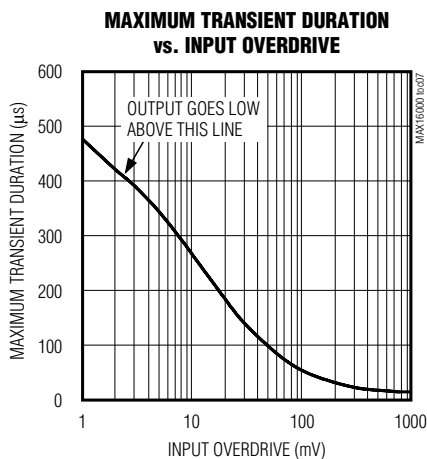
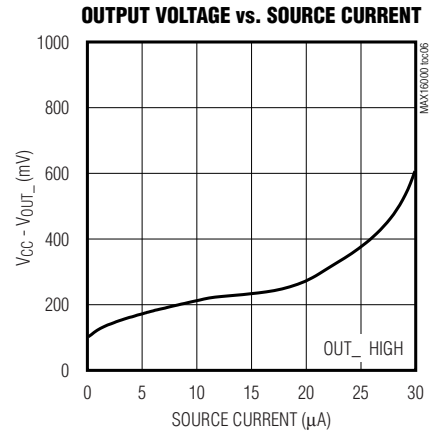
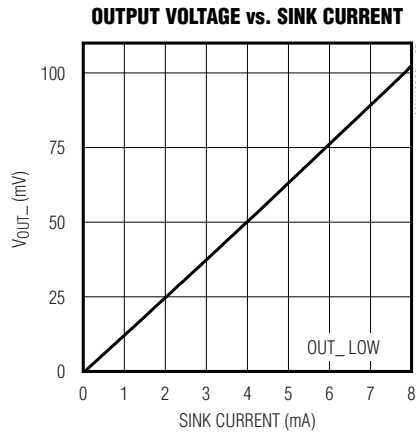
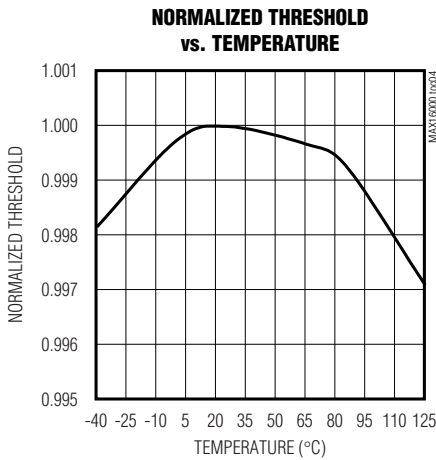
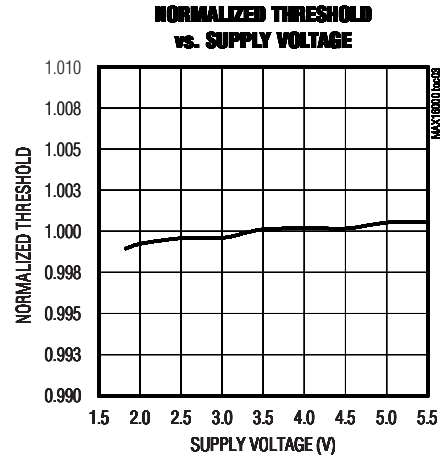
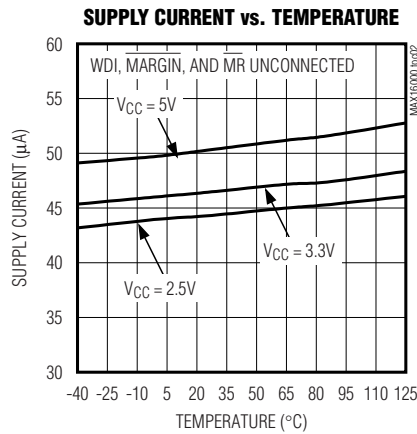
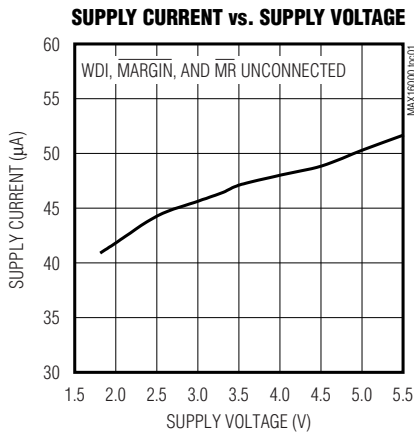

MAX16000-MAX16007

Low-Voltage, Quad-/Hex-/Octal-Voltage μ P Supervisors

Typical Operating Characteristics (continued)

($V_{CC} = 3.3V$, $T_A = +25^\circ C$, unless otherwise noted.)

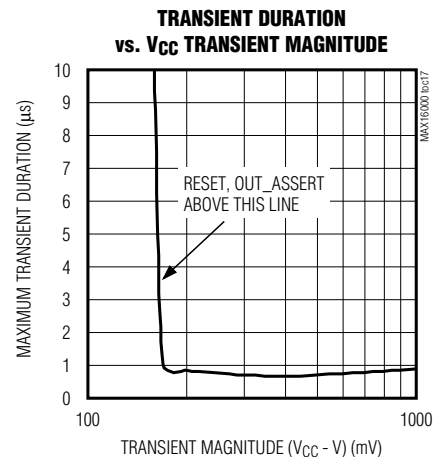
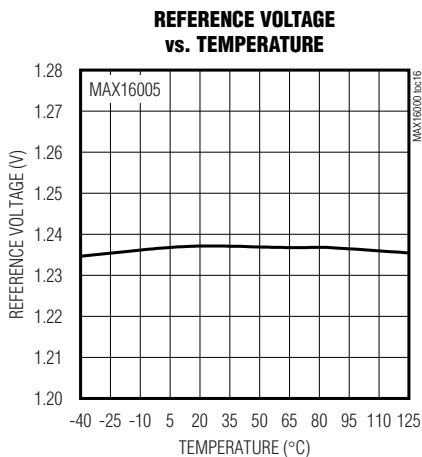
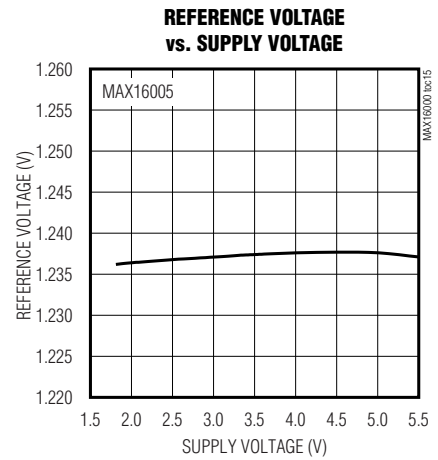
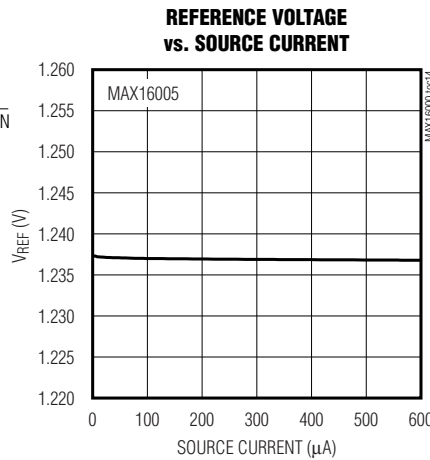
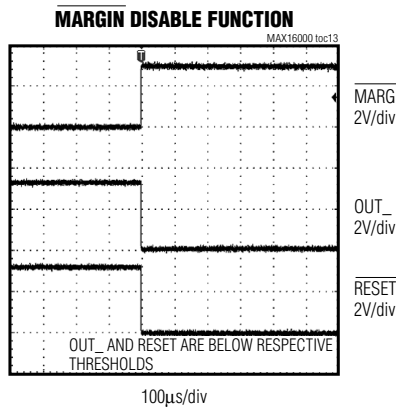
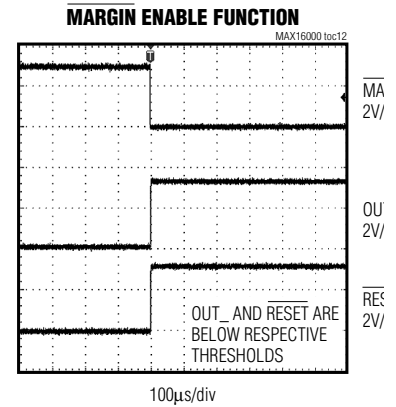
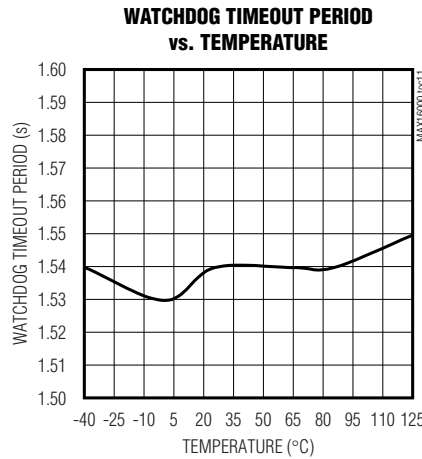
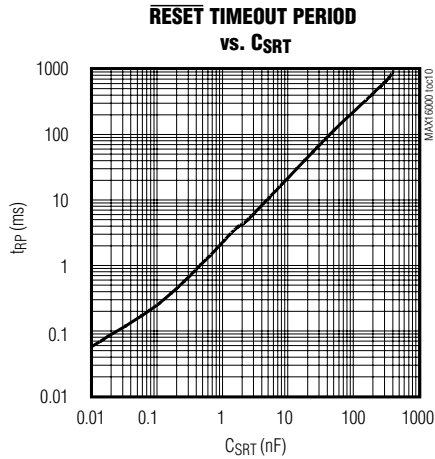

MAX16000–MAX16007

Low-Voltage, Quad-/Hex-/Octal-Voltage μP Supervisors

Pin Description (MAX16000/MAX16001/MAX16002)

PIN			NAME	FUNCTION
MAX16000	MAX16001	MAX16002		
1	1	1	IN3	Monitored Input Voltage 3. See Table 1 for the input voltage threshold.
2	2	2	IN4	Monitored Input Voltage 4. See Table 1 for the input voltage threshold.
3	4	4	GND	Ground
4	5	5	V _{CC}	Unmonitored Power-Supply Input
5	6	—	OUT3	Output 3. When the voltage at IN3 falls below its threshold, OUT3 goes low and stays low until the voltage at IN3 exceeds its threshold. The open-drain output has a 30μA internal pullup to V _{CC} .
6	7	—	OUT4	Output 4. When the voltage at IN4 falls below its threshold, OUT4 goes low and stays low until the voltage at IN4 exceeds its threshold. The open-drain output has a 30μA internal pullup to V _{CC} .
7	10	8	$\overline{\text{MARGIN}}$	Active-Low Manual Deassert Input. Pull $\overline{\text{MARGIN}}$ low to deassert all outputs (go into high state), regardless of the voltage at any monitored input.
8	11	—	OUT2	Output 2. When the voltage at IN2 falls below its threshold, OUT2 goes low and stays low until the voltage at IN2 exceeds its threshold. The open-drain output has a 30μA internal pullup to V _{CC} .
9	12	—	OUT1	Output 1. When the voltage at IN1 falls below its threshold, OUT1 goes low and stays low until the voltage at IN1 exceeds its threshold. The open-drain output has a 30μA internal pullup to V _{CC} .
10	14	10	IN1	Monitored Input Voltage 1. See Table 1 for the input voltage threshold.
11	15	11	IN2	Monitored Input Voltage 2. See Table 1 for the input voltage threshold.
12	16	12	TOL	Threshold Tolerance Input. Connect TOL to GND to select 5% threshold tolerance. Connect TOL to V _{CC} to select 10% threshold tolerance.
—	3	3	WDI	Watchdog Timer Input. If WDI remains low or high for longer than the watchdog timeout period, $\overline{\text{RESET}}$ is asserted. The timer clears whenever a reset is asserted or a rising or falling edge on WDI is detected. The watchdog timer enters a startup period that allows 54s for the first transition to occur before a reset. Leave WDI unconnected to disable the watchdog timer. The WDI open-state detector uses a small 400nA current. Therefore, do not connect WDI to anything that will source or sink more than 200nA. Note that the leakage current specification for most three-state drivers exceeds 200nA.
—	8	6	$\overline{\text{MR}}$	Active-Low Manual Reset Input. Pull $\overline{\text{MR}}$ low to assert $\overline{\text{RESET}}$ low. $\overline{\text{RESET}}$ remains low for the reset timeout period after $\overline{\text{MR}}$ is deasserted. $\overline{\text{MR}}$ is pulled up to V _{CC} through a 20kΩ resistor.
—	9	7	SRT	Set Reset Timeout Input. Connect a capacitor from SRT to GND to set the reset timeout period. The reset timeout period can be calculated as follows: Reset Timeout (s) = $2.06 \times 10^6 (\Omega) \times C_{\text{SRT}} (\text{F})$. For the internal timeout period of 140ms (min), connect SRT to V _{CC} .
—	13	9	$\overline{\text{RESET}}$	Active-Low Reset Output. $\overline{\text{RESET}}$ asserts low when any of the monitored voltages falls below its respective threshold or $\overline{\text{MR}}$ is asserted. $\overline{\text{RESET}}$ remains asserted for the reset timeout period after all monitored voltages exceed their respective thresholds and $\overline{\text{MR}}$ is deasserted. This open-drain output has a 30μA internal pullup.
—	—	—	EP	Exposed Pad. EP is internally connected to GND. Connect EP to the ground plane to provide a low thermal resistance path from the IC junction to the PCB. Do not use as the electrical connection to GND.

MAX16000–MAX16007

Low-Voltage, Quad-/Hex-/Octal-Voltage μ P Supervisors

Pin Description (MAX16003/MAX16004/MAX16005)

PIN				NAME	FUNCTION
MAX16003	MAX16004	MAX16005 TSSOP	MAX16005 TQFN		
1	1	3	1	IN4	Monitored Input Voltage 4. See Table 1 for the input voltage threshold.
2	2	4	2	IN5	Monitored Input Voltage 5. See Table 1 for the input voltage threshold.
3	3	5	3	IN6	Monitored Input Voltage 6. See Table 1 for the input voltage threshold.
4	5	7	5	GND	Ground
5	6	8	6	V _{CC}	Unmonitored Power-Supply Input
6	7	—	—	OUT4	Output 4. When the voltage at IN4 falls below its threshold, OUT4 goes low and stays low until the voltage at IN4 exceeds its threshold. The open-drain output has a 30 μ A internal pullup to V _{CC} .
7	8	—	—	OUT5	Output 5. When the voltage at IN5 falls below its threshold, OUT5 goes low and stays low until the voltage at IN5 exceeds its threshold. The open-drain output has a 30 μ A internal pullup to V _{CC} .
8	9	—	—	OUT6	Output 6. When the voltage at IN6 falls below its threshold, OUT6 goes low and stays low until the voltage at IN6 exceeds its threshold. The open-drain output has a 30 μ A internal pullup to V _{CC} .
9	12	13	11	$\overline{\text{MARGIN}}$	Manual Deassert Input. Pull $\overline{\text{MARGIN}}$ low to deassert all outputs (go into high state), regardless of the voltage at any monitored input.
10	13	—	—	OUT3	Output 3. When the voltage at IN3 falls below its threshold, OUT3 goes low and stays low until the voltage at IN3 exceeds its threshold. The open-drain output has a 30 μ A internal pullup to V _{CC} .
11	14	—	—	OUT2	Output 2. When the voltage at IN2 falls below its threshold, OUT2 goes low and stays low until the voltage at IN2 exceeds its threshold. The open-drain output has a 30 μ A internal pullup to V _{CC} .
12	15	—	—	OUT1	Output 1. When the voltage at IN1 falls below its threshold, OUT1 goes low and stays low until the voltage at IN1 exceeds its threshold. The open-drain output has a 30 μ A internal pullup to V _{CC} .
13	17	15	13	IN1	Monitored Input Voltage 1. See Table 1 for the input voltage threshold.
14	18	16	14	IN2	Monitored Input Voltage 2. See Table 1 for the input voltage threshold.
15	19	1	15	IN3	Monitored Input Voltage 3. See Table 1 for the input voltage threshold.

MAX16000–MAX16007

Low-Voltage, Quad-/Hex-/Octal-Voltage μP Supervisors

Pin Description (MAX16003/MAX16004/MAX16005) (continued)

PIN				NAME	FUNCTION
MAX16003	MAX16004	MAX16005 TSSOP	MAX16005 TQFN		
16	20	2	16	TOL	Threshold Tolerance Input. Connect TOL to GND to select 5% threshold tolerance. Connect TOL to V _{CC} to select 10% threshold tolerance.
—	4	6	4	WDI	<p>Watchdog Timer Input.</p> <p>MAX16004: If WDI remains low or high for longer than the watchdog timeout period, $\overline{\text{RESET}}$ is asserted and the timer is cleared. The timer also clears whenever a reset is asserted or a rising or falling edge on WDI is detected. The watchdog timer enters a startup period that allows 54s for the first transition to occur before a reset. Leave WDI unconnected to disable the watchdog timer.</p> <p>MAX16005: If WDI remains low or high for longer than the watchdog timeout period, $\overline{\text{WDO}}$ is asserted. The timer clears whenever a rising or falling edge on WDI is detected. Leave WDI unconnected to disable the watchdog timer. The MAX16005 does not have a startup period.</p> <p>MAX16004/MAX16005: The WDI open-state detector uses a small 100nA current. Therefore, do not connect WDI to anything that will source or sink more than 50nA. Note that the leakage current specification for most three-state drivers exceeds 50nA.</p>
—	10	11	9	$\overline{\text{MR}}$	Active-Low Manual Reset Input. Pull $\overline{\text{MR}}$ low to assert $\overline{\text{RESET}}$ low. $\overline{\text{RESET}}$ remains low for the reset timeout period after $\overline{\text{MR}}$ is deasserted. $\overline{\text{MR}}$ is pulled up to V _{CC} through a 20kΩ resistor.
—	11	12	10	SRT	Set Reset Timeout Input. Connect a capacitor from SRT to GND to set the reset timeout period. The reset timeout period can be calculated as follows: Reset Timeout (s) = $2.06 \times 10^6 (\Omega) \times C_{\text{SRT}} (\text{F})$. For the internal timeout period of 140ms (min), connect SRT to V _{CC} .
—	16	14	12	$\overline{\text{RESET}}$	Active-Low Reset Output. $\overline{\text{RESET}}$ asserts low when any of the monitored voltages falls below its respective threshold or $\overline{\text{MR}}$ is asserted. $\overline{\text{RESET}}$ remains asserted for the reset timeout period after all monitored voltages exceed their respective thresholds and $\overline{\text{MR}}$ is deasserted. This open-drain output has a 30μA internal pullup.
—	—	9	7	REF	Reference Output. The reference output voltage of 1.23V can source up to 40μA.
—	—	10	8	$\overline{\text{WDO}}$	Active-Low Watchdog Output. $\overline{\text{WDO}}$ asserts and stays low whenever any of the IN_ inputs fall below their respective thresholds. $\overline{\text{WDO}}$ deasserts without a timeout delay when all the IN_ inputs rise above their thresholds. When all the IN_ inputs rise above their thresholds, $\overline{\text{WDO}}$ asserts low whenever the watchdog timer times out. $\overline{\text{WDO}}$ deasserts after a valid WDI transition or if $\overline{\text{MR}}$ is pulled low. The watchdog timer begins counting after the reset timeout period once $\overline{\text{MR}}$ goes high. Pull $\overline{\text{MARGIN}}$ low to deassert $\overline{\text{WDO}}$.
—	—	—	—	EP	Exposed Pad. EP is internally connected to GND. Connect EP to the ground plane to provide a low thermal resistance path from the IC junction to the PCB. Do not use as the electrical connection to GND.

MAX16000–MAX16007

Low-Voltage, Quad-/Hex-/Octal-Voltage μ P Supervisors

Pin Description (MAX16006/MAX16007)

PIN		NAME	FUNCTION
MAX16006	MAX16007		
1	1	IN5	Monitored Input Voltage 5. See Table 1 for the input voltage threshold.
2	2	IN6	Monitored Input Voltage 6. See Table 1 for the input voltage threshold.
3	3	IN7	Monitored Input Voltage 7. See Table 1 for the input voltage threshold.
4	4	IN8	Monitored Input Voltage 8. See Table 1 for the input voltage threshold.
5	5	WDI	Watchdog Timer Input. If WDI remains low or high for longer than the watchdog timeout period, RESET is asserted and the timer is cleared. The timer also clears whenever a reset is asserted or a rising or falling edge on WDI is detected. The watchdog timer enters a startup period that allows 54s for the first transition to occur before a reset. Leave WDI unconnected to disable the watchdog timer. The WDI open-state detector uses a small 400nA current. Therefore, do not connect WDI to anything that will source or sink more than 200nA. Note that the leakage current specification for most three-state drivers exceeds 200nA.
6	6	GND	Ground
7	7	VCC	Unmonitored Power-Supply Input
8	—	OUT5	Output 5. When the voltage at IN5 falls below its threshold, OUT5 goes low and stays low until the voltage at IN5 exceeds its threshold. The open-drain output has a 30 μ A internal pullup to VCC.
9	—	OUT6	Output 6. When the voltage at IN6 falls below its threshold, OUT6 goes low and stays low until the voltage at IN6 exceeds its threshold. The open-drain output has a 30 μ A internal pullup to VCC.
10	—	OUT7	Output 7. When the voltage at IN7 falls below its threshold, OUT7 goes low and stays low until the voltage at IN7 exceeds its threshold. The open-drain output has a 30 μ A internal pullup to VCC.
11	—	OUT8	Output 8. When the voltage at IN8 falls below its threshold, OUT8 goes low and stays low until the voltage at IN8 exceeds its threshold. The open-drain output has a 30 μ A internal pullup to VCC.
12	10	$\overline{\text{MR}}$	Active-Low Manual Reset Input. Pull $\overline{\text{MR}}$ low to assert RESET low. RESET remains low for the reset timeout period after $\overline{\text{MR}}$ is deasserted. $\overline{\text{MR}}$ is pulled up to VCC through a 20k Ω resistor.
13	11	SRT	Set Reset Timeout Input. Connect a capacitor from SRT to GND to set the reset timeout period. The reset timeout period can be calculated as follows: Reset Timeout (s) = 2.06 x 10 ⁶ (Ω) x CSRT (F). For the internal timeout period of 140ms (min), connect SRT to VCC.

MAX16000–MAX16007

Low-Voltage, Quad-/Hex-/Octal-Voltage μP Supervisors

Pin Description (MAX16006/MAX16007) (continued)

PIN		NAME	FUNCTION
MAX16006	MAX16007		
14	12	$\overline{\text{MARGIN}}$	Margin Disable Input. Pull $\overline{\text{MARGIN}}$ low to deassert all outputs (go into high state), regardless of the voltage at any monitored input.
15	—	OUT4	Output 4. When the voltage at IN4 falls below its threshold, OUT4 goes low and stays low until the voltage at IN4 exceeds its threshold. The open-drain output has a 30μA internal pullup to V _{CC} .
16	—	OUT3	Output 3. When the voltage at IN3 falls below its threshold, OUT3 goes low and stays low until the voltage at IN3 exceeds its threshold. The open-drain output has a 30μA internal pullup to V _{CC} .
17	—	OUT2	Output 2. When the voltage at IN2 falls below its threshold, OUT2 goes low and stays low until the voltage at IN2 exceeds its threshold. The open-drain output has a 30μA internal pullup to V _{CC} .
18	—	OUT1	Output 1. When the voltage at IN1 falls below its threshold, OUT1 goes low and stays low until the voltage at IN1 exceeds its threshold. The open-drain output has a 30μA internal pullup to V _{CC} .
19	15	$\overline{\text{RESET}}$	Active-Low Reset Output. $\overline{\text{RESET}}$ asserts low when any of the monitored voltages falls below its respective threshold or $\overline{\text{MR}}$ is asserted. $\overline{\text{RESET}}$ remains asserted for the reset timeout period after all monitored voltages exceed their respective thresholds and $\overline{\text{MR}}$ is deasserted. This open-drain output has a 30μA internal pullup.
20	16	IN1	Monitored Input Voltage 1. See Table 1 for the input voltage threshold.
21	17	IN2	Monitored Input Voltage 2. See Table 1 for the input voltage threshold.
22	18	IN3	Monitored Input Voltage 3. See Table 1 for the input voltage threshold.
23	19	IN4	Monitored Input Voltage 4. See Table 1 for the input voltage threshold.
24	20	TOL	Threshold Tolerance Input. Connect TOL to GND to select 5% threshold tolerance. Connect TOL to V _{CC} to select 10% threshold tolerance.
—	8, 9, 13, 14	N.C.	Not Internally Connected
—	—	EP	Exposed Pad. EP is internally connected to GND. Connect EP to the ground plane to provide a low thermal resistance path from the IC junction to the PCB. Do not use as the electrical connection to GND.

MAX16000–MAX16007

Low-Voltage, Quad-/Hex-/Octal-Voltage µP Supervisors

Table 1. Input-Voltage-Threshold Selector

PART	IN1	IN2	IN3	IN4	IN5	IN6	IN7	IN8
MAX16000A	3.3	2.5	ADJ	1.8	—	—	—	—
MAX16000B	3.3	ADJ	ADJ	1.8	—	—	—	—
MAX16000C	ADJ	2.5	ADJ	1.8	—	—	—	—
MAX16000D	3.3	2.5	ADJ	ADJ	—	—	—	—
MAX16000E	ADJ	ADJ	ADJ	ADJ	—	—	—	—
MAX16001A	3.3	2.5	ADJ	1.8	—	—	—	—
MAX16001B	3.3	ADJ	ADJ	1.8	—	—	—	—
MAX16001C	ADJ	2.5	ADJ	1.8	—	—	—	—
MAX16001D	3.3	2.5	ADJ	ADJ	—	—	—	—
MAX16001E	ADJ	ADJ	ADJ	ADJ	—	—	—	—
MAX16002A	3.3	2.5	ADJ	1.8	—	—	—	—
MAX16002B	3.3	ADJ	ADJ	1.8	—	—	—	—
MAX16002C	ADJ	2.5	ADJ	1.8	—	—	—	—
MAX16002D	3.3	2.5	ADJ	ADJ	—	—	—	—
MAX16002E	ADJ	ADJ	ADJ	ADJ	—	—	—	—
MAX16003A	3.3	2.5	ADJ	1.8	ADJ	ADJ	—	—
MAX16003B	3.3	ADJ	ADJ	1.8	ADJ	ADJ	—	—
MAX16003C	3.3	2.5	ADJ	ADJ	ADJ	ADJ	—	—
MAX16003D	ADJ	2.5	ADJ	1.8	ADJ	ADJ	—	—
MAX16003E	ADJ	ADJ	ADJ	ADJ	ADJ	ADJ	—	—
MAX16004A	3.3	2.5	ADJ	1.8	ADJ	ADJ	—	—
MAX16004B	3.3	ADJ	ADJ	1.8	ADJ	ADJ	—	—
MAX16004C	3.3	2.5	ADJ	ADJ	ADJ	ADJ	—	—
MAX16004D	ADJ	2.5	ADJ	1.8	ADJ	ADJ	—	—
MAX16004E	ADJ	ADJ	ADJ	ADJ	ADJ	ADJ	—	—
MAX16005A	3.3	2.5	ADJ	1.8	ADJ	ADJ	—	—
MAX16005B	3.3	ADJ	ADJ	1.8	ADJ	ADJ	—	—
MAX16005C	3.3	2.5	ADJ	ADJ	ADJ	ADJ	—	—
MAX16005D	ADJ	2.5	ADJ	1.8	ADJ	ADJ	—	—
MAX16005E	ADJ	ADJ	ADJ	ADJ	ADJ	ADJ	—	—
MAX16006A	3.3	2.5	ADJ	1.8	ADJ	ADJ	ADJ	ADJ
MAX16006B	3.3	ADJ	ADJ	1.8	ADJ	ADJ	ADJ	ADJ
MAX16006C	3.3	2.5	ADJ	ADJ	ADJ	ADJ	ADJ	ADJ
MAX16006D	ADJ	2.5	ADJ	1.8	ADJ	ADJ	ADJ	ADJ
MAX16006E	ADJ	ADJ	ADJ	ADJ	ADJ	ADJ	ADJ	ADJ
MAX16006F	5.0	3.3	3.0	2.5	1.8	1.5	1.2	0.9
MAX16007A	3.3	2.5	ADJ	1.8	ADJ	ADJ	ADJ	ADJ
MAX16007B	3.3	ADJ	ADJ	1.8	ADJ	ADJ	ADJ	ADJ
MAX16007C	3.3	2.5	ADJ	ADJ	ADJ	ADJ	ADJ	ADJ
MAX16007D	ADJ	2.5	ADJ	1.8	ADJ	ADJ	ADJ	ADJ
MAX16007E	ADJ	ADJ	ADJ	ADJ	ADJ	ADJ	ADJ	ADJ

Note: Other fixed thresholds may be available. Contact factory for availability.

MAX16000-MAX16007

Low-Voltage, Quad-/Hex-/Octal-Voltage μ P Supervisors

Functional Diagrams

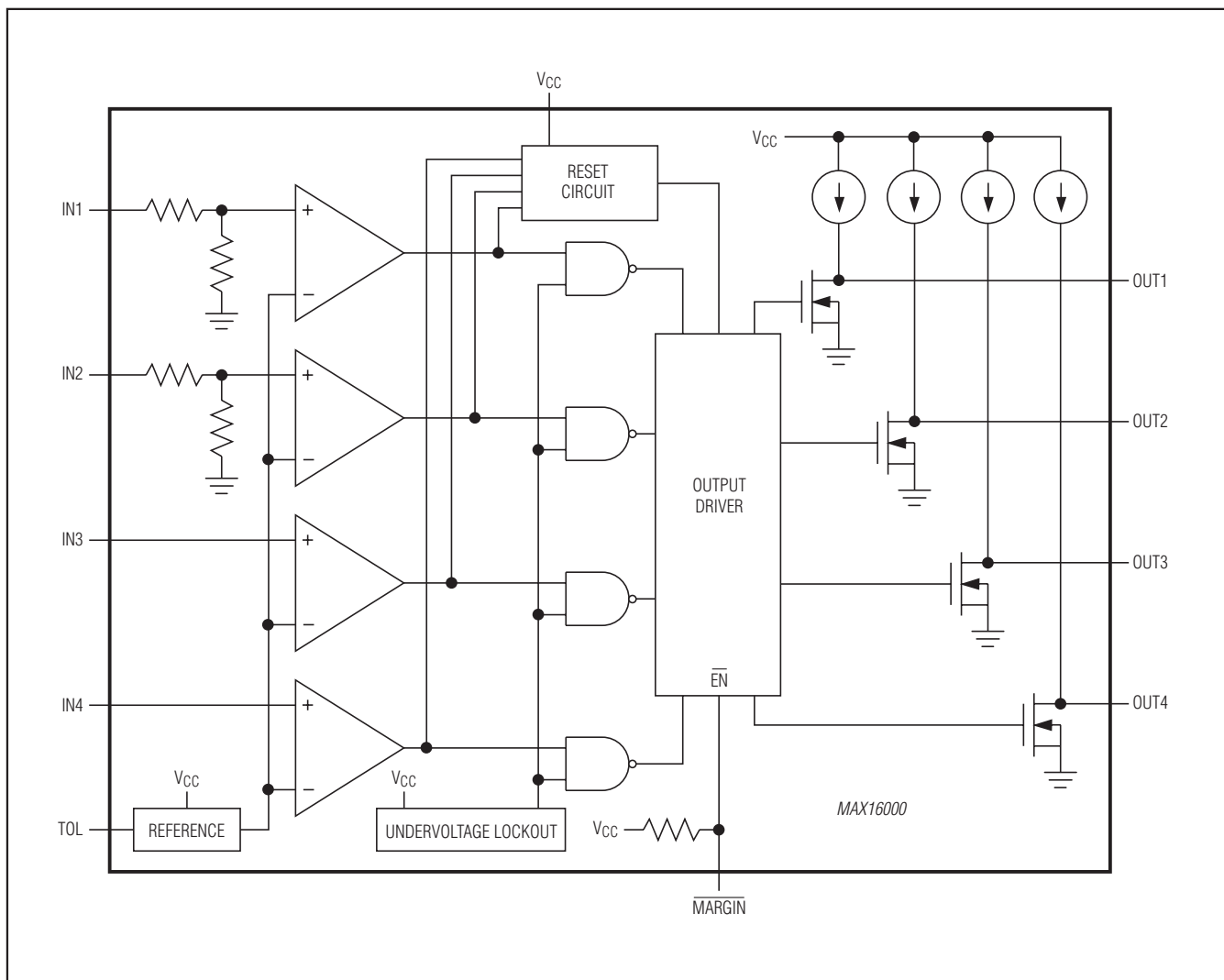

Figure 1. MAX16000D Functional Diagram

MAX16000-MAX16007

Low-Voltage, Quad-/Hex-/Octal-Voltage μ P Supervisors

Functional Diagrams (continued)

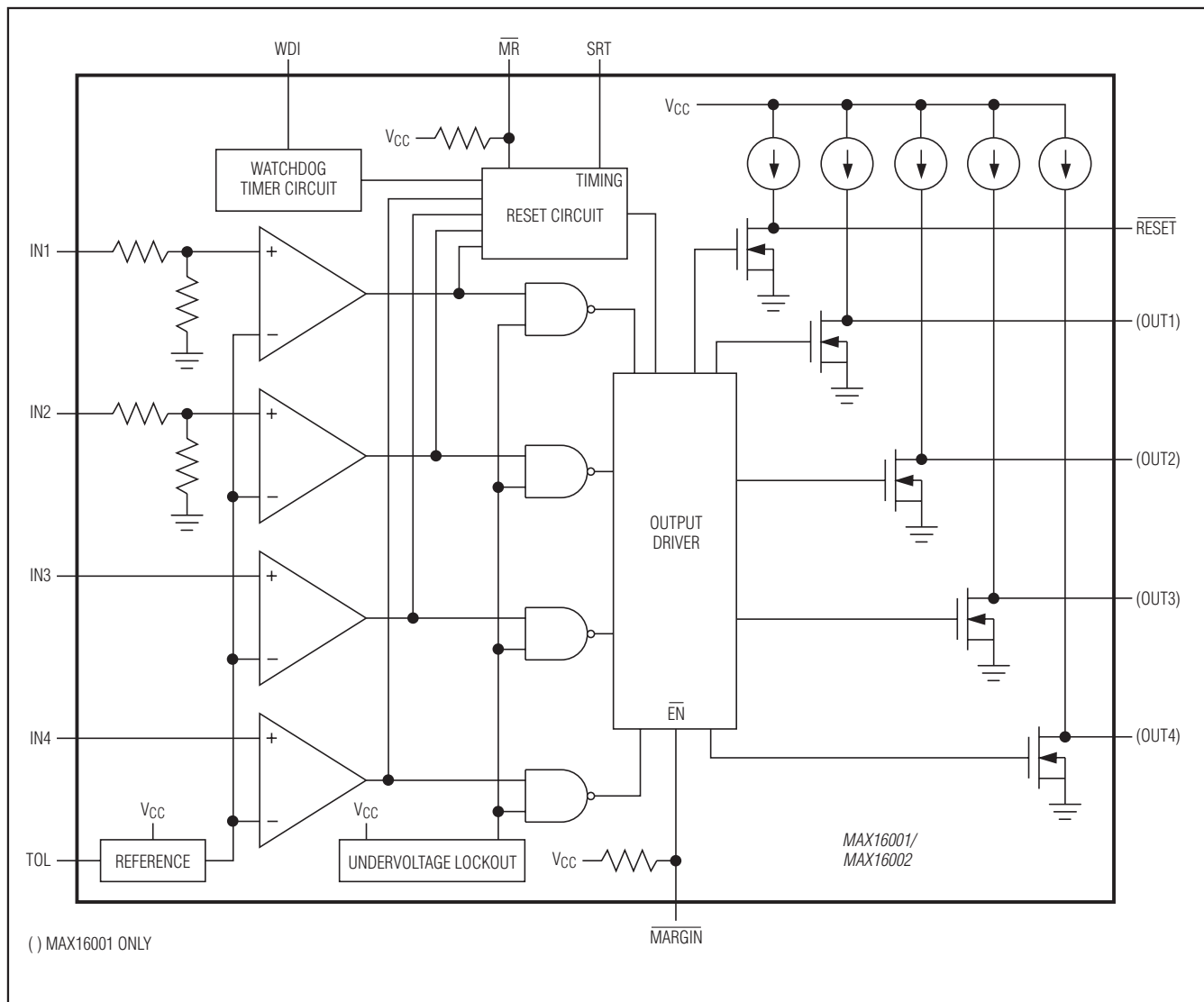

Figure 2. MAX16001D/MAX16002D Functional Diagram

MAX16000-MAX16007

Low-Voltage, Quad-/Hex-/Octal-Voltage μP Supervisors

Functional Diagrams (continued)

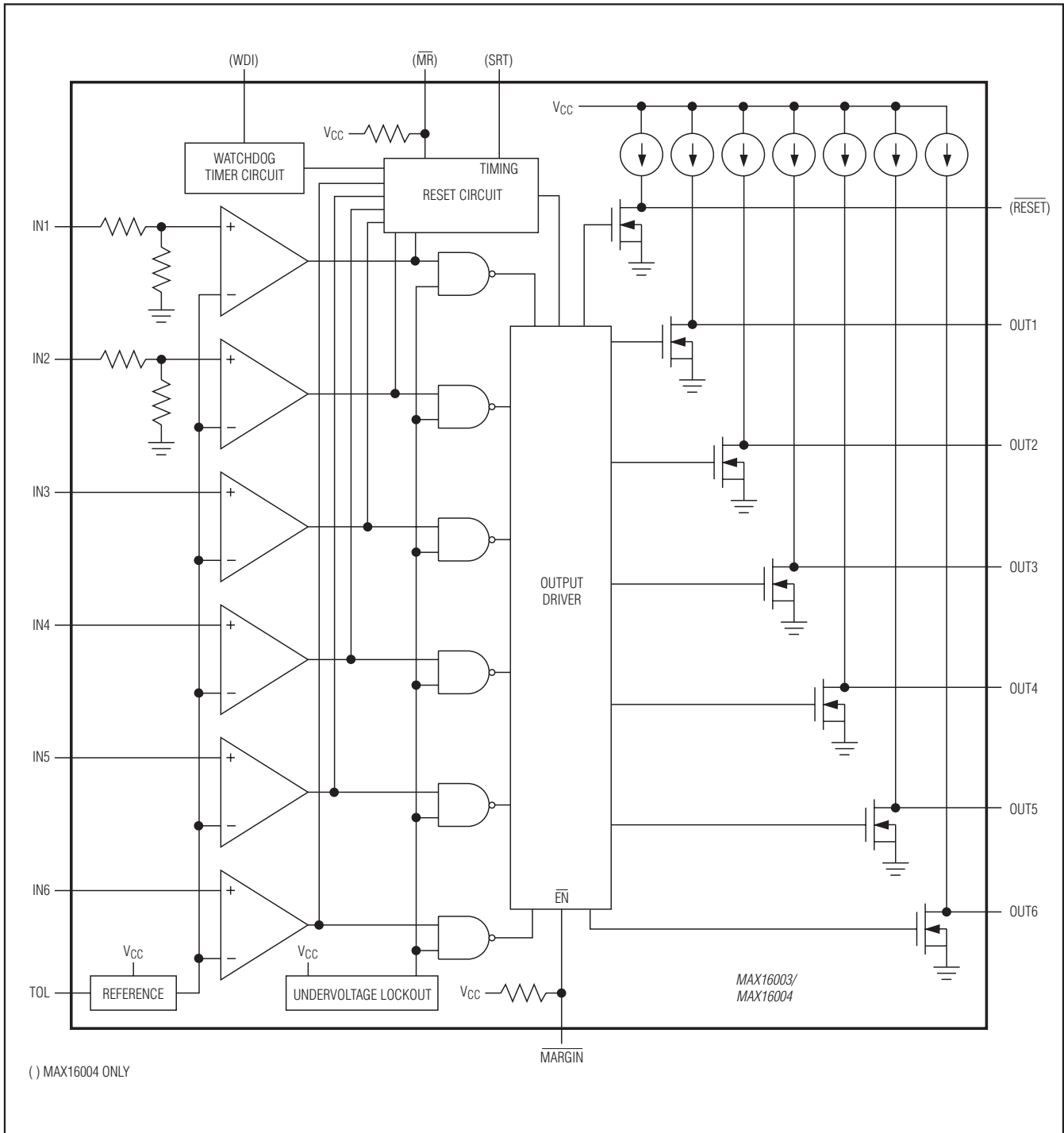

Figure 3. MAX16003C/MAX16004C Functional Diagram

MAX16000-MAX16007

Low-Voltage, Quad-/Hex-/Octal-Voltage μ P Supervisors

Functional Diagrams (continued)

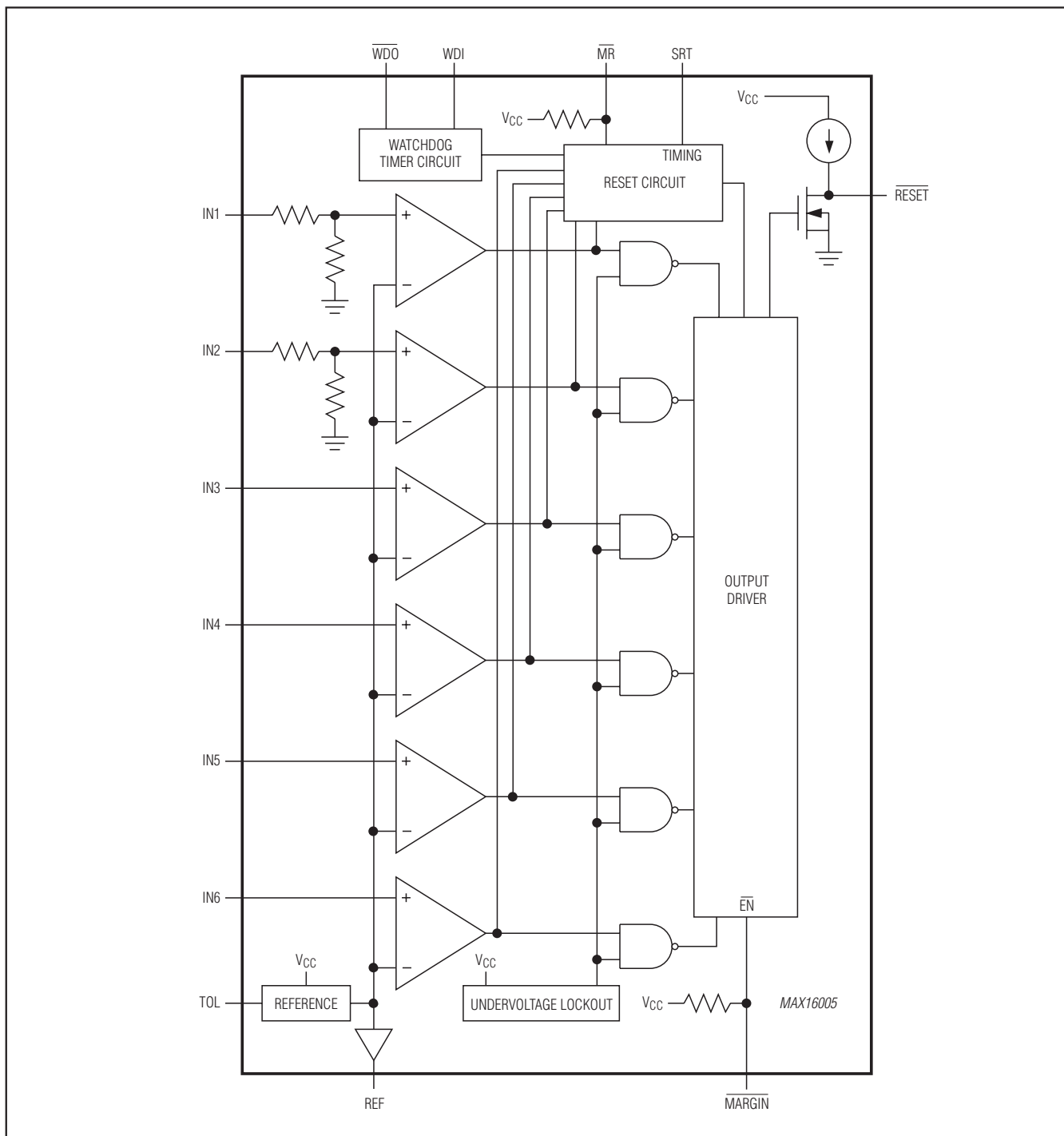

Figure 4. MAX16005C Functional Diagram

MAX16000-MAX16007

Low-Voltage, Quad-/Hex-/Octal-Voltage μP Supervisors

Functional Diagrams (continued)

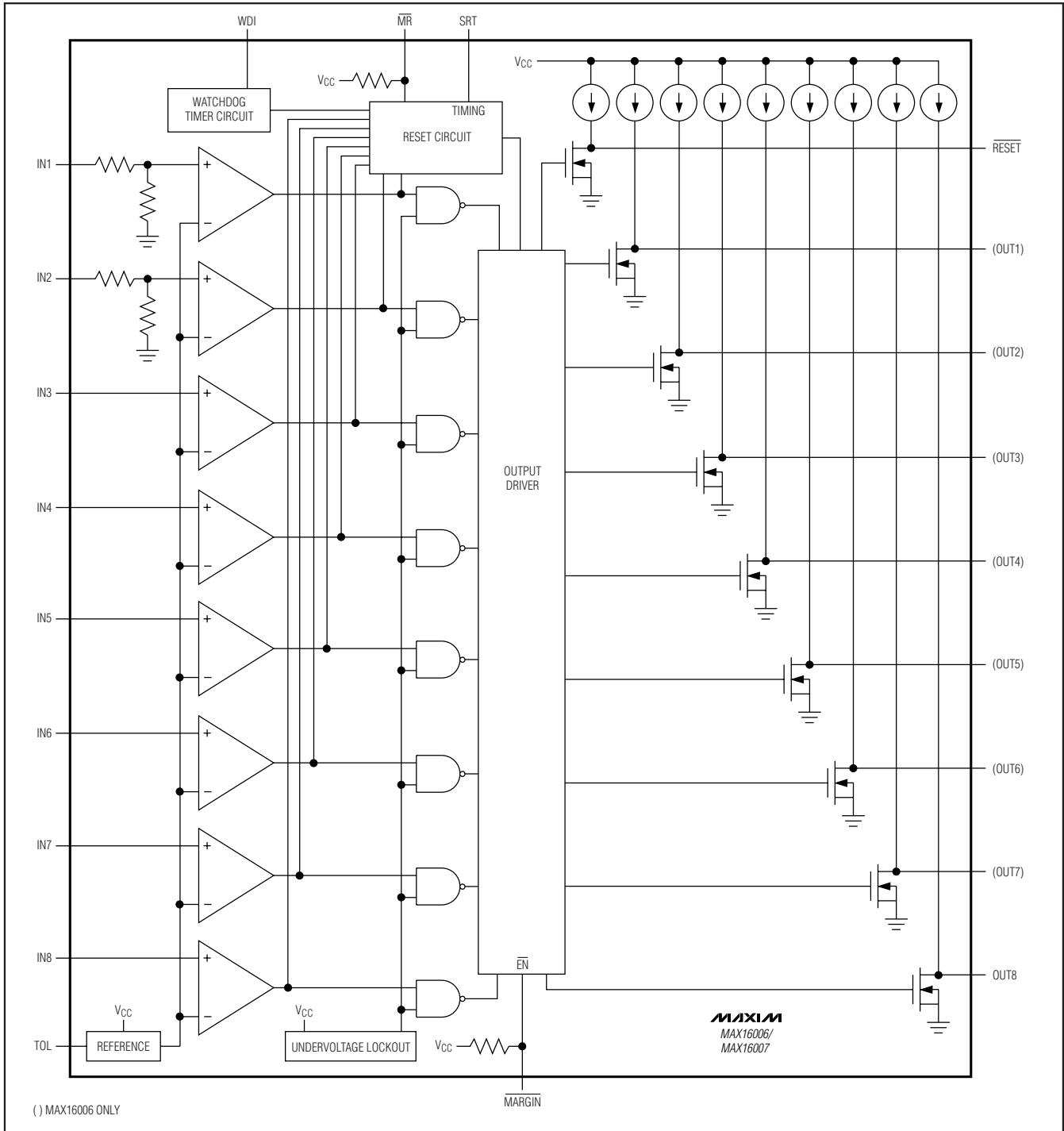

Figure 5. MAX16006C/MAX16007C Functional Diagram

MAX16000–MAX16007

Low-Voltage, Quad-/Hex-/Octal-Voltage μ P Supervisors

Detailed Description

The MAX16000–MAX16007 are low-voltage, quad-/hex-/octal-voltage μ P supervisors in small TQFN and TSSOP packages. These devices provide supervisory functions for complex multivoltage systems. The MAX16000/MAX16001/MAX16002 monitor four voltages, the MAX16003/MAX16004/MAX16005 monitor six voltages, and the MAX16006/MAX16007 monitor eight voltages.

The MAX16000/MAX16001/MAX16003/MAX16004/MAX16006 offer independent outputs for each monitored voltage. The MAX16001/MAX16002/MAX16004–MAX16007 offer a reset output that asserts whenever any of the monitored voltages fall below their respective thresholds or the manual reset input is asserted. The reset output remains asserted for the reset timeout after all voltages are above their respective thresholds and the manual reset input is deasserted. The minimum reset timeout is internally set to 140ms or can be adjusted with an external capacitor.

All open-drain outputs have internal 30 μ A pullups that eliminate the need for external pullup resistors. However, each output can be driven with an external voltage up to 5.5V. Other features offered include a manual reset input, a tolerance pin for selecting 5% or 10% input thresholds, and a margin enable function for deasserting the outputs during margin testing.

The MAX16001/MAX16002/MAX16004–MAX16007 offer a watchdog timer that asserts RESET or an independent watchdog output (MAX16005) when the watchdog timeout period (1.6s typ) is exceeded. The watchdog timer can be disabled by leaving input open.

Applications Information

Undervoltage-Detection Circuit

The open-drain outputs of the MAX16000–MAX16007 can be configured to detect an undervoltage condition. Figure 6 shows a configuration where an LED turns on when the comparator output is low, indicating an undervoltage condition. These devices can also be used in applications such as system supervisory monitoring, multivoltage level detection, and V_{CC} bar-graph monitoring (Figure 7).

Tolerance (TOL)

The MAX16000–MAX16007 feature a pin-selectable threshold tolerance. Connect TOL to GND to select 5% threshold tolerance. Connect TOL to V_{CC} to select 10% threshold tolerance.

Window Detection

A window detector circuit uses two auxiliary inputs in the configuration shown in Figure 8. External resistors set the two threshold voltages of the window detector circuit. External logic gates create the OUT signal. The window detection width is the difference between the threshold voltages (Figure 9).

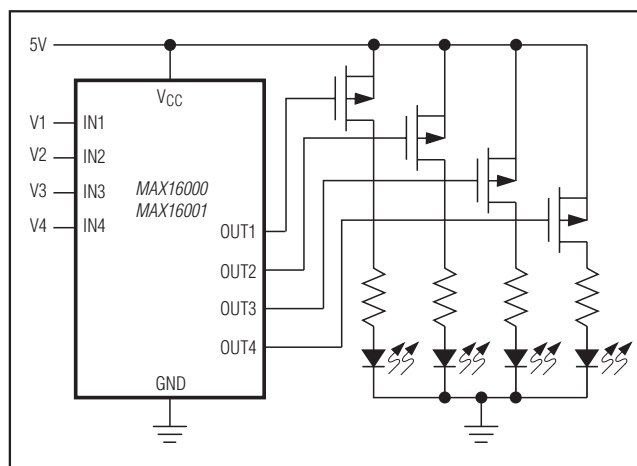

Figure 6. Quad Undervoltage Detector with LED Indicators

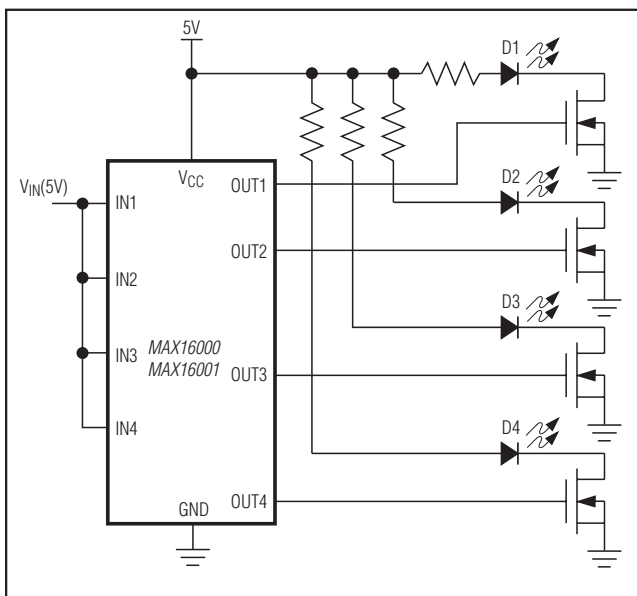

Figure 7. V_{CC} Bar-Graph Monitoring

MAX16000–MAX16007

Low-Voltage, Quad-/Hex-/Octal-Voltage μ P Supervisors

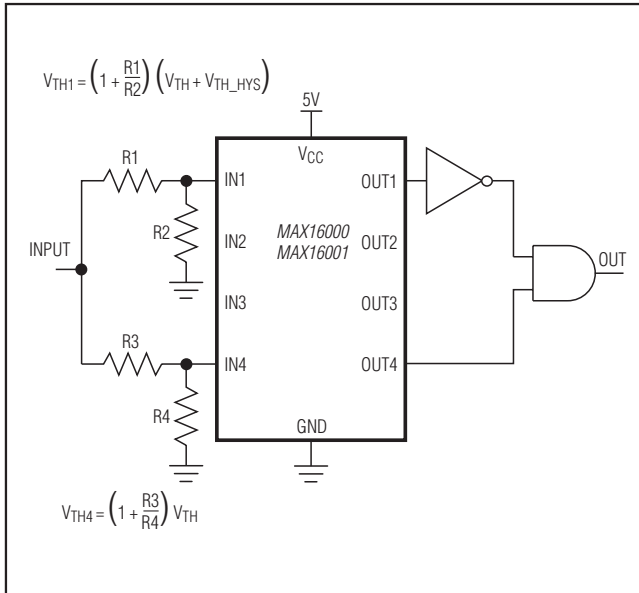

Figure 8. Window Detection

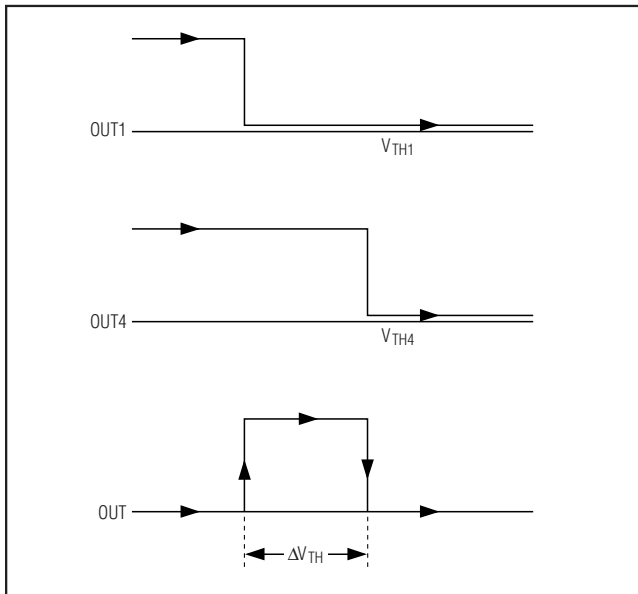

Figure 9. Output Response of Window Detector Circuit

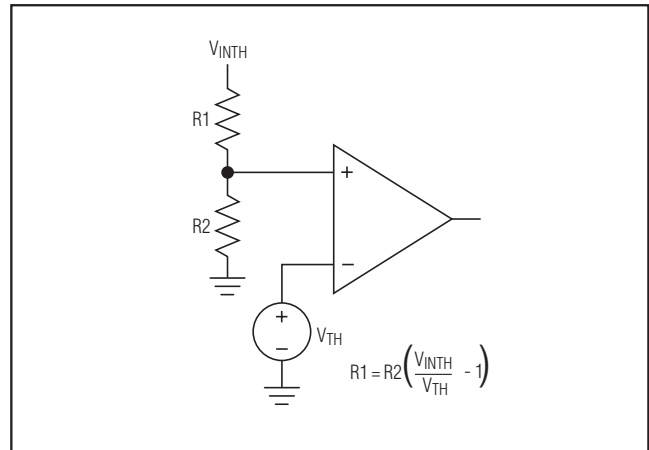

Figure 10. Setting the Adjustable Input

Adjustable Input

These devices offer several monitor options with adjustable input thresholds (see Table 1). The threshold voltage at each adjustable IN_ input is typically 0.394V (TOL = GND) or 0.372 (TOL = VCC). To monitor a voltage V_{INTH}, connect a resistive-divider network to the circuit as shown in Figure 10.

$$V_{INTH} = V_{TH} \left(\frac{R1}{R2} + 1 \right)$$

$$R1 = R2 \left(\frac{V_{INTH}}{V_{TH}} - 1 \right)$$

Large resistors can be used to minimize current through the external resistors. For greater accuracy, use lower-value resistors.

Unused Inputs

Connect any unused IN_ inputs to a voltage above its threshold.

OUT_ Outputs (MAX16000/MAX16001/MAX16003/ MAX16004/MAX16006)

The OUT_ outputs go low when their respective IN_ inputs drop below their specified thresholds. The output is open drain with a 30 μ A internal pullup to VCC. For many applications, no external pullup resistor is required to interface with other logic devices. An external pullup resistor to any voltage from 0 to 5.5V overrides the internal pullup if interfacing to different logic supply voltages. Internal circuitry prevents reverse current flow from the external pullup voltage to VCC (Figure 11).

MAX16000–MAX16007

Low-Voltage, Quad-/Hex-/Octal-Voltage μ P Supervisors

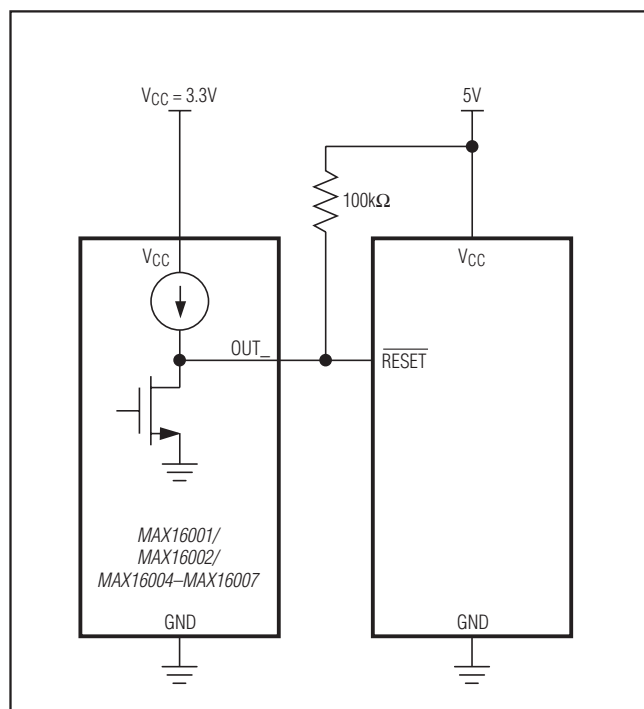

Figure 11. Interfacing to a Different Logic Supply Voltage

$\overline{\text{RESET}}$ Output (MAX16001/MAX16002/ MAX16004–MAX16007)

$\overline{\text{RESET}}$ asserts low when any of the monitored voltages fall below their respective thresholds or $\overline{\text{MR}}$ is asserted. $\overline{\text{RESET}}$ remains asserted for the reset timeout period after all monitored voltages exceed their respective thresholds and $\overline{\text{MR}}$ is deasserted (see Figure 12). This open-drain output has a 30 μ A internal pullup. An external pullup resistor to any voltage from 0 to 5.5V overrides the internal pullup if interfacing to different logic supply voltages. Internal circuitry prevents reverse current flow from the external pullup voltage to VCC (Figure 11).

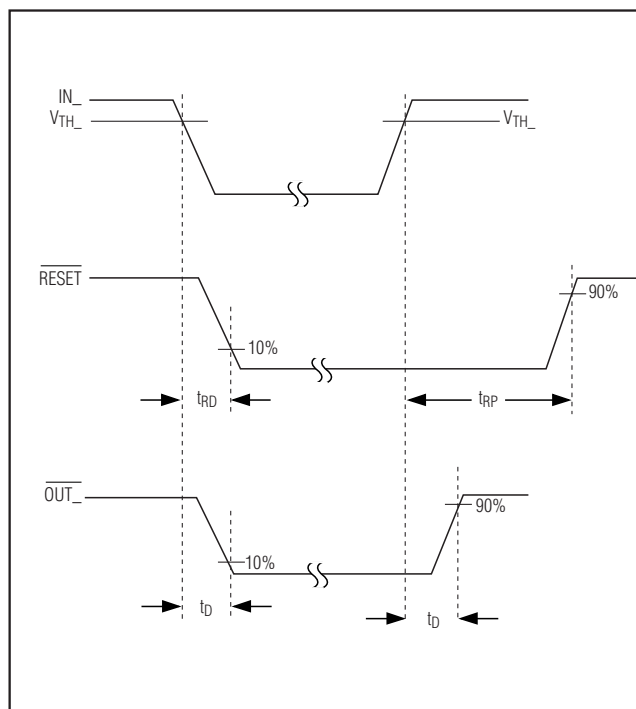

Figure 12. Output Timing Diagram

$\overline{\text{WDO}}$ (MAX16005 Only)

$\overline{\text{WDO}}$ asserts and stays low whenever any of the IN_ inputs fall below their respective thresholds. $\overline{\text{WDO}}$ deasserts without a timeout delay when all the IN_ inputs rise above their thresholds. When all the IN_ inputs rise above their thresholds, $\overline{\text{WDO}}$ asserts low whenever the watchdog timer times out. $\overline{\text{WDO}}$ deasserts after a valid WDI transition or if $\overline{\text{MR}}$ is pulled low. The watchdog timer begins counting after the reset timeout period once $\overline{\text{MR}}$ goes high. Pull MARGIN low to deassert $\overline{\text{WDO}}$ regardless of any other condition. The watchdog timer continues to run when MARGIN is low and if a timeout occurs. $\overline{\text{WDO}}$ will assert $\overline{\text{MR}}$ after MARGIN is deasserted. This open-drain output has a 30 μ A internal pullup. An external pullup resistor to any voltage from 0 to 5.5V overrides the internal pullup if interfacing to different logic supply voltages. Internal circuitry prevents reverse current flow from the external pullup voltage to VCC (Figure 11).

MAX16000-MAX16007

Low-Voltage, Quad-/Hex-/Octal-Voltage μ P Supervisors

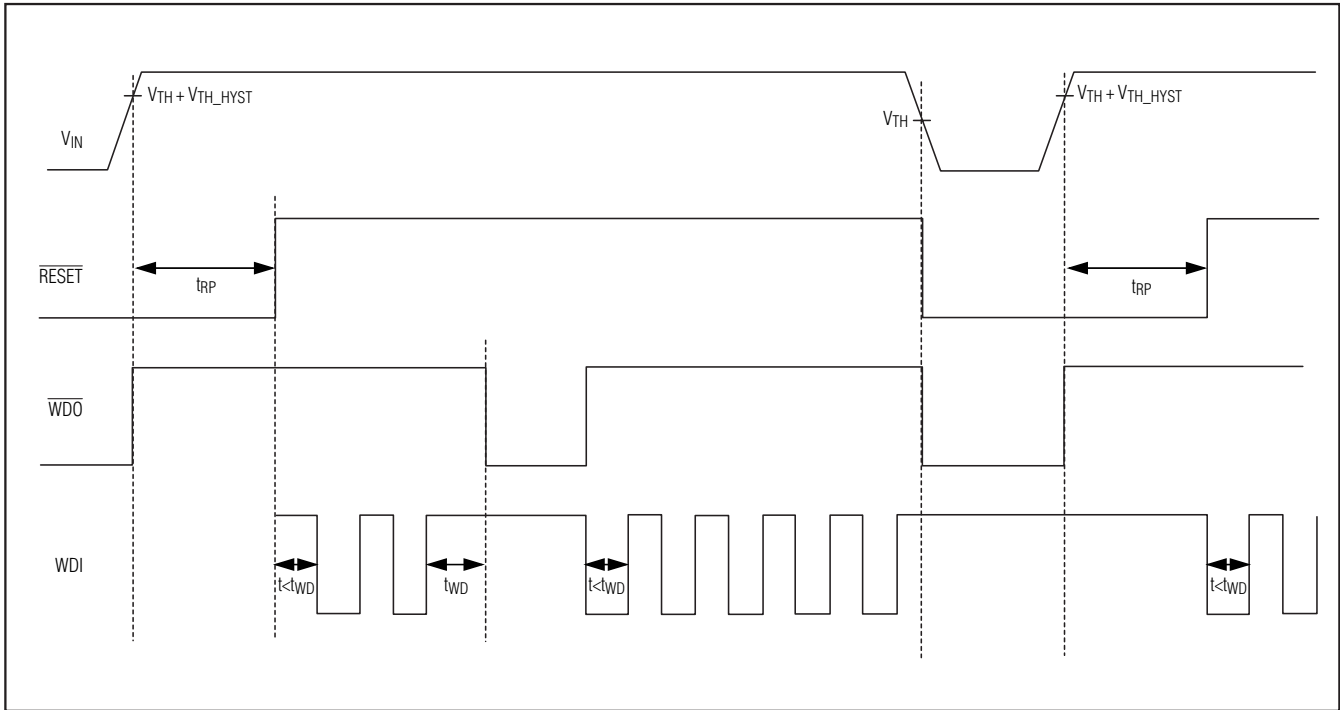

Figure 13. \overline{WDO} Timing Related to V_{TH} and t_{RP}

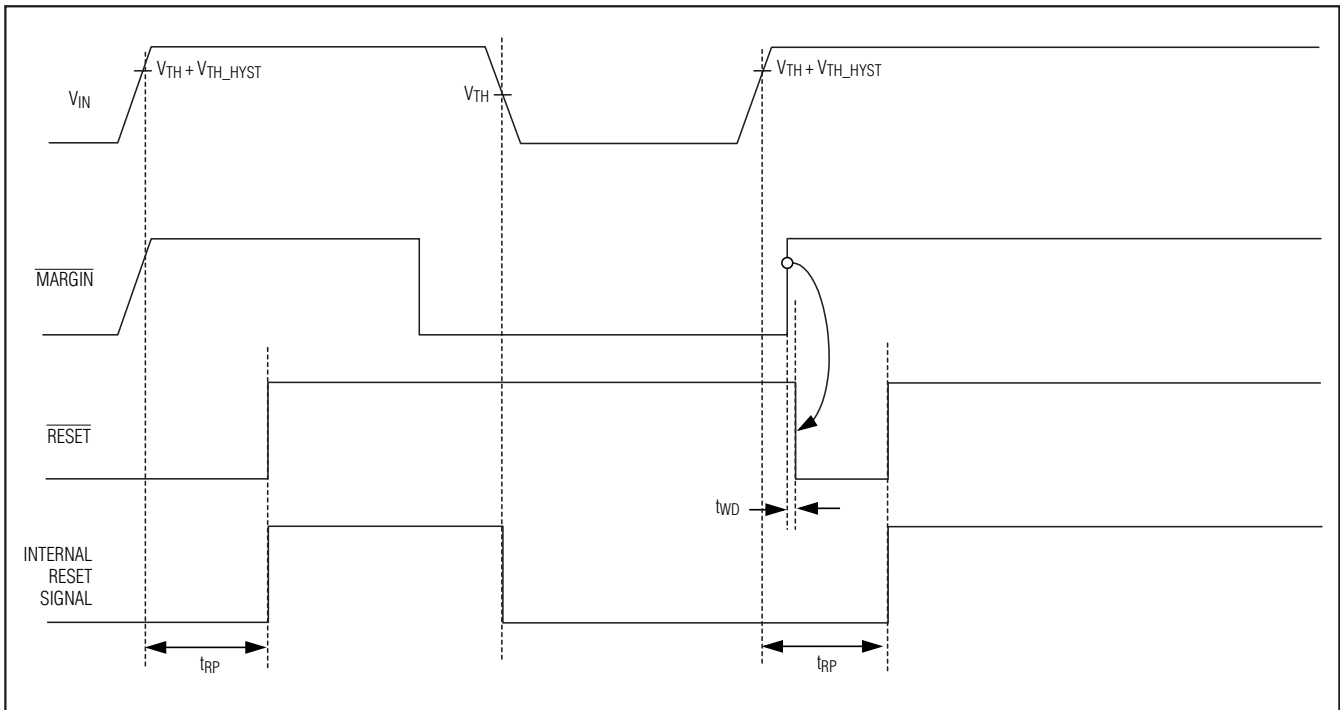

Figure 14. Margin Output Disable (\overline{MARGIN}) Affect on \overline{RESET} within t_{RP}

MAX16000–MAX16007

Low-Voltage, Quad-/Hex-/Octal-Voltage μ P Supervisors

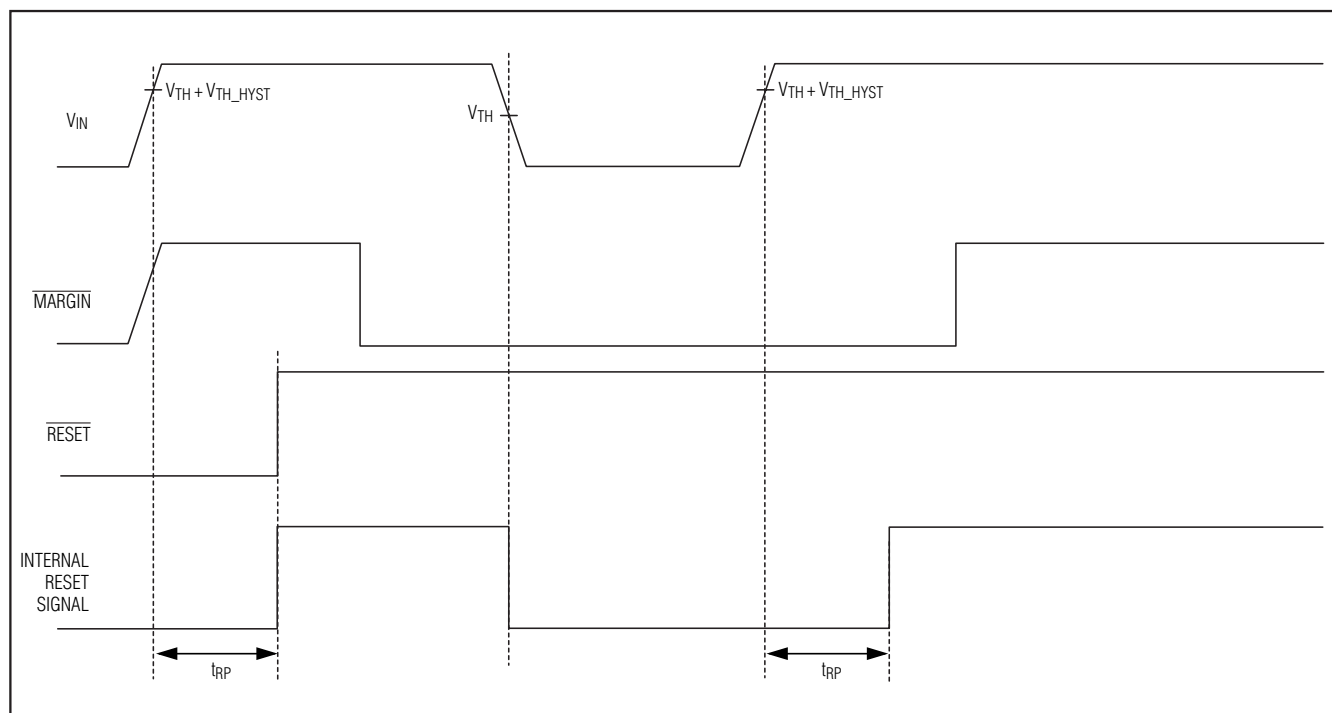

Figure 15. Margin Output Disable (\overline{MARGIN}) Affect on \overline{RESET} Outside t_{RP}

Reset Timeout Capacitor

The reset timeout period can be adjusted to accommodate a variety of μ P applications from 50 μ s to 1.12s. Adjust the reset timeout period (t_{RP}) by connecting a capacitor (C_{SRT}) between SRT and GND. Calculate the reset timeout capacitor as follows:

$$C_{SRT} (F) = \frac{t_{RP} (s) \times I_{SRT}}{V_{TH_SRT}}$$

Connect SRT to V_{CC} for a factory-programmed reset timeout of 140ms (min).

Manual Reset Input (MR) (MAX16001/MAX16002/ MAX16004–MAX16007)

Many μ P-based products require manual reset capability, allowing the operator, a test technician, or external logic circuitry to initiate a reset. A logic-low on \overline{MR} asserts \overline{RESET} low. \overline{RESET} remains asserted while \overline{MR} is low, and during the reset timeout period (140ms min) after \overline{MR} returns high. The \overline{MR} input has an internal 20k Ω pullup resistor to V_{CC} , so it can be left unconnected if not used. \overline{MR} can be driven with TTL or CMOS-logic levels, or with open-drain/collector outputs. Connect a normally open momentary switch from

\overline{MR} to GND to create a manual reset function. External debounce circuitry is not required. If \overline{MR} is driven from long cables or if the device is used in a noisy environment, connecting a 0.1 μ F capacitor from \overline{MR} to GND provides additional noise immunity.

Margin Output Disable (\overline{MARGIN})

\overline{MARGIN} allows system-level testing while power supplies are adjusted from their nominal voltages. Drive \overline{MARGIN} low to force \overline{RESET} , \overline{WDO} , and \overline{OUT} high, regardless of the voltage at any monitored input. The state of each output does not change while $\overline{MARGIN} = \text{GND}$. The watchdog timer continues to run when \overline{MARGIN} is low, and if a timeout occurs, $\overline{WDO}/\overline{RESET}$ will assert t_{MD} after \overline{MARGIN} is deasserted.

The \overline{MARGIN} input is internally pulled up to V_{CC} . Leave \overline{MARGIN} unconnected or connect to V_{CC} if unused.

Power-Supply Bypassing

The MAX16000–MAX16007 operate from a 2.0V to 5.5V supply. An undervoltage lockout ensures that the outputs are in the correct states when the UVLO is exceeded. In noisy applications, bypass V_{CC} to ground with a 0.1 μ F capacitor as close to the device as possible. The additional capacitor improves transient immunity. For V_{CC} transients with high slew rates, place an RC low-pass filter in front of V_{CC} , where R can be up to 100 Ω .

MAX16000–MAX16007

Low-Voltage, Quad-/Hex-/Octal-Voltage μP Supervisors

Pin Configurations

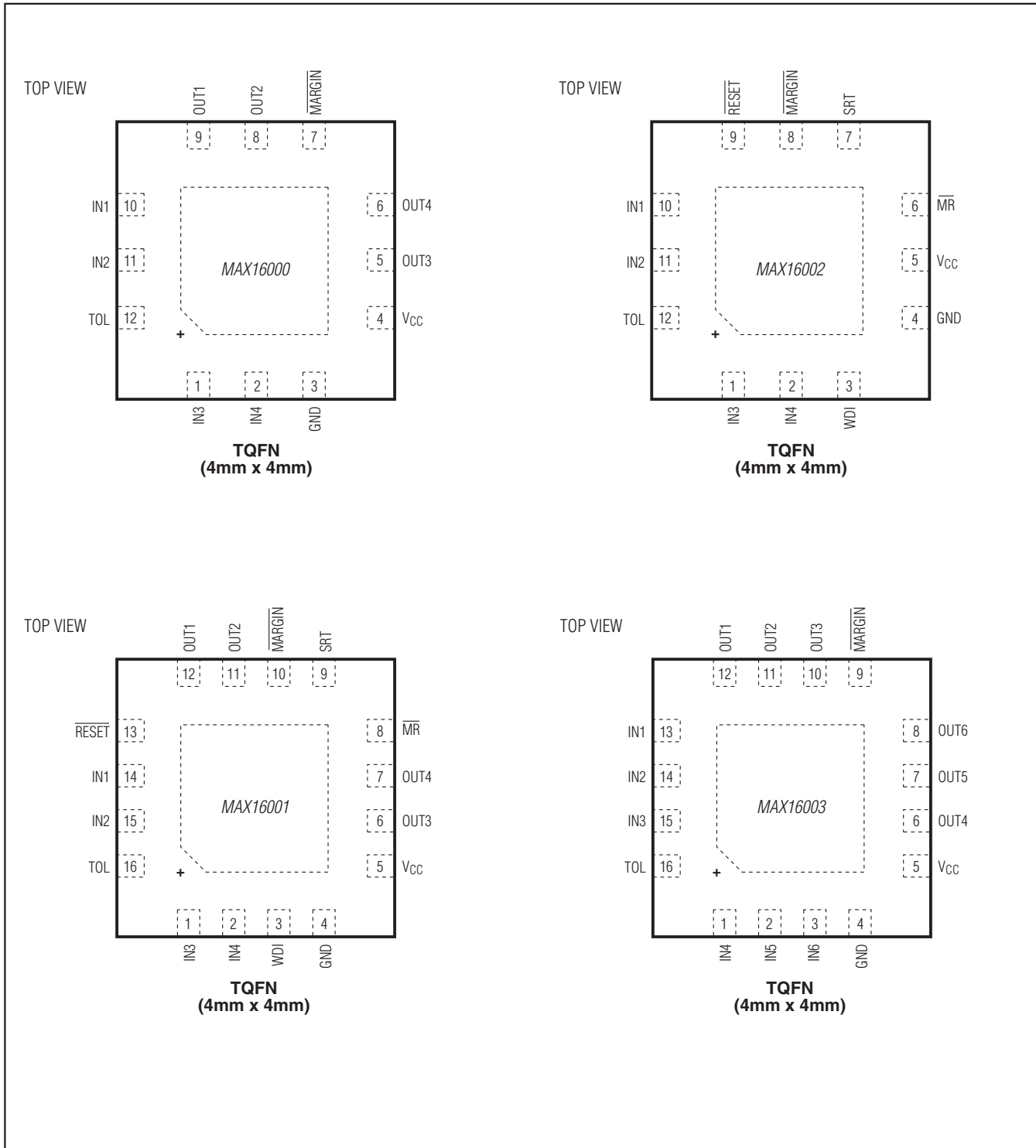

MAX16000–MAX16007

Low-Voltage, Quad-/Hex-/Octal-Voltage μ P Supervisors

Pin Configurations (continued)

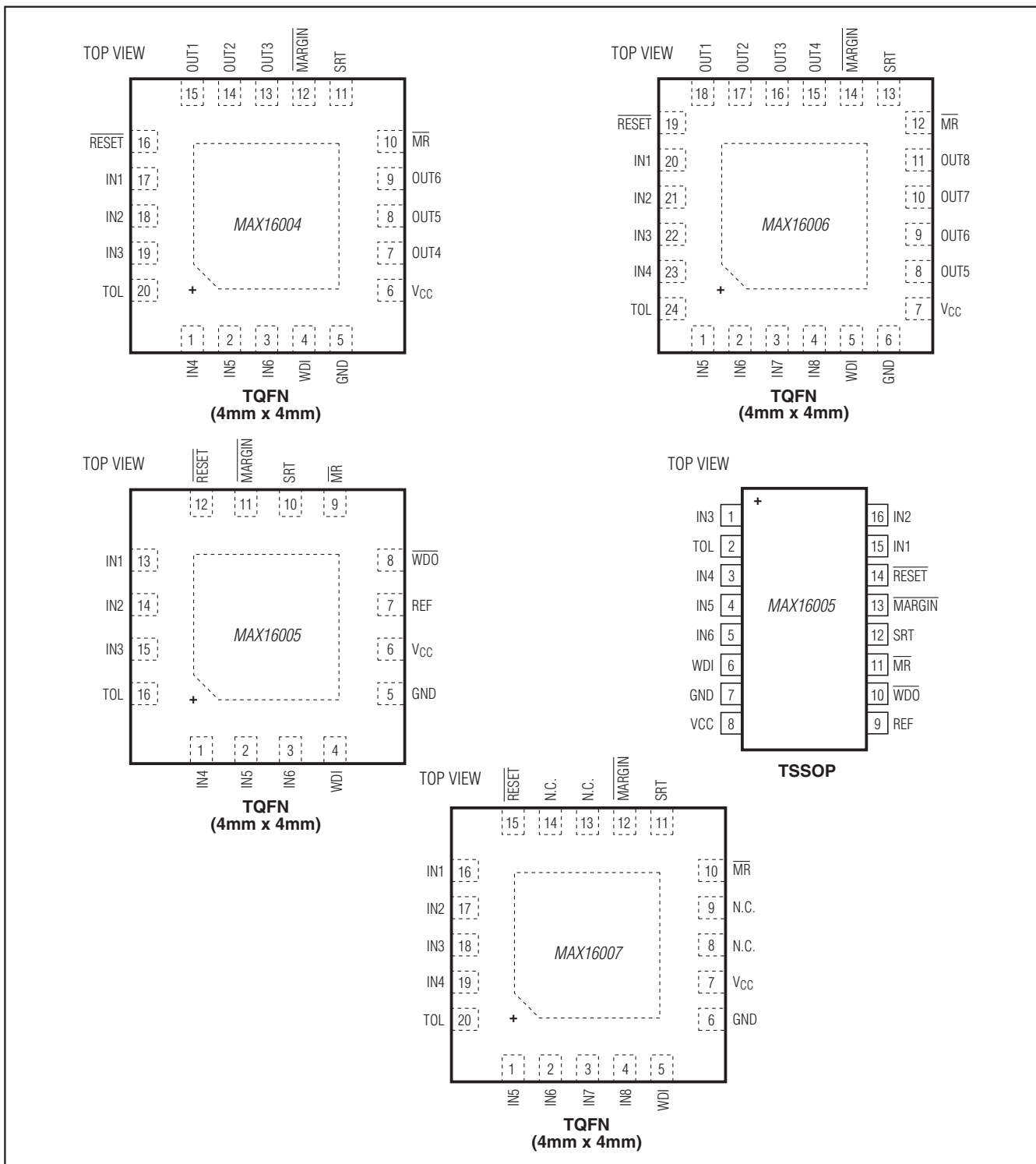

MAX16000–MAX16007

Low-Voltage, Quad-/Hex-/Octal-Voltage μP Supervisors

Ordering Information (continued)

PART	TEMP RANGE	PIN-PACKAGE
MAX16001_TE+	-40°C to +125°C	16 TQFN-EP*
MAX16001_TE/V+	-40°C to +125°C	16 TQFN-EP*
MAX16002_TC+	-40°C to +125°C	12 TQFN-EP*
MAX16003_TE+	-40°C to +125°C	16 TQFN-EP*
MAX16004_TP+	-40°C to +125°C	20 TQFN-EP*
MAX16005_TE+	-40°C to +125°C	16 TQFN-EP*
MAX16005_UE+	-40°C to +125°C	16 TSSOP
MAX16006_TG+	-40°C to +125°C	24 TQFN-EP*
MAX16007_TP+	-40°C to +125°C	20 TQFN-EP*

Note: The “_” is a placeholder for the input voltage threshold. See Table 1.

+Denotes a lead(Pb)-free/RoHS-compliant package.

For tape-and-reel, add a “T” after the “+.” Tape-and-reel are offered in 2.5k increments.

*EP = Exposed pad.

V denotes an automotive qualified part.

Chip Information

PROCESS: BICMOS

Selector Guide

PART	MONITORED VOLTAGES	INDEPENDENT OUTPUTS	RESET	WDI/WDO	MR	ADJUSTABLE RESET TIMEOUT
MAX16000	4	4	—	—	—	—
MAX16001	4	4	✓	WDI	✓	✓
MAX16002	4	—	✓	WDI	✓	✓
MAX16003	6	6	—	—	—	—
MAX16004	6	6	✓	WDI	✓	✓
MAX16005	6	—	✓	WDI/WDO	✓	✓
MAX16006	8	8	✓	WDI	✓	✓
MAX16007	8	—	✓	WDI	✓	✓

Package Information

For the latest package outline information and land patterns (footprints), go to www.maximintegrated.com/packages. Note that a “+”, “#”, or “.” in the package code indicates RoHS status only. Package drawings may show a different suffix character, but the drawing pertains to the package regardless of RoHS status.

PACKAGE TYPE	PACKAGE CODE	OUTLINE NO.	LAND PATTERN NO.
12 TQFN-EP	T1244+4	21-0139	90-0068
16 TSSOP	U16+2	21-0066	90-0117
16 TQFN-EP	T1644+4	21-0139	90-0070
20 TQFN-EP	T2044+3	21-0139	90-0037
24 TQFN-EP	T2444+4	21-0139	90-0022