



Chipsmall Limited consists of a professional team with an average of over 10 year of expertise in the distribution of electronic components. Based in Hongkong, we have already established firm and mutual-benefit business relationships with customers from,Europe,America and south Asia,supplying obsolete and hard-to-find components to meet their specific needs.

With the principle of “Quality Parts,Customers Priority,Honest Operation,and Considerate Service”,our business mainly focus on the distribution of electronic components. Line cards we deal with include Microchip,ALPS,ROHM,Xilinx,Pulse,ON,Everlight and Freescale. Main products comprise IC,Modules,Potentiometer,IC Socket,Relay,Connector.Our parts cover such applications as commercial,industrial, and automotives areas.

We are looking forward to setting up business relationship with you and hope to provide you with the best service and solution. Let us make a better world for our industry!



Contact us

Tel: +86-755-8981 8866 Fax: +86-755-8427 6832

Email & Skype: info@chipsmall.com Web: www.chipsmall.com

Address: A1208, Overseas Decoration Building, #122 Zhenhua RD., Futian, Shenzhen, China





MAX16807 Evaluation Kit

Evaluates: MAX16807

General Description

The MAX16807 evaluation kit (EV kit) is an 8-channel, constant-current LED driver, capable of driving 50mA through each channel and adapting the channel-supply voltage. Each channel can be used to drive a string of LEDs with a total forward voltage of up to 32V. The EV kit features a MAX16807 IC that integrates eight constant-current sinking outputs and a high-performance, current-mode pulse-width modulator (PWM) controller for implementing a DC-DC power converter that generates the supply voltage to drive LED strings connected to each channel by the user. The sink current for the eight channels is configurable using a single resistor.

The MAX16807 EV kit operates with supply voltages up to 16V. The EV kit circuit also features PWM dimming and shutdown control input PC pads. The MAX16807 EV kit is a fully assembled and tested board.

Features

- ◆ Up to 16V Supply Voltage Range
- ◆ 50mA Output Current per Channel
- ◆ Single Resistor Current Adjust for Eight Channels
- ◆ Up to 32V LED Forward String Voltage
- ◆ Boost Converter to Generate LED Voltage
- ◆ Adaptive LED Voltage Control Increases Efficiency
- ◆ PWM Dimming and Shutdown Control Inputs
- ◆ Proven PCB Layout
- ◆ Fully Assembled and Tested

Ordering Information

PART	TEMP RANGE	IC PACKAGE
MAX16807EVKIT+	0°C to +70°C*	28 TSSOP-EP**

+Denotes a lead-free and RoHS-compliant EV kit.

*This limited temperature range applies to the EV kit PCB only. The MAX16807 IC temperature range is -40°C to +125°C.

**EP = Exposed paddle.

Component List

DESIGNATION	QTY	DESCRIPTION
C1, C2	2	22 μ F \pm 20%, 50V electrolytic capacitors (D-case) Panasonic EEEFK1H220P
C3, C4, C12, C13, C15	5	0.1 μ F \pm 10%, 50V X7R ceramic capacitors (0603) Murata GRM188R71H104K TDK C1608X7R1H104K
C5	1	560pF \pm 5%, 50V C0G ceramic capacitor (0603) Murata GRM1885C1H561J TDK C1608C0G1H561J
C6	1	150pF \pm 5%, 50V C0G ceramic capacitor (0603) Murata GRM1885C1H151J TDK C1608C0G1H151J
C7	1	10pF \pm 5%, 50V C0G ceramic capacitor (0603) Murata GRM1885C1H100J TDK C1608C0G1H100J
C8	1	100pF \pm 10%, 50V C0G ceramic capacitor (0603) Murata GRM1885C1H101K TDK C1608C0G1H101K

DESIGNATION	QTY	DESCRIPTION
C9	1	1 μ F \pm 10%, 50V X7R ceramic capacitor (1206) Murata GRM31MR71H105K TDK C3216X7R1H105K
C10, C11	2	22 μ F \pm 20%, 35V electrolytic capacitors (C-case) Panasonic EEEFK1V220R
C14	1	1 μ F \pm 10%, 16V X5R ceramic capacitor (0603) Murata GRM188R61C105K TDK C1608X5R1C105K
C16	1	0.01 μ F \pm 10%, 50V X7R ceramic capacitor (0603) Murata GRM188R71H103K TDK C1608X7R1H103K
C17–C24	8	1000pF \pm 10%, 50V X7R ceramic capacitors (0603) Murata GRM188R71H102K TDK C1608X7R1H102K
C25	0	Not installed, ceramic capacitor (0603)

MAX16807 Evaluation Kit

Component List (continued)

DESIGNATION	QTY	DESCRIPTION
D1	1	40V, 1A Schottky diode (SMA) Central Semiconductor CMSH1-40ML LEAD FREE
D2-D5	4	6.2V dual zener diodes (SOT23) Diodes Inc. AZ23C6V2-7-F
D6	1	30V, 30mA Schottky diode (SOD523) Diodes Inc. SDM03U40
D7	1	75V, 300mA fast switching diode (SOD323) Diodes Inc. 1N4148WS
D8	1	33V zener diode (SOD323) Diodes Inc. MMSZ5257BS
J1	1	10-pin header
L1	1	33 μ H, 2.3A inductor Coilcraft MSS1038-333ML
N1	1	40V, 3.5A n-channel MOSFET (SOT23) Vishay Si2318DS-E3
Q1	1	40V, 600mA npn small signal transistor (SOT523) Diodes Inc. MMBT2222AT
R1	1	200k Ω \pm 1% resistor (0603)
R2	1	8.45k Ω \pm 1% resistor (0603)

DESIGNATION	QTY	DESCRIPTION
R3	1	15 Ω \pm 5% resistor (0603)
R4, R13	2	22k Ω \pm 1% resistors (0603)
R5	1	1.2k Ω \pm 1% resistor (0603)
R6	1	17.4k Ω \pm 1% resistor (0603)
R7	1	365 Ω \pm 1% resistor (0603)
R8	0	Not installed, resistor (1206)
R9	1	0.11 Ω \pm 1%, 0.5W resistor (1206) IRC, Inc. LRC-LR1206LF-01-R110-F
R10	1	330k Ω \pm 1% resistor (0603)
R11	1	75k Ω \pm 1% resistor (0603)
R12, R15	2	10k Ω \pm 1% resistors (0603)
R14	1	2.21k Ω \pm 1% resistor (0603)
U1	1	MAX16807AUI+ (28-pin TSSOP-EP)
U2	1	Dual Schmitt trigger inverter (SC70-6) TI SN74LVC2G14DCKT
U3	1	-50V, -100mA pnp digital transistor (SC59) Diodes Inc. DDTA114WKA
U4	1	50V, 100mA npn digital transistor (SC59) Diodes Inc. DDTC114WKA
---	1	PCB: MAX16807 Evaluation Kit+

Component Suppliers

SUPPLIER	PHONE	WEBSITE
Central Semiconductor	631-435-1110	www.centralsemi.com
Coilcraft, Inc.	847-639-6400	www.coilcraft.com
Diodes Inc.	805-446-4800	www.diodes.com
IRC, Inc.	361-992-7900	www.irctt.com
Murata Mfg. Co., Ltd	770-436-1300	www.murata.com
TDK Corp.	847-803-6100	www.component.tdk.com
Panasonic Corp.	800-344-2112	www.panasonic.com
Vishay	203-268-6261	www.vishay.com

Note: Indicate that you are using the MAX16807 when contacting these component suppliers.

MAX16807 Evaluation Kit

Evaluates: MAX16807

Quick Start

Recommended Equipment

- One 16V, 2A adjustable power supply
- One 5V power supply
- One voltmeter
- Eight LED strings with a total forward voltage rating $\leq 32V$ (optional)
- One PWM signal generator (optional)

Procedure

The MAX16807 EV kit is a fully assembled and tested surface-mount printed circuit board (PCB). Follow the steps below to verify board operation. **Caution: Do not enable the power supply until all connections are made.**

- 1) Adjust the 16V power supply output to 12V. Connect this power supply between the EV kit's VIN and GND pads.
- 2) Connect the 5V power supply between the EV kit's VBIAS and GND pads.
- 3) Connect the $\overline{\text{SHDN}}$ pad to the VIN pad.
- 4) Enable both power supplies.
- 5) Use the voltmeter to verify that the voltage at header J1, pins J1-1 and J1-2, referencing GND, measures approximately 36V.
- 6) Disable the VIN power-supply output.
- 7) Connect the anode of each LED string to VLED (pins J1-1 and J1-2). Connect the cathode of each LED string to channels OUT0–OUT7 (pins J1-3–J1-10).
- 8) Enable the VIN power-supply output.
- 9) Verify that all LEDs are illuminating.
- 10) Connect a PWM signal with amplitude of 5V and a frequency between 100Hz and 2kHz to the PWM input PC pad. The LED brightness should increase as the PWM signal's duty cycle increases and vice versa.

Detailed Description

This EV kit evaluates the MAX16807 IC, which has two major sections. The first section consists of eight constant-current LED drivers for LED strings. Each driver can sink up to 55mA through an LED string when ON

and block up to 36V when OFF. The second section is a high-performance, current-mode PWM controller that controls a power converter to generate a voltage for driving the LED strings. The EV kit uses the PWM controller to drive a boost-converter circuit, which takes a 9V to 16V input and generates up to 36V LED voltage at header pins J1-1 and J1-2 (VLED). To drive the LED string with constant current, connect the LED string between the VLED output and any of the eight constant-current sink outputs. The sink current of each output is configured to 50mA with resistor R7.

The LED voltage generated by the boost converter on the MAX16807 EV kit is adaptive. The LED string with the highest total forward voltage dominates the control loop. The boost-converter voltage is adjusted so that the driver associated with that string receives just enough voltage as needed for current drive. All other strings with lower total forward voltages will have excess supply voltage, which is then dropped in the associated driver. This feedback mechanism ensures that the linear current-control circuit dissipates the minimum possible power.

The MAX16807 EV kit does not require an external microcontroller to enable the eight LED drivers. The EV kit circuit is configured to enable all LED drivers by tying the MAX16807 DIN (data-in) and LE (latch-enable) pins to a logic-high signal and automatically supplies approximately a 50kHz clock signal. Inverter U2 is configured to generate the clock signal and to implement the PWM dimming function. A 5V (VBIAS) supply is also required to power the MAX16807 constant-current output drivers and the inverter.

Power Supplies

The MAX16807 EV kit requires an 8.8V to 16V power supply connected across VIN and GND PC pads, and a 5V power supply connected across VBIAS and GND PC pads for normal operation. The 8.8V to 16V power supply is used to provide power to the MAX16807 IC (U1) and to the DC-DC step-up power converter. The 5V power supply is used to provide power to the constant-current LED driver of the MAX16807 and to the dual Schmitt trigger inverter (U2). The VBIAS power supply also provides a logic-high voltage signal to the DIN and LE pins.

MAX16807 Evaluation Kit

LED Driver

The MAX16807 feature an 8-channel constant-current LED driver, with each channel capable of sinking up to 55mA of LED current. LED strings can be connected between VLED (J1-1 and J1-2) and the constant-current sink outputs to drive regulated current through each LED string. The current through all eight channels is controlled through resistor R7, which is connected from the SET pin to ground. The current through each string is configured to 50mA and the maximum VLED voltage to 33V. The EV kit can drive LED strings with a total forward voltage of up to 32V.

The MAX16807 4-wire (DIN, CLK, LE, and \overline{OE}) serial interface controls the eight constant-current outputs. The MAX16807 EV kit circuit connects DIN and LE to 5V and uses a clock signal, generated by inverter U2, to clock eight logic 1s into the IC's internal shift register, thus enabling all eight channels. The output enable (\overline{OE}) pin is configured to provide PWM dimming. An inverted PWM signal, generated by the inverter U2, drives the \overline{OE} pin. When the PWM signal is low (LED drivers off) it also influences the feedback with the network formed by R13 and D6. See the *Adaptive LED Voltage Control* section for more details.

Output-Current Setting

The amplitude of the output currents for all eight channels is set by resistor R7. The minimum value for resistor R7 is 324 Ω , which sets the output currents to 55mA. The maximum value of R7 is 4.99k Ω , which sets the output current to 3.6mA. The MAX16807 EV kit sets the output current to 50mA with a 365 Ω R7 resistor. To set a different output current, use the following equation:

$$R7 = \frac{18V}{I_{OUT}}$$

where I_{OUT} is the desired output current.

PWM Dimming

The MAX16807 EV kit features a PWM input PC pad that can be used to control the LED brightness by adjusting the duty cycle of the PWM input signal. Applying a logic-high signal at the PWM input enables the output current and a logic-low signal turns off the output current. The PWM signal is conditioned through inverter U2 before reaching the MAX16807 \overline{OE} pin. Connect a PWM signal with peak amplitude of 3V to 5V and a frequency in the range of 100Hz to 2kHz to the

EV kit PWM input PCB pad. Vary the duty cycle to adjust the LED brightness. The LED brightness increases when the duty cycle increases and vice versa.

SHDN Input

The MAX16807 EV kit features a \overline{SHDN} input PC pad to enable or disable the MAX16807 IC. Connect 5V or VIN to the \overline{SHDN} pad to enable the IC. Connect the \overline{SHDN} pad to ground or leave disconnected to disable the IC. The IC can also be enabled by connecting VIN to test point TP3.

Adaptive LED Voltage Control

To reduce power dissipation in the IC, the MAX16807 EV kit features adaptive voltage control of VLED based on the operating voltage of the LED strings. The constant-current outputs can sink stable currents with channel voltages as low as 0.8V. The voltage at each of the outputs will be the difference between VLED and the total forward voltage of the LED string connected to that output. The MAX16807 EV kit implements a feedback mechanism to sense the voltage at each of the outputs. Using dual zener diodes (D2–D5), the circuit selects the lowest voltage among all the output channels. The PWM boost converter will then adjust VLED until this output channel is 0.8V. All other strings will have sufficient voltage, as their total forward voltages are equal or less. This feedback mechanism ensures that the IC dissipates the minimum possible power. For adaptive control to function efficiently, connect LED strings to all eight channels and use equal number of LEDs of the same V_F rating in each string. Use the following equation to calculate the value of resistor R10 to set the minimum voltage at the outputs:

$$R10 = \frac{(V_{FLED} + V_S - 2.5V)}{2.5V - V_{DZ} - V_S} \times R12$$

where 2.5V is the feedback reference, V_{DZ} is the forward voltage drop (0.65V) of the zener diodes (D2–D5), V_S (0.8V) is the required sink output voltage, and V_{FLED} is the total nominal operating voltage of the LED strings. Select the value of R10 such that R12 is approximately 10k Ω .

Zener diodes D2–D5 also provide output overvoltage protection. If an LED string becomes partially or fully short-circuited, making the sink output voltage rise above 17.5V, the 15V zener diode connected to that output conducts in reverse direction and limits the VLED voltage. Under this condition, the other LED strings might not turn on.

MAX16807 Evaluation Kit

When the outputs are off, the LED drivers are high impedance and the feedback network now combines R13 and D6 to provide a path for the feedback current and to control VLED. Use the following equation to calculate the value of R13 to get the required LED supply voltage during PWM off time:

$$R13 = \frac{R10 \times (2.5V - 0.4V)}{VLEDOFF - 2.5V}$$

where 2.5V is the feedback reference voltage, 0.4V is the total voltage dropped by diode D6, and VLEDOFF is the desired LED supply voltage during PWM off time. VLEDOFF should be set to the worst-case LED string VF voltage, plus additional headroom for the LED drivers that must be greater than 0.8V, as well as a reserve voltage (about +1V). This reserve voltage allows the MAX16807 to provide current for very short PWM dimming pulses. With pulses as low as 2μs, the VLED control loop is not able to react, and the output capacitors provide all the current. For longer PWM dimming pulses, the control loop will react and the supply will operate at the adaptive voltage level.

During an open LED condition, the 33V zener diode (D8) limits the maximum VLED supply voltage to 35.5V. If VLED attempts to increase beyond this level, D8 conducts in reverse direction and pulls the FB pin high, which causes the boost regulator to cut back on the PWM signal and reduce the output voltage.

Boost Converter

The EV kit boost-converter circuit is configured to generate up to 33V of LED voltage (VLED) and operate at a switching frequency of 350kHz in continuous conduction mode (CCM). The MAX16807's current-mode PWM controller drives external MOSFET N1. The MOSFET is turned on at the beginning of every switching cycle and turned off when the current through the inductor (L1) reaches the peak value set by the error-amplifier output voltage. Inductor current is sensed by the MAX16807 CS pin using the voltage across current-sense resistor R9.

The RC filter, consisting of R5 and C8, removes voltage spikes in the current-sense signal produced by the turn-on gate current of MOSFET N1, and the reverse-recovery current of D1. Without filtering, these current spikes can cause the MAX16807 to turn off N1 prematurely. The filter time constant is configured to 120ns.

During normal operating conditions, the feedback loop and compensation network (R1, R10, R11, C6, and C7) control the peak current. The error amplifier compares a scaled-down version of the VLED voltage with the MAX16807 highly accurate 2.5V reference. The error amplifier and compensation network then amplify the

error signal, and the current comparator compares this signal to the sensed current voltage to create a PWM drive output.

Power-Circuit Design

Initially, decide the input supply voltage range, the maximum voltage (VLED) that is required to drive the LED strings, plus 1V (minimum voltage across the constant-current sink = 0.8 + VLED ripple peak), and the output current IOUT (the sum of all the LED string currents).

Calculate maximum duty cycle DMAX using the following equation:

$$D_{MAX} = \frac{VLED + V_D - VIN_{MIN}}{VLED + V_D - VFET}$$

where VD is the forward drop of the rectifier diode D1 (~0.6V), VINMIN is the minimum input supply voltage (in this case, 9V), and VFET is the drain-to-ground voltage of the MOSFET N1 when it is on.

Select the switching frequency (FSW) depending on the space, noise, dynamic response, and efficiency constraints. Select the maximum peak-to-peak ripple on the inductor current (ILPP). For the MAX16807 EV kit, FSW is 350kHz and ILPP is ±30% of the average inductor current. Use the following equations to calculate the maximum average inductor current ILAVG and peak inductor current ILPEAK:

$$I_{LAVG} = \frac{I_{OUT}}{1 - D_{MAX}}$$

Since ILPP is ±30% of the average inductor current ILAVG:

$$I_{LPP} = I_{LAVG} \times 0.3 \times 2$$

$$I_{LPEAK} = I_{LAVG} + \frac{I_{LPP}}{2}$$

Calculate the minimum inductance value LMIN with the inductor current ripple set to the maximum value:

$$L_{MIN} = \frac{(VIN_{MIN} - VFET) \times D_{MAX}}{F_{SW} \times I_{LPP}}$$

Choose an inductor that has a minimum inductance that is greater than this calculated value.

Calculate the current-sense resistor (R8 in parallel with R9) using the equation below:

$$R_{CS} = \frac{0.3 \times 0.75}{I_{LPEAK}}$$

where 0.3V is the maximum current-sense signal voltage. The factor 0.75 is for compensating the reduction of

MAX16807 Evaluation Kit

maximum current-sense voltage due to the addition of slope compensation. Check this factor and adjust after the slope compensation is calculated. Slope compensation is explained in detail in a later section.

The saturation current limit of the selected inductor (I_{LSAT}) should be greater than the value given by the following equation. Selecting an inductor with 10% higher I_{LSAT} rating is a good choice.

$$I_{LSAT} = I_{LPEAK} \times 1.1$$

Calculate the output capacitor C_{OUT} (parallel combination of C1, C2, and C15) using the following equation:

$$C_{OUT} = \frac{D_{MAX} \times I_{OUT}}{V_{LEDPP} \times F_{SW}}$$

where V_{LEDPP} is the peak-to-peak ripple in the LED supply voltage. The value of the calculated output capacitance will be much lower than what is actually necessary for feedback loop compensation. See the *Feedback Compensation* section to calculate the output capacitance based on the compensation requirements.

Calculate the input capacitor C_{IN} (parallel combination of C9, C10, and C11) using the following equation:

$$C_{IN} = \frac{I_{LPP}}{8 \times F_{SW} \times V_{INPP}}$$

where V_{INPP} is the peak-to-peak input ripple voltage. This equation assumes that input capacitors supply most of the input ripple current.

Selection of Power Semiconductors

The switching MOSFET (N1) should have a voltage rating sufficient to withstand the maximum output voltage together with the diode drop of D1, and any possible overshoot due to ringing caused by parasitic inductances and capacitances. Use a MOSFET with voltage rating higher than that calculated by the following equation:

$$V_{DS} = (V_{LED} + V_D) \times 1.3$$

where the factor of 1.3 provides a 30% safety margin.

The continuous drain-current rating of the selected MOSFET, when the case temperature is at +70°C, should be greater than that calculated by the equation below. The MOSFET must be mounted on a board, as per manufacturer specifications, to dissipate the heat.

$$I_{DRMS} = \left(\sqrt{\frac{I_{LAVG}^2}{D_{MAX}}} \right) \times 1.3$$

The MOSFET will dissipate power due to both switching losses, as well as conduction losses. Use the following equation to calculate the conduction losses in the MOSFET:

$$P_{COND} = \frac{I_{LAVG}^2}{D_{MAX}} \times R_{DS(ON)}$$

where $R_{DS(ON)}$ is the on-state drain-source resistance of the MOSFET with an assumed junction temperature of +100°C.

Use the following equation to calculate the switching losses in the MOSFET:

$$P_{SW} = \frac{I_{LAVG} \times V_{LED}^2 \times C_{GD} \times F_{SW}}{2} \times \left(\frac{1}{I_{GON}} + \frac{1}{I_{GOFF}} \right)$$

where I_{GON} and I_{GOFF} are the gate currents of the MOSFET (with V_{GS} equal to the threshold voltage) when it is turned on and turned off, respectively, and C_{GD} is the gate-to-drain MOSFET capacitance. Choose a MOSFET that has a higher power rating than that calculated by the following equation when the MOSFET case temperature is at +70°C:

$$P_{TOT} = P_{COND} + P_{SW}$$

The MAX16807 EV kit uses a Schottky diode as the boost-converter rectifier (D1). A Schottky rectifier diode produces less forward drop and puts the least burden on the MOSFET during reverse recovery. If a diode with considerable reverse-recovery time is used, it should be considered in the MOSFET switching-loss calculation.

The Schottky diode selected should have a voltage rating 20% above the maximum boost-converter output voltage. The current rating of the diode should be greater than I_D in the following equation:

$$I_D = \left(\sqrt{\frac{I_{LAVG}^2}{1 - D_{MAX}}} \right) \times 1.2$$

Slope Compensation

When the boost converter operates in CCM with more than 50% duty cycle, subharmonic oscillations will occur if slope compensation is not implemented. Subharmonic oscillations do not allow the PWM duty cycle to settle to a peak current value set by the voltage feedback loop. The duty cycle oscillates back and forth about the required value (usually at half the switching frequency). Subharmonic oscillations will die out if a sufficient negative slope is added to the inductor peak current. This means that for any peak current set

MAX16807 Evaluation Kit

by the feedback loop, the output pulse will terminate sooner than normally expected. The minimum slope compensation that should be added to stabilize the current loop is half of the worst-case (maximum) falling slope of inductor current.

Adding a ramp, with positive slope in sync with the switching frequency, to the current-sense signal can produce the desired function. The greater the duty cycle, the greater the added voltage, and the greater the difference between the set current and the actual inductor current. In the MAX16807 EV kit, the oscillator ramp signal is buffered using Q1 and added to the current-sense signal with proper scaling to implement the slope compensation. Follow the steps below to calculate the component values for slope compensation.

Calculate the worst-case falling slope of the inductor current using the following equation:

$$I_{LSLOPE} = \frac{(V_{LEDMAX} + V_D - V_{INMIN})}{L_{MIN}}$$

From the inductor current falling slope, find its equivalent voltage slope across the current-sense resistor R_{CS} (R_8 parallel with R_9) using the following equation:

$$V_{SLOPE} = I_{LSLOPE} \times R_{CS}$$

The minimum voltage slope that should be added to the current-sense waveform is half of V_{SLOPE} for ensuring stability up to 100% duty cycle. As the maximum continuous duty cycle used is less than 100%, the minimum required compensation slope becomes:

$$V_{CSLOPE} = \frac{V_{SLOPE} \times (2D_{MAX} - 1) \times 1.1}{D_{MAX}}$$

where the factor 1.1 provides a 10% margin. Resistors R_5 and R_6 determine the attenuation of the buffered voltage slope from the emitter of Q1. The forward drop of signal diode D7, together with the V_{BE} of Q1, almost cancel the 1.1V offset of the ramp waveform. Calculate the approximate slope of the oscillator ramp using the following equation:

$$V_{RSLOPE} = 1.7 \times F_{SW}$$

where 1.7V is the ramp amplitude and F_{SW} is the switching frequency.

Select the value of R_5 so that the input bias current of the current-sense comparators does not add considerable error to the current-sense signal. The value of R_6 for the slope compensation is given by the equation:

$$R_6 = \left(\frac{V_{RSLOPE}}{V_{CSLOPE}} - 1 \right) \times R_5$$

Feedback Compensation

Like any other circuit with feedback, the boost converter that generates the voltage for the LED strings needs to be compensated for stable control of its output voltage. When the boost converter is operated in CCM, there exists a right-half-plane (RHP) zero in the power-circuit transfer function. This zero adds a 20dB/decade gain, together with a 90° phase lag, which is difficult to compensate. The easiest way to avoid this zero is to roll off the loop gain to 0dB, at a frequency less than half of the RHP zero frequency, with a -20dB/decade slope. For a boost converter, the worst-case RHP zero frequency (F_{ZRHP}) is given by the following equation:

$$F_{ZRHP} = \frac{V_{LED}(1 - D_{MAX})^2}{2\pi \times L \times I_O}$$

where D_{MAX} is the maximum duty cycle, L is the inductance of the inductor, and I_O is the output current, which is the sum of all the LED string currents.

The boost converter used in the MAX16807 EV kit is operated in peak current-mode control. There are two feedback loops within a current-mode controlled converter: an inner loop that controls the inductor current, and an outer loop that controls the output voltage. The amplified voltage error produced by the outer voltage loop is the input to the inner current loop that controls the peak inductor current.

The internal current loop converts the double-pole/second-order system, formed by the inductor and the output capacitor C_{OUT} , to a first-order system having a single pole consisting of the output filter capacitor and the output load. As the output load is a constant current (very high Thevenin impedance), this pole is located near the origin (0Hz). The phase lag created by the output pole for any frequency will be 90°. However, as the power circuit DC gain is limited by other factors, the gain starts falling at -20dB/decade from a non-zero frequency before which the power circuit gain will be stable.

Total gain of the feedback loop at DC is given by the following equation:

$$G_{TOT} = G_P \times G_{EA} \times G_{FB}$$

where G_P is the power-circuit DC gain and G_{EA} is the error-amplifier open-loop DC gain, typically 100dB. G_{FB} is the gain of the feedback network for adaptive control of the VLED, which is seen from VLED to the error-amplifier input (FB pin). The adaptive control senses

MAX16807 Evaluation Kit

the voltages at the eight constant-current sink outputs and adjusts the feedback to control these voltages to a minimum value. As the LEDs carry constant current, the voltage across the LEDs does not change with variations in VLED. Any change in VLED directly reflects to the constant-current sink outputs and to the error-amplifier input, making G_{FB} equal to unity.

The DC gain of the power circuit is expressed as the change in the output voltage (ΔV_{LED}), with respect to the change in error-amplifier output voltage (ΔE_{AOUT}). As the boost converter in the MAX16807 EV kit drives a constant-current load, the power circuit DC gain is calculated by the following equation:

$$G_P = \frac{\Delta V_{LED}}{\Delta E_{AOUT}}$$

Calculate the power circuit DC gain using the following equation:

$$G_P = \frac{1}{\left(\frac{V_{IN}^2}{2 \times L \times F_{SW} \times V_{LED}^2} + \frac{I_O}{V_{IN}} \right) \times R_{CS} \times 3}$$

where R_{CS} is the current-sense resistor, F_{SW} is the switching frequency, and the factor 3 is to account for the attenuation of error-amp output before it is fed to the current-sense comparator.

The power-circuit gain will be the lowest at the minimum input supply voltage and highest at the maximum input supply voltage. Any input supply voltage between 9V and 16V can be used for the power-circuit gain calculation, since the final compensation values obtained will be the same.

Calculate the frequency F_{P2} , at which the power-circuit gain starts falling, at -20dB/decade using the following equation:

$$F_{P2} = \frac{(1-D_{MAX})}{2\pi \times C_{OUT} \times 3 \times R_{CS} \times G_P}$$

where C_{OUT} is the output filter capacitor, which is the parallel combination of C1, C2, and C15. Adjust the output capacitance such that the product of F_{P2} and G_P is below $F_{ZRHP} / 6$. The value of output capacitance obtained this way will be much greater than the value obtained using the maximum output voltage ripple specification.

The compensation strategy is as follows. The gain-frequency response of the feedback loop should cross 0dB at or below half of the RHP zero frequency, with a slope of -20dB/decade for the feedback to be stable and have sufficient phase margin. The compensation network from the COMP pin to the FB pin of MAX16807 (formed by R1, C6, C7, and R11) offers one dominant pole (P1), a zero (Z1), and a high-frequency pole (P3). There are two very-low-frequency poles and a zero in the loop before the crossover frequency. The function of the zero (Z1) is to compensate for the output pole and reduce the slope of the loop gain from -40dB/decade to -20dB/decade, and also to reduce the phase lag by 90°.

Choose the crossover frequency to be half of the worst-case RHP zero frequency:

$$F_C = \frac{F_{ZRHP}}{2}$$

Place the zero (Z1) at one-third of the crossover frequency so that the phase margin starts improving from a sufficiently lower frequency:

$$F_{Z1} = \frac{F_C}{3}$$

Use the following equation to calculate the dominant pole location so that the loop gain crosses 0dB at F_C :

$$F_{P1} = \frac{F_{ZRHP} \times F_{Z1}}{2 \times G_{TOT} \times F_{P2}}$$

As the open-loop gain of the error amplifier can have variations, the dominant pole location can also vary from device to device. In the MAX16807 EV kit, the dominant pole location is decided by the error-amplifier gain and so the combined effect is a constant gain-bandwidth product.

Select the value of R11 such that the input bias current of the error amplifier does not cause considerable drop across it. The effective AC impedance seen from the FB pin is the sum of R11 and R12. It is preferable to keep R12 much less, compared to R11, to have better control on the AC impedance. Find C6 using the following equation:

$$C6 = \frac{1}{2\pi \times G_{EA} \times (R11 + R12) \times F_{P1}}$$

MAX16807 Evaluation Kit

The location of the zero (Z1), decided by R1 and C6, is given by the following equation:

$$F_{Z1} = \frac{1}{2\pi \times R1 \times C6}$$

Place the high-frequency pole (P3), formed by C6, C7, and R1, at half the switching frequency to provide further attenuation to any high-frequency signal propagating through the system. The location of the high-frequency pole (F_{P3}) is given by the following equation and should be used to calculate the value of C7:

$$F_{P3} = \frac{1}{2\pi \times R1 \times \left(\frac{1}{C6} + \frac{1}{C7}\right)^{-1}}$$

The MAX16807 EV kit uses electrolytic capacitors at the output for filtering, so the zero produced by the ESR of the capacitors can be low enough to be within or near the crossover frequency. This zero should be compensated using an additional pole (P4) placed at the ESR zero location. The ESR zero frequency is calculated using the following equation:

$$F_{ZESR} = \frac{1}{2\pi \times ESR \times C_{OUT}}$$

Use the following equation to calculate the value of C25, to place the pole P4 at the ESR zero frequency:

$$C25 = \frac{1}{2\pi \times F_{ZESR} \times R12}$$

If ceramic capacitors are used at the output for filtering, the frequency of zero produced by the ESR and the capacitance will be much above the crossover frequency (0dB gain frequency) of the feedback loop, and hence, need not be considered in the compensation design.

Layout Considerations

LED driver circuits based on the MAX16807 device use a high-frequency switching converter to generate the voltage for LED strings. Proper care must be taken while laying out the circuit to ensure proper operation. The switching-converter part of the circuit has nodes with very fast voltage changes—producing high-frequency electric fields and PCB traces with fast current changes—resulting in high-frequency magnetic fields. As the circuit converts power, the amplitude of these

fields will be high and can easily couple to sensitive parts of the circuit, creating undesirable effects. Follow the guidelines below to reduce noise as much as possible:

- 1) Connect the bypass capacitors from REF and VCC as close as possible to the device and connect the capacitor grounds to the analog ground plane using vias close to the capacitor terminals. Connect the AGND pin of the device to the analog ground plane using a via close to the pin. Lay the analog ground plane on the inner layer, preferably next to the top layer. Use the analog ground plane to cover the entire area under critical signal components for the power converter.
- 2) Keep the oscillator timing capacitor and resistor very close to the RTCT pin and make the connection as short as possible. Connect the ground of the timing capacitor to the analog ground plane using a via close to the capacitor terminal. Make sure that no switching node is present near the RTCT node and keep the area of the copper connected to the pin small. Keep the REF connection to the timing resistor short and away from any switching node.
- 3) Have a power ground plane for the switching-converter power circuit under the power components (input filter capacitor, output filter capacitor, inductor, MOSFET, rectifier diode, and current-sense resistor). Connect all the ground connections to the power ground plane using vias close to the terminals.
- 4) There are two loops in the power circuit that carry high-frequency switching currents. One loop is when the MOSFET is on—from the input filter capacitor positive terminal, through the inductor, the MOSFET, and the current-sense resistor, to the input capacitor negative terminal. The other loop is when the MOSFET is off—from the input capacitor positive terminal, through the inductor, the rectifier diode, output filter capacitor, to the input capacitor negative terminal. Analyze these two loops and make the loop areas as small as possible. Wherever possible, have a return path on the power ground plane for the switching currents on the top-layer copper traces, or through power components. This will reduce the loop area considerably and provide a low-inductance path for the switching currents. Reducing the loop area also reduces radiation during switching.

MAX16807 Evaluation Kit

- 5) The gate drive current of the MOSFET is another high-frequency switching current to consider. There are two major loops: one during the MOSFET turn-on edge and the second during the turn-off edge. The MOSFET turn-on loop is from the VCC bypass capacitor positive terminal, through the MOSFET driver in the device, the gate drive resistor, the MOSFET gate to source (CGS and CGD), and the current-sense resistor to the VCC bypass capacitor negative terminal. There is no direct path for the current from the current-sense resistor to return to the VCC bypass capacitor through the ground plane, as the VCC bypass capacitor is connected to the analog ground plane and the current-sense resistor is connected to the power ground plane. The best solution is to connect the analog ground plane to the power ground plane directly under the MOSFET gate drive trace. This will ensure that the turn-off current also has a return path on the ground plane.
- 6) The drain node of the MOSFET is a switching node. Keep this node area small to reduce radiation and capacitive coupling to other sensitive parts of the circuit. However, the trace should be wide enough to carry the large switching currents.
- 7) Keep the node area and trace length on the FB pin small to reduce any noise pick up.
- 8) Connect the power ground plane for the constant-current LED driver part of the circuit to the boost converter output filter capacitor negative terminal.

Power Dissipation

The MAX16807 dissipates power during normal operating conditions. The heat transferred to the exposed pad from the die should be properly dissipated to the board to prevent the device from entering into thermal shutdown. The exposed pad land area on the top layer should be of the same size as that of the exposed pad. Thermal vias are used to carry the heat from the exposed pad to other layers of the board and spread it across the board area through copper planes. Thermal vias should have a maximum 0.4mm hole size and should be placed at a distance of 1mm from center to center. For a four-layer board, these vias should be connected to the bottom ground plane and to one internal ground plane. Do not use thermal relief for the thermal vias; instead, use solid copper to get the minimum thermal resistance.

Use the following equation to calculate the total power dissipated in the MAX16807 device during normal operation:

$$P_D = \sum_{N=0-7} V_{S_N} \times I_{OUT} + I_B \times V_{IN}$$

where V_S is the operating voltage of each of the LED driver outputs with respect to GND pins, I_B is the input bias current of the MAX16807 including the average of MOSFET drive current, and V_{IN} is the input supply voltage. To dissipate 1W of power, the exposed pad of the device should be connected to a minimum of 2 square inches of copper ground plane with 1oz copper thickness.

MAX16807 Evaluation Kit

Evaluates: MAX16807

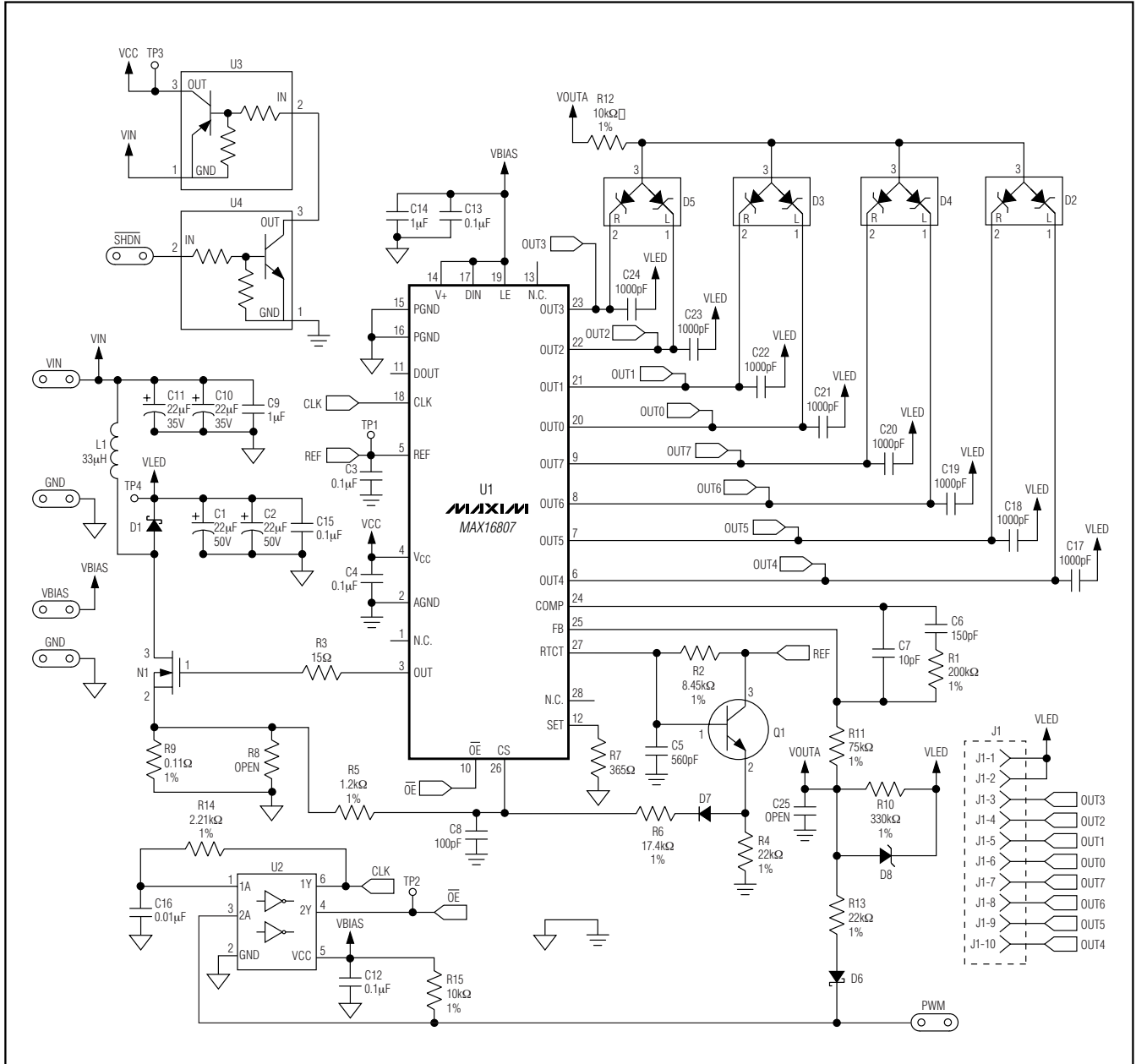

Figure 1. MAX16807 EV Kit Schematic

MAX16807 Evaluation Kit

Evaluates: **MAX16807**

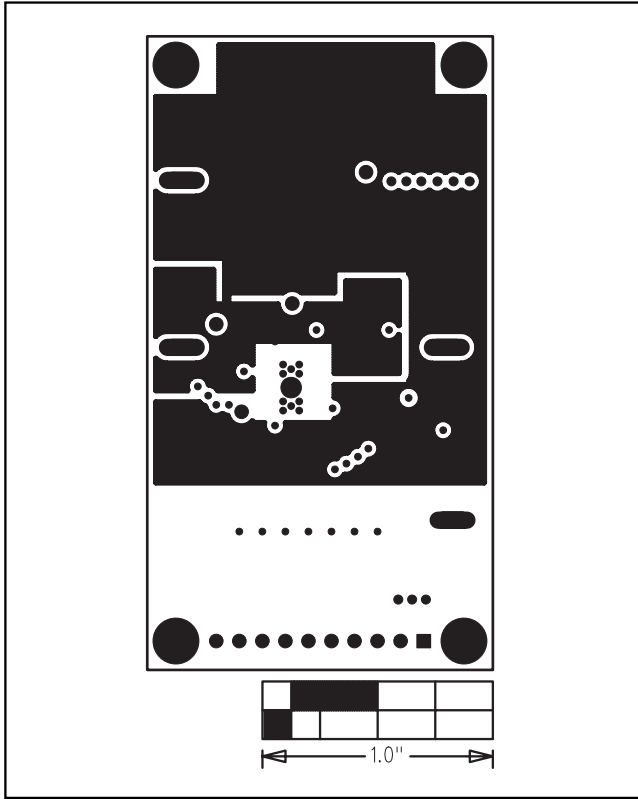

Figure 4. MAX16807 EV Kit PCB Layout—Ground Layer 2

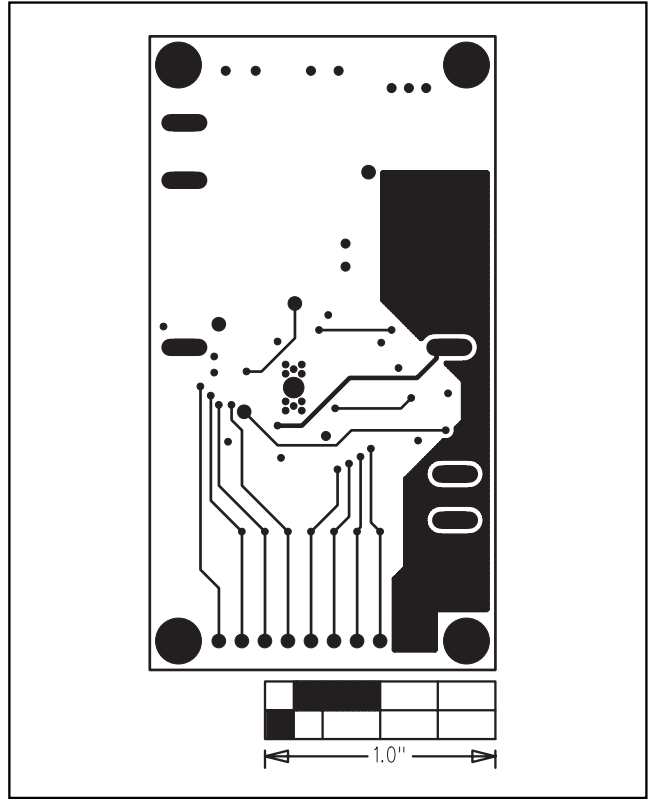

Figure 5. MAX16807 EV Kit PCB Layout—Ground Layer 3

MAX16807 Evaluation Kit

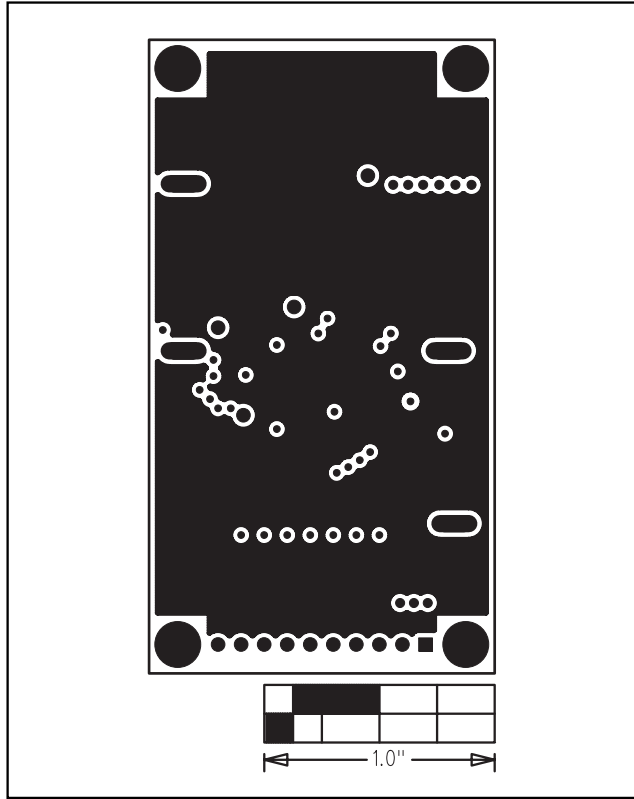

Figure 6. MAX16807 EV Kit PCB Layout—Solder Side

Maxim cannot assume responsibility for use of any circuitry other than circuitry entirely embodied in a Maxim product. No circuit patent licenses are implied. Maxim reserves the right to change the circuitry and specifications without notice at any time.

14 **Maxim Integrated Products, 120 San Gabriel Drive, Sunnyvale, CA 94086 408-737-7600**