



Chipsmall Limited consists of a professional team with an average of over 10 year of expertise in the distribution of electronic components. Based in Hongkong, we have already established firm and mutual-benefit business relationships with customers from,Europe,America and south Asia,supplying obsolete and hard-to-find components to meet their specific needs.

With the principle of "Quality Parts,Customers Priority,Honest Operation,and Considerate Service",our business mainly focus on the distribution of electronic components. Line cards we deal with include Microchip,ALPS,ROHM,Xilinx,Pulse,ON,Everlight and Freescale. Main products comprise IC,Modules,Potentiometer,IC Socket,Relay,Connector.Our parts cover such applications as commercial,industrial, and automotives areas.

We are looking forward to setting up business relationship with you and hope to provide you with the best service and solution. Let us make a better world for our industry!



Contact us

Tel: +86-755-8981 8866 Fax: +86-755-8427 6832

Email & Skype: info@chipsmall.com Web: www.chipsmall.com

Address: A1208, Overseas Decoration Building, #122 Zhenhua RD., Futian, Shenzhen, China





Internal-Switch Boost Regulator with Integrated Scan Driver, VCOM Calibrator, and Op Amp for TFT LCDs

MAX17100

General Description

The MAX17100 includes a high-voltage step-up regulator, three high-performance operational amplifiers, two linear regulators, two high-voltage switch control blocks for gate-driver supply modulation, a digital VCOM calibrator, and six independent scan drivers.

The DC-DC converter is a 1.2MHz current-mode step-up regulator with a built-in power MOSFET and provides the regulated supply voltage for the panel source driver ICs. The built-in power MOSFET allows output voltages to be as high as 18V from inputs of 2.5V to 6V. A built-in 7-bit digital soft-start function limits inrush currents during startup. The step-up regulator provides fast transient response to pulsed loads while producing efficiencies over 87%.

Three operational amplifiers, typically used as the gamma correction divider string, are configured as unity-gain buffers and feature high output short-circuit current (200mA), fast slew rate (45V/μs), and wide bandwidth (20MHz). Their rail-to-rail inputs and outputs maximize application flexibility.

Two linear regulators provide regulated gate-on and gate-off supplies for TFT panel. The two high-voltage switch control blocks modulate the shape of the gate-on supply with adjustable startup delay.

One operational amplifier is designed to drive the LCD backplane (VCOM). It features high short-circuit current of 200mA. The programmable VCOM calibrator adjusts the VCOM output-voltage level through serial interface by sinking a programmable current from the VCOM resistor-divider. The calibrator includes nonvolatile memory cells that store the desired VCOM voltage level.

The six independent high-voltage level-shifting scan drivers are designed to drive the TFT panel gate lines. The outputs swing from +35V (maximum) to -15V (minimum) and can swiftly drive capacitive loads.

The MAX17100 is available in a lead-free, 48-pin, thin QFN package with 0.4mm lead spacing. The package is a 6mm x 6mm square with a maximum thickness of 0.8mm for ultra-thin LCD panel design.

Applications

LCD Monitors
LCD TVs

Features

- ◆ 2.5V to 6V Input Supply Range
- ◆ 1.2MHz Current-Mode Step-Up Converter
 - Fast Transient Response to Pulsed Load
 - High-Accuracy Output Voltage (1%)
 - Built-In 20V, 3A, 0.16Ω n-Channel Power MOSFET
 - Cycle-by-Cycle Current Limit
 - High Efficiency (87%)
- ◆ Three High-Performance Operational Amplifiers
 - 200mA Output Short-Circuit Current
 - 45V/μs Slew Rate
 - 20MHz, -3dB Bandwidth
 - Rail-to-Rail Inputs and Outputs
- ◆ Linear Regulator for Gate-On and Gate-Off Supply
- ◆ Two Logic-Controlled High-Voltage Switches with Adjustable Delay
- ◆ Programmable VCOM Calibrator
 - 7-Bit Adjustable Current-Sink Output
 - Serial Interface
 - Nonvolatile Setting Memory
- ◆ Six Independent Level-Shifting Scan Drivers
- ◆ Built-In Sequencing
- ◆ Soft-Start and Timer-Delayed Fault Latch for All Regulator Outputs
- ◆ Thermal-Overload Protection
- ◆ Gate Driver for External Input-Side Series MOSFET

Ordering Information

PART	TEMP RANGE	PIN-PACKAGE
MAX17100ETM+	-40°C to +85°C	48 Thin QFN-EP*

+Denotes a lead(Pb)-free/RoHS-compliant package.

*EP = Exposed pad.

Pin Configuration and Minimal Operating Circuit appear at end of data sheet.

Internal-Switch Boost Regulator with Integrated Scan Driver, VCOM Calibrator, and Op Amp for TFT LCDs

ABSOLUTE MAXIMUM RATINGS

IN, YV1C_, GATE to AGND	-0.3V to +7.5V
SCL, SDA, WR, RST, RSET, ST_, CK_, CKB_ to AGND	-0.3V to +7.5V
TGS, REF, COMP, FB, FBN, FBP, to AGND	-0.3V to (V _{IN} + 0.3V)
PGND, OGND to AGND	-0.3V to +0.3V
LX to PGND	-0.3V to +20V
SUP to OGND	-0.3V to +20V
DRVN to AGND	(V _{IN} - 30V) to (V _{IN} + 0.3V)
DRV_P to AGND	-0.3V to +40V
GHON to AGND	-0.3V to +40V
GOFF to AGND	-20V to +0.3V
GHON to GOFF	-0.3V to +50V
GHD_ to AGND	-0.3V to (V _{GHON} + 0.3V)

STH_, CKH_, CKBH_	(-0.3V + V _{GOFF}) to (V _{GHON} + 0.3V)
POS_, OUT_, COMFB, COMADJ, VCOM to OGND	-0.3V to (V _{SUP} + 0.3V)
COMADJ to COMFB	-6V to +6V
OUT_ Maximum Continuous Output Current	±75mA
GHON, GOFF RMS Current Rating	130mA
LX, PGND RMS Current Rating	2.4A
Continuous Power Dissipation (T _A = +70°C) 48-Pin TQFN (derate 27mW/°C above +70°C)	2150mW
Operating Temperature Range	-40°C to +85°C
Junction Temperature	+150°C
Storage Temperature Range	-65°C to +160°C
Lead Temperature (soldering, 10s)	+300°C
Soldering Temperature (reflow)	+260°C

Stresses beyond those listed under "Absolute Maximum Ratings" may cause permanent damage to the device. These are stress ratings only, and functional operation of the device at these or any other conditions beyond those indicated in the operational sections of the specifications is not implied. Exposure to absolute maximum rating conditions for extended periods may affect device reliability.

ELECTRICAL CHARACTERISTICS

(V_{IN} = +3V, Circuit of Figure 2, V_{MAIN} = V_{SUP} = +14V, T_A = 0°C to +85°C, unless otherwise noted. Typical values are at T_A = +25°C.)

PARAMETER	CONDITIONS	MIN	TYP	MAX	UNITS
IN Input Supply Range	(Note 1)	2.5		6	V
IN Undervoltage Lockout Threshold	V _{IN} rising, hysteresis = 140mV	2.05	2.25	2.45	V
IN Quiescent Current	V _{FB} = V _{FBP} = 1.3V, V _{FBN} = 0V, LX not switching		1	3	mA
	V _{FB} = 1.2V, V _{FBP} = 1.4V, V _{FBN} = 0V, LX switching		3	5	
Duration to Trigger Fault Condition	FB or FBP below threshold or FBN above threshold; V _{FB} = 1.14V, V _{FBP} = 1V, V _{FBN} = 420mV		218		ms
Thermal Shutdown	Temperature rising		160		°C
	Hysteresis		15		
REFERENCE					
REF Output Voltage	No external load	1.238	1.250	1.262	V
REF Load Regulation	0V < I _{LOAD} < 50µA			10	mV
REF Undervoltage Lockout Threshold	Rising edge, hysteresis = 120mV		1.0	1.15	V
STEP-UP REGULATOR					
Output-Voltage Range		V _S		18	V
Frequency		1000	1200	1400	kHz
Oscillator Maximum Duty Cycle		90	91.5	93	%
FB Regulation Voltage	No load, T _A = 0°C to +85°C	1.221	1.233	1.245	V
FB Fault Trip Level	Falling edge	1.10	1.14	1.17	V
FB Load Regulation	0V < I _{LOAD} < 500mA, transient only		-0.2		%
FB Line Regulation	V _{IN} = 2.5V to 6V		0.1	0.4	%/V
FB Input Bias Current	V _{FB} = 1.233V, T _A = +25°C		100	200	nA
FB Transconductance	ΔI = ±2.5µA, FB = COMP	80	190	300	µS
FB Voltage Gain	FB to COMP		2500		V/V
LX Current Limit	V _{FB} = 1.2V, duty cycle = 75%	2.5	3	3.5	A

Internal-Switch Boost Regulator with Integrated Scan Driver, VCOM Calibrator, and Op Amp for TFT LCDs

ELECTRICAL CHARACTERISTICS (continued)

($V_{IN} = +3V$, Circuit of Figure 2, $V_{MAIN} = V_{SUP} = +14V$, $T_A = 0^{\circ}C$ to $+85^{\circ}C$, unless otherwise noted. Typical values are at $T_A = +25^{\circ}C$.)

PARAMETER	CONDITIONS	MIN	TYP	MAX	UNITS
LX On-Resistance	$I_{LX} = 200mA$		0.12	0.25	Ω
LX Bias Current	$V_{LX} = 19V$, $T_A = +25^{\circ}C$		10	20	μA
Current-Sense Transresistance		0.10	0.20	0.30	V/A
GATE-ON LINEAR REGULATOR CONTROLLER					
FBP Fault Trip Level	V_{FBP} falling	0.96	1.00	1.04	V
FBP Regulation Voltage	$I_{DRVP} = 100\mu A$	1.231	1.250	1.269	V
FBP Line Regulation Error	$V_{IN} = 2.5V$ to $6V$, $I_{DRVP} = 100\mu A$	-10		+10	mV
FBP Input Bias Current	$V_{FBP} = 1.25V$, $T_A = +25^{\circ}C$	-50		+50	nA
FBP Effective Load Regulation Error (Transconductance)	$V_{DRVP} = 10V$, $I_{DRVP} = 50\mu A$ to $1mA$		-1	-1.5	%
DRVP Sink Current	$V_{FBP} = 1.1V$, $V_{DRVP} = 10V$	1	5		mA
DRVP Off-Leakage Current	$V_{FBP} = 1.4V$, $V_{DRVP} = 34V$, $T_A = +25^{\circ}C$		0.01	10	μA
Soft-Start Period			14		ms
Soft-Start Step Size			$V_{REF}/128$		V
GATE-OFF LINEAR REGULATOR CONTROLLER					
FBN Fault Trip Level	V_{FBN} rising	370	420	470	mV
FBN Regulation Voltage	$I_{DRVN} = 100\mu A$, $V_{REF} - V_{FBN}$	0.985	1	1.015	V
FBN Line Regulation Error	$V_{IN} = 2.5V$ to $6V$, $I_{DRVN} = 100\mu A$	-5		+5	mV
FBN Input Bias Current	$V_{FBN} = 0.25V$, $T_A = +25^{\circ}C$	-50		+50	nA
FBN Effective Load Regulation Error (Transconductance)	$V_{DRVN} = -10V$, $I_{DRVN} = 50\mu A$ to $1mA$		11	25	mV
DRVN Source Current	$V_{FBN} = 300mV$, $V_{DRVN} = -10V$	1	5		mA
DRVN Off-Leakage Current	$V_{FBN} = 0V$, $V_{DRVN} = -25V$, $T_A = +25^{\circ}C$		0.01	10	μA
Soft-Start Period			14		ms
Soft-Start Step Size			$(V_{REF} - V_{FBN})/128$		V
POSITIVE GATE-DRIVER TIMING AND CONTROL SWITCHES					
TGS Capacitor Charge Current	During startup, $V_{TGS} = 1V$	4	5	6	μA
TGS Turn-On Threshold		1.19	1.25	1.31	V
TGS Discharge Switch On-Resistance	During UVLO, $V_{IN} = 2V$		14		Ω
YV1C_ Input Low Voltage				0.6	V
YV1C_ Input High Voltage	$V_{IN} < 4.5V$	1.75			V
	$V_{IN} > 4.5V$	2.1			
YV1C_ Input Leakage Current	$YV1C_ = AGND$ or IN , $T_A = +25^{\circ}C$	-1		+1	μA
YV1C_-to-GHON Propagation Delay	Rising		100		ns
	Falling		300		
GHON Input-Voltage Range				35	V

Internal-Switch Boost Regulator with Integrated Scan Driver, VCOM Calibrator, and Op Amp for TFT LCDs

ELECTRICAL CHARACTERISTICS (continued)

($V_{IN} = +3V$, Circuit of Figure 2, $V_{MAIN} = V_{SUP} = +14V$, $T_A = 0^{\circ}C$ to $+85^{\circ}C$, unless otherwise noted. Typical values are at $T_A = +25^{\circ}C$.)

PARAMETER	CONDITIONS	MIN	TYP	MAX	UNITS
GHON Input Current	YV1C_ is high, CK_-, CKB_-, ST_ are low, ($V_{GHON} = 32.5V$, $V_{GOFF} = -12.5V$)		820	1550	μA
GHON to GHC_ Switch On-Resistance	$V_{TGS} = 1.5V$, YV1C_ = IN		6	12	Ω
GHD_ to GHC_ Switch On-Resistance	$V_{TGS} = 1.5V$, YV1C_ = AGND		30	60	Ω
INPUT SERIES SWITCH CONTROL					
GATE Output Sink Current	GATE = IN	45	50	55	μA
GATE Done Voltage Threshold	$V_{IN} - V_{GATE}$		1.5	2.2	V
GATE-On Voltage	$V_{IN} = 5V$			0.5	V
BUFFER AMPLIFIERS					
SUP Supply Range		6		18	V
SUP Overvoltage Fault Threshold		18.1	19.0	19.9	V
SUP Supply Current	All op amps are no load with $V_{POS} = V_{SUP}/2$		13	16	mA
Input Offset Voltage	$V_{POS_} = V_{SUP}/2$, $T_A = +25^{\circ}C$	-8	+4	+16	mV
Input Bias Current	$V_{POS_} = V_{SUP}/2$, $T_A = +25^{\circ}C$	-50		+50	nA
Input Common-Mode Voltage Range		0		V_{SUP}	V
Output-Voltage Swing High	$I_{OUT_} = 5mA$	$V_{SUP} - 100$			mV
Output-Voltage Swing Low	$I_{OUT_} = -5mA$			100	mV
Slew Rate			100		V/ μs
-3dB Bandwidth	$R_L = 10k\Omega$, $C_L = 10pF$, buffer configuration		20		MHz
Short-Circuit Current	Source: $V_{POS_} = V_{SUP} - 3V$, $V_{OUT_} = V_{SUP} - 4V$	115	200		mA
	Sink: $V_{POS_} = 3V$, $V_{OUT_} = 4V$	115	200		
Power-Supply Rejection Ratio (Note 4)	DC, $10V \leq V_{SUP} \leq 18V$, $V_{POS_} = 7V$		100		dB
VCOM OPERATIONAL AMPLIFIER					
Input Bias Current	$V_{COMFB} = V_{COMADJ} = V_{SUP}/2$, $T_A = +25^{\circ}C$	-50		+50	nA
SUP Supply Current	Buffer configuration, $V_{COMADJ} = V_{SUP}/2$, no load		3	4	mA
Input Offset Voltage		-8	+4	+16	mV
Output-Voltage Swing High	$I_{VCOM} = 75mA$	$V_{SUP} - 1.5$	$V_{SUP} - 0.6$		V
Output-Voltage Swing Low	$I_{VCOM} = -75mA$		0.4	1.5	V
Slew Rate			100		V/ μs
-3dB Bandwidth	$R_L = 10k\Omega$, $C_L = 10pF$, buffer configuration		20		MHz
Short-Circuit Current	Buffer configuration, Source: $V_{COMADJ} = V_{SUP} - 3V$, $V_{VCOM} = V_{SUP} - 4V$	115	200		mA
	Buffer configuration, Sink: $V_{COMADJ} = 3V$, $V_{VCOM} = 4V$				

Internal-Switch Boost Regulator with Integrated Scan Driver, VCOM Calibrator, and Op Amp for TFT LCDs

ELECTRICAL CHARACTERISTICS (continued)

($V_{IN} = +3V$, Circuit of Figure 2, $V_{MAIN} = V_{SUP} = +14V$, $T_A = 0^{\circ}C$ to $+85^{\circ}C$, unless otherwise noted. Typical values are at $T_A = +25^{\circ}C$.)

PARAMETER	CONDITIONS	MIN	TYP	MAX	UNITS
PROGRAMMABLE VCOM CALIBRATOR					
SUP Input Range	For MEMORY writing	8		18	V
RSET Voltage Resolution		7			Bits
RSET Differential Nonlinearity	Monotonic overtemperature	-1		+1	LSB
RSET Zero-Scale Error		-1	+1	+2	LSB
RSET Full-Scale Error		-4		+4	LSB
RSET Current	$V_{COMADJ} = 4V$, V_{COM} DAC code = 7FH			120	μA
RSET External Resistance (Note 2)	To AGND, $V_{SUP} = 18V$	8.5		170	$k\Omega$
	To AGND, $V_{SUP} = 6V$	3.3		50	
V_{RSET}/V_{SUP} Voltage Ratio	DAC full scale		0.05		V/V
COMADJ Settling Time	To ± 0.5 LSB error band		20		μs
Memory Write Cycles		30			Cycles
\overline{WR} Input Low Voltage				1	V
\overline{WR} Input High Voltage		2			V
\overline{WR} Leakage Current	$\overline{WR} = AGND$ or IN , $T_A = +25^{\circ}C$	-1		+1	μA
MTP Write Time		160	218	250	ms
SERIAL INTERFACE					
Logic-Input Low Voltage	SDA, SCL			$0.3 \times V_{IN}$	V
Logic-Input High Voltage	SDA, SCL	$0.7 \times V_{IN}$			V
Logic-Output Low Sink Current (SDA)	SDA sink 3mA	0		0.4	V
Logic-Input Current	SDA, SCL, $T_A = +25^{\circ}C$	-1		+1	μA
SDA and SCL Input Capacitance	SDA, SCL		5		pF
SCL Frequency (f_{CLK})		DC		400	kHz
SCL High Time (t_{CLH})		600			ns
SCL Low Time (t_{CLL})		1300			ns
SDA and SCL Rise Time (t_R)	$C_b =$ total capacitance of bus line in pF	20 + $0.1 \times C_b$		300	ns
SDA and SCL Fall Time (t_F)	$C_b =$ total capacitance of bus line in pF	20 + $0.1 \times C_b$		300	ns
START Condition Hold Time (t_{HDSTT})	10% of SDA to 90% of SCL	600			ns
START Condition Setup Time (t_{SUSTT})		600			ns
Data Input Hold Time (t_{HDDAT})		200		900	ns
Data Input Setup Time (t_{SUDAT})		100			ns
STOP Condition Setup Time (t_{SUST})		600			ns
Bus Free Time (t_{BF})		1300			ns
Input Filter Spike Suppression	SDA, SCL, not tested			50	ns

Internal-Switch Boost Regulator with Integrated Scan Driver, VCOM Calibrator, and Op Amp for TFT LCDs

ELECTRICAL CHARACTERISTICS (continued)

($V_{IN} = +3V$, Circuit of Figure 2, $V_{MAIN} = V_{SUP} = +14V$, $T_A = 0^{\circ}C$ to $+85^{\circ}C$, unless otherwise noted. Typical values are at $T_A = +25^{\circ}C$.)

PARAMETER	CONDITIONS	MIN	TYP	MAX	UNITS
RESET FUNCTION					
RST Delay Threshold Voltage	$V_{REF} = 1.25V$	1.225	1.250	1.275	V
RST Sink Current	$V_{RST} = 0.4V$	10	40		mA
LEVEL SHIFTERS					
GHON to GOFF Voltage Range	$V_{GHON} - V_{GOFF}$			45	V
GHON Input-Voltage Range				35	V
GOFF Input-Voltage Range		-15			V
GHON Supply Current	YV1C_ is low, CK_, CKB_, ST_ are low, ($V_{GHON} = 32.5V$, $V_{GOFF} = -12.5V$)		450	830	μA
GOFF Supply Current	YV1C_ is high, CK_, CKB_, ST_ are low, ($V_{GHON} = 32.5V$, $V_{GOFF} = -12.5V$)		150	310	μA
	YV1C_ is high, CK_, CKB_, ST_ are high, ($V_{GHON} = 32.5V$, $V_{GOFF} = -12.5V$)		60	150	
ST_,CK_,CKB_ Input Current	$T_A = +25^{\circ}C$	-1		+1	μA
CKH_,CKBH_,STH_ Output-Voltage Low	$I_{OUT} = 10mA$		$V_{GOFF} + 0.3$	$V_{GOFF} + 1.0$	V
CKH_,CKBH_,STH_ Output-Voltage High	$I_{OUT} = 10mA$	$V_{GHON} - 1.0$	$V_{GHON} - 0.3$		V
ST_,CK_,CKB_ Input High Level	$V_{IN} < 4.5V$	1.6			V
	$V_{IN} > 4.5V$	2.0			
ST_,CK_,CKB_ Input Low Level				0.6	V
CKH_,CKBH_,STH_ Rise Time (Note 4)	$C_L = 5nF$, $R_L = 50\Omega$		0.5		μs
CKH_,CKBH_,STH_ Fall Time (Note 4)	$C_L = 5nF$, $R_L = 50\Omega$		0.5		μs
CKH_,CKBH_ and STH_ Propagation Delay (Note 4)	$C_L = 5nF$, $R_L = 50\Omega$ rising edge, falling edge		60		ns

Internal-Switch Boost Regulator with Integrated Scan Driver, VCOM Calibrator, and Op Amp for TFT LCDs

ELECTRICAL CHARACTERISTICS

($V_{IN} = +3V$, Circuit of Figure 2, $V_{MAIN} = V_{SUP} = +14V$, $T_A = -40^{\circ}C$ to $+85^{\circ}C$, unless otherwise noted.)(Note 3)

PARAMETER	CONDITIONS	MIN	TYP	MAX	UNITS
IN Input Supply Range	(Note 1)	2.5		6	V
IN Undervoltage Lockout Threshold	V_{IN} rising, hysteresis = 140mV	2.05		2.45	V
IN Quiescent Current	$V_{FB} = V_{FBP} = 1.3V$, $V_{FBN} = 0V$, LX not switching			3	mA
	$V_{FB} = 1.2V$, $V_{FBP} = 1.4V$, $V_{FBN} = 0V$, LX switching			5	
REFERENCE					
REF Output Voltage	No external load	1.238		1.262	V
REF Load Regulation	$0V < I_{LOAD} < 50\mu A$			10	mV
REF Undervoltage Lockout Threshold	Rising edge, hysteresis = 120mV		1.0	1.15	V
STEP-UP REGULATOR					
Output-Voltage Range		V_S		18	V
Frequency		1000		1400	kHz
Oscillator Maximum Duty Cycle		90		94	%
FB Regulation Voltage	No load	1.221		1.245	V
FB Line Regulation	$V_{IN} = 2.5V$ to $6V$			0.4	%/V
FB Transconductance	$I = \pm 2.5\mu A$, FB = COMP	75		280	μS
LX Current Limit	$V_{FB} = 1.2V$, duty cycle = 75%	-10		+10	mV
FBP Effective Load Regulation Error (Transconductance)	$V_{DRVP} = 10V$, $I_{DRVP} = 50\mu A$ to $1mA$			-1.5	%
DRVP Sink Current	$V_{FBP} = 1.1V$, $V_{DRVP} = 10V$	1			mA
GATE-OFF LINEAR REGULATOR CONTROLLER					
FBN Regulation Voltage	$I_{DRVN} = 100\mu A$, $V_{REF} - V_{FBN}$	0.985		1.015	V
FBN Line Regulation Error	$V_{IN} = 2.5V$ to $6V$, $I_{DRVN} = 100\mu A$	-5		+5	mV
FBN Effective Load Regulation Error (Transconductance)	$V_{DRVN} = -10V$, $I_{DRVN} = 50\mu A$ to $1mA$			25	mV
DRVN Source Current	$V_{FBN} = 300mV$, $V_{DRVN} = -10V$	1			mA
POSITIVE GATE-DRIVER TIMING AND CONTROL SWITCHES					
TGS Capacitor Charge Current	During startup, $V_{TGS} = 1V$	4		6	μA
TGS Turn-On Threshold		1.19		1.31	V
YV1C_ Input Low Voltage				0.6	V
YV1C_ Input High Voltage	$V_{IN} < 4.5V$	1.75			V
	$V_{IN} > 4.5V$	2.1			
GHON Input-Voltage Range				35	V

Internal-Switch Boost Regulator with Integrated Scan Driver, VCOM Calibrator, and Op Amp for TFT LCDs

ELECTRICAL CHARACTERISTICS (continued)

($V_{IN} = +3V$, Circuit of Figure 2, $V_{MAIN} = V_{SUP} = +14V$, $T_A = -40^{\circ}C$ to $+85^{\circ}C$, unless otherwise noted.)(Note 3)

PARAMETER	CONDITIONS	MIN	TYP	MAX	UNITS
GHON Input Current	YV1C_ is high, CK_, CKB_, ST_ are low, ($V_{GHON} = 32.5V$, $V_{GOFF} = -12.5V$)			1550	μA
	YV1C_ is high, CK_, CKB_, ST_ are high, ($V_{GHON} = 32.5V$, $V_{GOFF} = -12.5V$)				
GHON to GHC_ Switch On-Resistance	$V_{TGS} = 1.5V$, YV1C_ = IN			12	Ω
GHD_ to GHC_ Switch On-Resistance	$V_{TGS} = 1.5V$, YV1C_ = AGND			60	Ω
INPUT SERIES SWITCH CONTROL					
GATE Output Sink Current	GATE = IN	44		55	μA
GATE Done Voltage Threshold	$V_{IN} - V_{GATE}$			2.3	V
GATE-On Voltage	$V_{IN} = 5V$			0.61	V
BUFFER AMPLIFIERS					
SUP Supply Range		6		18	V
SUP Overvoltage Fault Threshold		18.1		19.9	V
SUP Supply Current	All op amps are no load with $V_{POS} = V_{SUP}/2$			16	mA
Input Offset Voltage	$V_{POS} = V_{SUP}/2$, $T_A = +25^{\circ}C$			16	mV
Input Common-Mode Voltage Range		0		V_{SUP}	V
Output-Voltage Swing High	$I_{OUT} = 5mA$	$V_{SUP} - 100$			mV
Output-Voltage Swing Low	$I_{OUT} = -5mA$			100	mV
Short-Circuit Current	Source: $V_{POS} = V_{SUP} - 3V$, $V_{OUT} = V_{SUP} - 4V$	115			mA
	Sink: $V_{POS} = 3V$, $V_{OUT} = 4V$	115			
VCOM OPERATIONAL AMPLIFIER					
SUP Supply Current	Buffer configuration, $V_{COMADJ} = V_{SUP}/2$, no load			4	mA
Output-Voltage Swing High	$I_{VCOM} = 75mA$	$V_{SUP} - 1.5$			V
Output-Voltage Swing Low	$I_{VCOM} = 75mA$		0.4	1.5	V
Short-Circuit Current	Buffer configuration, source: $V_{COMADJ} = V_{SUP} - 3V$, $V_{VCOM} = V_{SUP} - 4V$	115			mA
	Buffer configuration, sink: $V_{COMADJ} = 3V$, $V_{VCOM} = 4V$				

Internal-Switch Boost Regulator with Integrated Scan Driver, VCOM Calibrator, and Op Amp for TFT LCDs

ELECTRICAL CHARACTERISTICS (continued)

($V_{IN} = +3V$, Circuit of Figure 2, $V_{MAIN} = V_{SUP} = +14V$, $T_A = -40^{\circ}C$ to $+85^{\circ}C$, unless otherwise noted.)(Note 3)

PARAMETER	CONDITIONS	MIN	TYP	MAX	UNITS
PROGRAMMABLE VCOM CALIBRATOR					
SUP Input Range	For MEMORY writing	8		18	V
RSET Voltage Resolution		7			Bits
RSET Differential Nonlinearity	Monotonic overtemperature	-1		+1	LSB
RSET Zero-Scale Error		-1		+2	LSB
RSET Full-Scale Error		-4		+4	LSB
RSET Current	$V_{COMADJ} = 4V$, VCOM DAC code = 7FH			120	μA
RSET External Resistance (Note 2)	To AGND, $V_{SUP} = 18V$	8.5		170	k Ω
	To AGND, $V_{SUP} = 6V$	3.3		50	
Memory Write Cycles		30			Cycles
MTP Write Time		160		250	ms
\overline{WR} Input Low Voltage				1	V
\overline{WR} Input High Voltage		2			V
SERIAL INTERFACE					
Logic-Input Low Voltage	SDA, SCL			$0.3 \times V_{IN}$	V
Logic-Input High Voltage	SDA, SCL	$0.7 \times V_{IN}$			V
Logic-Output Low Sink Current (SDA)	SDA sink 3mA	0		0.4	V
SCL Frequency (f_{CLK})		DC		400	kHz
SCL High Time (t_{CLH})		600			ns
SCL Low Time (t_{CLL})		1300			ns
SDA and SCL Rise Time (t_R)	C_b = total capacitance of bus line in pF	20 + $0.1 \times C_b$		300	ns
SDA and SCL Fall Time (t_F)	C_b = total capacitance of bus line in pF	20 + $0.1 \times C_b$		300	ns
START Condition Hold Time (t_{HDSTT})	10% of SDA to 90% of SCL	600			ns
START Condition Setup Time (t_{SUSTT})		600			ns
Data Input Hold Time (t_{HDDAT})		200		900	ns
Data Input Setup Time (t_{SUDAT})		100			ns
STOP Condition Setup Time (t_{SUST})		600			ns
Bus Free Time (t_{BF})		1300			ns
Input Filter Spike Suppression	SDA, SCL, not tested			50	ns
RESET FUNCTION					
\overline{RST} Delay Threshold Voltage	$V_{REF} = 1.25V$	1.21		1.28	V
\overline{RST} Sink Current	$V_{RST} = 0.4V$	10			mA
LEVEL SHIFTERS					
GHON to GOFF Voltage Range	$V_{GHON} - V_{GOFF}$			45	V
GHON Input-Voltage Range				35	V
GOFF Input-Voltage Range		-15			V

Internal-Switch Boost Regulator with Integrated Scan Driver, VCOM Calibrator, and Op Amp for TFT LCDs

ELECTRICAL CHARACTERISTICS (continued)

($V_{IN} = +3V$, Circuit of Figure 2, $V_{MAIN} = V_{SUP} = +14V$, $T_A = -40^{\circ}C$ to $+85^{\circ}C$, unless otherwise noted.)(Note 3)

PARAMETER	CONDITIONS	MIN	TYP	MAX	UNITS
GHON Supply Current	YV1C_ is low, CK_, CKB_, ST_ are low, ($V_{GHON} = 32.5V$, $V_{GOFF} = -12.5V$)			830	μA
GOFF Supply Current	YV1C_ is high, CK_, CKB_, ST_ are low, ($V_{GHON} = 32.5V$, $V_{GOFF} = -12.5V$)			310	μA
	YV1C_ is high, CK_, CKB_, ST_ are high, ($V_{GHON} = 32.5V$, $V_{GOFF} = -12.5V$)			150	
CKH_, CKBH_, STH_ Output-Voltage Low	$I_{OUT_} = 10mA$			$V_{GOFF} + 1$	V
CKH_, CKBH_, STH_ Output-Voltage High	$I_{OUT_} = 10mA$	$V_{GHON} - 1$			V
ST_, CK_, CKB_ Input High Level	$V_{IN} < 4.5V$	1.6			V
	$V_{IN} > 4.5V$	2.0			
ST_, CK_, CKB_ Input Low Level				0.6	V

Note 1: For $5.5V < V_{IN} < 6.0V$, use IC for no longer than 1% of IC lifetime. For continuous operation, input voltage should not exceed 5.5V.

Note 2: RSET external resistor range is verified at DAC full scale.

Note 3: Specifications to $T_A = -40^{\circ}C$ are guaranteed by design, not production tested.

Note 4: Guaranteed by design. Not production tested.

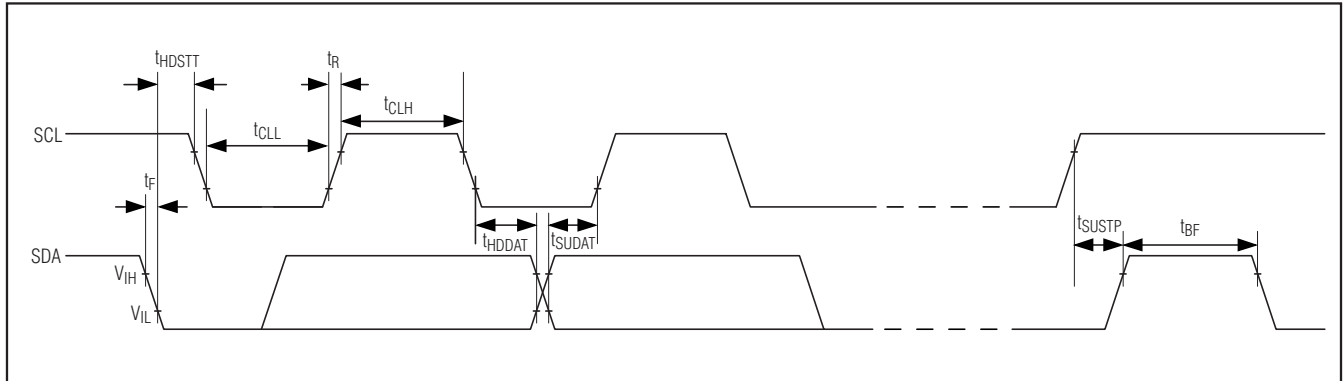
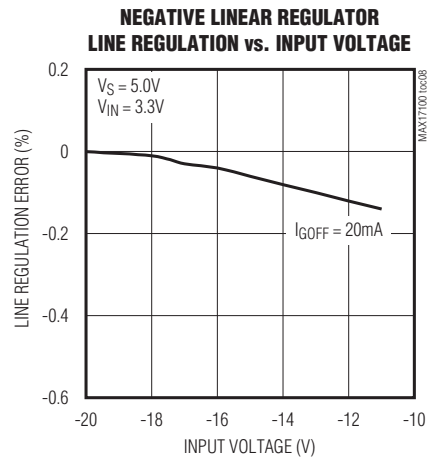
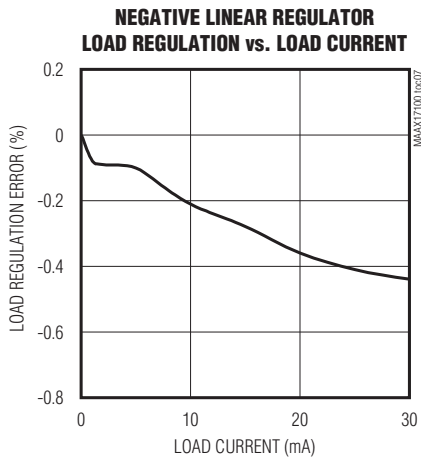
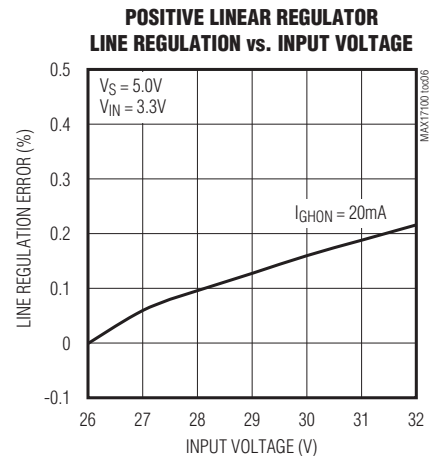
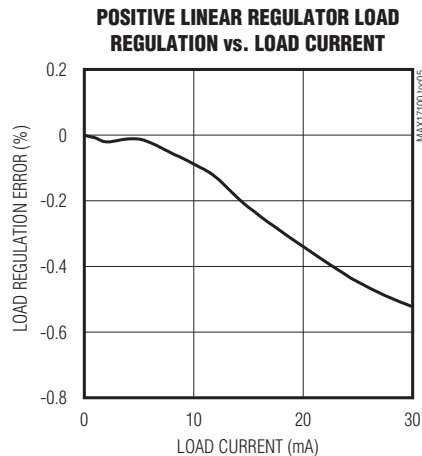
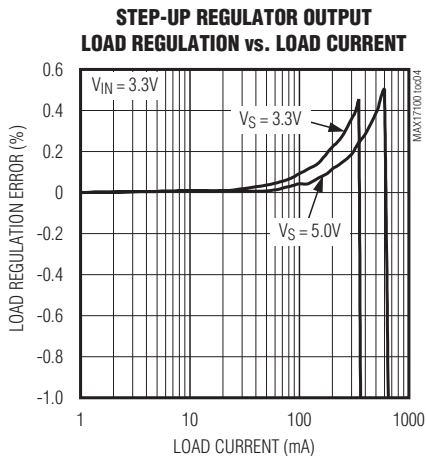
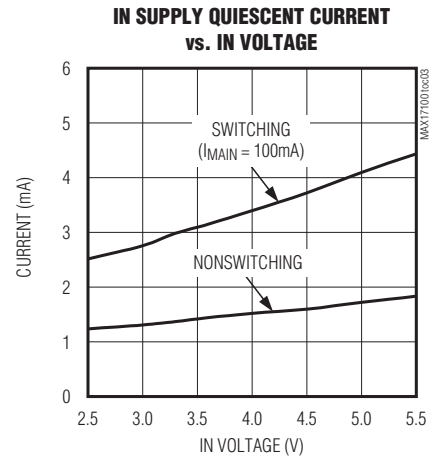
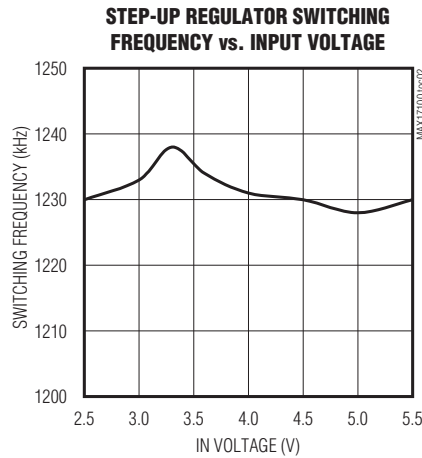
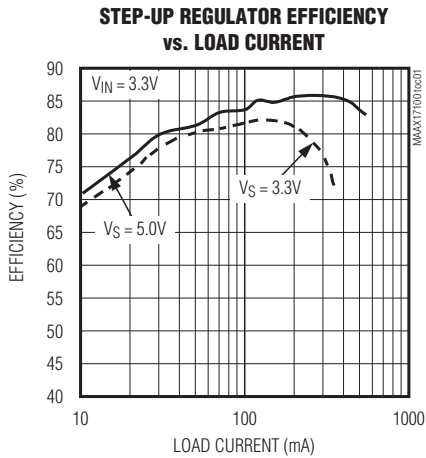

Figure 1. Timing Definitions Used in the Electrical Characteristics

Internal-Switch Boost Regulator with Integrated Scan Driver, VCOM Calibrator, and Op Amp for TFT LCDs

Typical Operating Characteristics

(Circuit of Figure 2, $V_S = 5V$, $V_{MAIN} = 14V$, $V_{GHON} = 25V$, $V_{GOFF} = -10V$, $T_A = +25^\circ C$, unless otherwise noted.)



Internal-Switch Boost Regulator with Integrated Scan Driver, VCOM Calibrator, and Op Amp for TFT LCDs

Typical Operating Characteristics (continued)

(Circuit of Figure 2, $V_S = 5V$, $V_{MAIN} = 14V$, $V_{GHON} = 25V$, $V_{GOFF} = -10V$, $T_A = +25^\circ C$, unless otherwise noted.)

STEP-UP REGULATOR SOFT-START (HEAVY LOAD)

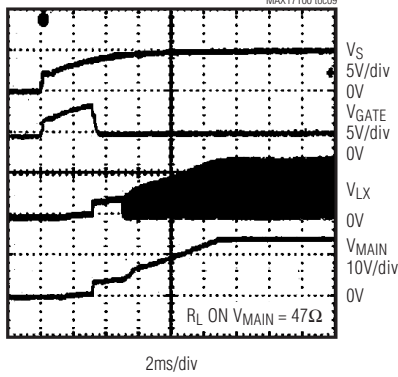

STEP-UP REGULATOR PULSED LOAD-TRANSIENT RESPONSE

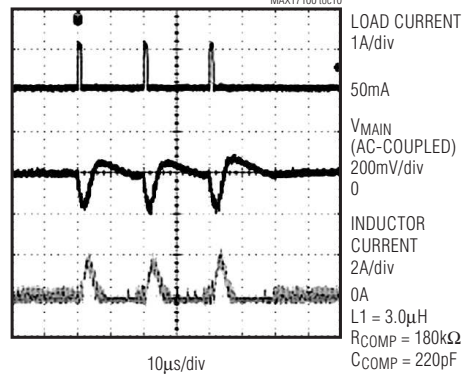

STEP-UP REGULATOR LOAD-TRANSIENT RESPONSE (50mA TO 500mA)

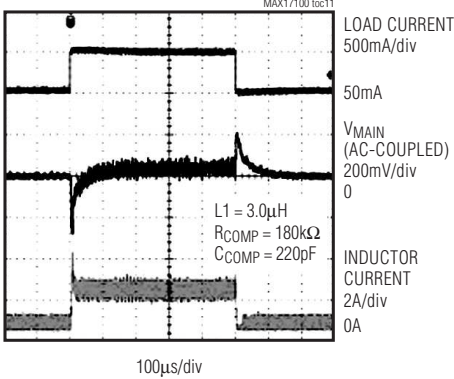

POWER-UP SEQUENCE

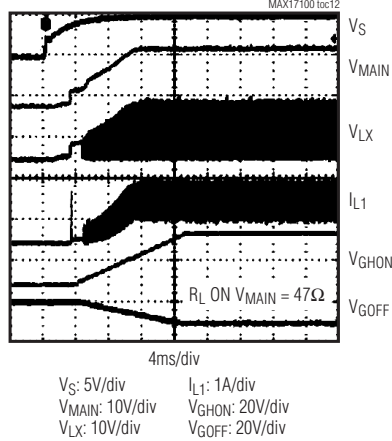

OPERATIONAL AMPLIFIER FREQUENCY RESPONSE

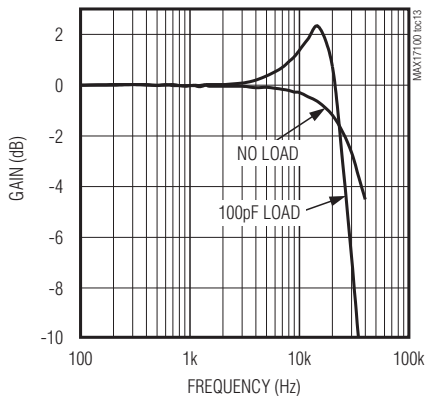

OPERATIONAL AMPLIFIER LARGE-SIGNAL STEP RESPONSE

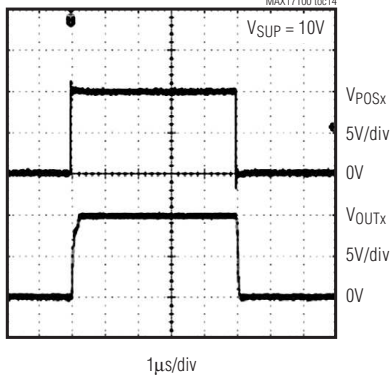

OPERATIONAL AMPLIFIER SMALL-SIGNAL STEP RESPONSE

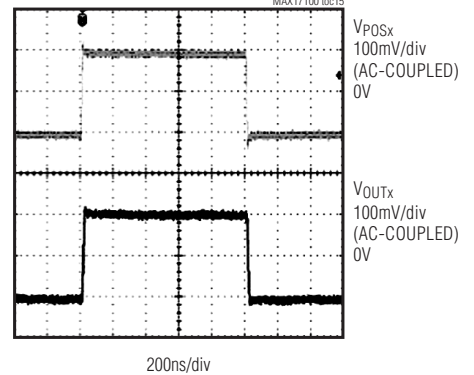

Internal-Switch Boost Regulator with Integrated Scan Driver, VCOM Calibrator, and Op Amp for TFT LCDs

Typical Operating Characteristics (continued)

(Circuit of Figure 2, $V_S = 5V$, $V_{MAIN} = 14V$, $V_{GHON} = 25V$, $V_{GOFF} = -10V$, $T_A = +25^\circ C$, unless otherwise noted.)

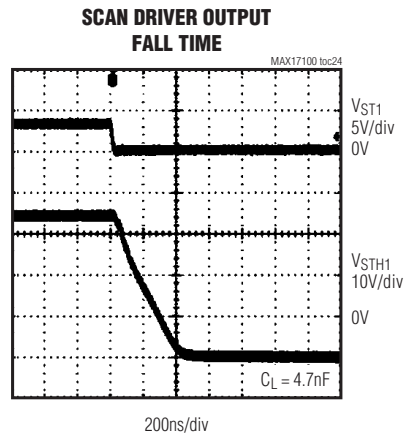
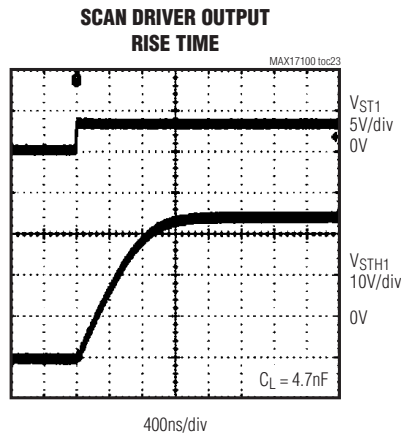
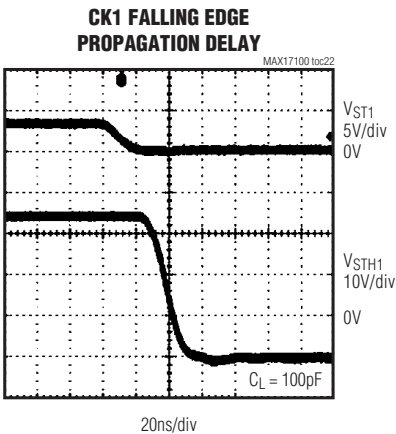
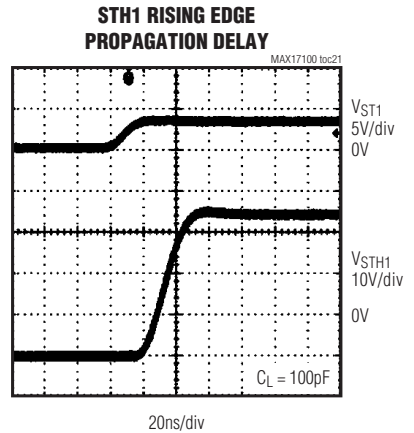
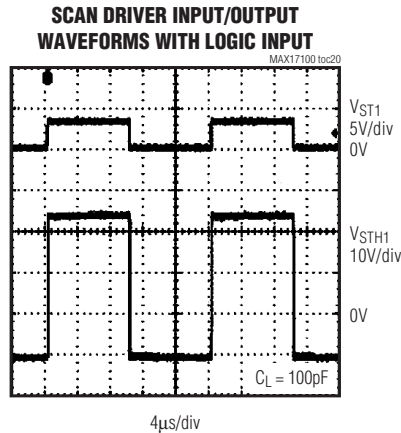
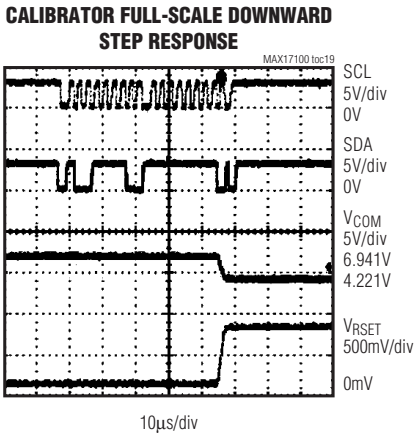
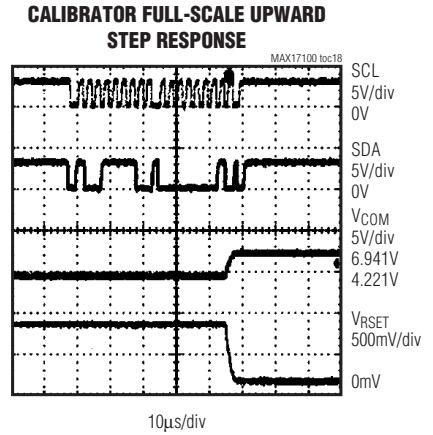
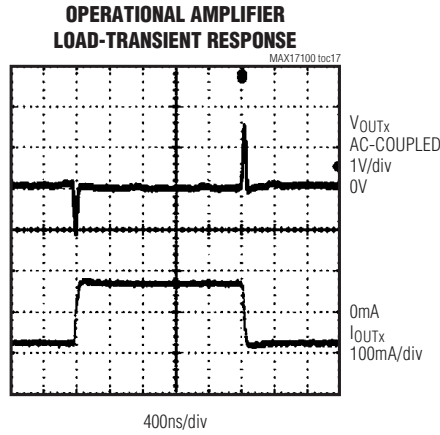
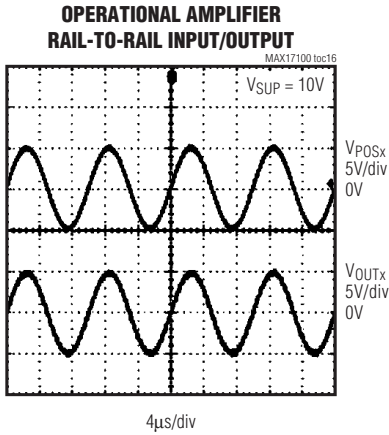

Internal-Switch Boost Regulator with Integrated Scan Driver, VCOM Calibrator, and Op Amp for TFT LCDs

Pin Description

PIN	NAME	FUNCTION
1	COMP	Step-Up Regulator Error-Amplifier Compensation Pin. Connect a series RC from COMP to AGND.
2	DRVN	Gate-Off Linear-Regulator Base-Drive Output. Open drain of an internal n-channel MOSFET. Connect DRVN to the base of an external npn pass transistor.
3	FBN	Gate-Off Linear Regulator Feedback Input. FBN regulates to 250mV (nominal). Connect FBN to the center of a resistive voltage-divider between the negative output and REF to set the gate-off linear-regulator output voltage. Place the resistive voltage-divider within 5mm of FBN.
4	REF	Reference Output. Bypass REF to AGND with a minimum 0.22 μ F capacitor close to the pin. All power outputs are disabled until REF exceeds its UVLO threshold.
5, 42	AGND	Analog Ground. Connect to power ground (PGND) under the IC.
6	FBP	Gate-On Linear-Regulator Feedback Input. FBP regulates to 1.25V (nominal). Connect FBP to the center of a resistive voltage-divider between the positive charge-pump regulator output and AGND to set the gate-on linear-regulator output voltage. Place the resistive voltage-divider within 5mm of FBP.
7	DRVP	Gate-On Linear-Regulator Base-Drive Output. Open drain of an internal n-channel MOSFET. Connect DRVP to the base of an external pnp pass transistor.
8	TGS	High-Voltage-Switch Delay Input. Connect a capacitor from TGS to AGND to set the high-voltage-switch startup delay.
9	GHON	High-Voltage-Switch Input. Source of the internal high-voltage p-channel MOSFET. Bypass GHON to PGND with a minimum of 0.1 μ F capacitor close to the pin.
10, 11	GHD_	High-Voltage-Switch Input. Drain of the internal high-voltage back-to-back p-channel MOSFETs.
12	GOFF	Gate-Off Voltage Input for Level Shifter
13	CKBH2	Level-Shifter Output
14	CKH2	Level-Shifter Output
15	STH2	Level-Shifter Output
16	CKBH1	Level-Shifter Output
17	CKH1	Level-Shifter Output
18	STH1	Level-Shifter Output
19, 26	YV1C_	High-Voltage-Switch Control Input. When YV1C_ is high, the high-voltage switch between GHON and GHC_ is on and the high-voltage switch between GHC_ and GHD_ is off. When YV1C_ is low, the switch between GHON and GHC_ is off and the switch between GHC_ and GHD_ is on. YV1C_ is inhibited by the IN undervoltage lockout and when the voltage on TGS is less than 1.25V.
20	CKB2	Level-Shifter Logic-Level Input
21	CK2	Level-Shifter Logic-Level Input
22	CKB1	Level-Shifter Logic-Level Input
23	CK1	Level-Shifter Logic-Level Input
24	ST2	Level-Shifter Logic-Level Input
25	ST1	Level-Shifter Logic-Level Input

Internal-Switch Boost Regulator with Integrated Scan Driver, VCOM Calibrator, and Op Amp for TFT LCDs

Pin Description (continued)

MAX17100

PIN	NAME	FUNCTION
27, 29, 31	POS_	Operational Amplifier Noninverting Input
28, 30, 32	OUT_	Operational Amplifier Output. OUT_ is high impedance in shutdown.
33	VCOM	VCOM Buffer Operational Amplifier Output
34	COMFB	VCOM Buffer Operational Amplifier Inverting Input
35	SUP	Operational Amplifier Supply Input. Typically connected to the output of the step-up regulator (V _{MAIN}) and bypass to OGND with a 0.47μF capacitor.
36	OGND	Analog Ground for Operational Amplifiers. Connect to power ground (PGND) underneath the IC.
37	COMADJ	VCOM Buffer Operational Amplifier Noninverting Input
38	RSET	Full-Scale Sink-Current Adjustment Input. Connect a resistor, R _{RSET} , from RSET to AGND to set the full-scale adjustable sink current I _{OUT} , which is V _{SUP} /(20 × R _{RSET}). I _{OUT} is equal to the current through R _{RSET} .
39	WR	Serial Write-Protect Input. When WR is high, I ² C write commands to update nonvolatile memory are ignored.
40	SCL	Serial Interface Clock Input. Connect a 5.6kΩ pullup resistor to IN.
41	SDA	Serial Interface Data I/O. Output is open drain. Connect a 5.6kΩ pullup resistor to IN.
43	IN	IN Supplies the Internal Reference and Other Internal Circuitry. Connect IN to the input supply voltage and bypass IN to AGND with a minimum 1μF ceramic capacitor. It is important for the loop area between the IC and the bypass capacitor, and the trace length connecting the bypass capacitor to be minimized.
44	GATE	External p-Channel MOSFET Gate Drive. It is high to keep the switch off during fault condition, including output overload, short circuit, FB fault latch, and thermal protection. Leave the pin unconnected if the external pFET is not placed.
45	LX	Step-Up Regulator Switching Node. Connect inductor and boost diode here and minimize trace area for lowest EMI.
46	PGND	Power Ground
47	RST	Reset Function Output
48	FB	Step-Up Regulator Feedback Input. FB regulates to 1.233V. Connect FB to the center of a resistive voltage-divider between the step-up regulator output and AGND to set the regulator's output voltage. Place the resistive voltage-divider within 5mm of FB.
—	EP	Exposed Pad. Connect EP to AGND.

Internal-Switch Boost Regulator with Integrated Scan Driver, VCOM Calibrator, and Op Amp for TFT LCDs

Typical Operating Circuit

The MAX17100 typical operating circuit (Figure 2) is a complete power-supply system for TFT LCDs. The circuit generates a +14V source-driver supply and +25V and

-10V gate-driver supplies. The input-voltage range for the IC is from +2.5V to +6.0V. The listed load currents in Figure 2 are available from a +4.5V to +5.5V supply. Table 1 lists some recommended components and Table 2 lists the contact information of component suppliers.

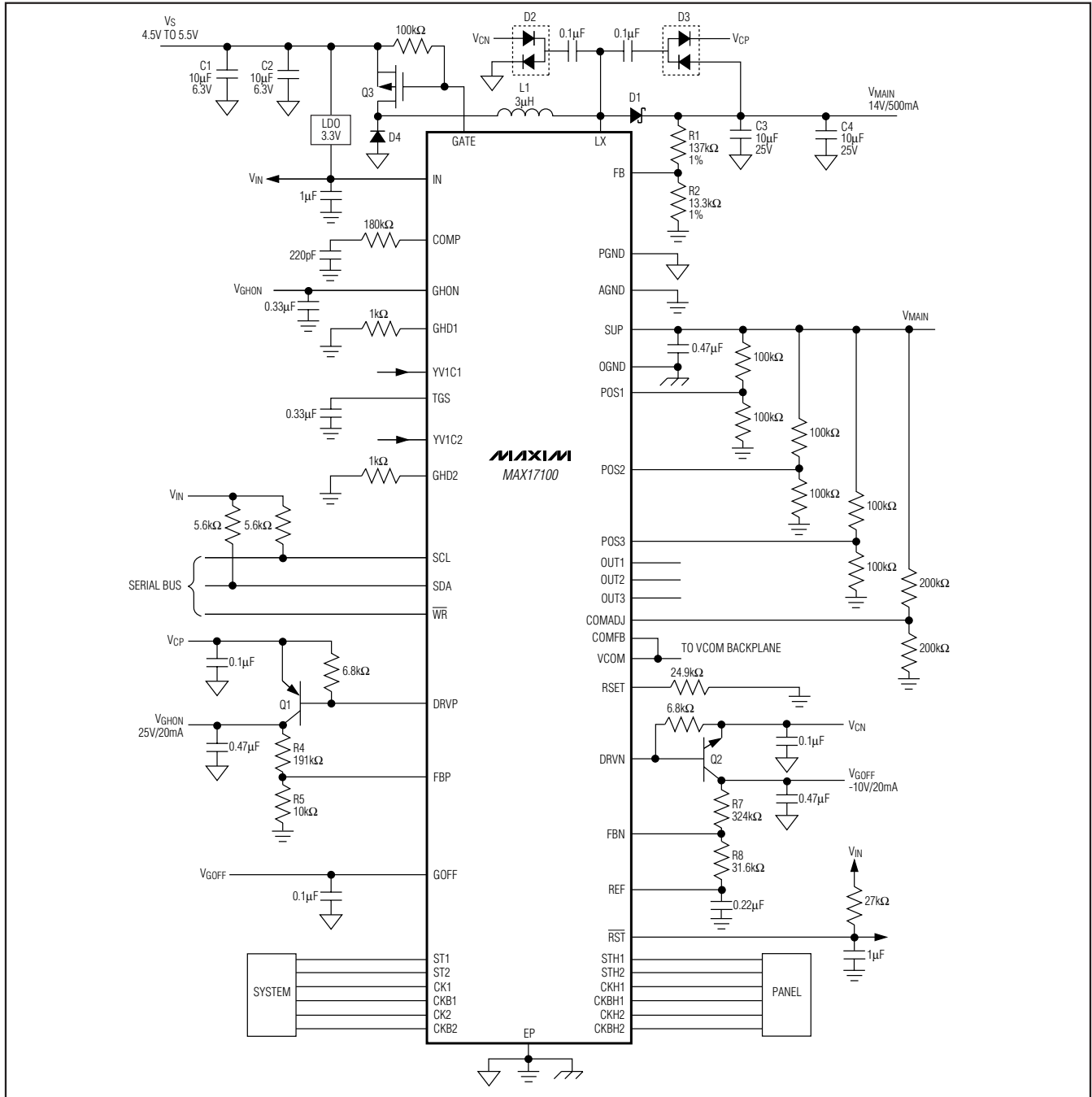

Figure 2. Typical Operating Circuit

Internal-Switch Boost Regulator with Integrated Scan Driver, VCOM Calibrator, and Op Amp for TFT LCDs

Table 1. Component List

REFERENCE DESIGNATOR	DESCRIPTION
C1, C2	10 μ F, 6.3V X5R ceramic capacitors (0603), TDK C1608X5R0J106K
C3, C4	10 μ F, 25V X5R ceramic capacitors (1206), TDK C3216X5R1E106M
D1	3A, 30V Schottky diode (M-Flat), Toshiba CMS02
D2, D3	200mA, 100V dual diodes (SOT23), Fairchild MMBD4148SE
D4	3A, 30V diode (SMA), Vishay B350A
L1	3.0 μ H, 3A inductor, Sumida CDRH6D28-3R0
Q1	200mA, 40V pnp transistor (SOT23), Fairchild MMBT3906
Q2	200mA, 40V npn transistor (SOT23), Fairchild MMBT3904
Q3	-20V/63m Ω p-channel MOSFET, Vishay PowerPak SC-70 SiA443DJ

Table 2. Component Suppliers

SUPPLIER	PHONE	FAX	WEBSITE
Fairchild	408-822-2000	408-822-2102	www.fairchildsemi.com
Sumida	847-545-6700	847-545-6720	www.sumida.com
TDK	847-803-6100	847-390-4405	www.component.tdk.com
Toshiba	949-455-2000	949-859-3963	www.toshiba.com/taec
Vishay	402-563-6866	402-563-6296	www.vishay.com

Detailed Description

The MAX17100 contains a high-performance step-up regulator, three high-current operational amplifiers, two linear regulators, two high-voltage-switch control blocks for gate-driver supply modulation, a digital VCOM calibrator, and six independent level-shifting scan drivers. Figure 3 shows the MAX17100 functional diagram.

Step-Up Regulator

The main step-up regulator employs a current-mode, fixed-frequency PWM architecture to maximize loop bandwidth and provide fast transient response to pulsed loads typical of TFT-LCD panel source drivers. The 1.2MHz switching frequency allows the use of low-profile inductors and ceramic capacitors to minimize

the thickness of LCD panel designs. The integrated high-efficiency MOSFET and the IC's built-in digital soft-start functions reduce the number of external components required while controlling inrush currents. The output voltage can be set from V_{IN} to 18V with an external resistive voltage-divider. The regulator controls the output voltage and the power delivered to the output by modulating the duty cycle (D) of the internal power MOSFET in each switching cycle. The duty cycle of the MOSFET is approximated by:

$$D \approx \frac{V_{MAIN} - V_{IN}}{V_{MAIN}}$$

Internal-Switch Boost Regulator with Integrated Scan Driver, VCOM Calibrator, and Op Amp for TFT LCDs

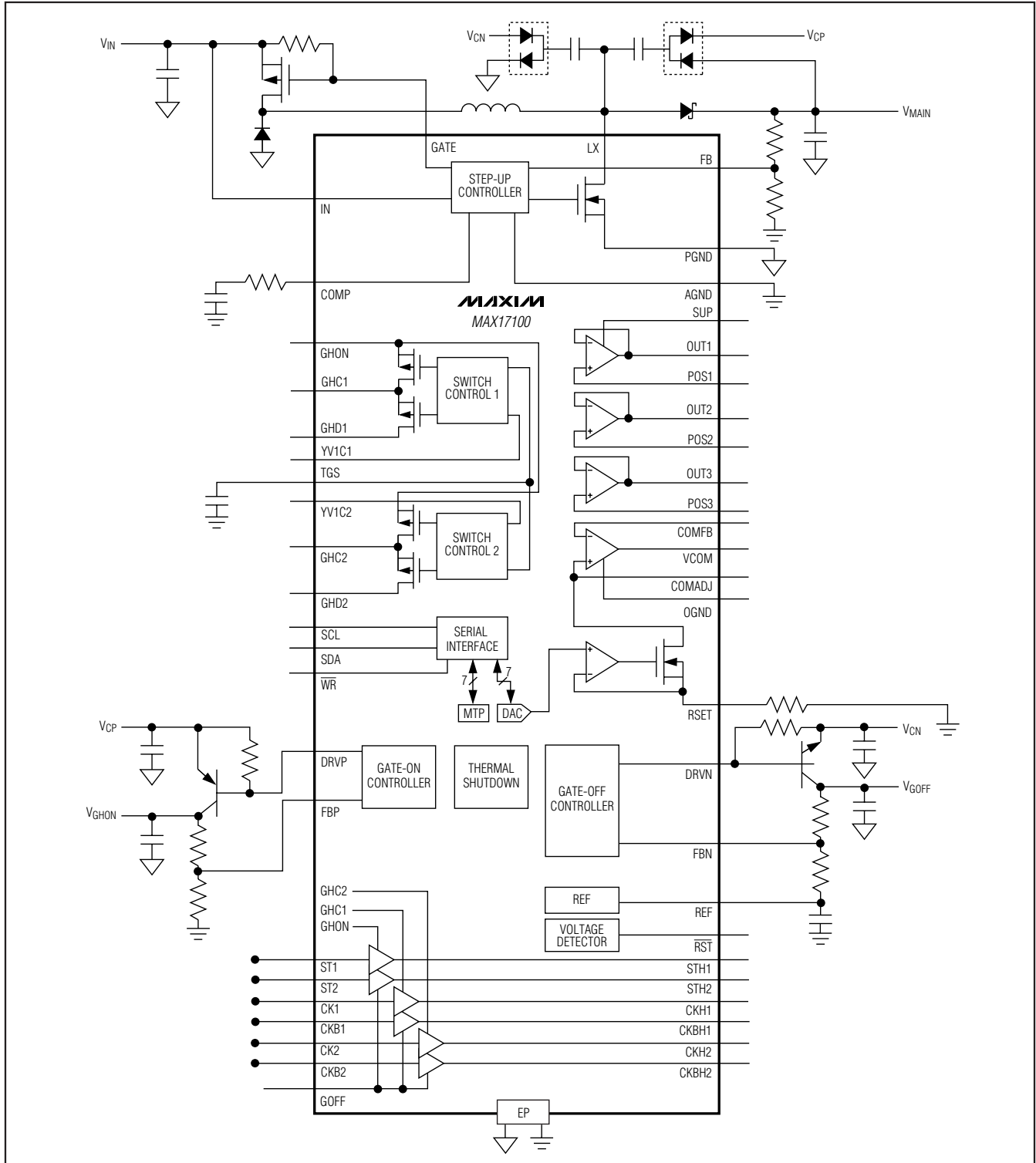

Figure 3. Functional Diagram

Internal-Switch Boost Regulator with Integrated Scan Driver, VCOM Calibrator, and Op Amp for TFT LCDs

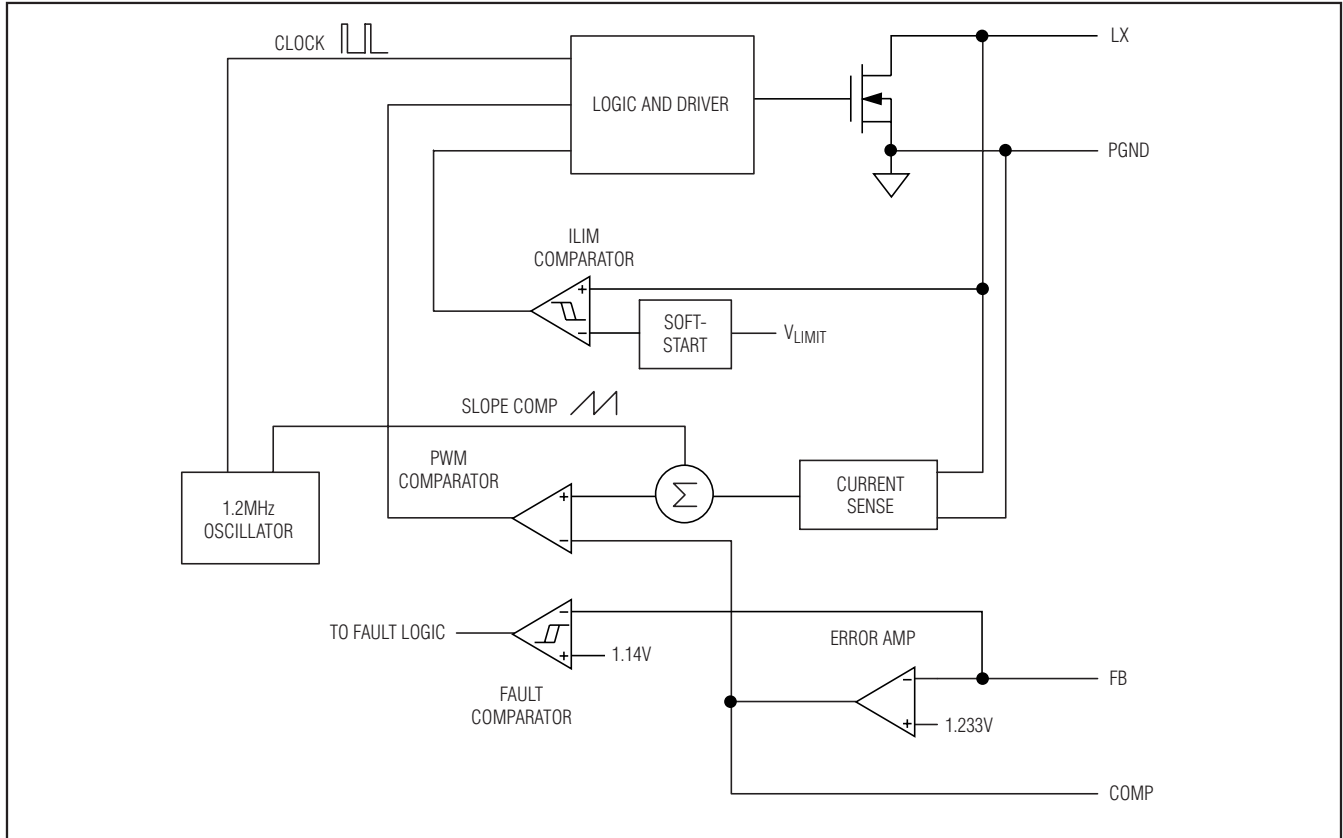

Figure 4. Step-Up Regulator Functional Diagram

Figure 4 shows the functional diagram of the step-up regulator. An error amplifier compares the signal at FB to 1.233V and changes the COMP output. The voltage at COMP sets the peak inductor current. As the load varies, the error amplifier sources or sinks current to the COMP output accordingly to produce the inductor peak current necessary to service the load. To maintain stability at high duty cycles, a slope-compensation signal is summed with the current-sense signal. On the rising edge of the internal clock, the controller sets a flip-flop, turning on the n-channel MOSFET and applying the input voltage across the inductor. The current through the inductor ramps up linearly, storing energy in its

magnetic field. Once the sum of the current-feedback signal and the slope compensation exceeds the COMP voltage, the controller resets the flip-flop and turns off the MOSFET. Since the inductor current is continuous, a transverse potential develops across the inductor that turns on the boost diode (D1). The voltage across the inductor then becomes the difference between the output voltage and the input voltage. This discharge condition forces the current through the inductor to ramp back down, transferring the energy stored in the magnetic field to the output capacitor and the load. The MOSFET remains off for the rest of the clock cycle.

Internal-Switch Boost Regulator with Integrated Scan Driver, VCOM Calibrator, and Op Amp for TFT LCDs

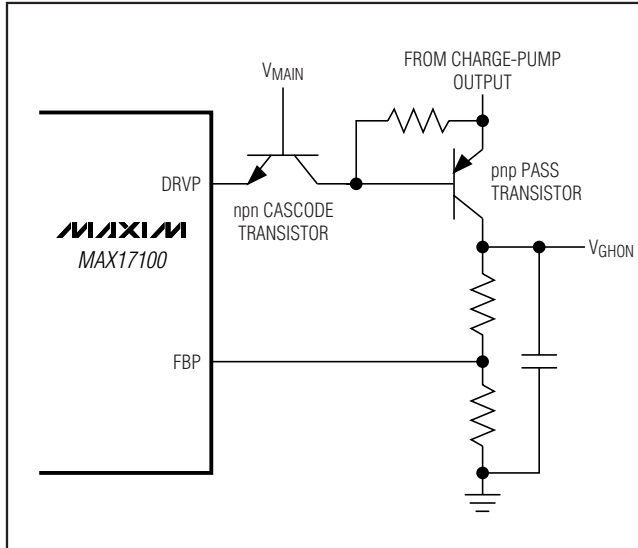

Figure 5. Using Cascaded npn for Charge-Pump Output Voltages > 36V

Gate-On Linear-Regulator Controller (REG_P)

The gate-on linear-regulator controller is an analog gain block with an open-drain n-channel output. It drives an external pnp pass transistor with a $6.8\text{k}\Omega$ base-to-emitter resistor (Figure 2). Its guaranteed base drive sink current is at least 1mA. The regulator including Q1 in Figure 2 uses a $0.47\mu\text{F}$ ceramic output capacitor and is designed to deliver 20mA at 25V. Other output voltages and currents are possible with the proper pass transistor and output capacitor. See the *Pass-Transistor Selection* and *Stability Requirements* sections. REG P is typically used to provide the TFT-LCD gate drivers' gate-on voltage. Use a charge pump with as many stages as necessary to obtain a voltage exceeding the required gate-on voltage (see the *Selecting the Number of Charge-Pump Stages* section). Note the voltage rating of DRVP is 36V. If the charge-pump output voltage can exceed 36V, an external cascode npn transistor should be added as shown in Figure 5. Alternately, the linear regulator can control an intermediate charge-pump stage while regulating the final charge-pump output (Figure 6). REG P is enabled after the GATE voltage reaches the gate-on threshold voltage (1.5V typ). Each time it is enabled, the controller goes through a soft-start routine that ramps up its internal reference DAC in 128 steps.

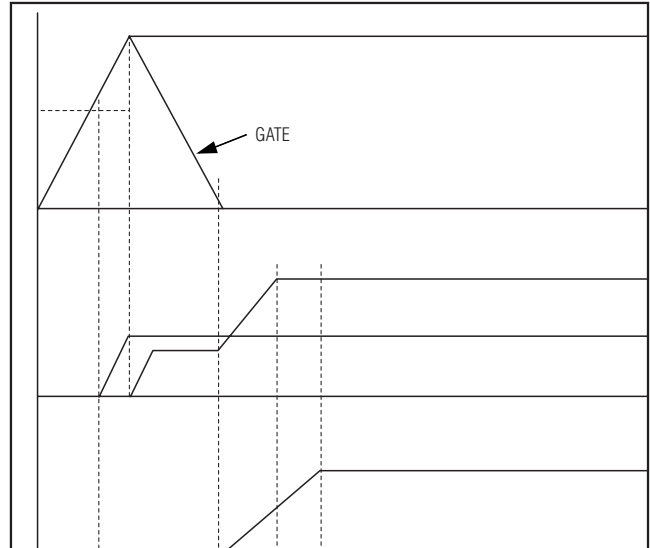

Figure 6. Linear Regulator Controls the Intermediate Charge-Pump Stage

Gate-Off Linear-Regulator Controller (REG_N)

The gate-off linear-regulator controller (REG N) is an analog gain block with an open-drain p-channel output. It drives an external npn pass transistor with a $6.8\text{k}\Omega$ base-to-emitter resistor (Figure 2). Its guaranteed base-drive source current is at least 1mA. The regulator including Q2 in Figure 2 uses a $0.47\mu\text{F}$ ceramic output capacitor and is designed to deliver 20mA at -10V. Other output voltages and currents are possible with the proper pass transistor and output capacitor (see the *Pass-Transistor Selection* and *Stability Requirements* sections). REG N is typically used to provide the TFT-LCD gate drivers' gate-off voltage. A negative voltage can be produced using a charge-pump circuit as shown in Figure 2. REG N is enabled after the GATE voltage reaches the gate-off threshold voltage (1.5V typ). Each time it is enabled, the control goes through a soft-start routine that ramps down its internal reference DAC from V_{REF} to 250mV in 128 steps.

Operational Amplifiers

The MAX17100 has three operational amplifiers. The operational amplifiers are typically used as the gamma-correction divider string. They feature $45\text{V}/\mu\text{s}$ slew rate, and 20MHz 3dB bandwidth. The rail-to-rail input and output capability maximizes application flexibility.

Internal-Switch Boost Regulator with Integrated Scan Driver, VCOM Calibrator, and Op Amp for TFT LCDs

Short-Circuit Current Limit

The operational amplifiers limit short-circuit current to approximately $\pm 200\text{mA}$ if the output is directly shorted to SUP or to OGND. If the short-circuit condition persists, the junction temperature of the IC rises until it reaches the thermal-shutdown threshold ($+160^\circ\text{C}$ typ). Once the junction temperature reaches the thermal-shutdown threshold, an internal thermal sensor immediately sets the thermal fault latch, shutting off all the IC's outputs. The device remains inactive until the input voltage is cycled.

Undervoltage Lockout (UVLO)

The UVLO circuit compares the input voltage at IN with the UVLO threshold (2.25V typ) to ensure the input voltage is high enough for reliable operation. The wider

140mV (typ) hysteresis prevents supply transients from causing a restart. Once the input voltage exceeds the UVLO rising threshold, startup procedure begins. When the input voltage falls below the UVLO falling threshold, the controller turns off the main step-up regulator and the linear regulators, pulls GATE high to turn off the external series p-channel MOSFET and disables the switch control block. The operational-amplifier outputs become high impedance at this time.

Reference Voltage (REF)

The reference output is nominally 1.25V and can source at least $50\mu\text{A}$. Bypass REF with a $0.22\mu\text{F}$ ceramic capacitor connected between REF and AGND.

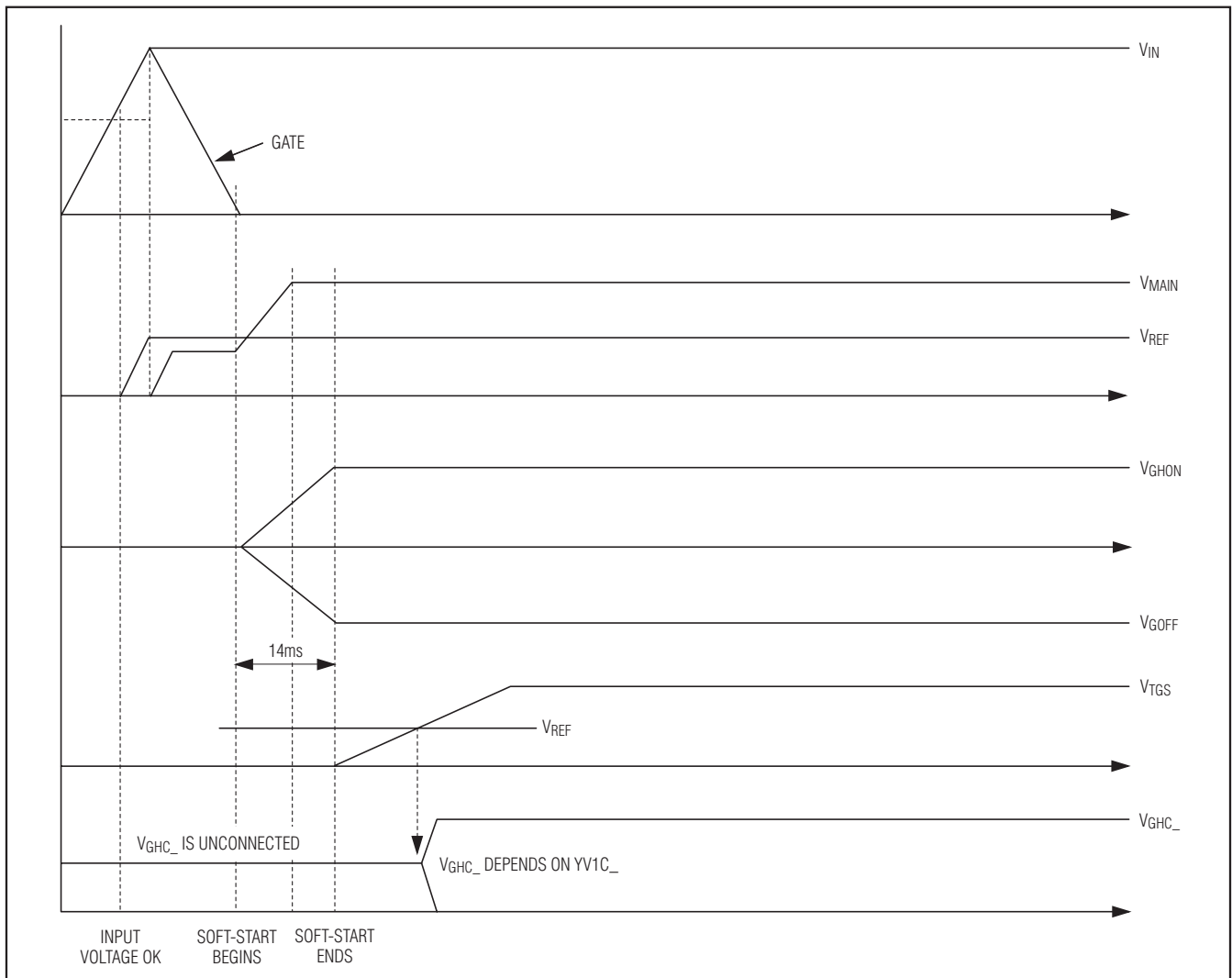

Figure 7. Power-Up Sequence

Internal-Switch Boost Regulator with Integrated Scan Driver, VCOM Calibrator, and Op Amp for TFT LCDs

Power-Up Sequence and Soft-Start

Once V_{IN} exceeds approximately 2.25V, the reference turns on. And then GATE is pulled high. When the reference voltage exceeds 1.0V (typ), GATE is pulled low to turn on the external p-channel MOSFET if no output fault is detected. Then the IC enables the main step-up regulator, the gate-on linear-regulator controller, and the gate-off linear-regulator controller simultaneously.

The IC employs soft-start for each regulator to minimize inrush current and voltage overshoot and to ensure a well-defined startup behavior. Each output uses a 7-bit soft-start DAC. For the step-up and the gate-on linear regulator, the DAC output is stepped in 128 steps from zero up to the reference voltage. For the gate-off linear regulator, the DAC output steps from the reference down to 250mV in 128 steps. The soft-start duration is 14ms (typ) for all three regulators.

A capacitor (CTGS) from TGS to AGND determines two switch-control blocks' startup delay. After the soft-start routine for each regulator is complete without any fault, a 5 μ A current source starts charging CTGS. Once the capacitor voltage exceeds 1.25V (typ), both the switch-control blocks are enabled as shown in Figure 7. After the switch-control blocks are enabled, GHC_ can be connected to GHON or GHD_ through the internal p-channel switches, depending upon the state of YV1C_. Before startup and when V_{IN} is less than UVLO, TGS is internally connected to AGND to discharge CTGS. Select CTGS to set the delay time using the following equation:

$$C_{TGS} = \text{DELAY_TIME} \times \frac{5\mu\text{A}}{1.25\text{V}}$$

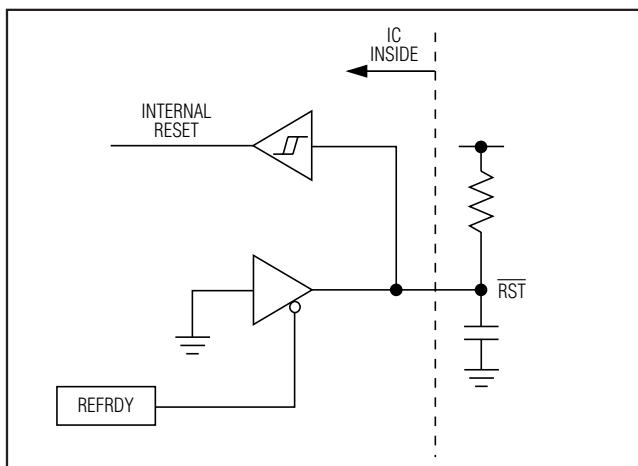

Figure 8. Reset Functional Diagram

Switch-Control Block

The switch-control inputs (YV1C1 and YV1C2) are not activated until all four of the following conditions are satisfied: the input voltage exceeds UVLO, the soft-start routine of all the regulators is complete, a no fault condition is detected, and VTGS exceeds its turn-on threshold. Once activated and if YV1C_ is high, the 6 Ω (typ) internal p-channel switch between GHON and GHC_ turns on and the 30 Ω (typ) p-channel switch between GHD_ and GHC_ turns off. If YV1C_ is low, the 6 Ω (typ) internal p-channel switch between GHON and GHC_ turns off and the 30 Ω (typ) p-channel switch between GHD_ and GHC_ turns on.

Reset Function

The MAX17100 provides a $\overline{\text{RST}}$ signal to the system for reset purpose and at the same time the signal is used internally to control the timing when IC starts to down-load data from nonvolatile setting memory to the VCOM calibrator. Below is the sequence description for reset function:

- When V_{IN} is less than 1.0V, $\overline{\text{RST}}$ is of undefined state.
- $\overline{\text{RST}}$ will be pulled low once V_{IN} exceeds 1.0V.
- Once V_{IN} exceeds V_{UVLO} , V_{REF} will start up. When V_{REF} is higher than 1.0V, $\overline{\text{RST}}$ will be released and its output becomes high impedance. External RC (Figure 8) will be charged up by their pullup voltage.
- When $\overline{\text{RST}}$ reaches the threshold voltage (1.25V) during charging up, the serial controller will start to down-load data from the nonvolatile memory to the VCOM calibrator's internal register. At this time, the system device's like timing controller will also be reset.

The sequence is shown in Figure 9.

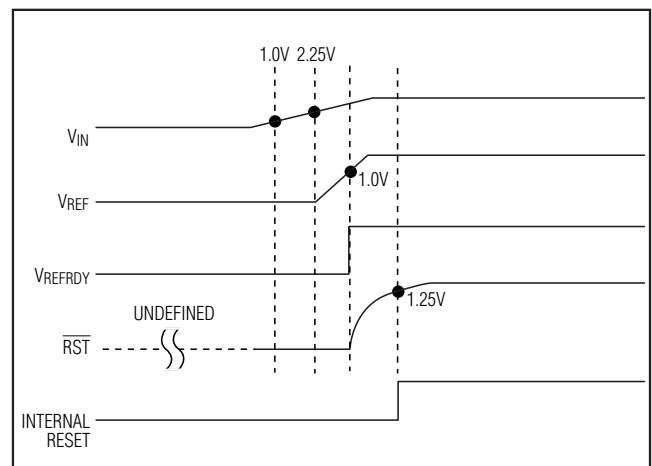

Figure 9. Reset Function Sequence

Internal-Switch Boost Regulator with Integrated Scan Driver, VCOM Calibrator, and Op Amp for TFT LCDs

XAO Function

Once V_{IN} drops below I_N UVLO, the high-side p-channel MOSFETs of the two high-voltage switch-control blocks will be forced to turn on regardless of YV1C_ and TGS. In the meantime, STH_ and CKH will be pulled high and CKBH_ will be of high-impedance state.

Fault Protection

During steady-state operation, if the output of the main regulator or any of the linear-regulator outputs does not exceed its respective fault-detection threshold, the MAX17100 activates an internal fault timer. If any condition or combination of conditions indicates a continuous fault for the fault-timer duration (218ms typ), the MAX17100 sets the fault latch to shut down all the outputs and turn off the external p-channel MOSFET (GATE is pulled high) except the reference. Once the fault condition is removed, cycle the input voltage (below the UVLO falling threshold) to clear the fault latch and reactivate the device.

The MAX17100 also provides overvoltage protection for the output of the step-up converter by monitoring the SUP pin. During normal operation, if SUP is higher than the threshold voltage (19V typ), the step-up converter will stop switching and prevent excessive voltage from damaging the MAX17100. Once SUP drops below the threshold voltage, the step-up converter will restart and regulate the needed output voltage.

Thermal-Overload Protection

Thermal-overload protection prevents excessive power dissipation from overheating the MAX17100. When the junction temperature exceeds $T_J = +160^\circ\text{C}$ (typ), a thermal sensor immediately activates the fault protection, which shuts down all outputs and turns off the external p-channel MOSFET (GATE is pulled high) except the reference, allowing the device to cool down. Cycling the input voltage (below the UVLO falling threshold) to clear the fault latch and reactivate the device. The thermal-overload protection protects the controller in the event of fault conditions. For continuous operation, do not exceed the absolute maximum junction temperature rating of $T_J = +150^\circ\text{C}$.

High-Voltage Level-Shifting Scan Driver

The MAX17100 includes six independent high-voltage level-shifting scan drivers to drive the gate lines of the TFT panel. The driver outputs (STH1, STH2, CKH1,

CKBH1, CKH2, and CKBH2) swing between their power-supply rails (V_{GHON} and V_{GOFF}) according to the input logic levels on the block's inputs (ST1, ST2, CK1, CKB1, CK2, and CKB2). The driver output is at V_{GOFF} when its respective input is logic-low, and at V_{GHON} when its respective input is logic-high. These output signals have a maximum range of +35V and -15V.

VCOM Calibrator

The VCOM calibrator is a solid-state alternative to mechanical potentiometers used for adjusting the LCD backplane voltage (VCOM) in TFT LCD displays. The noninverting input of VCOM, COMADJ, is internally connected to a programmable sink current source, which sets the VCOM level (Figure 10). An internal 7-bit DAC controls the sink current and allows the user to increase or decrease the VCOM level by a 2-wire serial interface. The DAC is ratiometrically relative to the SUP voltage and is monotonic over all operating conditions. The user stores the DAC setting in the internal nonvolatile memory block. On power-up, the MTP presets the DAC to the last stored setting. The 2-wire serial interface between the system controller and the programming circuit adjusts the DAC and programs the MTP when \overline{WR} is low. The resistive voltage-divider and the SUP supply set the maximum value of VCOM. The sink current from the voltage-divider reduces the COMADJ voltage level and VCOM output. The external resistor at RRSET sets the full-scale sink current and the minimum value of VCOM.

Driving Pure Capacitive Load

In general, the LCD backplane (VCOM) consists of a distributed series capacitance and resistance, a load that can be easily driven by the operational amplifier. However, if the operational amplifier is used in an application with a pure capacitive load, steps must be taken to ensure stable operation.

As the operational amplifier's capacitive load increases, the amplifier's bandwidth decreases and gain peaking increases. A 5Ω to 50Ω small resistor placed between OUT_ and the capacitive load reduces peaking but also reduces the gain. An alternative method of reducing peaking is to place a series RC network (snubber) in parallel with the capacitive load. The RC network does not continuously load the output or reduce the gain. Typical values of the resistor are between 100Ω and 200Ω , and the typical value of the capacitor is 10nF.

Internal-Switch Boost Regulator with Integrated Scan Driver, VCOM Calibrator, and Op Amp for TFT LCDs

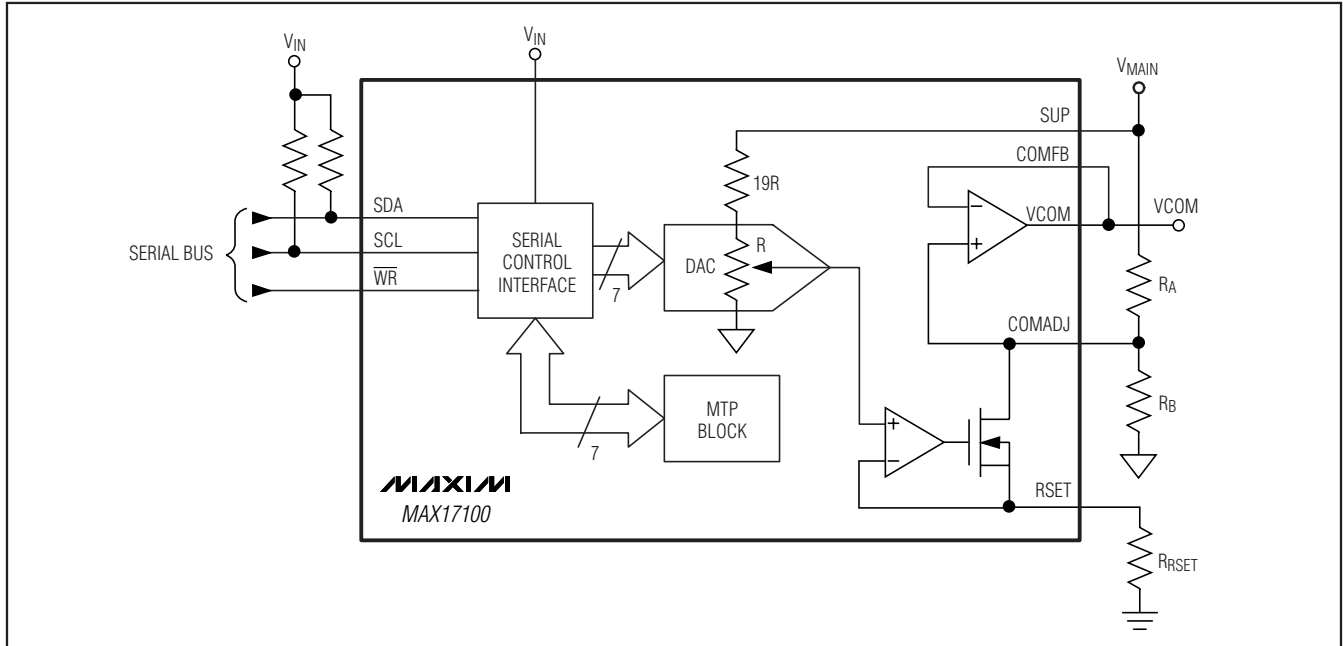

Figure 10. VCOM Calibrator Functional Diagram

Design Procedures

Step-Up Regulator

Inductor Selection

The minimum inductance value, peak current rating, and series resistance are factors to consider when selecting the inductor. These factors influence the converter's efficiency, maximum output load capability, transient-response time, and output voltage ripple. Size and cost are also important factors to consider.

The maximum output current, input voltage, output voltage, and switching frequency determine the inductor value. Very high inductance values minimize the current ripple and therefore reduce the peak current, which decreases core losses in the inductor and conduction losses in the entire power path. However, large inductor values also require more energy storage and more turns of wire, which increase size and can increase conduction losses in the inductor. Low inductance values decrease the size but increase the current ripple and peak current. Finding the best inductor involves choosing the best compromise between circuit efficiency, inductor size, and cost.

The equations used here include a constant LIR, which is the ratio of the inductor peak-to-peak ripple current to the average DC inductor current at the full load current. The best trade-off between inductor size and circuit

efficiency for step-up regulators generally has an LIR between 0.3 and 0.6. However, depending on the AC characteristics of the inductor core material and ratio of inductor resistance to other power-path resistances, the best LIR can shift up or down. If the inductor resistance is relatively high, more ripple can be accepted to reduce the number of turns required and increase the wire diameter. If the inductor resistance is relatively low, increasing inductance to lower the peak current can decrease losses throughout the power path. If extremely thin high-resistance inductors are used, as is common for LCD-panel applications, the best LIR can increase to between 0.5 and 1.0.

Once a physical inductor is chosen, higher and lower values of the inductor should be evaluated for efficiency improvements in typical operating regions.

Calculate the approximate inductor value using the typical input voltage (V_{IN}), the maximum output current ($I_{MAIN(MAX)}$), the expected efficiency (η_{TYP}) taken from an appropriate curve in the *Typical Operating Characteristics* section, and an estimate of LIR based on the above discussion:

$$L = \left(\frac{V_{IN}}{V_{MAIN}} \right) \left(\frac{V_{MAIN} - V_{IN}}{I_{MAIN(MAX)} \times f_{OSC}} \right) \left(\frac{\eta_{TYP}}{LIR} \right)$$

Internal-Switch Boost Regulator with Integrated Scan Driver, VCOM Calibrator, and Op Amp for TFT LCDs

Choose an available inductor value from an appropriate inductor family. Calculate the maximum DC input current at the minimum input voltage ($V_{IN(MIN)}$) using conservation of energy and the expected efficiency at that operating point (η_{MIN}) taken from the appropriate curve in the *Typical Operating Characteristics*:

$$I_{N(DC,MAX)} = \frac{I_{MAIN(MAX)} \times V_{MAIN}}{V_{IN(MIN)} \times \eta_{MIN}}$$

Calculate the ripple current at that operating point and the peak current required for the inductor:

$$I_{RIPPLE} = \frac{V_{IN(MIN)} \times (V_{MAIN} - V_{IN(MIN)})}{L \times V_{MAIN} \times f_{OSC}}$$

$$I_{PEAK} = I_{N(DC,MAX)} + \frac{I_{RIPPLE}}{2}$$

The inductor's saturation current rating and the MAX17100's LX current limit (I_{LIM}) should exceed I_{PEAK} , and the inductor's DC current rating should exceed $I_{N(DC,MAX)}$. For good efficiency, choose an inductor with less than 0.1Ω series resistance.

Considering the typical operating circuit, the maximum load current ($I_{MAIN(MAX)}$) is 500mA with a 14V output and a typical input voltage of 5V. Choosing an LIR of 0.55 and estimating efficiency of 85% at this operating point:

$$L = \left(\frac{5V}{14V}\right)^2 \left(\frac{14V - 5V}{0.5A \times 1.2MHz}\right) \left(\frac{0.85}{0.55}\right) \approx 3.0\mu H$$

Using the circuit's minimum input voltage (4.5V) and estimating efficiency of 80% at that operating point:

$$I_{N(DC,MAX)} = \frac{0.5A \times 14V}{4.5V \times 0.8} = 1.94A$$

The ripple current and the peak current are:

$$I_{RIPPLE} = \frac{4.5V \times (14V - 4.5V)}{3.0\mu H \times 14V \times 1.2MHz} = 0.848A$$

$$I_{PEAK} = 1.94A + \frac{0.848A}{2} \approx 2.36A$$

Output-Capacitor Selection

The total output voltage ripple has two components: the capacitive ripple caused by the charging and discharging of the output capacitance, and the ohmic ripple due to the capacitor's equivalent series resistance (ESR):

$$V_{RIPPLE} = V_{RIPPLE(C)} + V_{RIPPLE(ESR)}$$

$$V_{RIPPLE(C)} \approx \frac{I_{MAIN}}{C_{OUT}} \left(\frac{V_{MAIN} - V_{IN}}{V_{MAIN} \times f_{OSC}}\right)$$

and

$$V_{RIPPLE(ESR)} \approx I_{PEAK} \times R_{ESR(COUT)}$$

where I_{PEAK} is the peak inductor current (see the *Inductor Selection* section). For ceramic capacitors, the output voltage ripple is typically dominated by $V_{RIPPLE(C)}$. The voltage rating and temperature characteristics of the output capacitor must also be considered.

Input-Capacitor Selection

The input capacitor (C_{IN}) reduces the current peaks drawn from the input supply and reduces noise injection into the IC. Two $10\mu F$ ceramic capacitors are used in the typical applications circuit (Figure 2) because of the high source impedance seen in typical lab setups. Actual applications usually have much lower source impedance since the step-up regulator often runs directly from the output of another regulated supply. Typically, C_{IN} can be reduced below the values used in the typical applications circuit. Ensure a low-noise supply at IN by using adequate C_{IN} .

Rectifier Diode

The MAX17100's high switching frequency demands a high-speed rectifier. Schottky diodes are recommended for most applications because of their fast recovery time and low forward voltage. In general, a 3A Schottky diode complements the internal MOSFET well.

Output-Voltage Selection

The output voltage of the main step-up regulator can be adjusted by connecting a resistive voltage-divider from the output (V_{MAIN}) to AGND with the center tap connected to FB (see Figure 2). Select R2 in the $10k\Omega$ to $50k\Omega$ range. Calculate R1 with the following equation:

$$R1 = R2 \times \left(\frac{V_{MAIN}}{V_{FB}} - 1\right)$$

where V_{FB} , the step-up regulator's feedback set point, is 1.233V. Place R1 and R2 close to the IC.