



Chipsmall Limited consists of a professional team with an average of over 10 year of expertise in the distribution of electronic components. Based in Hongkong, we have already established firm and mutual-benefit business relationships with customers from,Europe,America and south Asia,supplying obsolete and hard-to-find components to meet their specific needs.

With the principle of "Quality Parts,Customers Priority,Honest Operation,and Considerate Service",our business mainly focus on the distribution of electronic components. Line cards we deal with include Microchip,ALPS,ROHM,Xilinx,Pulse,ON,Everlight and Freescale. Main products comprise IC,Modules,Potentiometer,IC Socket,Relay,Connector.Our parts cover such applications as commercial,industrial, and automotives areas.

We are looking forward to setting up business relationship with you and hope to provide you with the best service and solution. Let us make a better world for our industry!



Contact us

Tel: +86-755-8981 8866 Fax: +86-755-8427 6832

Email & Skype: info@chipsmall.com Web: www.chipsmall.com

Address: A1208, Overseas Decoration Building, #122 Zhenhua RD., Futian, Shenzhen, China





MAX17103 Evaluation Kit

General Description

The MAX17103 evaluation kit (EV kit) is a fully assembled and tested surface-mount PCB that provides the voltages and features required for active-matrix, thin-film transistor (TFT), liquid-crystal display (LCD) applications. The EV kit contains a high-performance step-up regulator, a 350mA low-dropout linear regulator, a high-speed operational amplifier (op amp), a positive charge pump for the TFT gate-on supply, a negative charge pump with a negative linear regulator controller for the TFT gate-off supply, and a high-voltage, level-shifting scan driver.

The EV kit operates from a DC supply voltage of +2.3V to +5.5V. The step-up switching regulator is configured for a +8.5V output providing at least 250mA from a +2.7V input. The positive charge pump is configured to provide a +23V output providing at least 20mA. The negative charge pump with negative linear controller is configured to provide a -6V output providing at least 20mA. The op amp is configured for +4.25V and has a $\pm 200\text{mA}$ (typ) output short-circuit current. The high-voltage, level-shifting scan driver buffers three logic inputs and shifts them to a desired level to drive TFT-LCD row logic.

Features

- ◆ +2.3V to +5.5V Input Range
- ◆ Output Voltages
 - +8.5V Output at 250mA from a +2.7V Input (Step-Up Switching Regulator)
 - +23V Output at 20mA (Positive Charge Pump)
 - 6V Output at 20mA (Negative Charge Pump with Negative Linear Regulator Controller)
 - +4.25V High-Current Op-Amp Output ($\pm 200\text{mA}$ (typ))
- ◆ Resistor-Adjustable Switching-Regulator, Op-Amp Output, VGL, and LDOO Voltages
- ◆ Three High-Voltage Level-Shifting Buffers
- ◆ 1.2MHz Step-Up Switching Frequency
- ◆ Lead(Pb)-Free and RoHS Compliant
- ◆ Fully Assembled and Tested

Ordering Information

PART	TYPE
MAX17103EVKIT+	EV Kit

+Denotes lead(Pb)-free and RoHS compliant.

Component List

DESIGNATION	QTY	DESCRIPTION
C1	1	10 μF $\pm 10\%$, 10V X5R ceramic capacitor (0805) TDK C2012X5R1A106K Murata GRM21BR61A106K
C2, C3, C4	3	10 μF $\pm 10\%$, 16V X5R ceramic capacitors (1206) Murata GRM31CR61C106K TDK C3216X5R1C106K
C5	1	0.22 μF $\pm 10\%$, 50V X7R ceramic capacitor (0805) Murata GRM21BR71H224K TDK C2012X7R1H224K
C6–C11, C15, C16, C17, C21	10	0.1 μF $\pm 10\%$, 50V X7R ceramic capacitors (0603) Murata GRM188R71H104K TDK C1608X7R1H104K
C18, C22, C33	3	0.22 μF $\pm 10\%$, 25V X5R ceramic capacitors (0603) Murata GRM188R61E224K TDK C1608X5R1E224K

DESIGNATION	QTY	DESCRIPTION
C12, C13, C14	3	1 μF $\pm 10\%$, 16V X5R ceramic capacitors (0603) Murata GRM188R61C105K TDK C1608X5R1C105K
C19	1	1000pF $\pm 10\%$, 50V X7R ceramic capacitor (0603) Murata GRM188R71H102K TDK C1608X7R1H102K
C20	1	0.33 μF $\pm 10\%$, 10V X5R ceramic capacitor (0603) Murata GRM188R61A334K TDK C1608X5R1A334K
C26, C27, C28, C34	0	Not installed, ceramic capacitors (0603)
C29, C30, C31	3	3300pF $\pm 10\%$, 50V X7R ceramic capacitors (0603) Murata GRM188R71H332K TDK C1608X8R1H332K



MAX17103 Evaluation Kit

Component List (continued)

DESIGNATION	QTY	DESCRIPTION
C32	1	1 μ F \pm 10%, 25V X5R ceramic capacitor (0805) Murata GRM21BR71E105K TDK C2012X5R1E105K
D1	1	1A, 30V Schottky diode (S-Flat) Central Semi CMMSH1-40 LEAD FREE Nihon EP10QY03 Toshiba CRS02(TE85L,Q,M)
D2, D3, D4	3	200mA, 100V dual diodes (SOT23) Fairchild MMBD4148SE (Top Mark: D4) Central Semi CMPD7000+ (Top Mark: C5C)
JU1	1	3-pin header
LX, POS, QS, REF, VDET	5	PCB mini test points
L1	1	10 μ H, 1.85A, 74.4m Ω inductor (6mm x 6mm x 3mm) Sumida CDRH5D28RHPNP-100M
Q1	1	nnp surface-mount transistor (SOT23) Diodes, Inc. MMBT3904 Fairchild MMBT3904
R1	1	102k Ω \pm 1% resistor (0603)
R2	1	17.4k Ω \pm 1% resistor (0603)
R3, R4, R5	3	56.2k Ω \pm 1% resistors (0603)

DESIGNATION	QTY	DESCRIPTION
R6	1	1.2k Ω \pm 5% resistor (0603)
R7, R27, R28, R29	0	Not installed, resistors—shorted by PC trace (0603)
R8	1	62k Ω \pm 5% resistor (0603)
R9	1	51.1k Ω \pm 1% resistor (0603)
R10, R26	2	49.9k Ω \pm 1% resistors (0603)
R11	1	82.5k Ω \pm 1% resistor (0603)
R12	1	110k Ω \pm 1% resistor (0603)
R13	1	2.2k Ω \pm 5% resistor (0603)
R14	1	6.81k Ω \pm 1% resistor (0603)
R15	1	243k Ω \pm 1% resistor (0603)
R16–R21, R31–R36	12	200 Ω \pm 1% resistors (1206)
R22–R25	4	100k Ω \pm 5% resistors (0603)
R30	0	Not installed, resistor (0805)
SW1	1	4-position low-profile surface-mount DIP switch
U1	1	Internal-switch boost regulator (32 TQFN-EP*) Maxim MAX17103ETJ+
—	1	Shunt
—	1	PCB: MAX17103 Evaluation Kit+

*EP = Exposed pad.

Component Suppliers

SUPPLIER	PHONE	WEBSITE
Central Semiconductor Corp.	631-435-1110	www.centralsemi.com
Diodes, Inc.	805-446-4800	www.diodes.com
Fairchild Semiconductor	888-522-5372	www.fairchildsemi.com
Murata Electronics North America, Inc.	770-436-1300	www.murata-northamerica.com
Nihon Inter Electronics Corp.	847-843-7500	www.niec.co.jp
Sumida Corp.	847-545-6700	www.sumida.com
TDK Corp.	847-803-6100	www.component.tdk.com
Toshiba America Electronic Components, Inc.	949-623-2900	www.toshiba.com/taec

Note: Indicate that you are using the MAX17103 when contacting these component suppliers.

MAX17103 Evaluation Kit

Evaluates: MAX17103

Quick Start

Recommended Equipment

- 2.3V to 5.5V, 2A DC power supply
- Voltmeters

Procedure

The MAX17103 EV kit is fully assembled and tested. Follow the steps below to verify board operation.

Caution: Do not turn on the power supply until all connections are completed.

- 1) Verify that a shunt is installed across pins 1-2 of jumper JU1.
- 2) Verify that SW1 4-position DIP switches are in the on position.
- 3) Connect the positive terminal of the power supply to the VIN pad. Connect the negative terminal of the power supply to the PGND pad. Set VIN to +3V.
- 4) Turn on the power supply and verify that the step-up switching regulator output (VMAIN) is +8.5V.
- 5) Verify that the gate-on supply (GHON) is approximately +23V.
- 6) Verify that the gate-off supply (VGL) is approximately -6V.
- 7) Verify that the output of the high-speed op amp (VOUT) is approximately +4.25V.
- 8) Verify that the outputs of the high-voltage level-shifting buffers are approximately +23V (= GHON).

Detailed Description of Hardware

The MAX17103 EV kit contains a step-up switching regulator, a positive two-stage charge pump, a negative single-stage charge pump with a negative linear regulator controller, a high-speed op amp, and three high-voltage level-shifting buffers for scan-driver applications. The EV kit operates from a DC power supply between +2.3V and +5.5V.

As configured, the step-up switching regulator (VMAIN) generates a +8.5V output and provides at least 250mA from a +2.7V input. The step-up switching-regulator output voltage can be adjusted up to +15V with different feedback resistors (see the *Output-Voltage Selection* section).

The GHON consists of two positive charge-pump stages to generate approximately +23V and provides up to 20mA. The VGL consists of a single negative charge-pump stage regulated with the negative linear controller to generate approximately -6V and provides up to 20mA. Loading GHON and VGL reduces the available VMAIN current proportionally.

The op-amp output (VOUT) is set to +4.25V and sources or sinks current up to 200mA (typ). The output can be reconfigured to other voltages with voltage-divider resistors (see the *Output-Voltage Selection* section).

The three logic-level to high-voltage level and shifting buffers can buffer three logic inputs (CK, XCK, and ST) and shift them to the desired output levels (CKH, XCKH, and STH) to drive TFT-LCD row logic. The driver outputs swing between their power-supply rails (GHON and VGL) according to the input logic levels on the block's inputs (CK, XCK, CS, and ST), and by internal logic used during power-up and power-down. For further details, refer to the *High-Voltage Level-Shifting Scan Driver* section in the MAX17103 IC data sheet.

The four switches within SW1 are used to select logic levels on CK, CS, XCK, and ST for testing purposes. Set each switch open when driving CK, CS, XCK, and ST with external logic.

Jumper Selection (JU1)

The MAX17103 EV kit incorporates jumper JU1 to control the chip enable control. See Table 1 for jumper JU1 functions.

Output-Voltage Selection

Step-Up Switching-Regulator Output Voltage (VMAIN)

The MAX17103 EV kit's step-up switching-regulator output (VMAIN) is set to +8.5V by feedback resistors R1 and R2. To generate output voltages other than +8.5V (up to +15V), select different external voltage-divider resistors R1 and R2. For instructions on selecting the step-up switching regulator feedback divider resistors for other output voltages, refer to the *Output-Voltage Selection* section in the MAX17103 IC data sheet.

Table 1. Jumper JU1 Functions

SHUNT POSITION	ENA PIN	EV KIT OUTPUTS
1-2*	ENA connected to LDOO through R8	Outputs enabled (VMAIN = +8.5V)
2-3	ENA connected to GND through R8	Outputs disabled (VMAIN ~ VIN)

*Default position.

MAX17103 Evaluation Kit

Note that changing the VMAIN voltage setting changes the GHON and VGL charge-pump output voltages. The voltage range of VGL is limited to -15V. The voltage range of GHON is limited to +35V. The voltage difference between GHON and VGL should not exceed +40V. If VMAIN is set for more than +11V, disconnect the positive and negative charge pump with the negative linear regulator controller by cutting the R29 and R28 traces. Apply power to GHON and VGL by connecting external power supplies to their respective pads.

Op-Amp Output Voltage (VOUT)

The MAX17103 EV kit's op amp is configured internally as a unity gain buffer. The voltage at the noninverting input (POS) is set to half of VMAIN by voltage-divider resistors R4 and R5. To set VOUT to other voltages (up to VMAIN), select different divider resistors according to the following equation:

$$R4 = R5 \times \left(\frac{VMAIN}{VOUT} - 1 \right)$$

MAX17103 Evaluation Kit

Evaluates: MAX17103

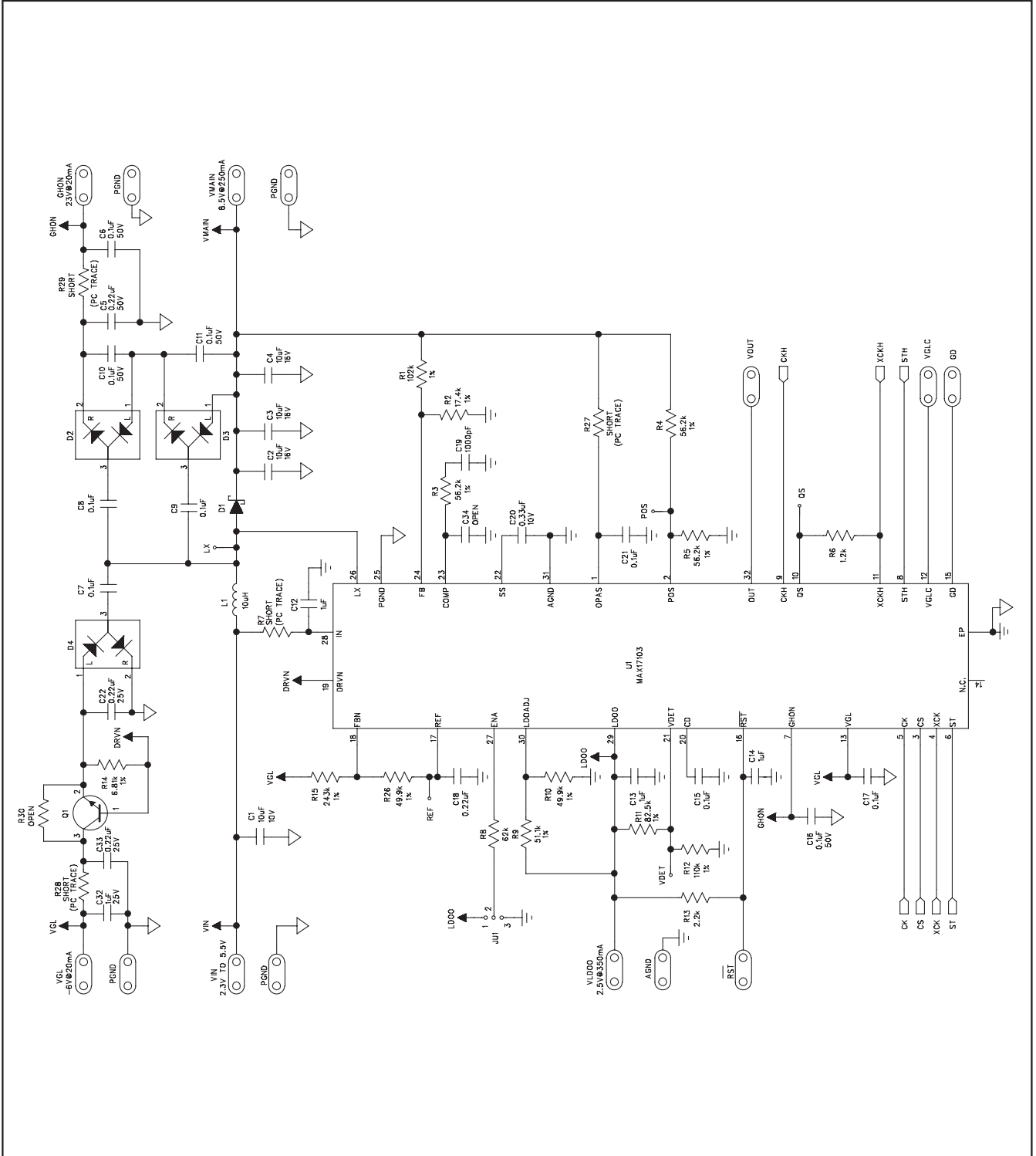

Figure 1a. MAX17103 EV Kit Schematic (Sheet 1 of 2)

MAX17103 Evaluation Kit

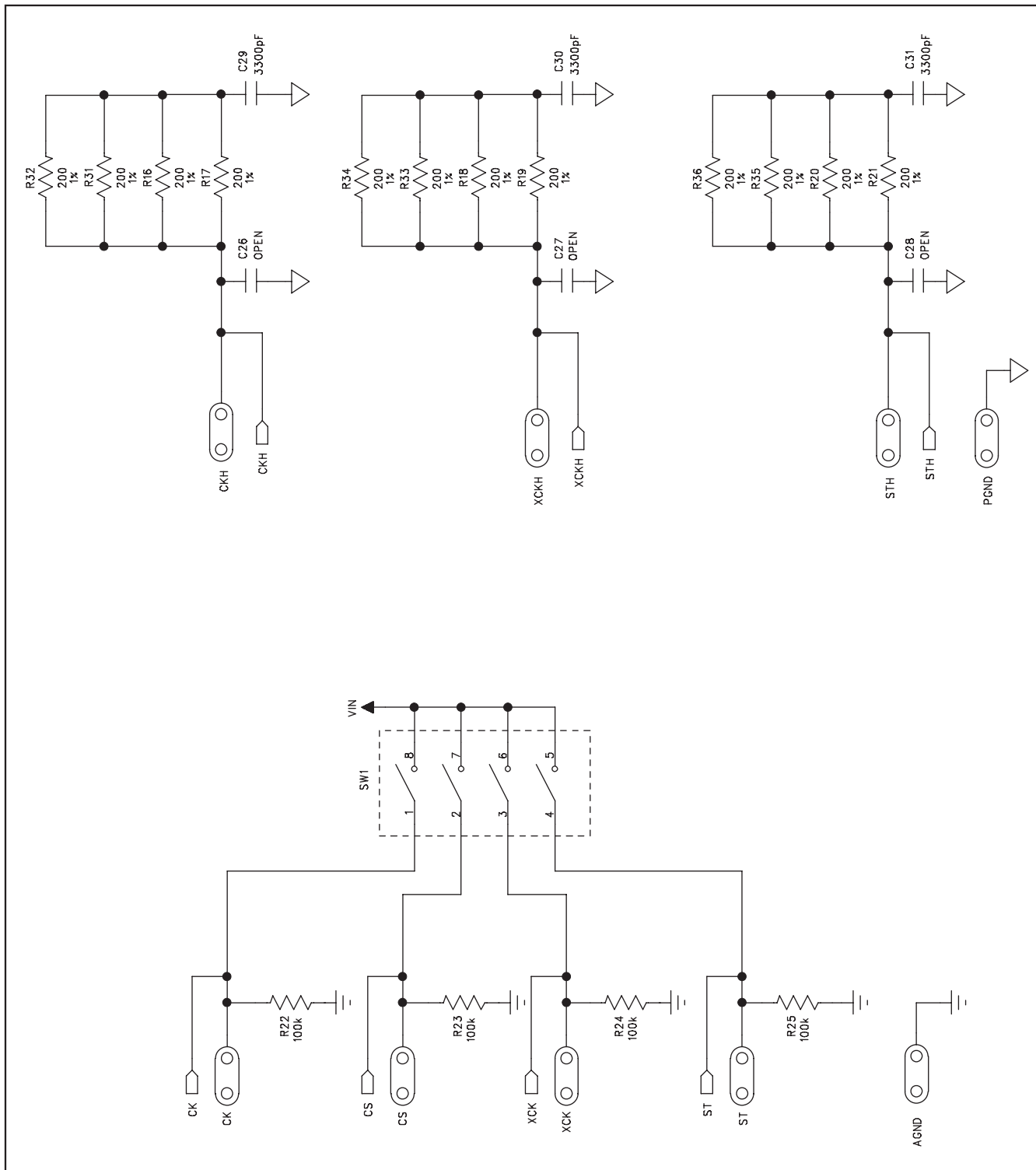

Figure 1b. MAX17103 EV Kit Schematic (Sheet 2 of 2)

MAX17103 Evaluation Kit

Evaluates: MAX17103

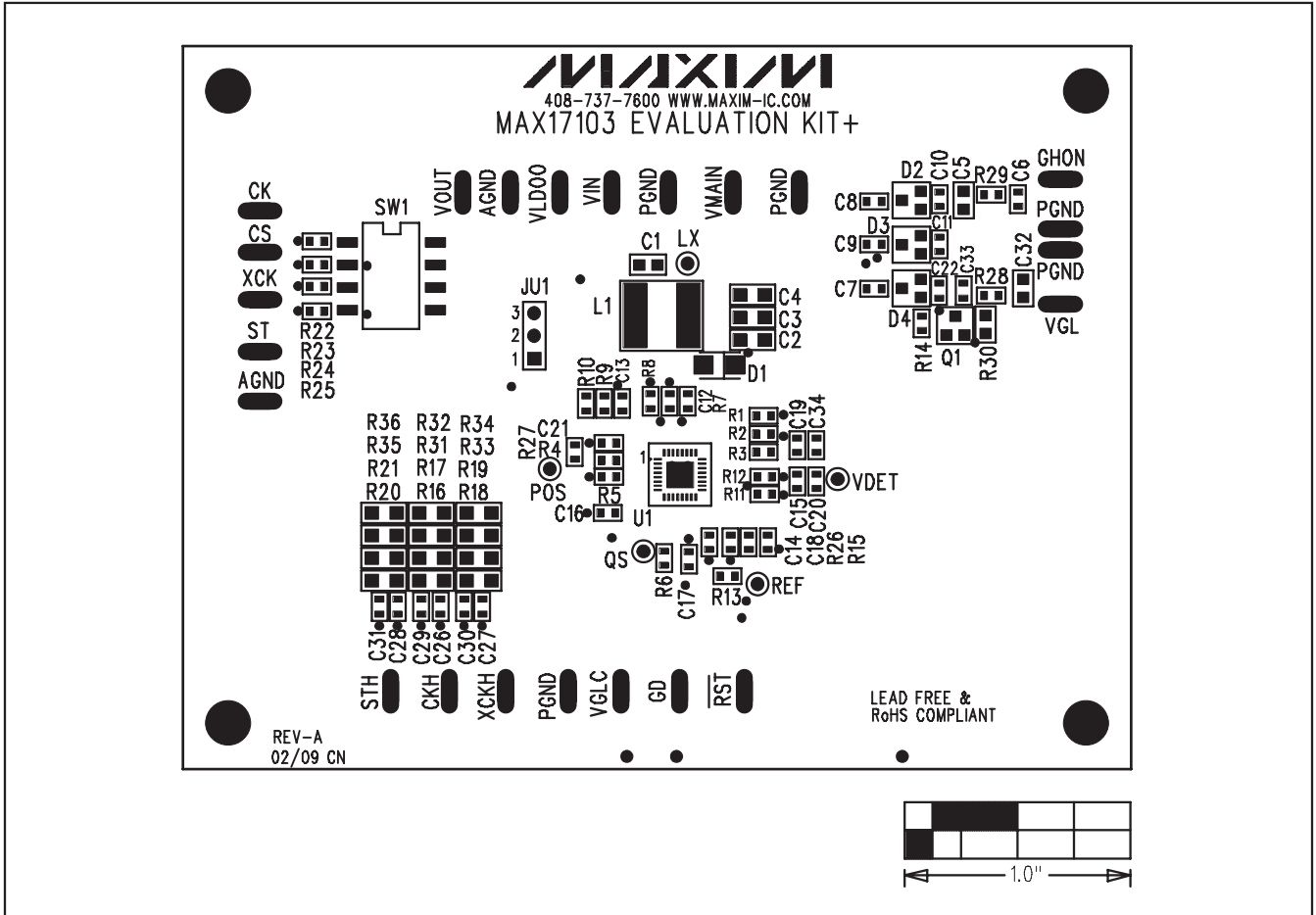

Figure 2. MAX17103 EV Kit Component Placement Guide—Component Side

MAX17103 Evaluation Kit

Evaluates: MAX17103

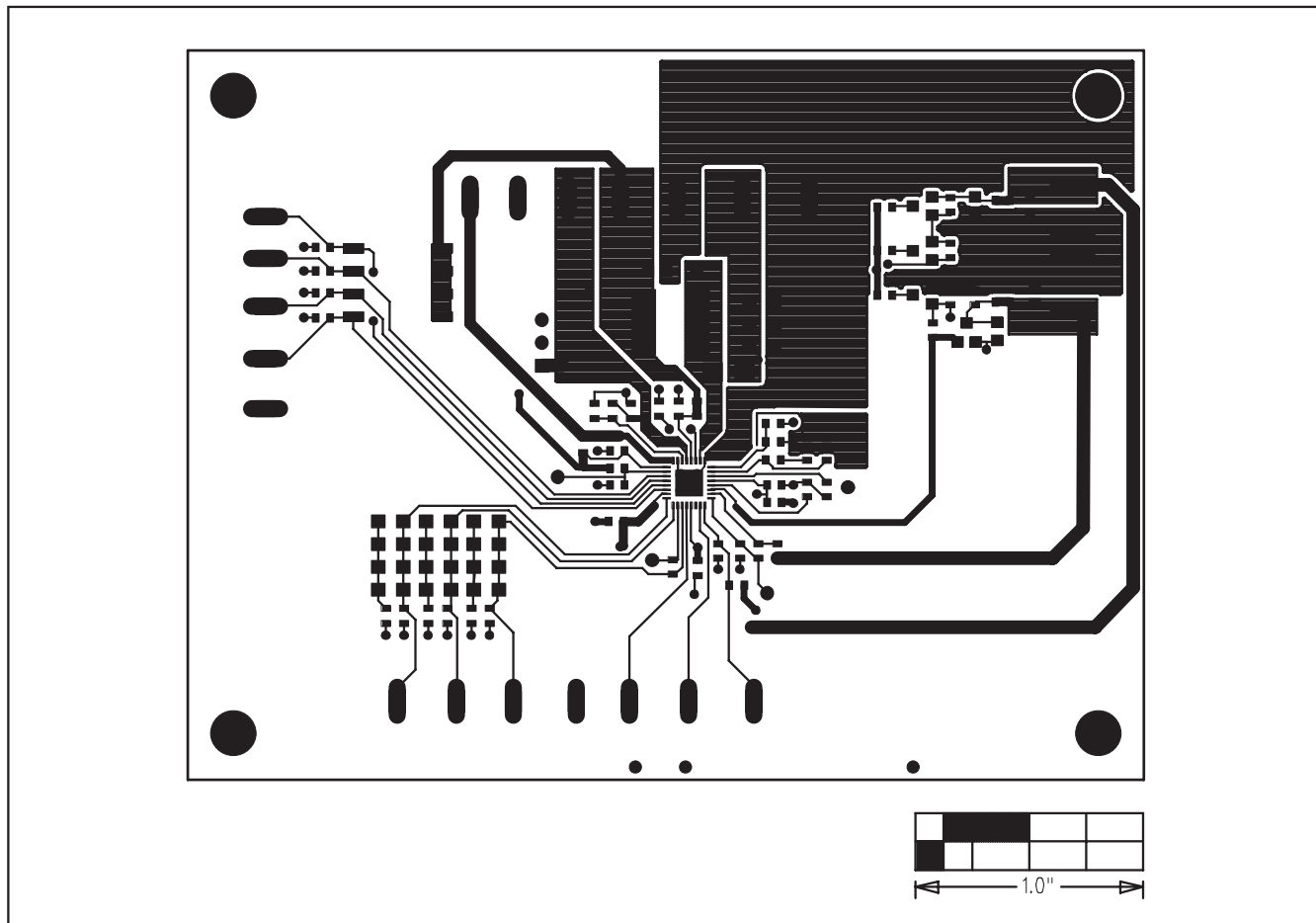

Figure 3. MAX17103 EV Kit PCB Layout—Component Side

MAX17103 Evaluation Kit

Evaluates: MAX17103

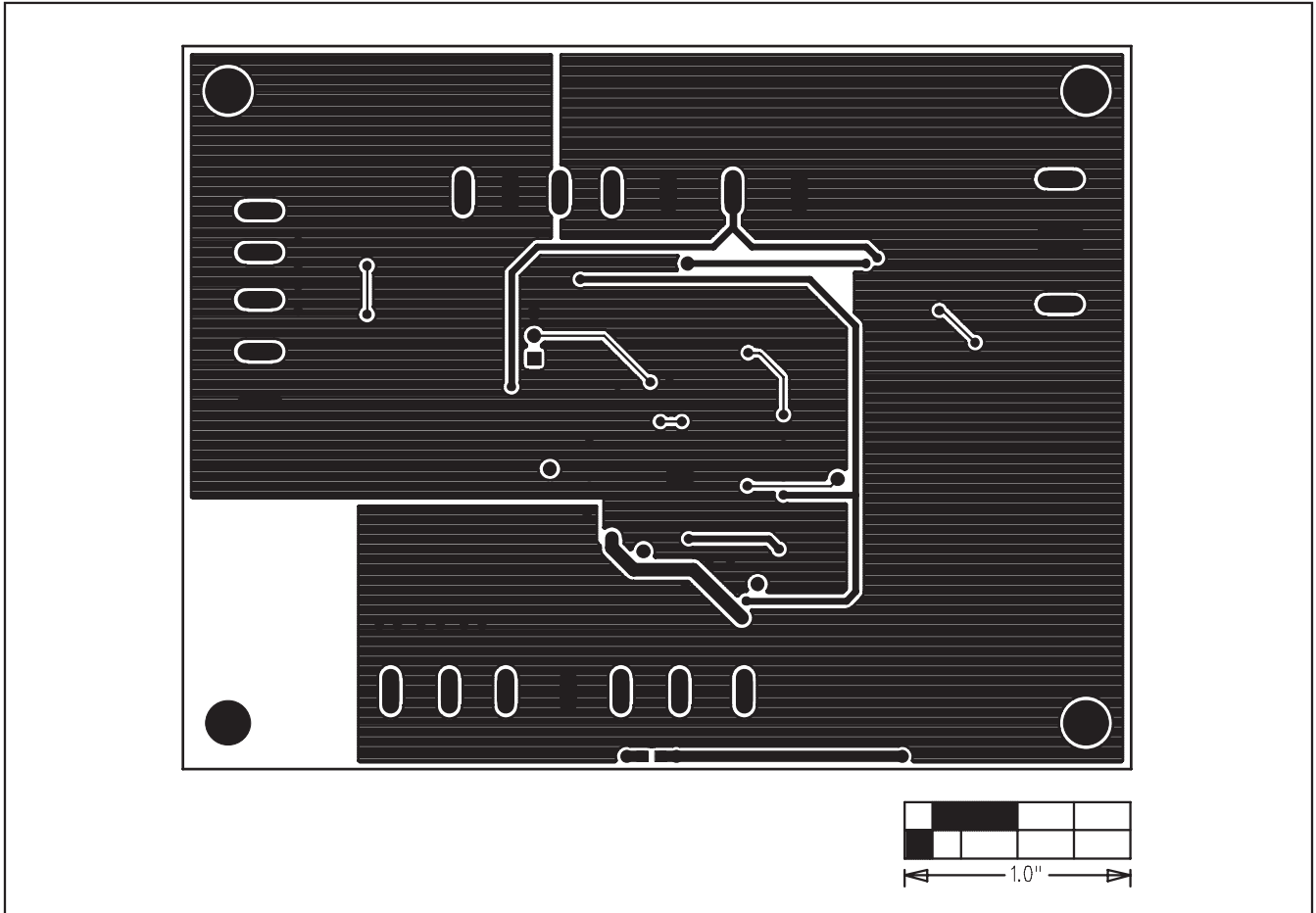

Figure 4. MAX17103 EV Kit PCB Layout—Solder Side

Maxim cannot assume responsibility for use of any circuitry other than circuitry entirely embodied in a Maxim product. No circuit patent licenses are implied. Maxim reserves the right to change the circuitry and specifications without notice at any time.

Maxim Integrated Products, 120 San Gabriel Drive, Sunnyvale, CA 94086 408-737-7600 _____ **9**