



Chipsmall Limited consists of a professional team with an average of over 10 year of expertise in the distribution of electronic components. Based in Hongkong, we have already established firm and mutual-benefit business relationships with customers from,Europe,America and south Asia,supplying obsolete and hard-to-find components to meet their specific needs.

With the principle of “Quality Parts,Customers Priority,Honest Operation,and Considerate Service”,our business mainly focus on the distribution of electronic components. Line cards we deal with include Microchip,ALPS,ROHM,Xilinx,Pulse,ON,Everlight and Freescale. Main products comprise IC,Modules,Potentiometer,IC Socket,Relay,Connector.Our parts cover such applications as commercial,industrial, and automotives areas.

We are looking forward to setting up business relationship with you and hope to provide you with the best service and solution. Let us make a better world for our industry!



Contact us

Tel: +86-755-8981 8866 Fax: +86-755-8427 6832

Email & Skype: info@chipsmall.com Web: www.chipsmall.com

Address: A1208, Overseas Decoration Building, #122 Zhenhua RD., Futian, Shenzhen, China



MAX17129 Evaluation Kit

Evaluates: MAX17129/MAX17149

General Description

The MAX17129 evaluation kit (EV kit) provides a proven design to evaluate the MAX17129 high-efficiency driver for white light-emitting diodes (WLEDs). The EV kit utilizes a step-up DC-DC converter to generate the voltage required to drive up to six strings of 10 surface-mount WLEDs. The EV kit uses a 3V to 26V input supply and can be configured to provide an adjustable 10mA to 45mA full-scale LED current.

Installed on the EV kit is the MAX17129ETE+. Contact the factory for free samples of the pin-compatible MAX17149ETE+.

Features

- ◆ 3V to 26V Input Range
- ◆ Drives Six Strings of 10 WLEDs
- ◆ Full-Scale LED Current Adjustable from 10mA to 45mA
- ◆ Adjustable Switching Frequency of 500kHz or 1MHz
- ◆ Proven PCB Layout
- ◆ Fully Assembled and Tested

Ordering Information appears at end of data sheet.

Component List

DESIGNATION	QTY	DESCRIPTION
C1	1	4.7 μ F \pm 10%, 50V X7R ceramic capacitor (1210) Murata GRM32ER71H475K
C2, C8–C19	0	Not installed, ceramic capacitors (0603)
C3	1	0.1 μ F \pm 10%, 50V X5R ceramic capacitor (0603) Murata GRM188R61H104K
C4	1	1 μ F \pm 10%, 16V X5R ceramic capacitor (0603) Murata GRM188R61C105K
C5	1	2.2 μ F \pm 10%, 50V X7R ceramic capacitor (1210) Murata GRM32ER72A225K
C6, C7	2	1 μ F \pm 10%, 50V X7R ceramic capacitors (0805)
C20	0	Not installed, ceramic capacitor (0805)
D1	1	2A, 40V Schottky diode (M flat) Toshiba CMS11

DESIGNATION	QTY	DESCRIPTION
D2–D61	60	3.5V, 20mA white LEDs
FSEL	0	Not installed, test point
L1	1	10 μ H, 1.2A inductor Sumida CR6D09HPNP-100MC
JU1–JU7	7	3-pin headers
JU8–JU15, JU17	9	2-pin headers
JU16	0	Not installed, 2-pin header—shorted by PC trace
R1	1	500k Ω multiterm potentiometer
R2	1	39k Ω \pm 5% resistor (0603)
R3	1	10k Ω \pm 5% resistor (0603)
R4	1	300k Ω \pm 5% resistor (0603)
R5	1	10 Ω \pm 5% resistor (0603)
R6–R11	0	Not installed, resistors (0603)
U1	1	White LED driver (16 TQFN EP) Maxim MAX17129ETE+
—	16	Shunts
—	1	PCB: MAX17129 EVALUATION KIT+

Component Suppliers

SUPPLIER	PHONE	WEBSITE
Murata Electronics North America, Inc.	770-436-1300	www.murata-northamerica.com
Sumida Corp.	847-545-6700	www.sumida.com
Toshiba America Electronic Components, Inc.	949-623-2900	www.toshiba.com/taec

Note: Indicate that you are using the MAX17129 when contacting these component suppliers.

MAX17129 Evaluation Kit

Evaluates: MAX17129/MAX17149

Quick Start

Required Equipment

- MAX17129 EV kit
- 3V to 26V DC power supply (VIN)

Procedure

The EV kit is fully assembled and tested. Follow the steps below to verify board operation. **Caution: Do not turn on the power supply until all connections are completed.**

- 1) Verify that all jumpers are in their default positions, as shown in Table 1.
- 2) Connect the positive terminal of the power supply to the VIN PCB pad and the negative terminal to the nearest PGND PCB pad on the EV kit.
- 3) Set the VIN power supply to 12V and enable its output.
- 4) Verify that the six strings of WLEDs are turned on.

Table 1. Jumper Descriptions (JU1–JU15, JU17)

JUMPER	SHUNT POSITION	DESCRIPTION
JU1	1-2*	Connects WLED string D2–D11 to the FB1 pin of the device.
	2-3	Connects the FB1 pin of the device to GND, which disables WLED string D2–D11.
	Open	User-supplied WLED string can be connected to the FB1 PCB pad on the EV kit.
JU2	1-2*	Connects WLED string D12–D21 to the FB2 pin of the device.
	2-3	Connects the FB2 pin of the device to GND, which disables WLED string D12–D21.
	Open	User-supplied WLED string can be connected to the FB2 PCB pad on the EV kit.
JU3	1-2*	Connects WLED string D22–D31 to the FB3 pin of the device.
	2-3	Connects the FB3 pin of the device to GND, which disables WLED string D22–D31.
	Open	User-supplied WLED string can be connected to the FB3 PCB pad on the EV kit.
JU4	1-2*	Connects WLED string D32–D41 to the FB4 of the device.
	2-3	Connects the FB4 pin of the device to GND, which disables WLED string D32–D41.
	Open	User-supplied WLED string can be connected to the FB4 PCB pad on the EV kit.
JU5	1-2*	Connects WLED string D42–D51 to the FB5 of the device.
	2-3	Connects the FB5 pin of the device to GND, which disables WLED string D42–D51.
	Open	User-supplied WLED string can be connected to the FB5 PCB pad on the EV kit.
JU6	1-2*	Connects WLED string D52–D61 to the FB6 of the device.
	2-3	Connects the FB6 pin of the device to GND, which disables WLED string D52–D61.
	Open	User-supplied WLED string can be connected to the FB6 PCB pad on the EV kit.
JU7	1-2	Connects the FSEL pin of the device to VCC, which sets the switching frequency to 500kHz.
	2-3*	Connects the FSEL pin of the device to GND, which sets the switching frequency to 1MHz.
JU8	1-2*	Connects the EN pin of the device through a pullup resistor to VIN to enable the device.
	Open	Allows the user to externally drive EN.
JU9	1-2*	Connects the output voltage of the device to the six strings of WLEDs.
	Open	Disconnects the output voltage of the device from the six strings of WLEDs D2–D61.
JU10	1-2	Removes WLEDs D59, D60, and D61 from the string of WLEDs going to the FB6 pin of the device. When installing the MAX17149, the shunt is only allowed in this position.
	Open*	Connects WLEDs D59, D60, and D61 to the string of WLEDs going to the FB6 pin of the device.
JU11	1-2	Removes WLEDs D49, D50, and D51 from the string of WLEDs going to the FB5 pin of the device. When installing the MAX17149, the shunt is only allowed in this position.
	Open*	Connects WLEDs D49, D50, and D51 to the string of WLEDs going to the FB5 pin of the device.
JU12	1-2	Removes WLEDs D39, D40, and D41 from the string of WLEDs going to the FB4 pin of the device. When installing the MAX17149, the shunt is only allowed in this position.
	Open*	Connects WLEDs D39, D40, and D41 to the string of WLEDs going to the FB4 pin of the device.
JU13	1-2	Removes WLEDs D29, D30, and D31 from the string of WLEDs going to the FB3 pin of the device. When installing the MAX17149, the shunt is only allowed in this position.
	Open*	Connects WLEDs D29, D30, and D31 to the string of WLEDs going to the FB3 pin of the device.

MAX17129 Evaluation Kit

Evaluates: MAX17129/MAX17149

Table 1. Jumper Descriptions (JU1–JU15, JU17) (continued)

JUMPER	SHUNT POSITION	DESCRIPTION
JU14	1-2	Removes WLEDs D19, D20, and D21 from the string of WLEDs going to the FB2 pin of the device. When installing the MAX17149, the shunt is only allowed in this position.
	Open*	Connects WLEDs D19, D20, and D21 to the string of WLEDs going to the FB2 pin of the device.
JU15	1-2	Removes WLEDs D9, D10, and D11 from the string of WLEDs going to the FB1 pin of the device. When installing the MAX17149, the shunt is only allowed in this position.
	Open*	Connects WLEDs D9, D10, and D11 to the string of WLEDs going to the FB1 pin of the device.
JU17	1-2	Connects the IN pin and VCC pin of the device together. The voltage applied at the VIN PCB pad of the EV kit must be between 3V to 5.5V.
	Open*	Disconnects the IN pin and VCC pin of the device together. The voltage applied at the VIN PCB pad of the EV kit must be between 6V to 26V.

*Default position.

Detailed Description of Hardware

The MAX17129 EV kit operates on a 3V to 26V wide-input voltage range and provides an adjustable 10mA to 45mA full-scale LED current. The EV kit utilizes a step-up DC-DC converter to generate the voltage required to drive up to six strings of 10 surface-mount WLEDs.

Input Supply

When jumper JU17 doesn't have a shunt installed, the input supply range is 6V to 26V at the VIN PCB pad on the EV kit. If JU17 is installed, the input supply range changes to 3V to 5.5V.

White LED String Configuration

As configured, the EV kit is assembled with six strings of 10 WLEDs. Each string has an associated 3-pin header (JU1–JU6) and feedback pin (FB1–FB6). The function of the 3-pin jumpers is summarized in Table 1. To evaluate the EV kit with off-board WLED strings, see the *Off-Board White LED String Configuration* section.

Off-Board White LED String Configuration

The EV kit can also be used to drive off-board WLED strings. To evaluate external WLED strings, reconfigure shunts from jumpers JU1–JU6 (see Table 1). Removing the shunt completely disconnects the on-board WLED strings between the output and feedback pins, allowing for the connection of external WLED strings. For each external WLED string, connect the cathode terminal of the string to the corresponding feedback PCB pad (FB1–FB6) on the EV kit and connect the anode terminal of the string to the VOUT PCB pad on the EV kit. Once the external WLED strings are connected between the VOUT PCB pad and the FB_ pins, the EV kit can be evaluated in the same manner as the on-board WLED strings. Evaluating more than 10 WLEDs per string could require component changes. Refer to the MAX17129/MAX17149 IC data sheet for component selections.

Enable (EN)

The device is in normal operation when a shunt is installed on jumper JU8, which drives the EN pin high. To place the device into shutdown, remove the shunt from JU8.

Brightness Control (BRT)

To control the brightness of the WLEDs, apply a PWM signal between 0.1kHz and 25kHz on the BRT PCB pad on the EV kit.

LED String Capacitance

In some LCD panel applications, a 0.1µF (typ) capacitor (CLED) is placed in parallel with each WLED string to improve ESD immunity. As such, the EV kit provides a capacitor footprint across each WLED string for optional CLED.

Full-Scale LED Current-Adjustment (ISET)

The EV kit uses resistors R1 and R2 to set the full-scale LED current (ILED_FS). The resistance from the ISET pin of the device to GND controls the full-scale current in each WLED string according to the following equation:

$$I_{LED_FS} = \frac{20mA \times 100k\Omega}{R1 + R2}$$

where R1 is a 500kΩ potentiometer and R2 is a 39kΩ resistor.

Switching-Frequency Selection (FSEL)

The EV kit can operate from 1MHz or 500kHz using jumper JU7. Place a shunt on JU7 in the 1-2 position and the switching frequency set to 500kHz. When JU7 is the 2-3 position, 1MHz switching frequency is achieved.

MAX17129 Evaluation Kit

Evaluates: MAX17129/MAX17149

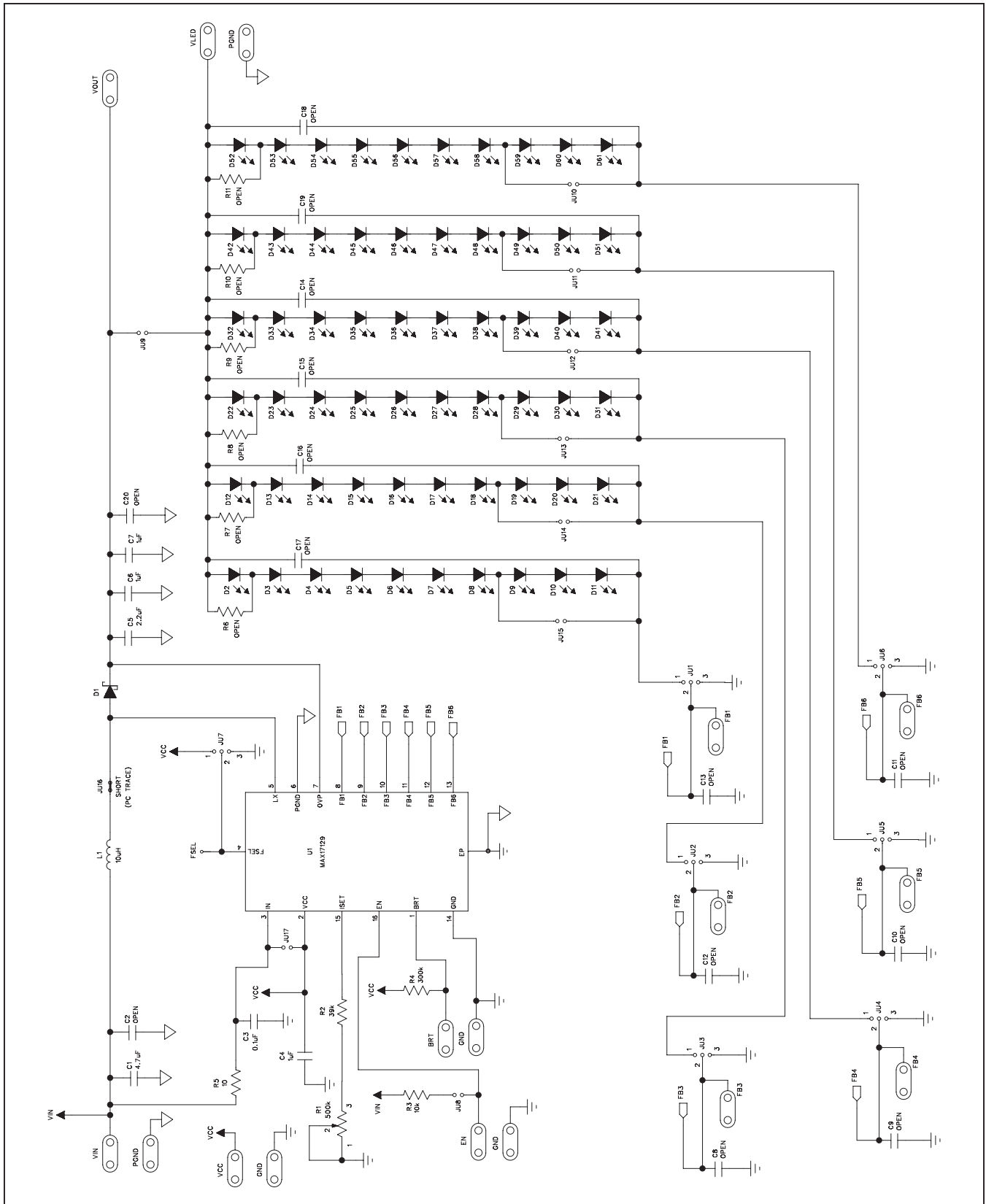

Figure 1. MAX17129 EV Kit Schematic

MAX17129 Evaluation Kit

Evaluates: MAX17129/MAX17149

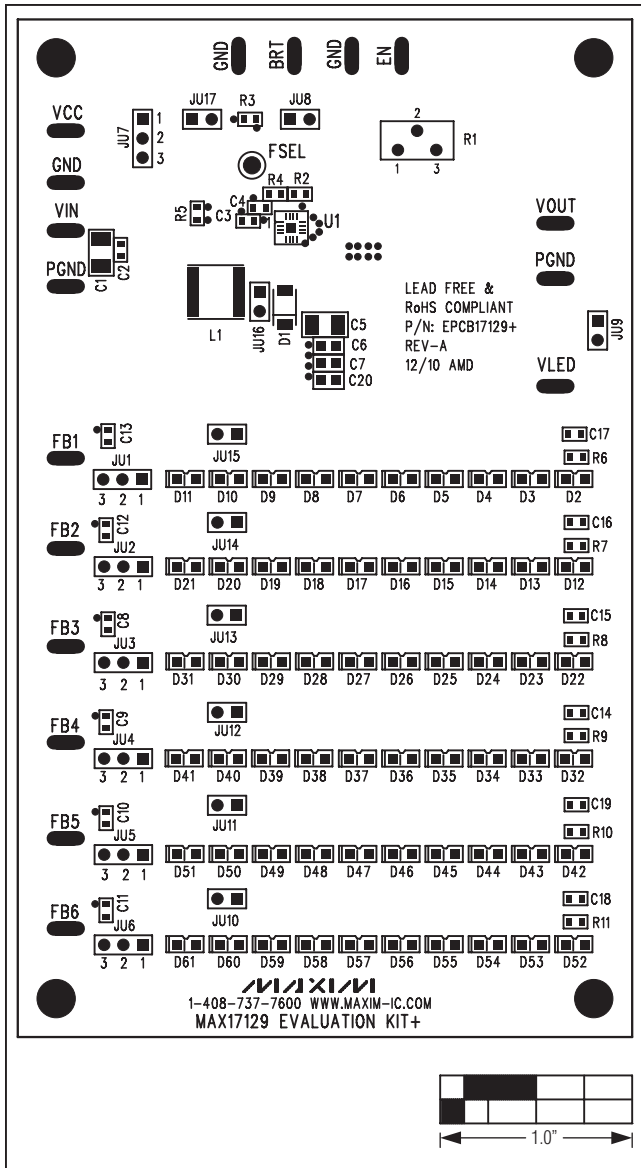

Figure 2. MAX17129 EV Kit Component Placement Guide—Component Side

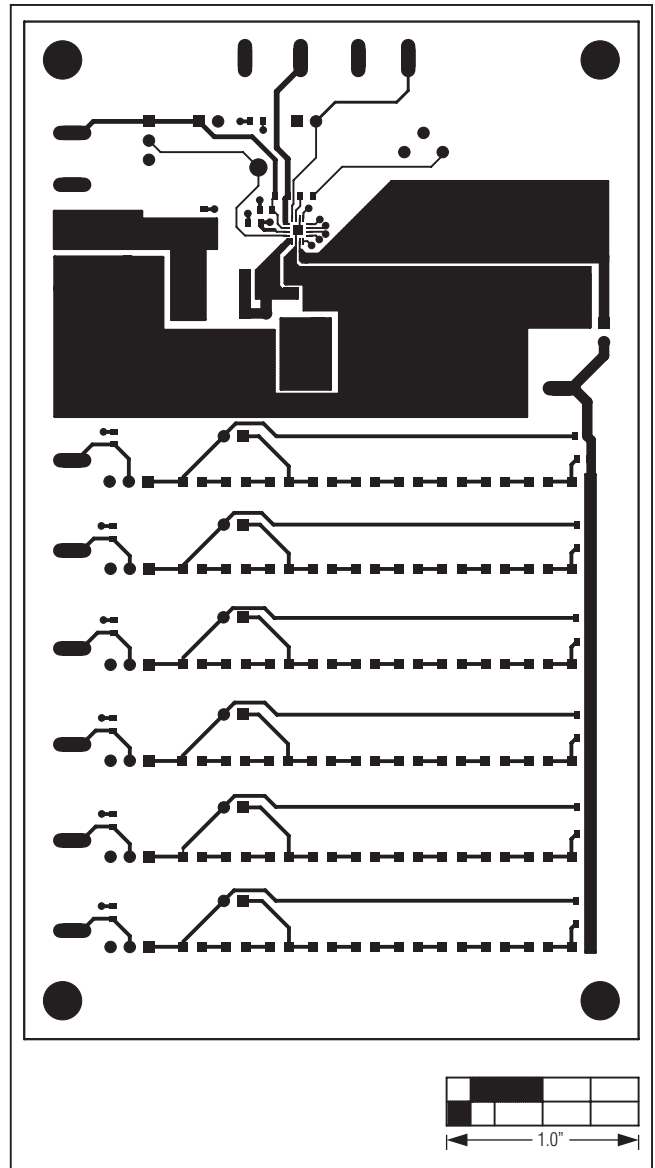

Figure 3. MAX17129 EV Kit PCB Layout—Component Side

MAX17129 Evaluation Kit

Evaluates: MAX17129/MAX17149

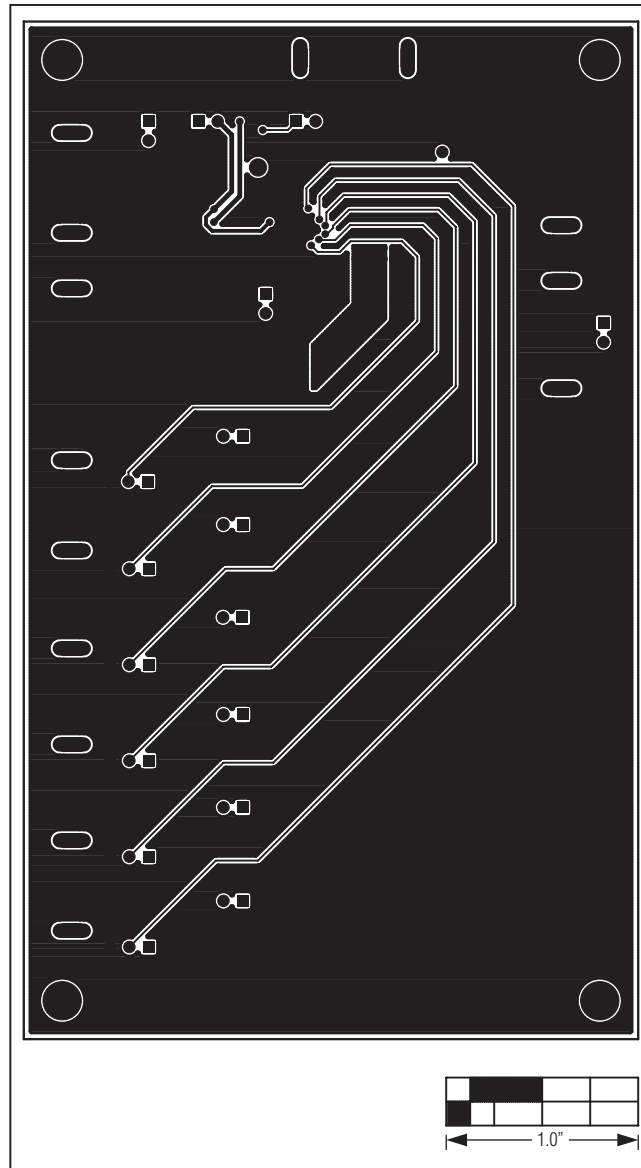

Figure 4. MAX17129 EV Kit PCB Layout—Solder Side

MAX17129 Evaluation Kit

Evaluates: MAX17129/MAX17149

Ordering Information

PART	TYPE
MAX17129EVKIT+	EV Kit

+Denotes lead(Pb)-free and RoHS compliant.

MAX17129 Evaluation Kit

Evaluates: MAX17129/MAX17149

Revision History

REVISION NUMBER	REVISION DATE	DESCRIPTION	PAGES CHANGED
0	2/11	Initial release	—

Maxim cannot assume responsibility for use of any circuitry other than circuitry entirely embodied in a Maxim product. No circuit patent licenses are implied. Maxim reserves the right to change the circuitry and specifications without notice at any time.

Maxim Integrated Products, 120 San Gabriel Drive, Sunnyvale, CA 94086 408-737-7600 _____ 8