



Chipsmall Limited consists of a professional team with an average of over 10 year of expertise in the distribution of electronic components. Based in Hongkong, we have already established firm and mutual-benefit business relationships with customers from,Europe,America and south Asia,supplying obsolete and hard-to-find components to meet their specific needs.

With the principle of “Quality Parts,Customers Priority,Honest Operation,and Considerate Service”,our business mainly focus on the distribution of electronic components. Line cards we deal with include Microchip,ALPS,ROHM,Xilinx,Pulse,ON,Everlight and Freescale. Main products comprise IC,Modules,Potentiometer,IC Socket,Relay,Connector.Our parts cover such applications as commercial,industrial, and automotives areas.

We are looking forward to setting up business relationship with you and hope to provide you with the best service and solution. Let us make a better world for our industry!



Contact us

Tel: +86-755-8981 8866 Fax: +86-755-8427 6832

Email & Skype: info@chipsmall.com Web: www.chipsmall.com

Address: A1208, Overseas Decoration Building, #122 Zhenhua RD., Futian, Shenzhen, China



MAX17243 Evaluation Kit with Preset 5V/3A Output

Evaluates: MAX17243

General Description

The MAX17243 evaluation kit (EV kit) demonstrates the MAX17243 high-voltage, current-mode step-down converters with low operating current. The EV kit operates over a wide 5.6V to 36V input range and the output is set for 5V at 3A.

The EV kit comes with the MAX17243ATPA/V+ installed.

Features

- Wide 5.6V to 36V Input Supply Range
- Forced-PWM or Skip-Mode Operation
- Programmable Switching Frequency (2.2MHz Default)
- Power-Good Output
- 4-Layer 2oz Copper
- Proven PCB Layout
- Fully Assembled and Tested

Ordering Information appears at end of data sheet.

Quick Start

Required Equipment

- MAX17243EV kit
- 14V, 2A DC power supply
- Electronic load capable of 3A
- Digital voltmeter (DVM)

Procedure

The EV kit is fully assembled and tested. Follow the steps below to verify board operation. **Caution: Do not turn on supplies until all connections are made.**

- 1) Verify that jumpers JU1–JU4 are in their default positions, as shown in Tables 1–4.
- 2) Connect the power supply between the VINSUPSW and nearest PGND test points.
- 3) Connect the 3A electronic load between the OUT and nearest PGND test points.
- 4) Connect the DVM between the OUT and nearest PGND test points.
- 5) Turn on the power supply.
- 6) Enable the electronic load.
- 7) Verify that the voltage at the OUT test point is approximately 5V.

Table 1. EN Configuration (JU1)

SHUNT POSITION	EN PIN	MODE
1-2*	Connected to SUP	Normal Operation
2-3	Connected to PGND	Shutdown Mode

*Default position.

Table 2. Operating-Mode and Frequency Control (JU2)

SHUNT POSITION	FSYNC PIN	MODE
1-2*	Connected to BIAS	Forced-PWM mode
2-3	Connected to AGND	Skip mode
Not installed**	Connected to an external clock	Forced-PWM mode (device syncs to an external clock)

*Default position.

Table 3. Spread Spectrum (JU3)

SHUNT POSITION	SPS PIN	MODE
1-2*	Connected to BIAS	Spread-Spectrum Enabled
2-3	Connected to AGND	Spread-Spectrum Disabled

*Default position.

Table 4. PGOOD (JU4)

SHUNT POSITION	MODE
Installed*	PGOOD pulled high to BIAS
Not installed	PGOOD unconnected

*Default position.

Detailed Description of Hardware

The MAX17243EV kit demonstrates the MAX17243 high-voltage, high-frequency, step-down converter with low operating current. The EV kit operates over a wide 5.6V to 36V input range and the output is set for 5V at 3A. For 24V to 36V operation forced air cooling must be used. Consider thermal and switching efficiency when designing for operation in this input voltage range.

Enable (EN)

Place a shunt in the 1-2 position on JU1 for normal operation. To place the device into shutdown mode, move the shunt on JU1 to the 2-3 position.

Synchronization Input (FSYNC)

The EV kit features JU2 to control the synchronization input (FSYNC). The device synchronizes to an external signal applied to FSYNC. Connect FSYNC to AGND to enable skip-mode operation. Connect to BIAS or to an external clock to enable fixed-frequency forced-PWM mode operation.

To use an external clock, uninstall the shunt on JU2 and apply the signal at the FSYNC test point and AGND. The external clock frequency at FSYNC can be higher or lower than the internal clock by 20%. Ensure that the duty cycle of the external clock used has a minimum 100ns pulse width.

Spread-Spectrum Option (SPS)

The EV kit provides JU3 that allows SPS to be pulled high (BIAS) or pulled low (AGND). Connect SPS high to enable spread spectrum where the operating frequency is varied $\pm 3\%$ centered on FOSC. Connect SPS low to disable the spread-spectrum feature.

Setting the Switching Frequency (FOSC)

The EV kit switches at 2.2MHz by default, and the switching frequency is set by a resistor, R_{FOSC} (R4), connected from FOSC to AGND. Refer to TOC08 in the *Typical Operating Characteristics* section of the MAX17243 IC data sheet for the correct R_{FOSC} (R4) value.

Power-Good Output (PGOOD)

The EV kit provides a PGOOD test point to monitor the status of the device output. PGOOD asserts when V_{OUT} rises above 95% of its regulation voltage. PGOOD deasserts when V_{OUT} drops below 92.5% of its regulation voltage. R5 pulls PGOOD up to BIAS with respect to AGND.

Output

Resistor R6 connects FB to BIAS for a fixed +5V (EV kit default output) or a fixed +3.3V output voltage. To set the output to other voltages between 1V and 10V, connect a resistive divider from output (OUT) to FB to AGND. Use the following equation to determine the R7 and R8 of the resistive divider network:

$$R7 = R8 \times \left(\frac{V_{OUT}}{V_{FB}} - 1 \right)$$

where $V_{FB} = 1V$ and $R8$ is $\leq 500k\Omega$.

Operation at 400kHz Switching Frequency

For 400kHz switching frequency, the following components must be changed to:

- R4 = 73.2k Ω
- L1 = 6.8 μ H (recommend Coilcraft XAL5050-682MEB)
- R1 = 16.5k Ω
- C10 = 4,700pF
- C11 = 6.8pF

Additional capacitance on C7 and C8 may be needed, depending on transient performance.

Component Suppliers

SUPPLIER	WEBSITE
Coilcraft Inc.	www.coilcraft.com
Murata Americas	www.murata.com
Panasonic Corp.	www.panasonic.com
Würth Elektronik GmbH & Co. KG	www.we-online.com
TDK Corporation	www.tdk.com

Note: Indicate that you are using the MAX17243 when contacting these component suppliers.

Component Information, PCB Layout, and Schematics

See the following links for component information, PCB layout diagrams, and schematics.

- [MAX17243 EV BOM](#)
- [MAX17243 EV PCB Layout](#)
- [MAX17243 EV Schematic](#)
- [MAX17243 EV Minimal Component Schematic](#)

Ordering Information

PART	TYPE
MAX17243EVKIT#	EV Kit

#Denotes RoHS compliant.

Revision History

REVISION NUMBER	REVISION DATE	DESCRIPTION	PAGES CHANGED
0	8/16	Initial release	—

For pricing, delivery, and ordering information, please contact Maxim Direct at 1-888-629-4642, or visit Maxim Integrated's website at www.maximintegrated.com.

Maxim Integrated cannot assume responsibility for use of any circuitry other than circuitry entirely embodied in a Maxim Integrated product. No circuit patent licenses are implied. Maxim Integrated reserves the right to change the circuitry and specifications without notice at any time.

MAX17243EVKIT#: Rev A				
Parent	Component	QTY	Remarks	Manufacturer
Number	Description	Per	(Reference Designators)	Part Number
MAX17243EVKIT#	47uF, 50V aluminum electrolytic capacitor (E)	1	C1	Panasonic EEE-FK1H470P
	4.7uF 10%, 50V X7R ceramic capacitor (1210)	1	C2	Murata GCM32ER71H475KA55L
	0.1uF 10%, 50V X7R ceramic capacitor (0603)	2	C3, C5	Murata GCM188R71H104KA57D
	2.2uF 10%, 50V X7R ceramic capacitor (0805)	1	C4	TDK C2012X7R1H225K125AC
	0.1uF 10%, 50V X7R ceramic capacitor (0402)	1	C6	TDK CGA2B3X7R1H104K050BB
	22uF 10%, 10V X7R ceramic capacitors (1210)	2	C7, C8	Murata GCM32ER71A226KE12L
	2.2uF 10%, 10V X7R ceramic capacitor (0603)	1	C9	Murata GRM188R71A225K
	1000pF 10% 50V X7R ceramic capacitor (0402)	1	C10	Murata GRM155R71H102K
	10pF 5% 50V C0G ceramic capacitor (0402)	1	C11	Murata GRM1555C1H100J
	Multipurpose test points, red	4	PGOOD	Keystone 5010
	Multipurpose test points, black	3	PGND, PGND, AGND	Keystone 5011
	3 pin header, 2.54MM, Comes in 36-40 Pin Strips (CUT TO FIT)	3	JU1-JU3	SULLINS PEC36SAAN
	2 pin header, 2.54MM, Comes in 36-40 Pin Strips (CUT TO FIT)	1	JU4	SULLINS PEC36SAAN
	2.2uH, 9.2A Shielded Power inductor	1	L1	Coilcraft XAL5030-222MEB
	20.0k ohms 1% resistor (0402)	1	R1	Any
	0 ohms 5% resistor (0402)	3	R2, R6, R11	Any
	100k ohms 5% resistor (0402)	1	R3	Any
	12.1k ohms 1% resistor (0402)	1	R4	Any
	10k ohms 5% resistor (0402)	1	R5	Any
	0 ohms 5% resistor (1210)	1	R9	Any
	220kHz to 2.2MHz, 3A Fully Integrated Step-down Converter (20 TQFN-EP)	1	U1	Maxim MAX17243ETPA+
	Shunts	4		Kycon SX1100-B
	PC board: MAX17243 EVALUATION KIT	1	2 oz.	
	Not installed, ceramic capacitor (0603)	0	C13	
	Not installed, ceramic capacitor (0402)	0	C12, C14, C15, C16, C17	
	Not Installed, Ferrite Bead (1206)	0	L2	
	Not installed, resistor (0402)	0	R7, R8, R10	

MAX17243 EVKIT
 1-888-629-4642
 www.maximintegrated.com

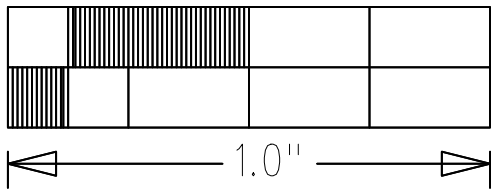
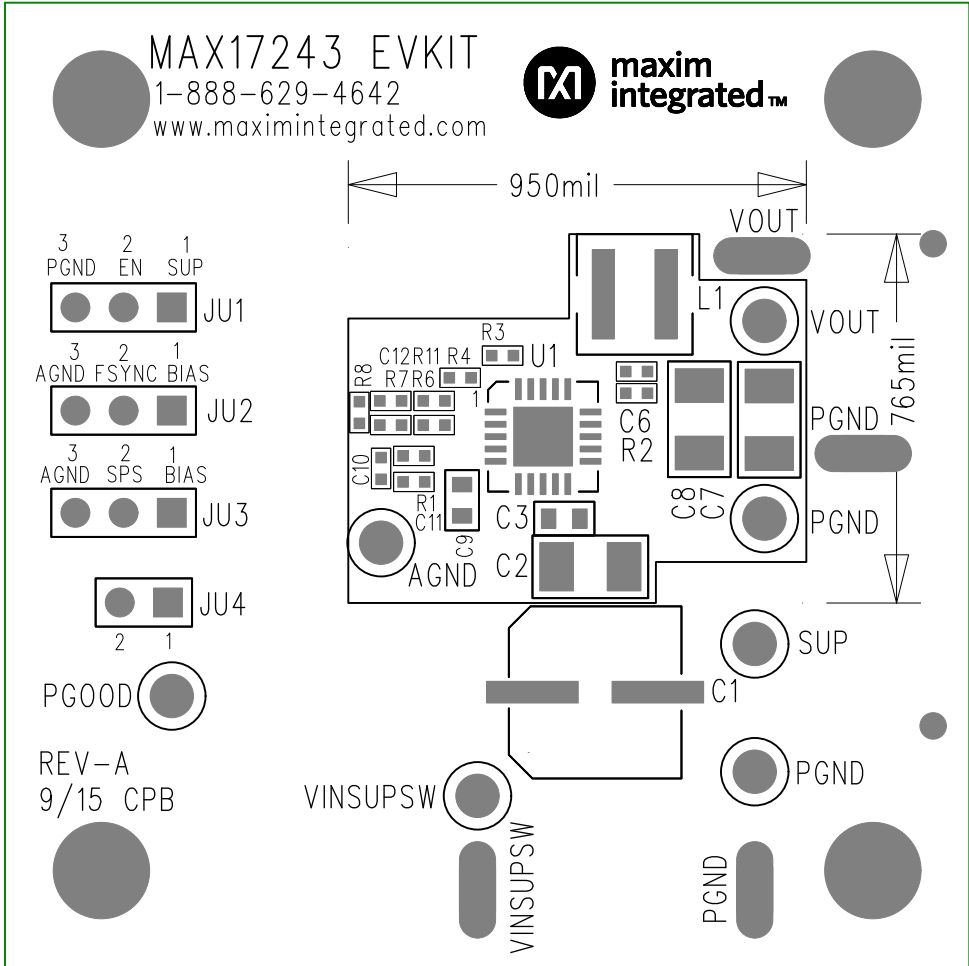

TOP SILKSCREEN

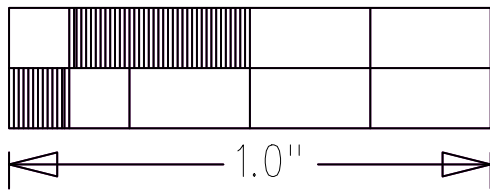
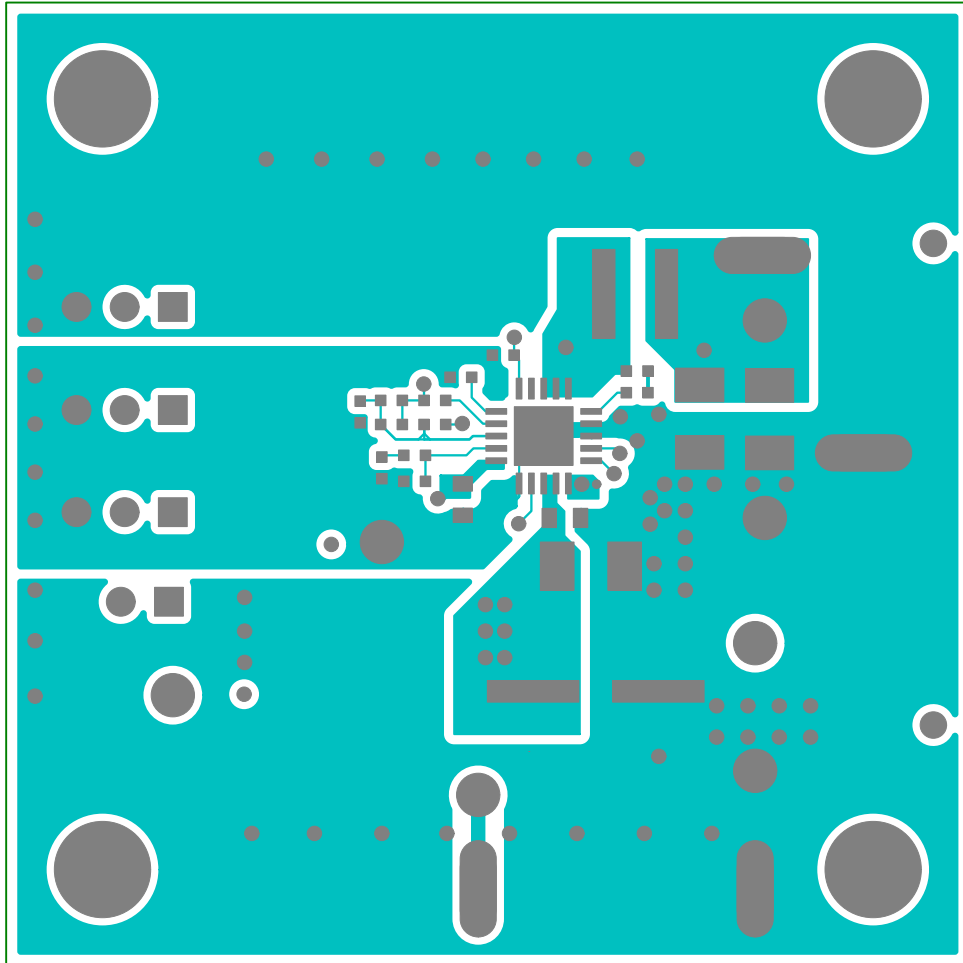

COMPONENT SIDE

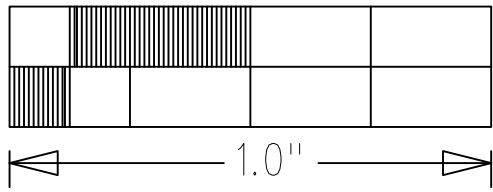
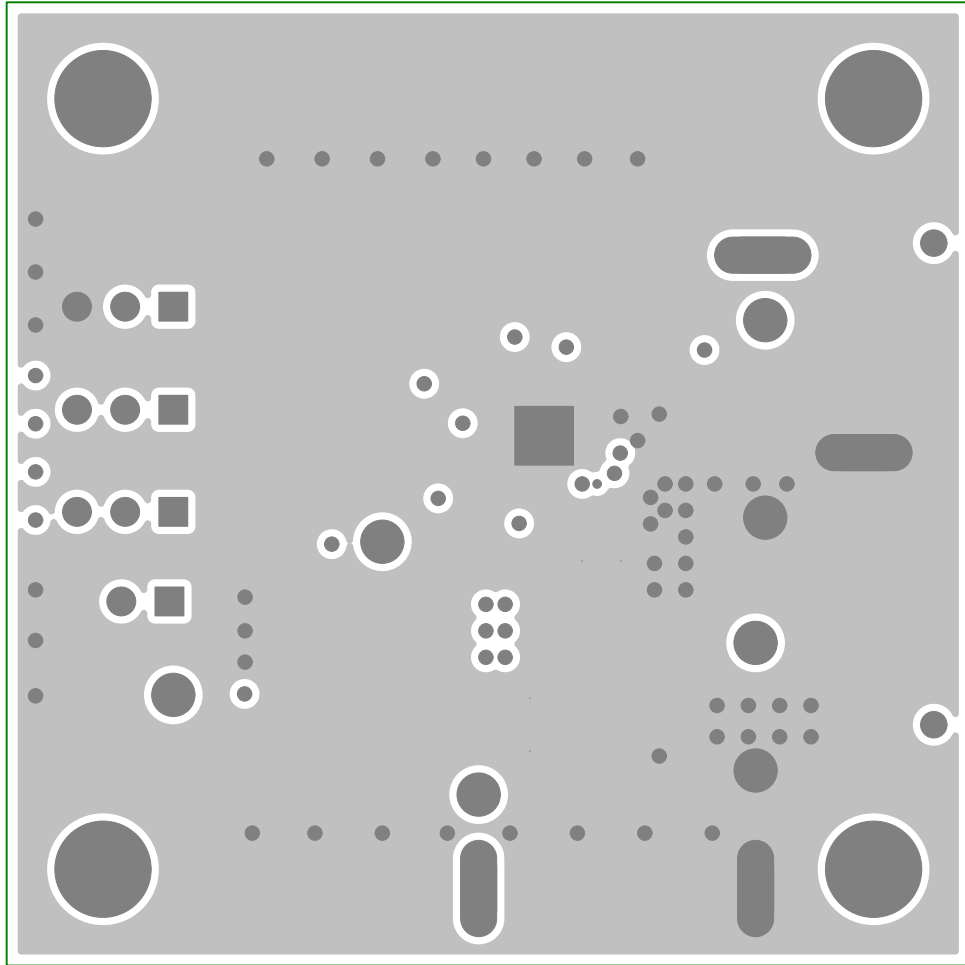

LAYER 2 PGND

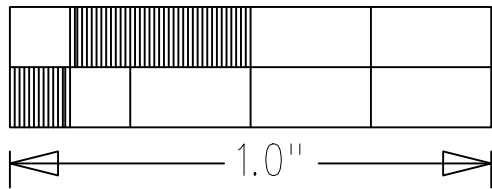
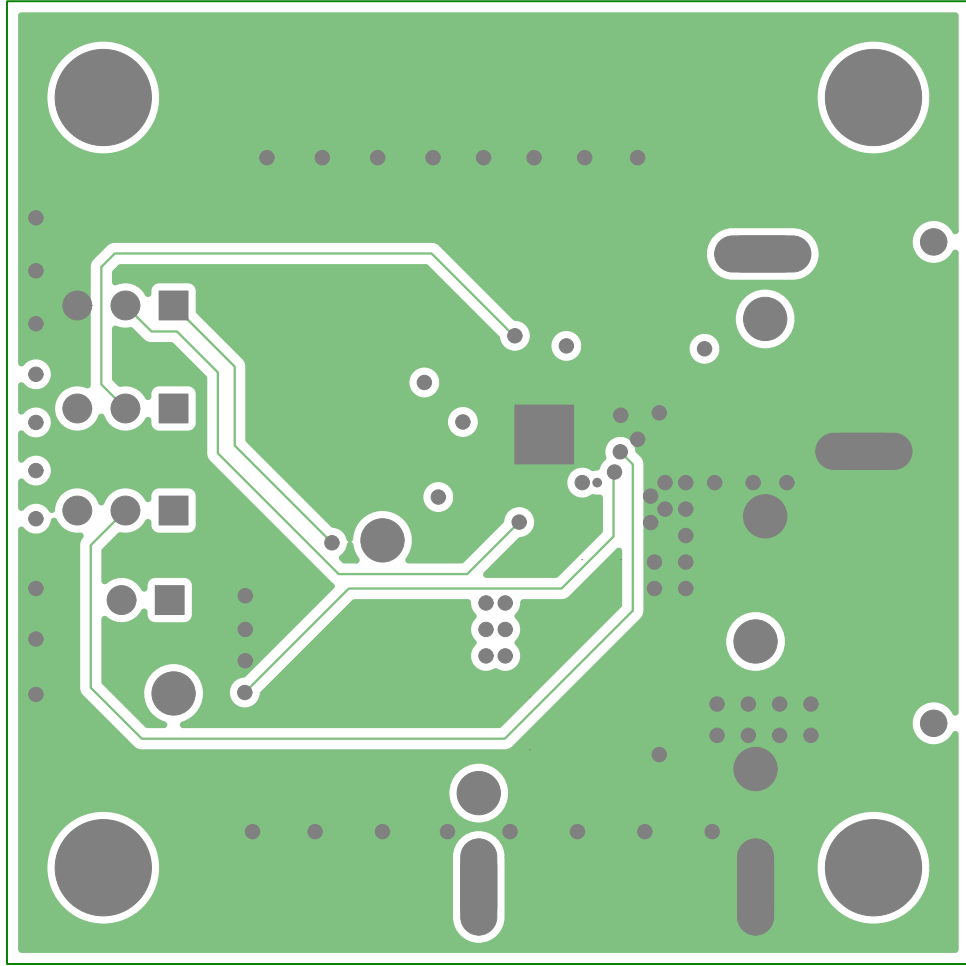

LAYER 3 SIGNAL, PGND

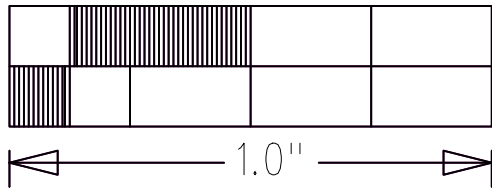
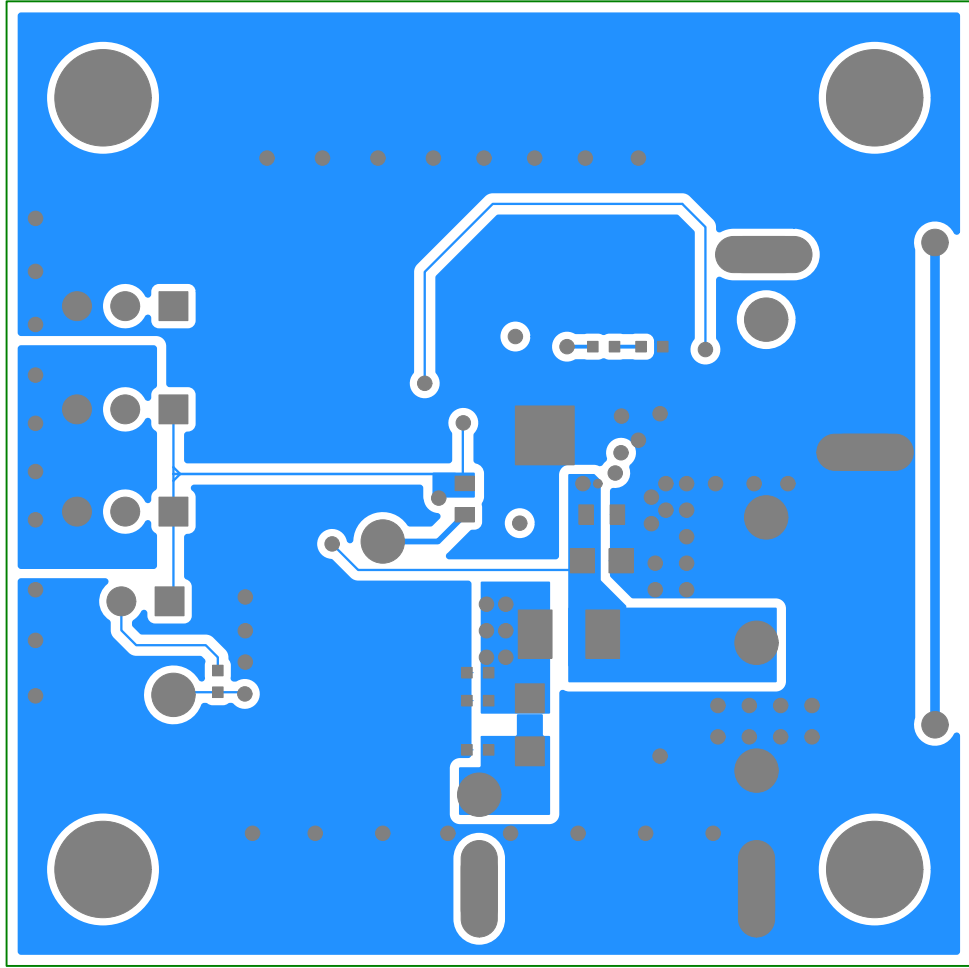

SOLDER SIDE

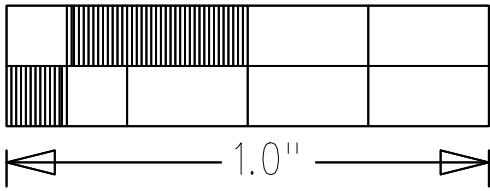
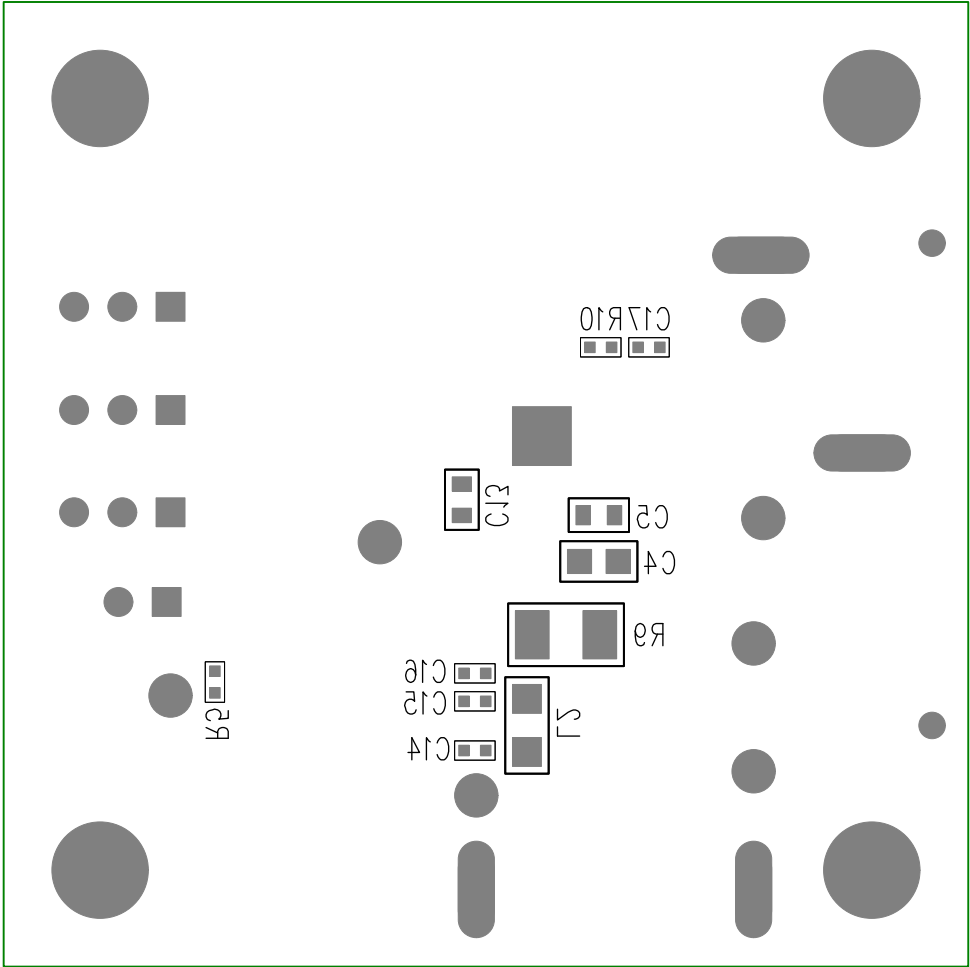

BOTTOM SILKSCREEN

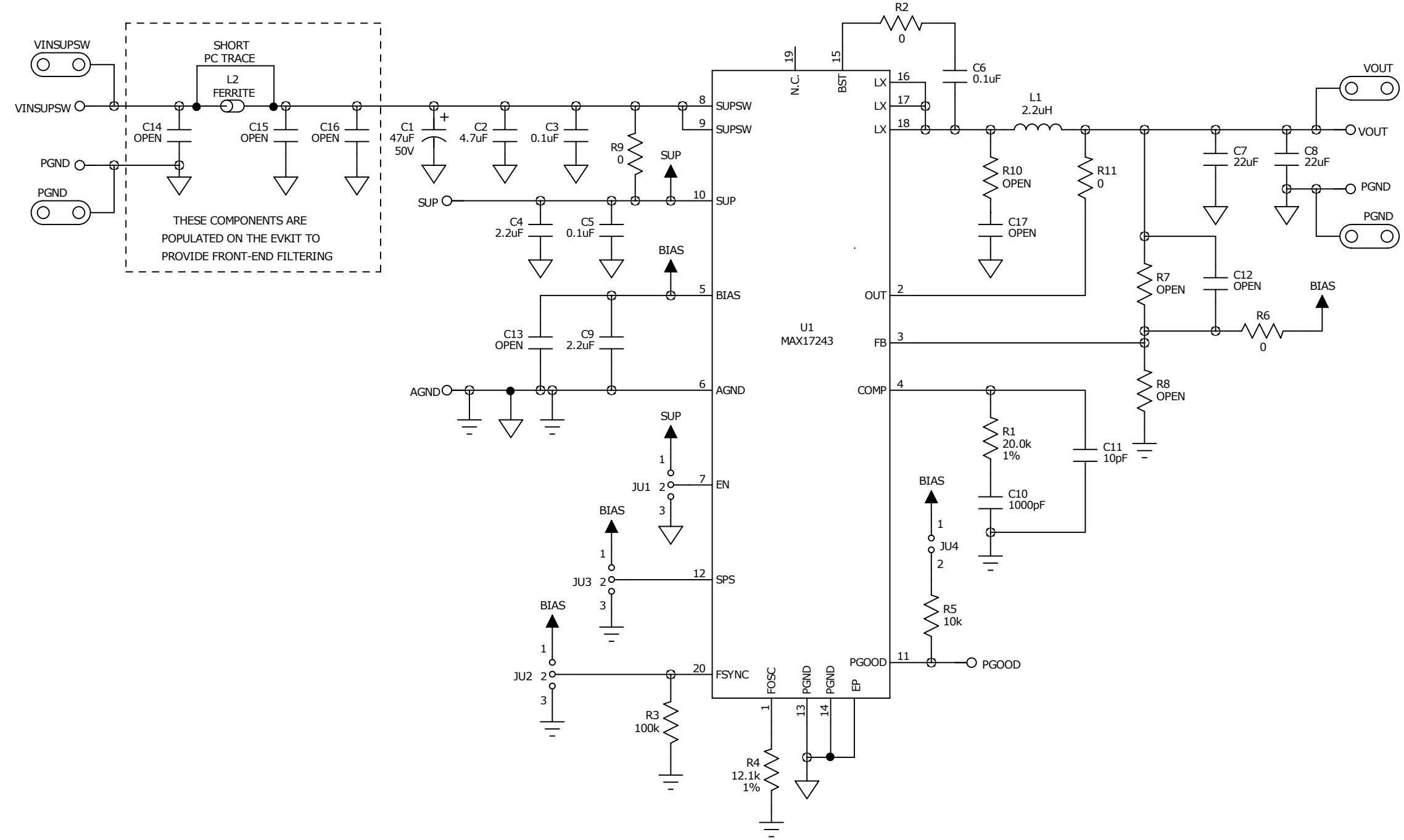

SCHEMATIC

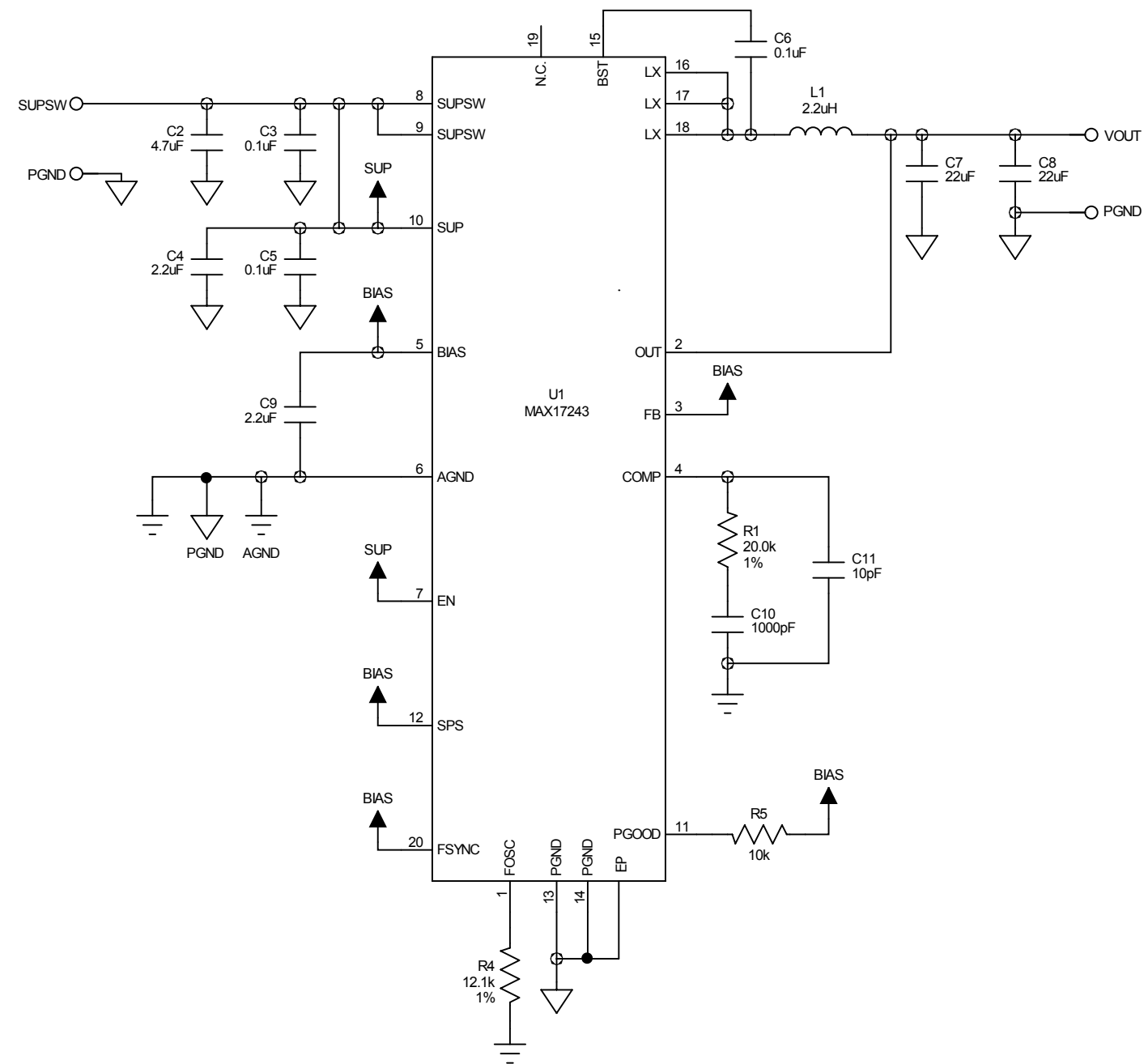

MINIMAL COMPONENT SCHEMATIC