



Chipsmall Limited consists of a professional team with an average of over 10 year of expertise in the distribution of electronic components. Based in Hongkong, we have already established firm and mutual-benefit business relationships with customers from,Europe,America and south Asia,supplying obsolete and hard-to-find components to meet their specific needs.

With the principle of “Quality Parts,Customers Priority,Honest Operation,and Considerate Service”,our business mainly focus on the distribution of electronic components. Line cards we deal with include Microchip,ALPS,ROHM,Xilinx,Pulse,ON,Everlight and Freescale. Main products comprise IC,Modules,Potentiometer,IC Socket,Relay,Connector.Our parts cover such applications as commercial,industrial, and automotives areas.

We are looking forward to setting up business relationship with you and hope to provide you with the best service and solution. Let us make a better world for our industry!



## Contact us

Tel: +86-755-8981 8866 Fax: +86-755-8427 6832

Email & Skype: info@chipsmall.com Web: www.chipsmall.com

Address: A1208, Overseas Decoration Building, #122 Zhenhua RD., Futian, Shenzhen, China



# MAX17498B Evaluation Kit

## Evaluates: MAX17498B

### General Description

The MAX17498B evaluation kit (EV kit) is a fully assembled and tested circuit board that contains an isolated 7W flyback DC-DC converter. The circuit uses the MAX17498B current-mode, fixed-frequency flyback converter in a 16-pin TQFN package with an exposed pad. The EV kit demonstrates the IC's cycle-by-cycle current limit, soft-start, and UVLO features.

The EV kit circuit output is configured for an isolated +5V and provides up to 1.5A of current. Low cost and high efficiency up to 88% are achieved using a flyback DC-DC converter topology operating at a fixed 500kHz switching frequency. The surface-mount transformer provides up to +1500V galvanic isolation at the output.

The EV kit operates from a +18V to +36V power supply capable of providing up to 1A.

### Features

- ◆ +18V to +36V DC Voltage Input Range
- ◆ Isolated 5V, 1.5A Output
- ◆ Fixed 500kHz Switching Frequency
- ◆ 88% Efficiency
- ◆ Cycle-by-Cycle Current Limit
- ◆ High-Accuracy UVLO
- ◆ PGOOD Open-Drain Output
- ◆ Low-Cost Flyback Design
- ◆ Configurable for Primary-Side Regulation
- ◆ Proven PCB Layout
- ◆ Fully Assembled and Tested

[Ordering Information](#) appears at end of data sheet.

### Component List

DESIGNATION	QTY	DESCRIPTION
C1	1	47 $\mu$ F $\pm$ 20%, 63V electrolytic capacitor (8mm x 10.2mm) Panasonic EEE-FK1J470P
C2, C4	2	4.7 $\mu$ F $\pm$ 10%, 50V X7R ceramic capacitors (1210) Murata GRM32ER71H475KA88L
C3	1	33nF $\pm$ 10%, 50V X7R ceramic capacitor (0805) Murata GRM219R71H333K
C5	1	0.22 $\mu$ F $\pm$ 10%, 50V X7R ceramic capacitor (0603) Murata GCM188R71H224KA64D
C6	1	2.2 $\mu$ F $\pm$ 10%, 16V X7R ceramic capacitor (0805) Murata GRM21BR71C225KA12L
C7	1	47pF $\pm$ 5%, 50V C0G ceramic capacitor (0603) Murata GRM1885C1H470J
C8, C18	0	Not installed, capacitors (0603) C8 is short (PC trace) and C18 is open
C9	1	68nF $\pm$ 10%, 16V X7R ceramic capacitor (0603) Murata GRM188R71C683K

DESIGNATION	QTY	DESCRIPTION
C10	1	100pF $\pm$ 5%, 50V C0G ceramic capacitor (0603) Murata GRM1885C1H101JA01D
C11	1	2.2 $\mu$ F $\pm$ 10%, 10V X7R ceramic capacitor (0805) Murata GRM21BR71A225KA01L
C12, C13, C14	3	22 $\mu$ F $\pm$ 10%, 16V X7R ceramic capacitors (1210) TDK C3225X7R1C226K
C15	1	4.7nF $\pm$ 10%, 50V X7R ceramic capacitor (0603) Murata GRM188R71H472KA01D
C16	1	33pF $\pm$ 5%, 50V X7R ceramic capacitor (0603) Murata GRM1885C1H330JA01D
C17	0	Not installed, capacitor (0805)
D1	1	150V, 1A rectifier (SMA) Diodes Inc. ES1C-13-F
D2	1	40V, 300mA rectifier (SOD123) Diodes Inc. SD103AW-13-F
D3	1	50V, 5A rectifier (SMC) Diodes Inc. B550C-13-F
D4	0	Not installed, diode (SOT323)



# MAX17498B Evaluation Kit

## Evaluates: MAX17498B

### Component List (continued)

DESIGNATION	QTY	DESCRIPTION
R1	1	7.5k $\Omega$ $\pm$ 1%, 1/2W resistor (1206) Stackpole Electronics RNCP1206FTD7K50
R3	1	348k $\Omega$ $\pm$ 1% resistor (0603)
R4	1	20k $\Omega$ $\pm$ 1% resistor (0603)
R5, R9, R19	3	10k $\Omega$ $\pm$ 1% resistors (0603)
R6	1	86.6k $\Omega$ $\pm$ 1% resistor (0603)
R7	1	0 $\Omega$ $\pm$ 5% resistor (0603)
R8, R10, R14, R16, R17, R21, R22	0	Not installed, resistors (0603)
R11, R18	2	15k $\Omega$ $\pm$ 1% resistors (0603)
R12	1	10k $\Omega$ $\pm$ 5% resistor (0603)
R13	1	511 $\Omega$ $\pm$ 1% resistor (0603)

DESIGNATION	QTY	DESCRIPTION
R15	1	1k $\Omega$ $\pm$ 1% resistor (0603)
R20	1	30.1k $\Omega$ $\pm$ 1% resistor (0603)
T1	1	30W transformer (1:2:4) Coilcraft MA5237-AL
U1	1	Offline 500kHz peak current-mode controller (16 TQFN-EP*) Maxim MAX17498BATE+
U2	1	Phototransistor/optocoupler (6 Dip Gull Wing) Avago 4N35-300E
U3	1	1.24V shunt regulator (3 SOT23) Diodes Inc. TLV431BFTA
—	1	PCB: MAX17498B EVALUATION KIT

\*EP = Exposed pad.

### Component Suppliers

SUPPLIER	PHONE	WEBSITE
Coilcraft, Inc.	847-639-6400	www.coilcraft.com
Diodes Incorporated	805-446-4800	www.diodes.com
Murata Electronics North America, Inc.	770-436-1300	www.murata-northamerica.com
Panasonic Corp.	800-344-2112	www.panasonic.com
TDK Corp	847-803-6100	www.component.tdk.com

**Note:** Indicate that you are using the MAX17498B when contacting these component suppliers.

### Quick Start

#### Required Equipment

- MAX17498B EV kit
- +18V to +36V power supply capable of providing up to 1A
- Two voltmeters
- Electronic load capable of sinking 1.5A

#### Procedure

The EV kit is fully assembled and tested. Follow the steps below to verify board operation. **Caution: Do not turn on the power supply until all connections are completed.**

- 1) Connect the first voltmeter to the VIN and PGND PCB pads.
- 2) Connect the second voltmeter to the VOUT and GND PCB pads.
- 3) Connect the positive and negative terminals of the electronic load to the VOUT and PGND banana jacks, respectively.

- 4) Connect the power supply's positive terminal to the VIN PCB pad. Connect the power supply's ground to the PGND PCB pad.
- 5) Turn on the power supply above +18V.
- 6) Enable the electronic load and set it to 1.5A.
- 7) Verify that the voltmeter at VOUT reads approximately +5V.

### Detailed Description of Hardware

The MAX17498B EV kit is a fully assembled and tested circuit board that contains the MAX17498B isolated 7W flyback DC-DC converter. The EV kit circuit output provides +5V and can supply up to 1.5A. The circuit can be powered from a +18V to +36V DC source.

The flyback DC-DC converter operates at a fixed 500kHz operating frequency and achieves up to 88% efficiency. The EV kit provides cycle-by-cycle, primary-side current-limit protection using the IC's internal MOSFET switch, which is connected at the LX input. Resistor R6 sets

# MAX17498B Evaluation Kit

## Evaluates: MAX17498B

the circuit peak current limit to 1.7A using transformer T1's primary winding and the IC internal switch. The EV kit features an RCD snubber network (R1, C3, and D1) to minimize leakage energy ringing and to clamp the voltage at the LX input. The surface-mount transformer provides galvanic isolation up to +1500V for the output.

The isolated +5V output is set using the transformer secondary-side, opto-coupler (U2), shunt regulator (U3), resistors (R9, R19, R20), and various other components. The EV kit circuit startup process begins when the voltage at IN is greater than the circuit's +15.6V undervoltage threshold and a current-limit fault is not present. Resistors R3, R4, and R5 set the undervoltage- and overvoltage-threshold voltages to +15.6V and +46V, respectively. Soft-start capacitor C9 programs the circuit soft-start period to 8ms. Upon the circuit rising above its undervoltage lockout (UVLO), the LX node begins switching and energy is transferred from the transformer primary side to the secondary side for the regulated +5V output.

UVLO provides controlled turn-on and shutdown during brownouts, power-up, or power-down. The EV kit circuit UVLO is set to +15.6V. The circuit overvoltage threshold (OVI) is set to +46V. EN/UVLO and OVI PCB pads are available for monitoring the voltages at the IC's EN/UVLO and OVI inputs, respectively.

The EV kit circuit can also be reconfigured for primary-side regulation using the transformer bias winding and feedback resistors R8 and R10. See the *Reconfiguring the EV Kit for Primary-Side Regulation* section for additional information. Also refer to the MAX17498A/MAX17498B/MAX17498C IC data sheet for additional information.

### Current Limiting

The IC features current limiting for the transformer's primary side by monitoring the peak current entering the IC's LX input. Resistor R6 sets the EV kit circuit current limit to 1.7A. The IC turns off its internal switch when the peak current reaches the current limit. To reconfigure the peak current limit to a different value, use the following equation to choose a new R6 resistor:

$$R6 = 50 \times I_{PEAK}$$

where  $I_{PEAK}$  is in amps and R6 is in k $\Omega$ .

### Undervoltage Lockout and Overvoltage Protection

The EV kit features UVLO and OVI circuits that prevent operation below the programmed input supply startup voltage and above the overvoltage threshold. Resistors R3, R4, and R5 set the undervoltage and overvoltage thresholds. The circuit's undervoltage and overvoltage thresholds are set at +15.6V and +46V, respectively. To reconfigure the UVLO and OVI voltages, refer to the *Startup Voltage and Input Overvoltage-Protection Setting (EN/UVLO, OVI)* section in the MAX17498A/MAX17498B/MAX17498C IC data sheet

EN/UVLO and OVI PCB pads are available for monitoring the voltages present at the respective inputs.

### Power-Good Output (PGOOD)

The EV kit provides a PCB pad to monitor the status of the power-good output. PGOOD is high when VOUT is within 5% of its regulated voltage. When VOUT falls below 92% (typ) of its regulated voltage, PGOOD is pulled low. PGOOD is pulled up to VCC through resistor R12.

### Reconfiguring the EV Kit for Primary-Side Regulation

The EV kit also supports an isolated DC-DC converter design using primary-side regulation. The transformer's bias winding and resistor PCB pads R8 and R10 are used to set the EV kit circuit output voltage. When reconfiguring the EV kit for primary-side regulation, the following modifications must be made:

- Remove resistors R13, R15, and R20
- Replace resistor R9 with a 0 $\Omega$  0603 footprint
- Install required 0603 resistors R8 and R10 for feedback regulation
- Install required 0603 capacitors C7 and C8 for loop compensation

Refer to the MAX17498A/MAX17498B/MAX17498C IC data sheet for selecting R8, R10, C7, and C8.

# MAX17498B Evaluation Kit

## Evaluates: MAX17498B

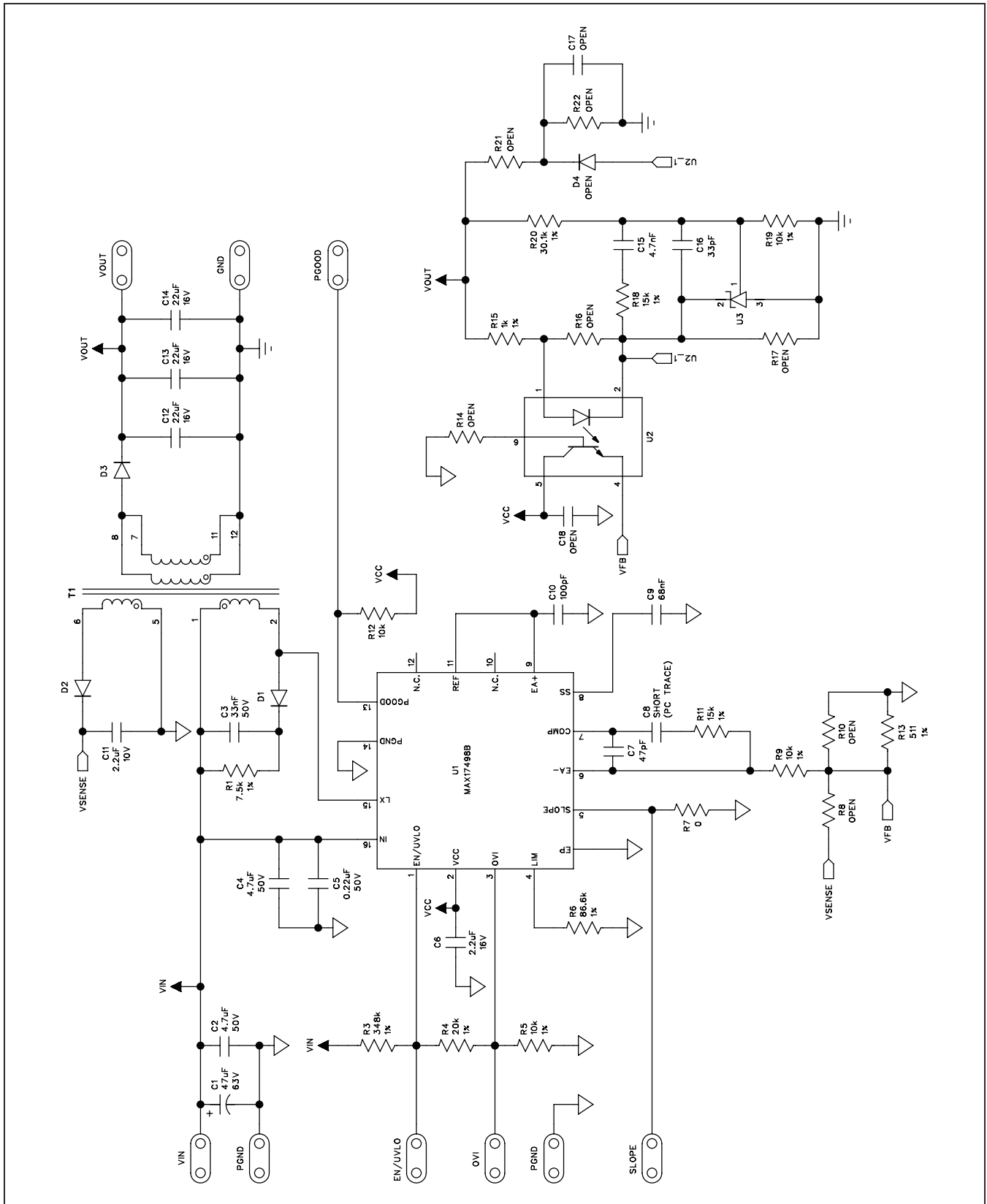

Figure1. MAX17498B EV Kit Schematic

# MAX17498B Evaluation Kit

## Evaluates: MAX17498B

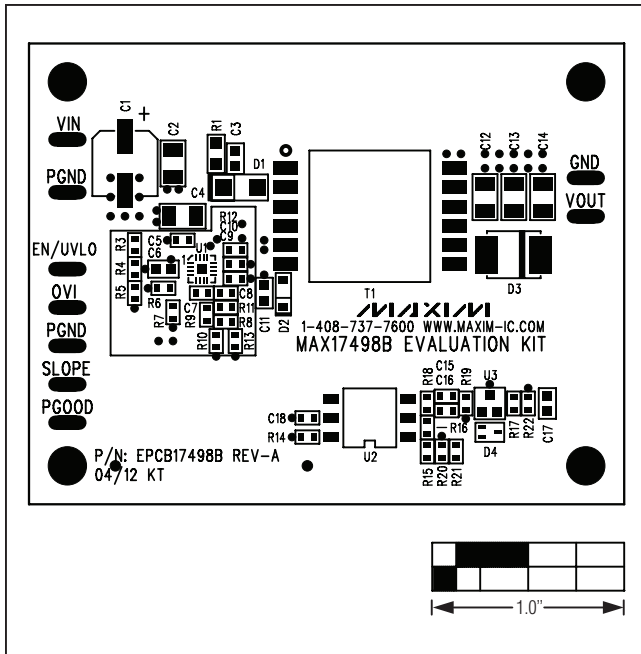

Figure 2. MAX17498B EV Kit Component Placement Guide—Component Side

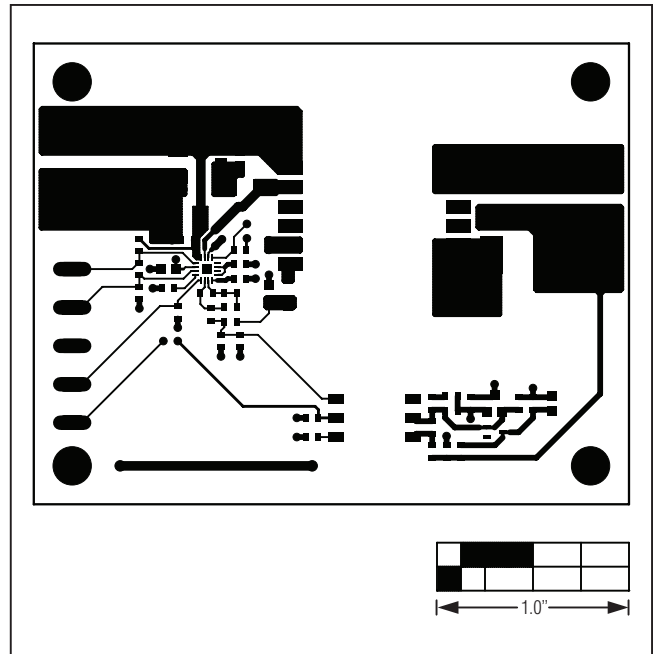

Figure 3. MAX17498B EV Kit PCB Layout—Component Side

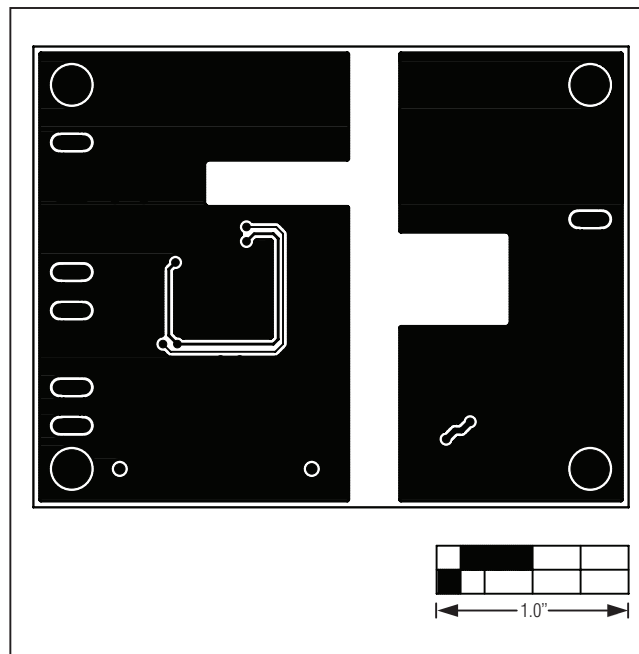

Figure 4. MAX17498B EV Kit PCB Layout—Solder Side

# MAX17498B Evaluation Kit

## Evaluates: MAX17498B

### ***Ordering Information***

---

<b>PART</b>	<b>TYPE</b>
MAX17498BEVKIT#	EV Kit

#Denotes RoHS compliant.

# MAX17498B Evaluation Kit

## Evaluates: MAX17498B

### *Revision History*

REVISION NUMBER	REVISION DATE	DESCRIPTION	PAGES CHANGED
0	4/12	Initial release	—

*Maxim cannot assume responsibility for use of any circuitry other than circuitry entirely embodied in a Maxim product. No circuit patent licenses are implied. Maxim reserves the right to change the circuitry and specifications without notice at any time.*

**Maxim Integrated Products, 120 San Gabriel Drive, Sunnyvale, CA 94086 408-737-7600 \_\_\_\_\_ 7**