



Chipsmall Limited consists of a professional team with an average of over 10 year of expertise in the distribution of electronic components. Based in Hongkong, we have already established firm and mutual-benefit business relationships with customers from,Europe,America and south Asia,supplying obsolete and hard-to-find components to meet their specific needs.

With the principle of “Quality Parts,Customers Priority,Honest Operation,and Considerate Service”,our business mainly focus on the distribution of electronic components. Line cards we deal with include Microchip,ALPS,ROHM,Xilinx,Pulse,ON,Everlight and Freescale. Main products comprise IC,Modules,Potentiometer,IC Socket,Relay,Connector.Our parts cover such applications as commercial,industrial, and automotives areas.

We are looking forward to setting up business relationship with you and hope to provide you with the best service and solution. Let us make a better world for our industry!



## Contact us

Tel: +86-755-8981 8866 Fax: +86-755-8427 6832

Email & Skype: info@chipsmall.com Web: www.chipsmall.com

Address: A1208, Overseas Decoration Building, #122 Zhenhua RD., Futian, Shenzhen, China





# EE-SIM Design and Simulation Environment User Guide

*UG5861; Rev 0; 6/16*

## Abstract

This User Guide contains detailed instructions for using the EE-Sim Design and Simulation Environment. This free online tool suite enables design, simulation, analysis, and purchasing ability for a variety of analog and power solutions. The EE-Sim System Power tool provides customized DC-DC and sequencer recommendations for multi-rail or multi-load systems including processor, SoC,  $\mu$ C, and FPGA designs. EE-Sim tools automatically create a circuit schematic based on your requirements, saving precious design time and resources. Set up and complete simulations in just minutes. Take advantage of additional features such as sharing designs with colleagues, ordering BOMs from distributors, printing complete reports, and downloading a free version of EE-Sim SE, which includes node-locked versions of the Simplis and SIMetrix simulation engines.

# CONTENTS

<b>1</b>	<b>Getting Started</b>	<b>4</b>
1.1	Introduction	4
1.2	Basic User Prerequisites	4
1.3	Conventions Used in This Manual	4
1.4	Register as a New User	5
1.5	Open the EE-Sim Tool Suite	5
1.5.1	Start a New EE-Sim Design	5
1.5.2	Start EE-Sim as the Recipient of a Shared Design	6
1.5.3	Open an Existing Design	6
1.5.4	Save Changes to Your Own Design	7
1.5.5	Save Changes to a Shared Design	7
1.5.6	Close the EE-Sim Tools	8
1.6	Web Browsers Support Easy Automatic Logins	8
<b>2</b>	<b>Designs, Contacts, and Sharing</b>	<b>9</b>
2.1	My Designs	9
2.1.1	Create a New Contact	10
2.1.2	Manage Your Contacts	10
2.1.3	Share a Single Design	11
2.1.4	Share Multiple Designs	11
2.2	Use Reference Designs from Maxim	12
<b>3</b>	<b>DC-DC Converter Designs V2 (Beta)</b>	<b>13</b>
3.1	Open an Existing Design	13
3.2	Create a New Design	14
3.3	Specify Input, Output, and Other Design Requirements	14
3.4	Create a Schematic and Save Your Design	15
3.5	Next Steps	15
3.6	Edit a Schematic	16
3.6.1	Edit Component Properties	16
3.6.2	Select a New Vendor Part	17
3.6.3	Annotate a Schematic Using the Toolbar	19
3.6.4	Schematic Toolbar Reference Chart	21
3.6.5	Version History	25
3.7	Simulation and Analysis	26
3.7.1	Run a Simulation and Generate Waveforms	26
3.7.2	View Simulation Waveforms	28
3.7.3	Customize the Waveform Viewer Output	28
3.8	Compare Design Iterations	34
3.9	Generate a Design Report and BOM (DC-DC)	36
3.9.1	Publish a Design Report and BOM	36
3.9.2	Download the BOM, Report, and Schematic	37
<b>4</b>	<b>DC-DC Converter Designs V1</b>	<b>38</b>
4.1	Creating a New Design	38

4.2	Specifying Input, Output, and Other Design Requirements .....	38
4.3	Generating a Schematic and Saving Your Design .....	39
4.4	Next Steps .....	39
4.5	Modifying Schematics.....	40
4.5.1	Modifying Product Components .....	40
4.6	Simulation and Analysis.....	41
4.6.1	Running a Simulation and Generating Waveforms.....	41
4.7	Generating Summary Page and BOM .....	43
4.7.1	Generating and Printing a Summary Page.....	43
4.7.2	Generating and Saving a BOM .....	43
<b>5</b>	<b>System Power Designs .....</b>	<b>45</b>
5.1	Create a New System Power Processor Design .....	45
5.1.1	Create a New FPGA Processor Design and Schematic .....	45
5.1.2	Create a New Processor/SoC/Custom Load Design and Schematic.....	46
5.2	Next Steps .....	46
5.3	Modifying System Power Schematics.....	47
5.3.1	Add and Connect Product Components.....	47
5.3.2	Select a Component.....	48
5.4	Sequencing.....	49
5.4.1	Add a Sequencer.....	49
5.4.2	Edit the Group/Rail Assignments and View the Timing Diagrams.....	50
5.5	Generate a Summary Page and BOM (System Power) .....	50
5.5.1	Explore the System Power Tool Summary Page .....	50
5.5.2	Generate and Print a Summary Page.....	51
5.5.3	Generate and Save a BOM .....	52
<b>6</b>	<b>Filter Designs .....</b>	<b>53</b>
<b>7</b>	<b>PLL/VCO Designs.....</b>	<b>54</b>
<b>8</b>	<b>EE-Sim SE (Offline Edition for Windows).....</b>	<b>55</b>
8.1	Download EE-Sim SE .....	55
8.2	Install EE-Sim SE .....	55
8.3	Start Using the EE-Sim SE Application for Windows.....	58
8.4	Download a Schematic .....	60
<b>9</b>	<b>Trademarks.....</b>	<b>62</b>

---

# 1 Getting Started

---

## 1.1 Introduction

The Maxim EE-Sim® tool suite enables registered members of the Maxim Integrated online community to design, simulate, analyze, and purchase a variety of analog and power solutions.

Automatically create a circuit schematic based on your requirements in the EE-Sim environment, saving precious design time and resources. Set up and complete simulations in just minutes, and take advantage of the following additional EE-Sim tool features:

- Share designs with colleagues.
- Order a bill of materials (BOM) from your preferred distributor.
- Electronically download, send, or print a complete design report with customized schematics and simulation graphs.
- Download a free version of the EE-Sim Simulation Engines (EE-Sim SE) for more detailed and flexible simulation capabilities.

While using EE-Sim tools, don't forget to explore the other features and benefits of online membership with Maxim Integrated.

## 1.2 Basic User Prerequisites

This manual assumes you are familiar with basic use of the Windows® or Mac OS®X operating systems, user interfaces, and supported web browsers. For example, click, double-click, hold your mouse down, drag, release a mouse, and identify different mouse pointers or cursor icons and know what they mean. For example, wait for a spinning pointer or click a hyperlink with the familiar first finger of the Link Select mouse pointer. While no claim of ADA or Section 508 compliance is made, because this tool runs in a web browser, additional screen readers and input devices are considered compatible.

## 1.3 Conventions Used in This Manual

- Items in a list where one or more choices or lists of substeps that can be perform in *any order* appear with bullets. For example:
  - Option 1
  - Option 2
  - Option 3
- Items in a procedure where each step should be performed in a recommended and often required sequence appear in numbered and lettered lists. Verify that you complete a step before attempting the next step. For example:
  1. Step 1
  2. Step 2
    - a. Substep 2a
    - b. Substep 2b
  3. Step 3
- Key areas of screen images appear with callout numbers in circles and are explained in greater detail with matching numbers in a table below the infographic. These infographics often imply a recommended sequence, but they do not represent a series of required steps in a procedure. The screenshots are sometimes modified to demonstrate how the software behaves.

- Items in *italics* represent an emphasis in tone, a special term, or a specific field value to read on screen, select, or enter.
- Items in **bold** represent user interface labels for buttons, fields, messages, tabs, and other items that can be clicked with a mouse or tapped with a supported touchscreen device.
- Items that appear underlined in a **monospace font** represent data values that must be entered exactly as they appear. For example, maximintegrated.com or 7.25.
- This manual uses *click* as a standard term. If using a touchscreen device you can *tap* links and buttons instead of clicking on them. This manual uses *press* (i.e., press the **Enter key**) as a standard term. Where supported, *enter* values using your choice of input device.
- This manual uses *select* (i.e., select a design to open) as a standard term. Where supported, click, tap, or use a keyboard to select an item.
- This manual uses *choose* (i.e., choose a color) as a standard term. Where supported, click, tap, or use a keyboard to choose an item.

## 1.4 Register as a New User

As a new user, start here to register and create a MyMaxim account profile and password.

1. Open your web browser and navigate to [www.maximintegrated.com](http://www.maximintegrated.com).
2. At the top of the page, click **Register**. If your user name appears at the top of the page and you do not see a **Register** button, you are already registered and logged in. Skip the remaining steps in this procedure.
3. If you arrived at the EE-Sim gateway page ([www.maximintegrated.com/ee-sim](http://www.maximintegrated.com/ee-sim)) through a shared design or another web link, and you are a new user, click **Register if you are a new user**.
4. Enter your contact information, e-mail address, and specify a secure password. You must enter a valid e-mail address. Your e-mail address is your user ID.
5. Click **Submit**.
6. Open the desktop application, website, or mobile device you use to access e-mail for the account you used to register.
7. Look for a new e-mail message in your inbox with the subject line **Maxim Member Center Notifier** from the *Maxim Member System*. Open the message and click the activation link.
8. Welcome! You are now a new member of the Maxim Integrated online community.

**NOTE:** By registering for a web account, you agree to the terms outlined in our Privacy Policy.

## 1.5 Open the EE-Sim Tool Suite

As a registered user, you can now start using the EE-Sim tools.

### 1.5.1 Start a New EE-Sim Design

Use this procedure if you are new to Maxim Integrated and using the EE-Sim tools for the first time.

1. In a supported web browser, navigate to [www.maximintegrated.com](http://www.maximintegrated.com).
2. Start the EE-Sim tool suite using any one of the following options:
  - Click the **Design** menu, click **Design Tools**, then under **EE-Sim** click **Design and Simulation Tools (Online)**.
  - Search for a part and click its Design Resources tab. For parts that have an EE-Sim model available, click the **Design and Simulate** link under **Tools & Models**.

- Create a bookmark or favorites link to [www.maximintegrated.com/ee\\_sim](http://www.maximintegrated.com/ee_sim).
3. If you did not already register, complete the steps in 1.4 [Register as a New User](#). Return to Step 2 if necessary.
  4. As a registered user with Maxim Integrated, click **Login if you are a returning user** and begin using the tools.

NOTE: If your user name appears at the top of the page and you do not see a **Login** option, you are already logged in and can skip the next step.

5. On the **Member Log In** page:
  - a. In the **User Name** field, enter your e-mail address.
  - b. In the **Password** field, enter your password for your Maxim account.
  - c. Click the **Log In** button.
6. On the EE-Sim main page:
  - a. Click the **My Designs** tab to view saved designs and any designs shared with you.
  - b. Click the **New** tab to create a new design.

## 1.5.2 Start EE-Sim as the Recipient of a Shared Design

Use the steps below if you receive an invitation by e-mail to open a shared design.

NOTE: If this is the first time you are visiting the Maxim Integrated online member community, navigate to <https://memcenter.maximintegrated.com> and click **Register for Membership**. To register, complete the steps in 1.4 Register as a New User.

1. Open your e-mail application, website, or mobile device app that you use to access e-mail (for example, Microsoft Outlook or Gmail®).
2. Open the e-mail message about the shared design you have been invited to view:
  - a. Examine the subject line and notes at the bottom of the invitation. The owner of the design may have included special instructions for you.
  - b. The name of the design and your permissions appear. For example, you can have *Read/Write* permissions for one design and *Read Only* permissions for another design.
  - c. Click the **Accept this Invitation** link. If you already registered, click the link to the shared design in the sender's e-mail invitation. If not registered, see the note above.
3. If you are logged in, skip ahead to the next step. If you are not logged in automatically, complete the **Member Login** page:
  - a. In the **E-mail Address** field, enter the e-mail address that you used to register with Maxim.
  - b. In the **Password** field, enter your password for your Maxim account.
  - c. Click the **Log In** button.
4. On the EE-Sim gateway page ([www.maximintegrated.com/ee-sim](http://www.maximintegrated.com/ee-sim)):
  - a. Click the **My Designs** tab to view the shared design and any additional designs that you save or receive through sharing.
  - b. Click a design to open it.

## 1.5.3 Open an Existing Design

Use this procedure to open and resume work on a saved design, or open a shared design.

1. Open a web browser and navigate to [www.maximintegrated.com/ee\\_sim/](http://www.maximintegrated.com/ee_sim/).
2. If you are logged in, click **Start the EE-Sim tool** and skip the next step.
3. If you are not logged in automatically, click **Login if you are a returning user** and complete the **Member Login** page:
  - a. In the **E-mail Address** field, enter the e-mail address used during registration.
  - b. In the **Password** field, enter the password for your Maxim account.
  - c. Click the **Log Me In** button.
  - d. On the **Login Successful** page, click **Start the EE-Sim tool**.

4. Click the **My Designs** tab.
5. On the **My Designs** page, click the **Name** link or position your mouse over a design and click the **Open** button.
6. If the message, "**Starting a new design overwrites any changes in your current design**" appears, click **Start New Design**.
7. Your design opens at the last saved page in the design process.

## 1.5.4 Save Changes to Your Own Design

1. Save a design you created using its existing name, or save it as a new design with a new name: Click the **My Designs** tab.
2. On the **My Designs** page, click the **Name** link or position your mouse over a design and click the **Open** button to open the design.
3. If another design is already open, the following message appears:  
**Starting a new design overwrites any changes in your current design.**
4. Click **Start New Design** to open the design.
5. Make any changes to the design.
6. Click the **Save** button to save your design. To save changes keeping the same design name, click **Save** again in the **Save Your Design** window.
7. To save your design changes as a new design, continue with the remaining sub-steps:
  - a. In the **Design Name** field, enter a unique new name to differentiate this design from your other designs as well as the shared designs of other users. For example, save the *MAXIM 17598 MyDesign1* design as *MAXIM 17598 MyDesign2*.
  - b. In the **Design Description** field, enter a short description of the modified design for you and any recipients if you later decide to share the design.
  - c. Click **Save**.

## 1.5.5 Save Changes to a Shared Design

A shared design can always be saved as a new design by saving it using a new name. Someone with Read/Write access can also save a shared design using its original name, overwriting the original design.

1. Click the **My Designs** tab.
2. On the **My Designs** page, click the **Name** link or position your mouse over a design and click the **Open** button to open the design.
3. If another design is already open, the following message appears:  
**Starting a new design overwrites any changes in your current design.**
4. Click **Start New Design** to open the design.
5. Make any changes to the design.
6. Click the **Save** button to save your design.
  - a. If you have Read-Only access to the shared design or simply want to save your shared design changes as a new personal design that is not shared, continue with the remaining sub-steps:
    - i. In the **Design Name** field, enter a unique new name to differentiate this design from your other designs as well as the shared designs of other users. For example, save the *MAXIM 17598 MyDesign-001* design as *MAXIM 17598 MyDesign-002*.
    - ii. In the **Design Description** field, enter a short description of the modified design for you and any recipients if you decide to share the design.
    - iii. Click **Save**.
  - b. If you have Read/Write permission, you can overwrite the original design. Updates are applied to the design and it maintains the same name. The person who shared this design can also view these changes.
    - i. In the **Save Your Design** window, do not change the design name.
    - ii. Click **Save**.



## 1.5.6 Close the EE-Sim Tools

The EE-Sim tool suite is designed for ease-of-use. After logging in, you can end your session at any time and resume work again without being forced to logout or log back in again.

Follow these steps to end the session.

1. Click the **Save** button to save any changes made to your design.
2. Close your browser.

**NOTE:** The next time you start the EE-Sim tools, you are logged in automatically unless you manually or automatically clear cookies from your browser, or log out of the Maxim website. If you delete your cookies or logout of the Maxim website, login to the Maxim website again to confirm your identify before using the EE-Sim tools.

## 1.6 Web Browsers Support Easy Automatic Logins

When you log in to the Maxim Integrated website, you can rely on standard security protocols to keep you logged in as a convenience. If you return to the site and are not automatically logged back in, you have to manually enter your login credentials again. You may encounter this behavior for any of the following reasons, all involving options available to you through your choice of supported web browser (Microsoft Internet Explorer® 9 or higher, Google Chrome®, or Mozilla Firefox):

- You cleared browser cookies after the last successful login. Cookie settings might be cleared on a shared workstation by a network security policy, or cleared from your own PC as a personal preference, or by an anti-virus program.
- You are browsing in the web browser's private or incognito mode.
- You are using a different browser, computer, or device from the one used to login last time.

# 2 Designs, Contacts, and Sharing

## 2.1 My Designs

There is no particular procedure to follow when it comes to managing designs. As you create and share them, your design list grows. Refer to the following image to get started.

The screenshot shows the 'My Designs' page in the EE-Sim application. At the top left is the Maxim Integrated logo. The page has tabs for 'New', 'My Designs', 'Maxim Designs', and 'Download'. A 'Return to Current Design' button is highlighted with a circled '1'. Below the tabs, a message says 'These are your saved designs. Hover to see info.' A table of designs is shown with columns for Name, Date, Status, and Type. The table is sorted by Date in descending order, indicated by a downward arrow in the Date header (circled '2'). The third row is selected, and a detailed view is shown on the right (circled '4'). This view includes the design name, description, date, status, and type. It also shows sharing options: 'Open', 'Share', and 'Delete'. A 'Shared:' section shows a contact 'my.contact@who.net' with 'Read Only' permission. At the bottom of the table, navigation links 'First', 'Previous', '1', '2', '3', 'Next', and 'Last' are visible, with '1' highlighted (circled '5').

Name	Date	Status	Type
<a href="#">George N. Jinere</a> Great new design for customers in new s...	10/25/2013 4:48 PM	Owner	DC-DC
<a href="#">ED-MAX-16907/09 DRAFT-001</a> DC-DC design description.	10/25/2013 4:45 PM	Owner	DC-DC
<a href="#">20131025-MAX-17597-DESIGN-1</a> Government customer interested in our p...	10/25/2013 4:43 PM	Owner	DC-DC
<a href="#">MAXIM 17598 20131019-002</a> Version 2: A new approved design with a...	10/25/2013 4:26 PM	Owner	DC-DC
<a href="#">MAXIM 17598 20131019-001</a> A new approved design with approved pa...	10/25/2013 4:25 PM	Owner	DC-DC
<a href="#">Design 20131024-001</a> Description.	10/24/2013 4:01 PM	Owner	DC-DC
<a href="#">System Power Design 004</a> System Power design for 12-rail process...	10/19/2013 9:24 AM	Owner	System-Power
<a href="#">New Design 03</a> A new design for project P2 for 2015 Q1.	10/19/2013 9:15 AM	Read Only	DC-DC
<a href="#">My Original Design 001</a> Original shared design from my colleague.	10/19/2013 6:10 AM	Owner	DC-DC
<a href="#">2014 MyDesign 002</a> A second design based on the MAX 175...	10/19/2013 6:09 AM	Owner	DC-DC

- 1 My Designs:** Click the **My Designs** tab to view, manage, sort, open, share, and delete designs. If you navigate to the **My Designs** page from an open design, a **Return to Current Design** button appears to take you back to the last page you were viewing to continue working on the open design. A button can also appear for the last EE-Sim design tool open. Possible button names include **Return to DC-DC Tool**, **Return to System Power Tool**, **Return to PLL Tool**, or **Return to Filter Tool**.
- 2 Header Labels Show the Sort Order:** Click a column header to toggle the ascending or descending sort order for each column. In this example, the entire table of designs is sorted by date in descending order and is indicated by the arrow pointing down in the **Date** column header.
- 3 Open a Design:** Click the design name hyperlink to open a design. The value in the **Status** field indicates your permission level for that design including *Read Only*, *Read/Write*, or *Owner*.
- 4 Sharing:** Position your mouse over a row in the designs table to view its full description, shared contacts, and permissions. Available buttons include **Open**, **Share**, and **Delete**. In the top example, the owner of a DC-DC design has not shared it with anyone. In the bottom example, a contact person has been granted Read-Only permission to a System-Power design.
- 5 Navigation:** Use the convenient links at the bottom of the list to navigate through multiple pages with up to ten designs appearing on each page.

## 2.1.1 Create a New Contact

Before sharing a design with a colleague, you must add them as a new contact.

1. Click the **My Designs** tab.
2. Click the **Go to My Contacts** button.
3. In the **Add New Contact** field:
  - a. Enter the e-mail address for your new contact.
  - b. Click **Add Contact**.
4. In the **Invite Preview** section:
  - a. In the **Subject** field, enter a subject line for the e-mail message to your new contact.
  - b. In the **Message** section, enter a custom greeting to follow the **Hello** line and your name as the person sending the invitation. Add custom notes at the bottom of the invitation if desired.
5. Click **Add Designs to Share** to assign permissions to one or more of your designs for your new contact to view or edit them. In the **Share multiple designs with** window:
  - a. Select the **Read/Write** option to enable the new contact to edit the shared design.
  - b. Select the **Read Only** option to enable the new contact to view the design. Your original design is preserved. The recipient can save their own copy of the design.
  - c. Select the **No Access** option to restrict permissions. Designs with this option are not shared.
  - d. Click **Apply**.
6. Review the invitation and click **Send Invite**.

**NOTE:** New contacts can appear in the **Pending Contacts** section until they accept your invitation.

7. (Optional) To revise the invitation, click **Resend Invite**.
8. To return to your designs, click the **Go to My Designs** button.

## 2.1.2 Manage Your Contacts

Use the My Contacts page to help you organize your contacts, send e-mail invitations, and set sharing permissions for collaboration in viewing, approving, or developing new designs.

1. Click the **My Designs** tab.
2. Click the **Go to My Contacts** button.
3. In the **My Contacts** section:
  - a. Click a column header to sort contacts by their e-mail account or by the number of designs shared with *Read/Write* or *Read Only* permissions.
  - b. Position your mouse over a contact to view the names of any shared designs.
  - c. Click **First** or **Last** to jump to the first or last page in the list.
  - d. Click **Previous** or **Next** to go back or advance one page at a time.
  - e. Click a page number to view that page of ten contacts. The current page is shown with a border around its number.
4. Click **Manage** to set the design sharing permissions that you want to grant to this contact, if any. In the resulting **Share multiple designs...** window:
  - a. Click a column header to sort the list by design name or permitted level of access.
  - b. Click **Apply** to save any new permissions.
  - c. Click **Preview and Send Invitation** to notify your contact with a personalized message about the design sharing changes you just made.
  - d. (Optional) Click **Share with a new contact** to exit this window and share designs with a new contact. To learn more, see *2.1.1 Create a New Contact*.
5. New contacts are added to the **Pending Contacts** section when their e-mail address is not recognized as an existing EE-Sim user. In the **Pending Contacts** section, perform any of the following actions:

- a. Click a column header to sort contacts by their e-mail account, invitation date, shared designs, or sharing action.
- b. Click **First** or **Last** to jump to the first or last page in the list.
- c. Click **Previous** or **Next** to go back or advance one page at a time.
- d. Click a page number to view that page of ten contacts. The current page is shown with a border around its number.
- e. Click **Resend Invite** to adjust any design sharing permissions, edit your personalized invitation, and e-mail it to the pending contact again.
6. In the **Add New Contact** section, enter an email address and click **Add Contact** to begin the sharing process or just notify another contact.
7. Click **Go to My Designs** when finished to return to your list of designs.

### 2.1.3 Share a Single Design

Use this procedure to share a specific design with a contact. Select the design to be shared.

1. Option 1. On the **My Designs** page, position your mouse over the design you want to share. In the dynamic status area that appears on the right side, click **Share**.
  - a. In the **Manage Permissions** window for the selected design, select *Read/Write*, *Read Only*, or *No Access* for each contact in the list. (This option enables you to share the design with multiple contacts.)
  - b. (Optional) Click **Apply** to save your settings.
  - c. Click **Preview and Send Invitation**.
2. Option 2. Open a design and click the **Share** button in the upper right corner of the Schematic page.
  - a. In the **Share Your Design** window, in the **Share With** field, select a contact or click **Add Contact** to enter a new contact.
  - b. In the **Set Permissions Level** field, choose *Read Only* or *Read/Write*.

**NOTE:** For both options, continue with the following common steps.

3. In the **Subject** field, enter a short title for the e-mail message to the new or existing contact.
4. In the **Message** section, ensure your name is shown as the person sharing a design. Add notes in the **Additional comments** field at the bottom of the invitation.
5. Review the invitation and click **Send Invite**.

### 2.1.4 Share Multiple Designs

Use this procedure to share multiple designs at the same time with a single contact.

1. On the **My Designs** page, click **Go to My Contacts**.
2. On the **My Contacts** page, locate a specific contact in the list and click the **Manage** button.
3. In the **Share Multiple Designs** window:
  - a. Select *Read/Write* or *Read Only* for each design in the list. Select *No Access* to disable sharing of that design.
  - b. (Optional) Click **Apply** to save your settings.
  - c. Click **Preview and Send Invitation**.
4. In the **Subject** field, enter a short title for the e-mail message to your contact.
5. In the **Message** section, ensure your name is shown as the person sharing a design. Add notes in the **Additional comments** field at the bottom of the invitation.
6. Review the invitation and click **Send Invite**.

## 2.2 Use Reference Designs from Maxim

The **Maxim Designs** tab includes a set of reference circuit designs built and tested by the experts at Maxim Integrated. Use a reference design to accelerate your productivity. Save time by basing your new schematic on a proven existing design. Many of these designs are also available for purchase as evaluation boards. Reference designs identified as MAXREFDES are available for immediate purchase.

Follow these steps to create a new design based on an existing reference design:

1. Open your web browser and navigate to [www.maximintegrated.com/ee\\_sim/](http://www.maximintegrated.com/ee_sim/).
2. Click **Start the EE-Sim tool**. If you were not automatically logged in, click **Login if you are a returning user**.
3. Click the **Maxim Designs** tab. The **DC-DC Converters** section expands.

**NOTE:** This release provides Reference Designs from Maxim for DC-DC Converter schematics only.

A list of sample designs appears by name, type, and part number. Click a column name in the heading row to sort the list. The following additional details appear:

- **Vin-min:** The minimum input voltage.
  - **Vin-max:** The maximum input voltage.
  - **Vout:** The output voltage.
  - **Iout:** The output current.
  - **# Outputs:** The number of outputs in the design.
4. Click anywhere in the row of the reference design you want to open.

**NOTE:** The original reference design cannot be changed. You are opening a copy of the design, similar to a template.

5. Adjust the schematic only as required. Remember, when working with a valid reference design, making too many edits can defeat the very purpose behind building new designs based on a reference design.
6. Click **Save**.

## 3 DC-DC Converter Designs V2 (Beta)

**ALERT:** A new version (V2) of the DC-DC Design Tool is in Beta test. This chapter describes V2. For help with the previous version of the DC-DC Design Tool (V1), refer to Chapter 4: DC-DC Converter Designs V1.

The part number chosen determines whether V1 or V2 is used. Parts identified with a purple asterisk (\*) on the New tab are available in V2. Parts without a purple asterisk remain in V1.

NOTE: "Beta" is displayed in the upper right corner of the tool instead of "DC-DC" when V2 is running.

As a registered member of the Maxim Integrated online community, use the Maxim EE-Sim DC-DC Converter tool to design, modify, simulate, analyze, and purchase a variety of power solutions, including step-up, step-down, and isolated configurations.

This tool automatically creates a circuit schematic and bill of materials (BOM) based on your requirements, saving precious design time and resources. Set up and complete simulations in just minutes without having to learn the complexities of the simulator. Take advantage of the following additional features:

- Share designs with colleagues.
- Order a BOM from your distributor of choice.
- Print a complete report with annotated schematics and custom simulation graphs.
- Download a free version of the EE-Sim Simulation Engines (EE-Sim SE) for more detailed and flexible simulation capabilities.
- Download a copy of your design from the DC-DC converter tool for use with EE-Sim SE.

### 3.1 Open an Existing Design

Open one of your existing designs or a pre-designed template from Maxim.

1. Click the **My Designs** tab to open a saved design.
2. For DC-DC Converters only, click the **Maxim Designs** tab to open one of the pre-designed schematics available from the engineers at Maxim. These designs represent circuits designed, built, and tested in a laboratory environment.
3. You may be prompted by the message below:





- a. Click **Cancel** to ignore your last selection and return to the previous page.
- b. Click **Return to Current Design** to see where you were last working. If the design is valid, keep working on it, click **Save**, and name that design. If the design was not worth saving, simply load the new design.
- c. Click **Load New Design** to discard the previous current design and start a new one.

**NOTE:** You may not be aware that you have another design open, known as the *current design*. The current design is simply the last design you were working on and the tool remembers it so you can go back to it with ease. When in doubt, click **Return to Current Design** to check on your work and save it to keep it. If the current design does not need to be saved, click **Load New Design** with confidence.

## 3.2 Create a New Design

Use the EE-Sim environment to create an unlimited number of new designs. After entering your detailed input requirements, generate an interactive schematic with components you can modify.

1. Open a web browser and navigate to [www.maximintegrated.com/ee\\_sim/](http://www.maximintegrated.com/ee_sim/).
2. Click **Start the EE-Sim tool** or **Login if you are a returning user**.
3. If you are logged in, skip ahead to the next step. If you are not logged in automatically, complete the **Member Login** page:
  - a. In the **E-mail Address** field, enter the e-mail address that you used when you registered.
  - b. In the **Password** field, enter your password for your Maxim account.
  - c. Click the **Log Me In** button.
  - d. On the **Login Successful** page, click **Start the EE-Sim tool**.
4. On the **New** tab, select **DC-DC Converters**.
5. Expand the **Browse All Power ICs** section:
  - a. Click the **+** icon to expand a product category to view a list of Maxim products.
  - b. Click a part number to create a new design based on that part.
  - c. (Optional) Click the document icon  to view additional product information including an overview, product data sheet, design resources, and ordering details.
6. (Optional) Instead of browsing all power ICs, expand the **Parametrically Select a Switch-Mode Power Supply IC** section to select a part based on your criteria:
  - a. Enter an input voltage range and specify up to two outputs.
  - b. Select the converter type and features you need.
  - c. Search, sort, and browse the list of matching converters in the **Choose Converter** section.
  - d. Click a part number to create a new design based on that part.
7. The **Design Requirements** page appears. Your selected part number is displayed in the upper left corner.  
For example:

**Part Number:** MAX17598   
**Design Name:** Save Design
8. (Optional) To view a PDF datasheet, click the PDF document icon for the part.
9. Continue to the next topic to specify your design requirements.

## 3.3 Specify Input, Output, and Other Design Requirements

All design requirements are set to default values when a new design is opened. Use this procedure to edit those values before generating a new schematic.

1. On the **Design Requirements** page:
  - a. In the **Input Requirements** section, enter your input values in each field.
  - b. In the **Output Requirements** section, enter your output values in each field.
  - c. In the **Design Priorities** section, specify the cost and performance considerations that you want to emphasize in the **Performance Tradeoff** and **Cost Tradeoff** fields. Choose to optimize your design for efficiency or small size, or even to balance the design between both factors. For cost trade-offs decide between higher performance and lower cost.
  - d. In the **Design Criteria** section, enter your settings in each field.
2. If available, click **Show Advanced** to view additional requirements. Click **Hide Advanced** to hide the additional requirements and simplify the current page.

**NOTE:** The sections and fields that appear can vary by part. Also be aware that hidden advanced requirements are still used in the design even though you can choose not to show them in your current browser window.

3. Apply any of the following tips to save time and improve accuracy:
  - a. Press the **Tab** key to move to the next field.

- b. Verify that the values entered are in the correct field and in the required units.
- c. Position the mouse pointer over a field to see a tooltip. For example, the tip might show the acceptable minimum and maximum values for a specific field.
- d. In Internet Explorer 10 and 11, click the small **x** to clear the value of a field.
- e. In fields that require a limited set of acceptable values, enter a value using any of the following methods:
  - Click the  drop-down menu icon and choose a value.
  - Enter the first digit of the closest matching value.
  - Press the **Tab** key to enter the field, then press the **Up** or **Down** arrow keys.
4. A message appears if your entry is not acceptable. The tool automatically reverts to the last acceptable value. Read the on-screen tip and adjust the value as advised.
5. (Optional) Click the **Restore Defaults** button to revert all fields back to their original values.
6. Continue to the next topic to generate a schematic.

## 3.4 Create a Schematic and Save Your Design

In the two previous procedures, you selected a part to create a new design and entered your design requirements. Follow these steps to generate a schematic that meets those requirements and save a new design.

1. When all your values have been entered on the **Design Requirements** page, click **Create Design**.
2. The EE-Sim tool performs a complex set of calculations to design a circuit that meets your requirements. The tool selects commercially available components to satisfy your design requirements, and a visual representation of your design appears on the **Schematic** page. Click the **Save** button or the **Save Design** link to save your design. In the **Save Your Design** window:
  - a. In the **Design Name** field, enter a unique name to differentiate this design from your other designs as well as the shared designs of other users.
  - b. In the **Design Description** field, enter a short description of the design to remind you later of its purpose. The description is also helpful for any recipients if you decide to share the design.
  - c. Click **Save**.

## 3.5 Next Steps

Congratulations! You generated a schematic and saved your design. You can now perform one or more of the following tasks:

Task:	Step:	Learn More:
Adjust your design requirements:	Click the <b>Design Requirements</b> tab to change the design requirements, then click <b>Create Design</b> to generate a new schematic. A new version of the design is added to the History.	<i>Specify Input, Output, and Other Design Requirements</i>
Run simulations:	Click the <b>Schematic</b> tab and click <b>Simulation</b> .	<i>3.7 Simulation and Analysis</i>
Edit your schematic:	Click the <b>Schematic</b> tab.	<i>3.6 Edit a Schematic</i>
Compare design versions:	Click the <b>Compare</b> tab.	<i>3.8 Compare Design Iterations</i>
View a summary report of your design and download a BOM:	Click the <b>Report</b> tab and perform any of the available options.	<i>3.9 Generate a Design Report and BOM (DC-DC)</i>
Download your designs:	Click the <b>Download</b> tab and perform any of the available options.	<i>8.4 Download a Schematic</i>





**NOTE:** Although there is an implied left to right sequence among the application tabs, you are not required to visit every tabbed page. For example, you could click the **Report** tab to generate a report without running any simulations and without viewing the **Compare** tab.

## 3.6 Edit a Schematic

### 3.6.1 Edit Component Properties

Change the properties of the components in your schematic as described below. Some components are considered *critical* to the design and other parts are not. When adjusting critical component values, the application flags them for your attention by applying a highlight color to both the component you changed and the **Recalculation** button. This change in appearance alerts you to edits that impact the values in other components. These impacted values can be recalculated.

1. Open a design and click the **Schematic** tab.
2. To adjust the basic visual settings of parts, including fill color, line color, dash, and width, right-click a line or component and adjust the settings available in the pop-up menus. Define custom colors by their RGB, HSB, or hexadecimal values.
3. Double-click a component to open it, or right-click a component and choose **Properties**.
4. In the **Edit Properties** window:
  - a. Click **+** to expand a section to view its available properties. Click **-** to collapse a section.
  - b. For critical components, observe the appearance of the following message:  
 **This is a critical component. Changing values might require a re-calculation.**  
Changing a critical component can substantially alter the performance of the circuit. After changing critical component values, recalculation is recommended.
  - c. For critical components, observe the appearance of the  **Unlocked** message. Lock a critical component to prevent its values from changing later when you click **Recalculation**. Click the checkbox to toggle this setting between **Locked** and **Unlocked**.
  - d. In the **Component Information** section locate the **Part Data** field. Click **User-Defined** to set your own custom component parameter values or click **Vendor** to view the currently selected component. Click **Select Vendor Part** to view a list of other parts that meet your filter criteria. To learn more, see 3.6.2 Select a New Vendor Part.
  - e. Click **Apply**.
5. Continue editing the schematic as necessary. After editing a critical component, the **Recalculation** button and the critical component changed appear in an orange color.
6. When edits are complete, click **Recalculation**. A warning message appears to advise that unlocked component values might change. To continue with the recalculation, click **Yes**. To go back and adjust which components are locked and unlocked, click **No**.
7. After performing a recalculation, evaluate the design changes by observing the schematic or use the **Compare** tab to see a list of differences between the current version of the design and any prior versions in the history. Continue to adjust the values and recalculate as often as needed.
8. Click **Save** when complete.

**NOTE:** Each time you recalculate, a new version of your schematic is added to the version history for the current design.

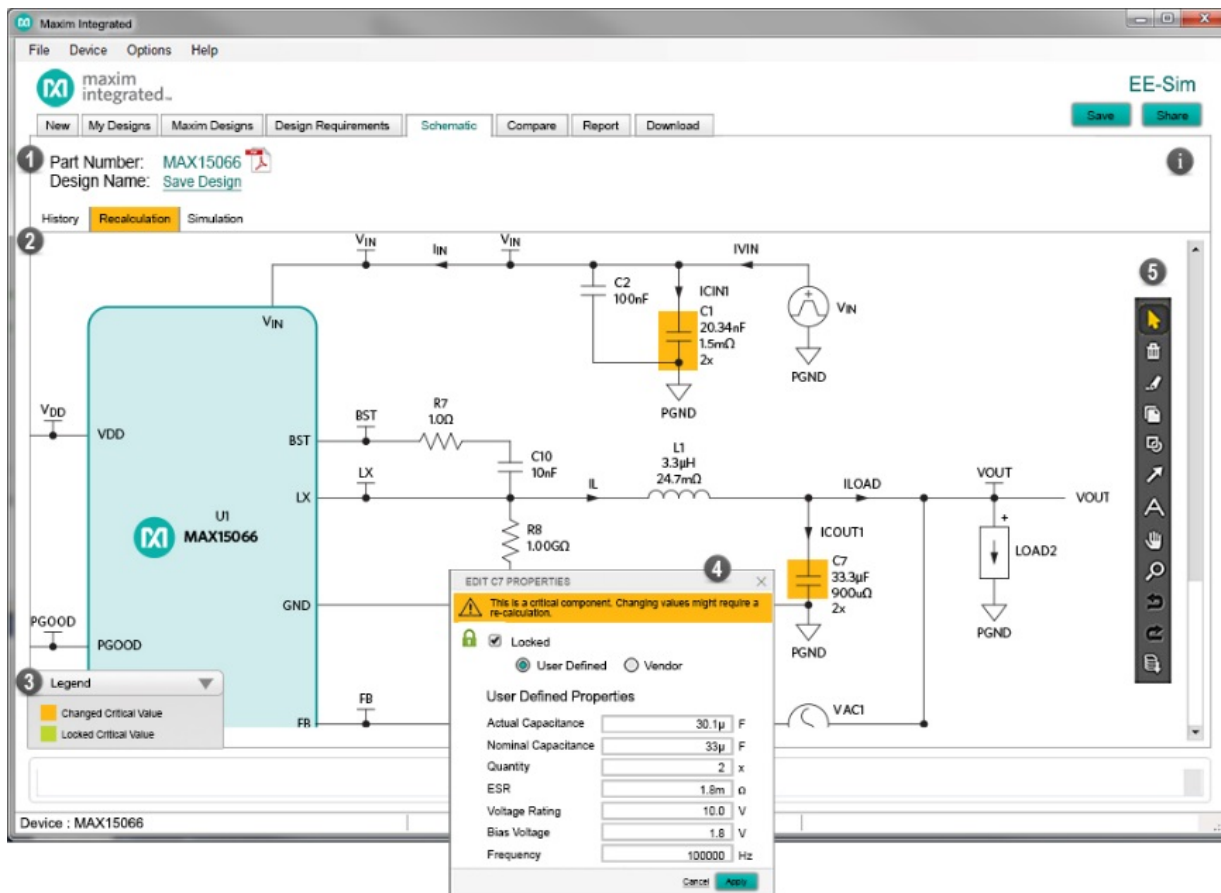

- 1 Click the part number or PDF icon to view the data sheet. Click **Save Design** or the **Save** button at right to save your new design.
- 2 When the **Recalculation** tab is highlighted, click it to perform adjustments to your schematic based on pending changes you made to critical components.
- 3 As the **Legend** reminds you, critical components with changes are flagged in the diagram in orange (C1). Critical components with locked values appear in green (L1). Critical components that have been changed and are locked appear in both colors (C7).
- 4 Double-click or right-click a component to edit its properties or change vendors. Critical components feature an orange banner at the top of the properties window. A component shows its locked or unlocked state with a checkbox on the properties window and a padlock icon that appears in the locked or unlocked state.
- 5 Use the new schematic toolbar to apply annotations, zoom and pan, and export the schematic image.

### 3.6.2 Select a New Vendor Part

Component values, secondary parameters, and even specific manufacturer part numbers for most components in the schematic can be changed. Choose from a library of appropriate purchasable components or just supply the key values for a component without selecting a purchasable part.

1. Open a design and click the **Schematic** tab.
2. Double-click a component to open and edit it, or right-click a component and choose **Properties**. In the example shown below, the C2 capacitor from a MAX 15066 design is opened in the schematic diagram.
3. In the **Edit Properties** window:
  - a. If it is not already expanded, click + to expand **Component Information**.
  - b. In the **Part Data** field, choose **Vendor Part** to view the chosen manufacturer and part number.

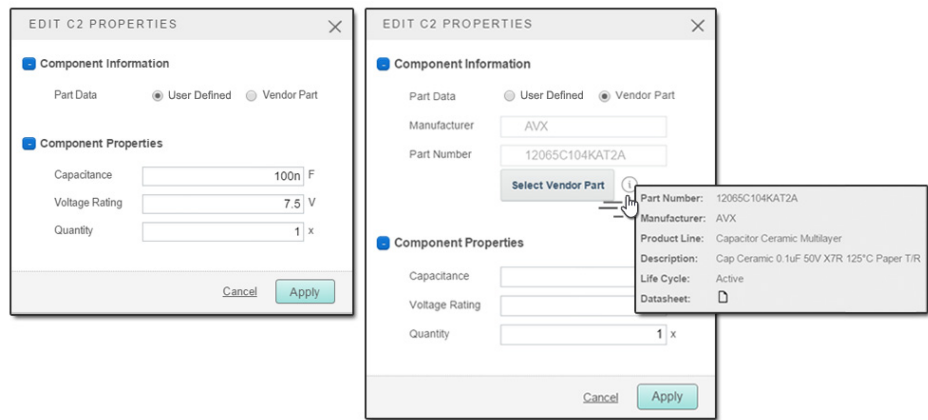

- c. Click the **Select Vendor Part** button to view a list of other parts that satisfy the requirements for this design. Also visible are the filter settings used to select these parts from the part database.
- d. Search for a different part by modifying one or more filters to search for the required manufacturers, attributes, and products.
- e. Click **APPLY FILTERS** to view a list of potential matching parts. To learn more, click the link below a part. When ready to select a different part, click the entry to swap the old part for the new one.
- f. Review the fields in the **Component Properties** section. For example, **Capacitance**, **Voltage Rating**, and **Quantity**.
- g. Click **Apply**.

Applying filters to select a different vendor part is demonstrated in the graphic on the next page.

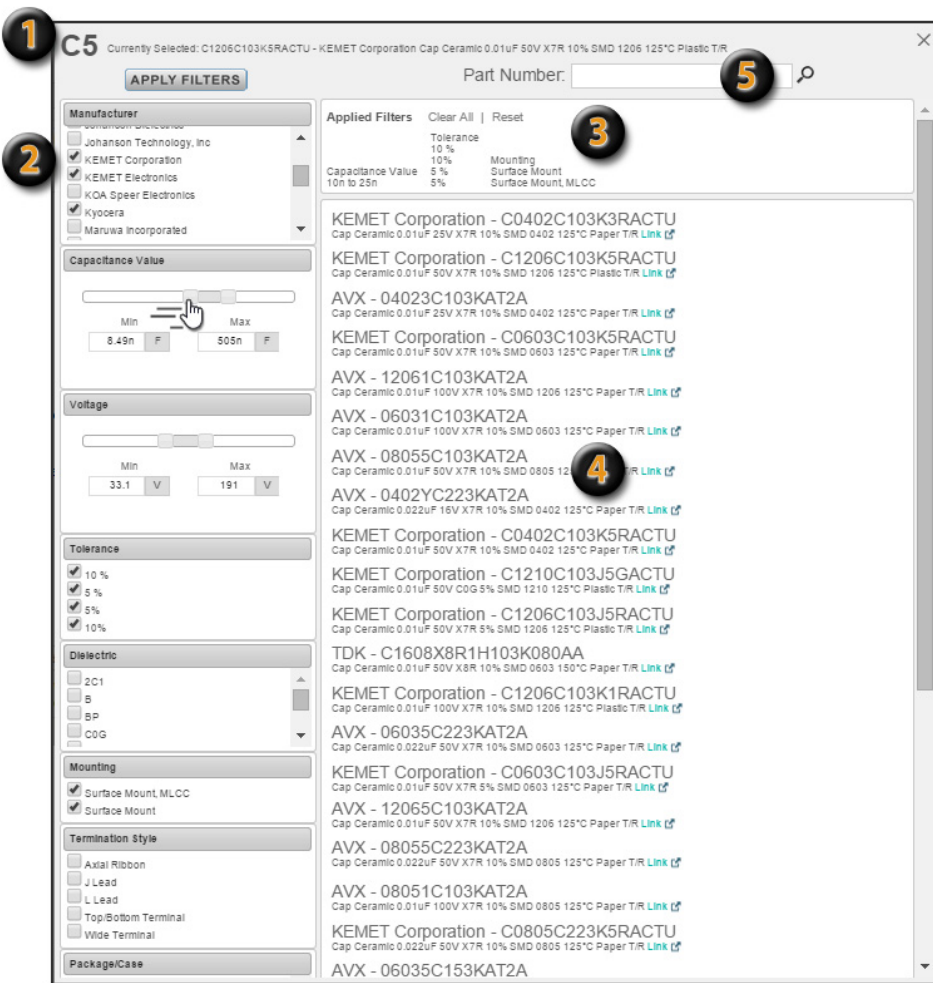

- 1 Selected Part:** The top of the window shows the currently selected part.
- 2 Available Filters:** This section lists search options. Default settings are based on the design requirements that you entered for your design before generating the schematic and best practices for this part as determined by Maxim's applications engineers. If changes are made to the filter settings such as widening a filter, you can get parts that no longer satisfy the needs of the circuit. Do so with care and proper circuit design knowledge. For items with sliders, either move the sliders or modify the data in the boxes at either end of the sliders. After making any changes to the filter settings, click the **Apply Filters** button to find the parts that match your newly modified criteria. Click **Reset** to restore default values and **Clear All** to remove all values, which allow you to start the filtering process *from scratch*.
- 3 Applied Filters:** This section reminds you of the search criteria used to generate the current list of matching parts.
- 4 Results:** Click **Link**  for a part number to learn more about the product and manufacturer. Click on the part number or description to replace the currently selected part with this new one.
- 5 Search:** Search for a specific component (filters are not applied).

### 3.6.3 Annotate a Schematic Using the Toolbar

Use the convenient toolbar to annotate, markup, adjust the view, resize, or export an image of your schematic.

- 1.** Open a design and click the **Schematic** tab.
- 2.** To adjust the basic visual settings of parts, including fill color, line color, dash, and width, right-click a line or component and adjust the settings available in the pop-up menus. Define custom colors by their RGB, HSB, or hexadecimal values.
- 3.** To select specific components and adjoining lines in the schematic, click  **Select Items**. For example, change the line and fill colors or export an image of a selected item. This standard









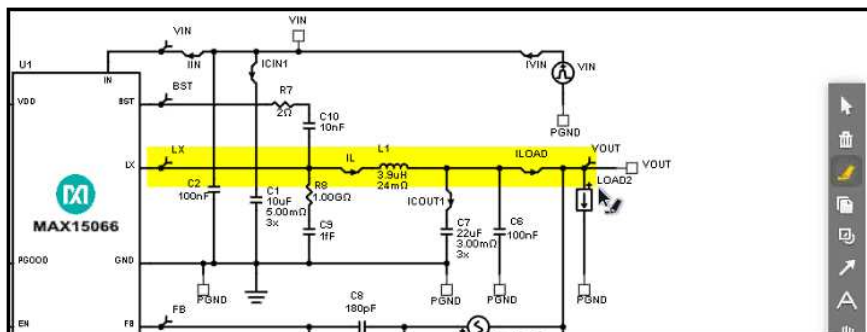

mouse pointer is the default toolbar button setting. To select multiple components at the same time, click down once and drag a box around multiple parts.

- To delete a specific shape, text, highlighted area, or other annotation, click  **Delete Items**. Position the pointer with the small trash can over the annotation items you want to delete and click each one to remove them.

**Tip:** Click **Undo** if you accidentally delete an item and want to restore it. Circuit components are protected, and cannot be deleted.



- To highlight an area of interest (for example, a high-current path), click  **Draw Highlight**, then mark up a specific section in your design by clicking and dragging. An example appears below:



- To copy the schematic as an image click  **Copy Image to Clipboard**. Paste the schematic image to another application such as Word or PowerPoint.
  - Click  **Copy Schematic Window Image to Clipboard** to take the current view adjustments made to the schematic into consideration. Only the portion of the schematic that fits within the current browser window is copied.
  - Click  **Copy Complete Schematic Image to Clipboard** to ignore any custom view adjustments (zoom, pan). The entire schematic is copied.
  - Either option generates a small .png file in your browser. Right-click the image and save the file to your computer or copy the image to your computer's internal clipboard. To paste the image, click Paste-Special and choose Device Independent Bitmap.
  - Click **Close**.
- To draw a circular or rectangular shape around one or more components, click  **Shape Tools**. Then, specify the type of shape you want to add (  **Draw Ellipse** or  **Draw Rectangle**). Click and drag directly on the schematic to draw a circle, oval, rectangle, or square shape. To insert text, double-click the shape outline. Right-click the shape to change the font and colors.
- To draw arrows in the schematic, click the  **Draw Arrow** tool.
- To annotate the schematic with a short custom text block, click  **Text Box**.
  - Click the area of the design where you want the text to appear.
  - In the resulting **INPUT TEXT** box, type your custom text and click **Apply**.
  - Right-click a text box to change the font and colors.
- To adjust the position of the schematic in your browser window, click  **Pan**. Click and hold down the mouse button to drag the schematic in any direction.
- To adjust the magnification of the schematic, click  **Zoom Tools**. From left to right, zoom options include:
  - Reset Zoom:** Click this option to restore the original magnification to the default zoom of 100%.
  - Zoom to All Components:** Click this option to magnify the view in or out to a standard size that fits all components into the available view.

- **Zoom Out:** Reduces the magnification to view more components; however, they appear at a smaller size.
  - **Zoom In:** Increases the magnification to view fine details about specific components; however, zooming in shows fewer components.
  - **Area Zoom Tool:** Define a box around a particular component or set of components to zoom in on a precise area.
12. To step back in time and undo the last action that you applied to the schematic, click  **Undo Last Action**. Use this command to erase unwanted edits such as components that you accidentally added, moved, adjusted, or deleted. When the command is not available, the icon is grayed out to indicate that there is no recent action to undo.









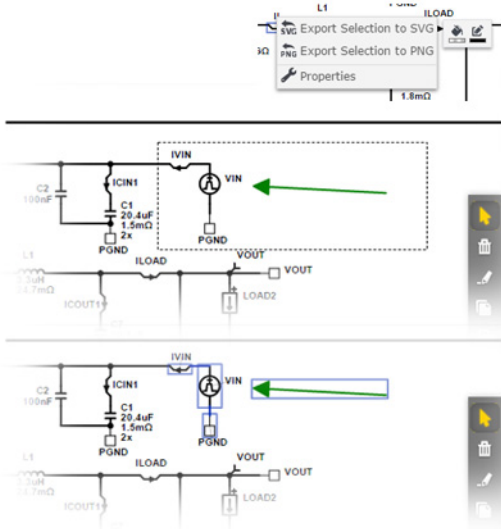

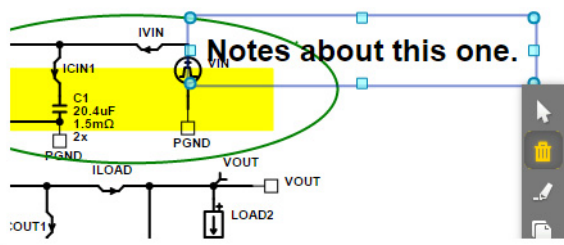
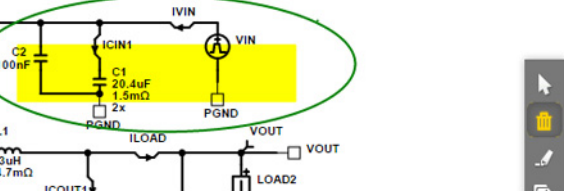

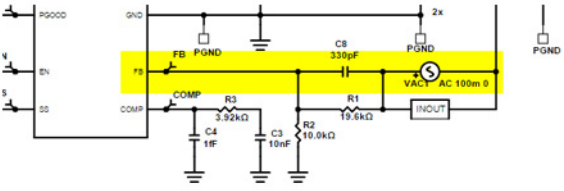
**NOTE:** Some actions cannot be undone. For example, if you resize a text box, you cannot undo this action by clicking Undo. Instead, resize the text box again.

13. To reverse an **Undo** command, click  **Redo Last Action**. When the command is not available, the icon is grayed out to indicate that there is no recently undone action to redo.
14. To export an image of the schematic, click  **Export Schematic Image**. Select one of the following image formats, then click **Export File**:
- Bitmap (BMP)
  - JPEG (JPG or JPEG)
  - Portable Network Graphics (PNG)
  - Scalable Vector Graphics (SVG)
  - Tagged Image File Format (TIF or TIFF)
  - Windows Metafile (WMF)

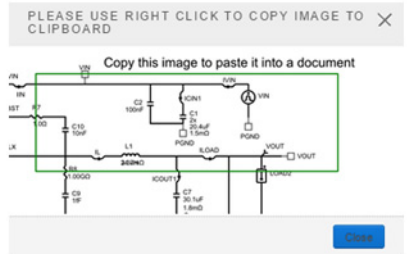
### 3.6.4 Schematic Toolbar Reference Chart

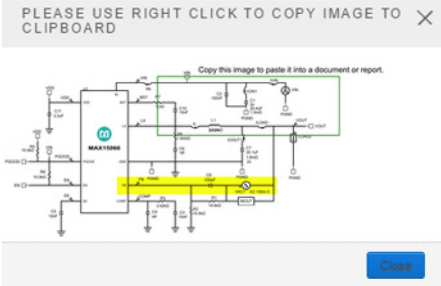
Refer to the following examples when working with the schematic toolbar.

Toolbar Button:	Function:	Examples:
 <p><b>Select Items</b></p>	<p>Selects components, annotations, and groups of both (multi-select inside a screen area that you define).</p> <p>Standard mouse pointer used for right-clicking components and annotations to set properties.</p> <p>Can also be used to click an annotation to select it and press the <b>Delete</b> key to remove the item.</p>	 <p>The examples show a schematic diagram with various components like capacitors (C1, C2), inductors (L1), and a current source (VIN). The top example shows a context menu with options like 'Export Selection to SVG' and 'Export Selection to PNG' after a right-click. The bottom example shows a blue selection box around a component, with a green arrow pointing to the 'Select Items' toolbar button.</p>

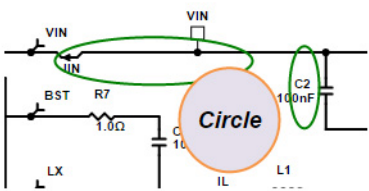
Toolbar Button:	Function:	Examples:
 Delete Items	Deletes the selected annotation item. In this example, custom text notes are deleted.	 
 Draw Highlight	Highlights an area in the schematic.	
 Copy Image to Clipboard	Expands to show two options for copying the current schematic.	
 Copy Schematic Window Image to Clipboard	Copies only the portion of the schematic that is visible in the window.	
 Copy Complete Schematic Image to Clipboard	Copies the entire schematic.	
 Shape Tools	Shows the options for drawing shapes.	
 Draw Ellipse	Draws an oval or circle.	

Toolbar Button:      Function:      Examples:

 Draws a rectangle or square.

**Draw Rectangle**

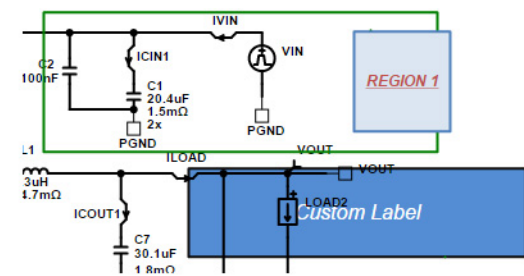

 Draws an arrow.

**Draw Arrow**



 Allows you to enter text. When you click Apply, the text is inserted in the schematic.

**Text Box**

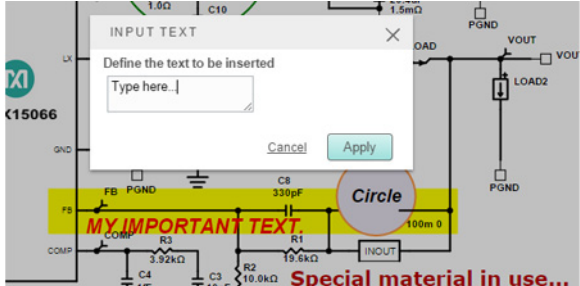

 Moves the schematic up, down, left, or right.

**Pan**

Tip: After you zoom in, pan the image to pinpoint specific regions.

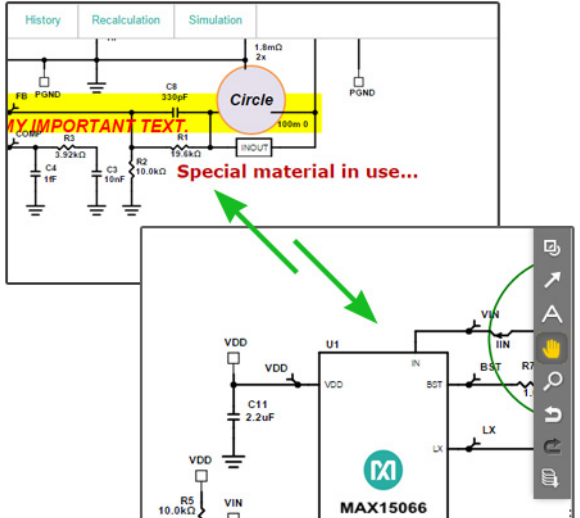

 Expands to show the view magnification (zoom) options.

**Zoom Tools**







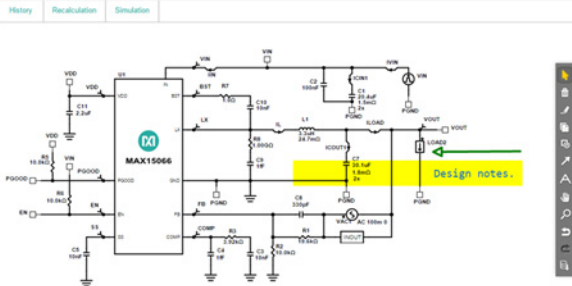



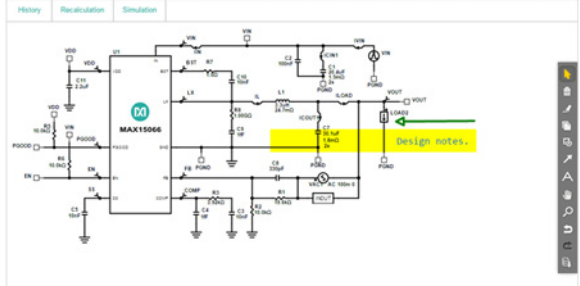

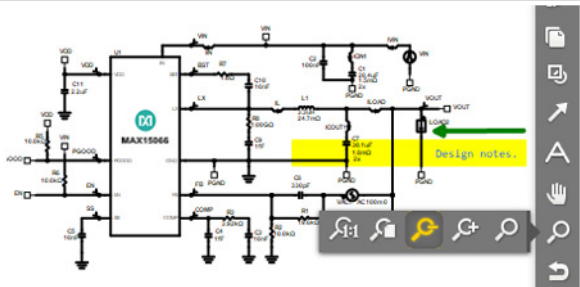

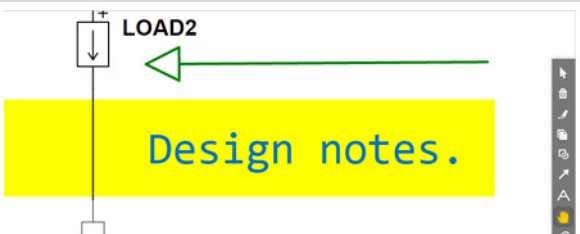
 Resets any previous zoom settings and restores the default view.

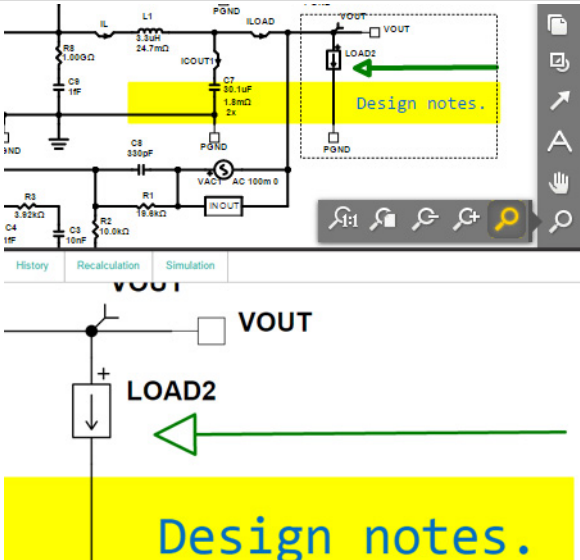
**Reset Zoom**



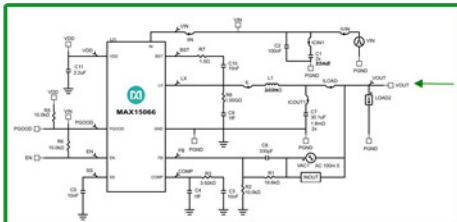

Toolbar Button:	Function:	Examples:
 <b>Zoom to All Components</b>	Fits the entire schematic onto the current page. The image appears smaller because all components are included.	
 <b>Zoom Out</b>	Zooms out one level. With each click, the image appears smaller because the view is relative to a point that is going out, away from the schematic.	
 <b>Zoom In</b>	Zooms in one level. With each click, the image appears larger because your view is relative to a point that is going in, closer to the schematic.	
 <b>Area Zoom Tool</b>	Defines an area in the schematic, then magnifies it (zooms in) to show as much of it as possible in the current view.  In this example, the user defines the rectangle around the Design notes text and arrow (top) with the Area Zoom Tool before it expands (bottom).	
 <b>Undo</b>	Reverses the last action. This command is not always available.	
 <b>Redo</b>	Reverses the last undone action. This command is not always available.	

Toolbar Button:	Function:	Examples:
	Choose an image format for exporting the schematic to an image file. Import the image file to Word, PowerPoint, and other applications.	 
		

### 3.6.5 Version History

The DC-DC Converter Design V2 tool automatically stores versions of your design as you work. Changes in design requirements and recalculated schematics trigger a new major version; changes in device values are recorded as minor versions.

While working on your design, you can go back at any time and retrieve any of these versions with all their values and simulation results preserved. When you save your design, all versions of the design are also saved with it.

**NOTE:** Although simulation data is not saved when you exit your design, having all versions of the design saved enables you to rerun simulations if needed. Knowing your designs are saved with such an audit trail enables you to work with confidence.

1. Open a design and click the **Schematic** tab.
2. Click **History**.
3. Review the list of schematic versions. For example, from the bottom of the list to the top, you might see the following:

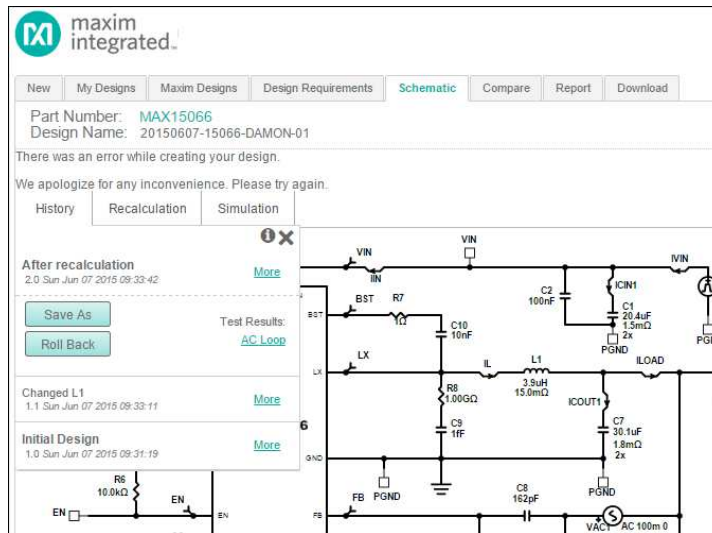

- a. The *Initial Design* identified by the major version 1.0 with the original creation date and time.