



Chipsmall Limited consists of a professional team with an average of over 10 year of expertise in the distribution of electronic components. Based in Hongkong, we have already established firm and mutual-benefit business relationships with customers from,Europe,America and south Asia,supplying obsolete and hard-to-find components to meet their specific needs.

With the principle of “Quality Parts,Customers Priority,Honest Operation,and Considerate Service”,our business mainly focus on the distribution of electronic components. Line cards we deal with include Microchip,ALPS,ROHM,Xilinx,Pulse,ON,Everlight and Freescale. Main products comprise IC,Modules,Potentiometer,IC Socket,Relay,Connector.Our parts cover such applications as commercial,industrial, and automotives areas.

We are looking forward to setting up business relationship with you and hope to provide you with the best service and solution. Let us make a better world for our industry!



Contact us

Tel: +86-755-8981 8866 Fax: +86-755-8427 6832

Email & Skype: info@chipsmall.com Web: www.chipsmall.com

Address: A1208, Overseas Decoration Building, #122 Zhenhua RD., Futian, Shenzhen, China



MAXIM

MAX1848 Evaluation Kit

Evaluates: MAX1848

General Description

The MAX1848 evaluation kit (EV kit) is a fully assembled and tested circuit board that contains a step-up switching-regulator current source powering three series-connected white LEDs. The circuit provides programmable LED current. The EV kit can be powered from a 2.6VDC to 5.5VDC source.

The MAX1848 features programmable soft-start and LED brightness control. The MAX1848 EV kit demonstrates matching LED brightness with high converter efficiency (87%) to maximize battery life. Operation at 1.2MHz allows the use of tiny surface-mount components.

Features

- ◆ >87% Efficiency
- ◆ 2.6V to 5.5V Input Voltage Range
- ◆ Analog LED Intensity Control
- ◆ Drives Up to Three Series White LEDs with Uniform Brightness
- ◆ Small, Low-Profile External Components
- ◆ 0.3 μ A IC Shutdown Current (typ)
- ◆ 1.2MHz Switching Frequency
- ◆ 8-Pin SOT23 Package
- ◆ Fully Assembled and Tested

Component Suppliers

SUPPLIER	PHONE	FAX
Central	631-435-1110	631-435-1824
Murata	770-436-1300	770-436-3030
Taiyo Yuden	800-348-2496	847-925-0899

Note: Please indicate that you are using the MAX1848 when contacting these component suppliers.

Ordering Information

PART	TEMP RANGE	IC PACKAGE
MAX1848EVKIT	0°C to +70°C	8 SOT23

Component List

DESIGNATION	QTY	DESCRIPTION
C1	1	3.3 μ F, 6.3V X5R ceramic capacitor (0805) Taiyo Yuden JMK212BJ335MG
C2	1	1.0 μ F, 16V X5R ceramic capacitor (0805) Taiyo Yuden EMK212BJ105KG
C3	1	0.22 μ F, 10V X7R ceramic capacitor (0603) Taiyo Yuden LMK107BJ224KA
C4	1	1000pF, 50V X7R ceramic capacitor (0603) Taiyo Yuden UMK107B102KZ
D1	1	0.2A, 30V high-speed switching diode (SOD-323) Central Semiconductor Corp. CMDSH2-3

DESIGNATION	QTY	DESCRIPTION
D2, D3, D4	3	Right angle white LEDs (SMD 2.8mm x 1.2mm x 1mm)
L1	1	47 μ H, 170mA inductor (low cost) Murata LQH3C470K34 33 μ H (optimum performance)
R1	1	4.99 Ω \pm 1% resistor (0805)
U1	1	MAX1848EKA (8-pin SOT23)
None	1	MAX1848 PC board
None	1	MAX1848 data sheet
None	1	MAX1848 EV kit data sheet



MAX1848 Evaluation Kit

Quick Start

The MAX1848 EV kit is fully assembled and tested. Follow these steps to verify board operation. **Do not turn on the power supply until all connections are completed.**

Recommended Equipment

- One voltmeter
- Dual power supply 5V, 1A

Main Output

- 1) Connect a voltmeter to the VOUT pad.
- 2) Make sure both power supplies are set to 0V and off before connecting the power supplies to the circuit.
- 3) Connect a 5V supply to the VIN pad. Connect the power-supply ground to the GND pad.
- 4) Connect a 5V supply to the VCTRL pad. Connect the power-supply ground to the GND pad.
- 5) Turn on the VIN power supply and set it to 3.3V.
- 6) Turn on the VCTRL power supply, vary the VCTRL between 0 and 2V and observe the variation in brightness of the LEDs.
- 7) Verify that the output, VOUT is approximately 10V when the VCTRL power supply is 2V.
- 8) Vary the VIN power supply from 2.6V to 5.5V and verify that the LED brightness remains constant.
- 9) Verify that the LEDs are off when VCTRL drops below 100mV.

Detailed Description

The MAX1848 EV kit contains a switching-regulator current-source circuit. The EV kit's circuit is configured to drive three series-connected LEDs. The EV kit can be powered by a 2.6V to 5.5V DC source.

The MAX1848 EV kit features programmable LED brightness by controlling LED current, overvoltage protection, and up to 87% efficiency for maximum battery life.

Soft-Start

The soft-start feature limits the inrush current during startup. Capacitor C3 determines the startup delay time for the EV kit. The delay time for the EV kit is set to 18.3ms.

The following equation can be used to configure the EV kit for other startup times:

$$t = (C3) \times (1V) / (12\mu A)$$

where

t = desired startup time delay

LED Current

The current through the LEDs is related to the current-sense resistor (R1) by the following equation:

$$I_{LED} = V_{CTRL} / (13.33 \times R1)$$

Adjusting the control voltage VCTRL varies the intensity of the LEDs. VCTRL can range from 250mV to 5.5V or (VIN + 2V), whichever is lower. However, with R1 = 4.99Ω, VCTRL should not exceed +2V in order to keep the LED current below its absolute maximum rating of 30mA.

Shutdown

The MAX1848 enters shutdown mode when VCTRL drops below 100mV. In shutdown mode, the MAX1848 quiescent current is reduced to 0.3μA. The MAX1848 comes out of shutdown mode when VCTRL rises above 250mV.

Overvoltage Protection

Overvoltage protection occurs when VOUT is above 13.25V (typ). The EV kit comes out of the overvoltage protection when VOUT falls below 12.25V (typ). This protects the MAX1848 and white LEDs during a fault condition.

MAX1848 Evaluation Kit

Evaluates: MAX1848

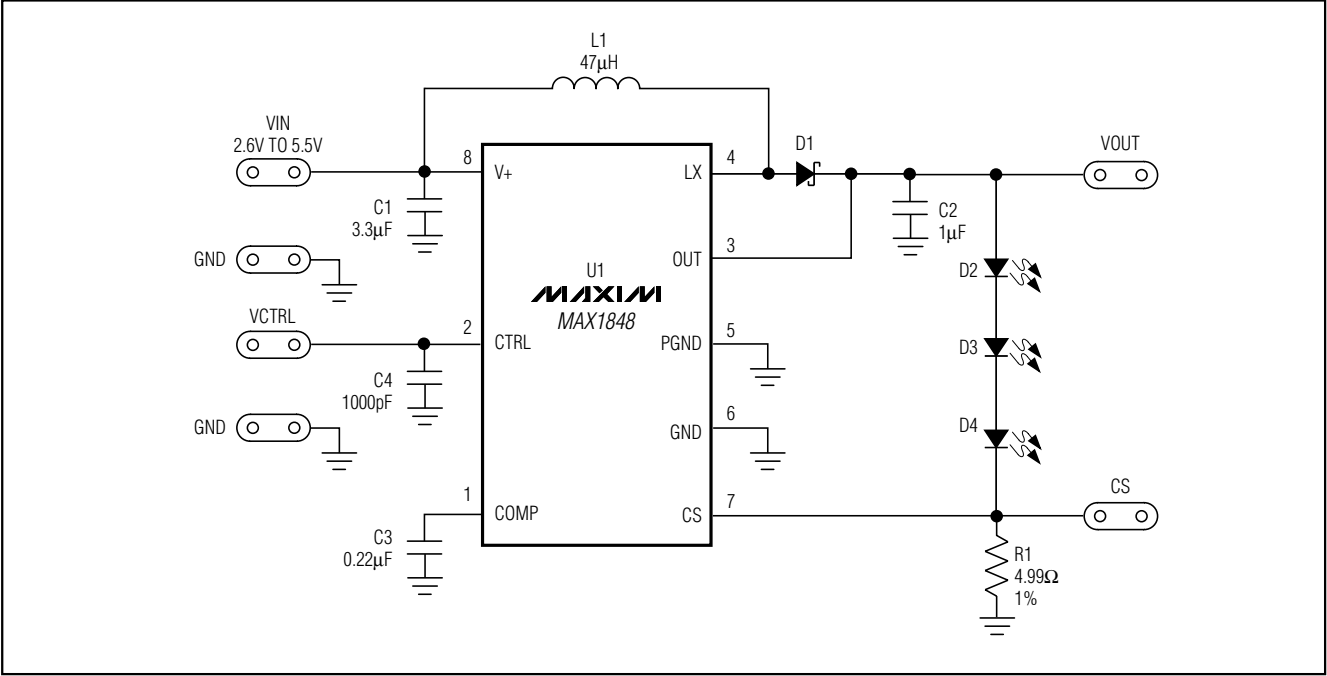

Figure 1. MAX1848 EV Kit Schematic

MAX1848 Evaluation Kit

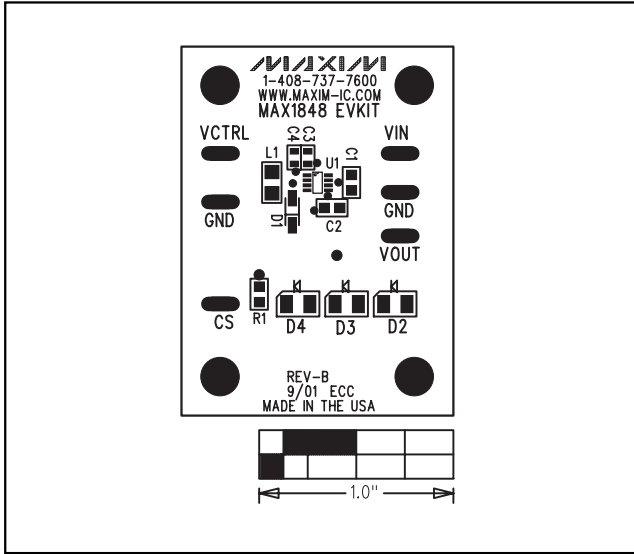

Figure 2. MAX1848 EV Kit Component Placement Guide—Component Side

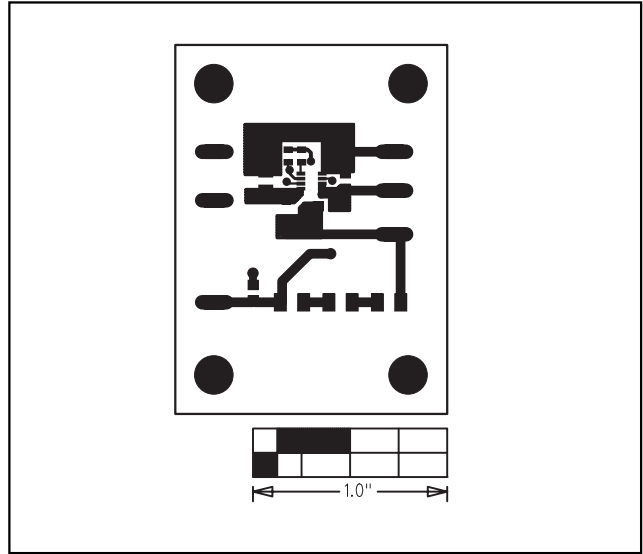

Figure 3. MAX1848 EV Kit PC Board Layout—Component Side

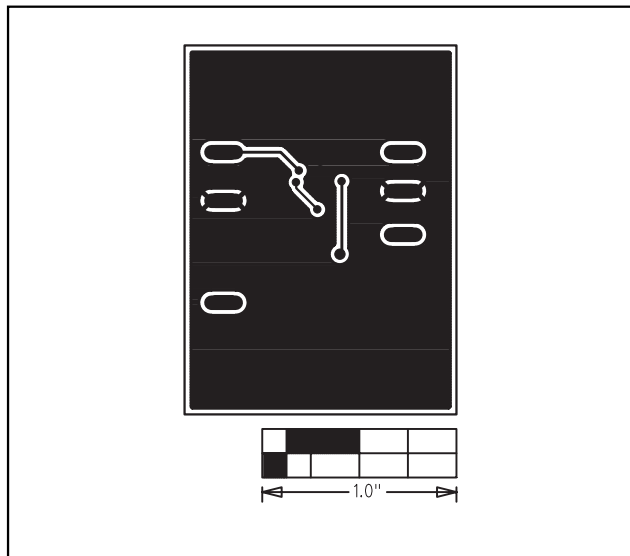

Figure 4. MAX1848 EV Kit PC Board Layout—Solder Side

Maxim cannot assume responsibility for use of any circuitry other than circuitry entirely embodied in a Maxim product. No circuit patent licenses are implied. Maxim reserves the right to change the circuitry and specifications without notice at any time.

4 _____ **Maxim Integrated Products, 120 San Gabriel Drive, Sunnyvale, CA 94086 408-737-7600**