



Chipsmall Limited consists of a professional team with an average of over 10 year of expertise in the distribution of electronic components. Based in Hongkong, we have already established firm and mutual-benefit business relationships with customers from,Europe,America and south Asia,supplying obsolete and hard-to-find components to meet their specific needs.

With the principle of "Quality Parts,Customers Priority,Honest Operation,and Considerate Service",our business mainly focus on the distribution of electronic components. Line cards we deal with include Microchip,ALPS,ROHM,Xilinx,Pulse,ON,Everlight and Freescale. Main products comprise IC,Modules,Potentiometer,IC Socket,Relay,Connector.Our parts cover such applications as commercial,industrial, and automotives areas.

We are looking forward to setting up business relationship with you and hope to provide you with the best service and solution. Let us make a better world for our industry!



## Contact us

Tel: +86-755-8981 8866 Fax: +86-755-8427 6832

Email & Skype: info@chipsmall.com Web: www.chipsmall.com

Address: A1208, Overseas Decoration Building, #122 Zhenhua RD., Futian, Shenzhen, China



# MAX1920/MAX1921

# Low-Voltage, 400mA Step-Down DC-DC Converters in SOT23

## General Description

The MAX1920/MAX1921 step-down converters deliver over 400mA to outputs as low as 1.25V. These converters use a unique proprietary current-limited control scheme that achieves over 90% efficiency. These devices maintain extremely low quiescent supply current (50µA), and their high 1.2MHz (max) operating frequency permits small, low-cost external components. This combination makes the MAX1920/MAX1921 excellent high-efficiency alternatives to linear regulators in space-constrained applications.

Internal synchronous rectification greatly improves efficiency and eliminates the external Schottky diode required in conventional step-down converters. Both devices also include internal digital soft-start to limit input current upon startup and reduce input capacitor requirements.

The MAX1920 provides an adjustable output voltage (1.25V to 4V). The MAX1921 provides factory-preset output voltages (see the *Selector Guide*). Both are available in space-saving 6-pin SOT23 packages. The MAX1920 is also available in a 6-pin TDFN package.

## Applications

- Next-Generation Wireless Handsets
- PDAs, Palmtops, and Handy-Terminals
- Battery-Powered Equipment
- CDMA Power Amplifier Supply

## Features

- 400mA Guaranteed Output Current
- Internal Synchronous Rectifier for > 90% Efficiency
- Tiny 6-Pin SOT23 Package
- Available in 6-Pin TDFN Package (MAX1920)
- Up to 1.2MHz Switching Frequency for Small External Components
- 50µA Quiescent Supply Current
- 0.1µA Logic-Controlled Shutdown
- 2V to 5.5V Input Range
- Fixed 1.5V, 1.8V, 2.5V, 3V, and 3.3V Output Voltages (MAX1921)
- Adjustable Output Voltage (MAX1920)
- ±1.5% Initial Accuracy
- Soft-Start Limits Startup Current

## Ordering Information

PART	TEMP RANGE	PIN-PACKAGE
MAX1920EUT-T	-40°C to +85°C	6 SOT23-6
MAX1920EUT+T	-40°C to +85°C	6 SOT23-6
MAX1920ETT-T	-40°C to +85°C	6 TDFN
MAX1920ETT+T	-40°C to +85°C	6 TDFN
MAX1921EUT__-T	-40°C to +85°C	6 SOT23-6
MAX1921EUT__+T	-40°C to +85°C	6 SOT23-6

**Note:** The MAX1921 offers five preset output voltage options. See the *Selector Guide*, and then insert the proper designator into the blanks above to complete the part number. +Denotes a lead-free package.

## Typical Operating Circuit

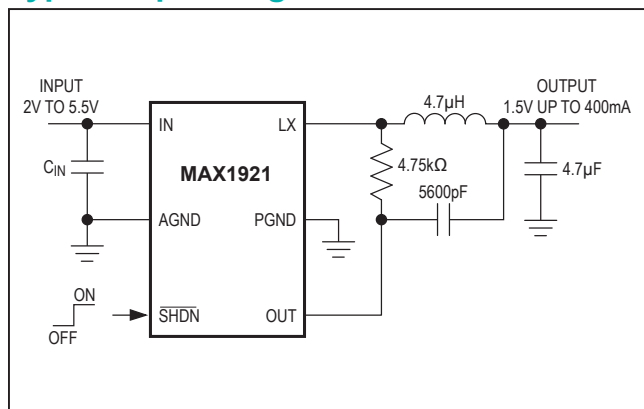

## Pin Configuration

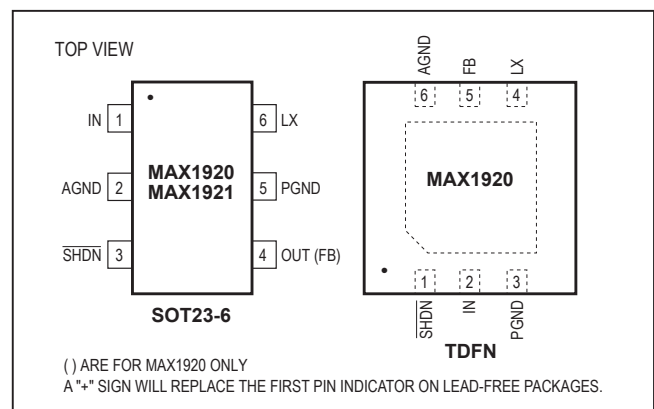



**Absolute Maximum Ratings**

IN, FB,  $\overline{\text{SHDN}}$  to AGND.....-0.3V to +6V  
 OUT to AGND, LX to PGND.....-0.3V to (IN + 0.3V)  
 AGND to PGND.....-0.3V to +0.3V  
 OUT Short Circuit to GND..... 10s  
 Continuous Power Dissipation ( $T_A = +70^\circ\text{C}$ )  
     6-Pin SOT23-6 (derate 8.7mW/ $^\circ\text{C}$  above +70 $^\circ\text{C}$ ) .....695mW  
     6-Pin TDFN (derate 18.2mW/ $^\circ\text{C}$  above +70 $^\circ\text{C}$ ) .....1454.5mW

Operating Temperature Range..... -40 $^\circ\text{C}$  to +85 $^\circ\text{C}$   
 Junction Temperature..... +150 $^\circ\text{C}$   
 Storage Temperature..... -65 $^\circ\text{C}$  to +150 $^\circ\text{C}$   
 Lead Temperature (soldering, 10s) ..... +300 $^\circ\text{C}$

*Stresses beyond those listed under "Absolute Maximum Ratings" may cause permanent damage to the device. These are stress ratings only, and functional operation of the device at these or any other conditions beyond those indicated in the operational sections of the specifications is not implied. Exposure to absolute maximum rating conditions for extended periods may affect device reliability.*

**Electrical Characteristics**

( $V_{IN} = 3.6\text{V}$ ,  $\overline{\text{SHDN}} = \text{IN}$ ,  $T_A = 0^\circ\text{C}$  to +85 $^\circ\text{C}$ . Typical parameters are at  $T_A = +25^\circ\text{C}$ , unless otherwise noted.) (Note 1)

PARAMETER	SYMBOL	CONDITIONS	MIN	TYP	MAX	UNITS
Input Voltage Range	$V_{IN}$	$I(\text{LX}) < 400\text{mA}$	2.5		5.5	V
		$I(\text{LX}) < 200\text{mA}$ (MAX1921EUT15, MAX1921EUT18)	2.0		2.5	
Startup Voltage					2.0	V
UVLO Threshold	UVLO	$V_{IN}$ rising		1.85	1.95	V
		$V_{IN}$ falling	1.50	1.65		
UVLO Hysteresis				200		mV
Quiescent Supply Current	$I_{IN}$	No switching, no load		50	70	$\mu\text{A}$
Quiescent Supply Current Dropout	$I_{IN}$	$\overline{\text{SHDN}} = \text{IN}$ , OUT/FB = 0		220	300	$\mu\text{A}$
Shutdown Supply Current	$I_{\overline{\text{SHDN}}}$	$\overline{\text{SHDN}} = \text{GND}$		0.1	4.0	$\mu\text{A}$
Output Voltage Accuracy (MAX1921)		$I_{OUT} = 0$ , $T_A = +25^\circ\text{C}$	-1.5		+1.5	%
		$I_{OUT} = 0$ to 400mA, $T_A = -40^\circ\text{C}$ to +85 $^\circ\text{C}$	-3		+3	
		$I_{OUT} = 0$ to 200mA, $T_A = -40^\circ\text{C}$ to +85 $^\circ\text{C}$	-3		+3	
OUT BIAS Current	$I_{OUT}$	$\overline{\text{SHDN}} = 0$			1	$\mu\text{A}$
		OUT at regulation voltage		8	16	
Output Voltage Range (MAX1920)		Figure 4, $I_N = 4.5\text{V}$	1.25		4.00	V
FB Feedback Threshold (MAX1920)	$V_{FB}$	$T_A = +25^\circ\text{C}$	1.231	1.25	1.269	V
			1.220	1.25	1.280	
		$T_A = -40^\circ\text{C}$ to +85 $^\circ\text{C}$	1.210		1.280	
FB Feedback Hysteresis (MAX1920)	$V_{HYS}$			5		mV
FB Bias Current (MAX1920)	$I_{FB}$	FB = 1.5V		0.01	0.20	$\mu\text{A}$
Load Regulation		$I_{OUT} = 0$ to 400mA		0.005		%/mA
Line Regulation		$V_{IN} = 2.5\text{V}$ to 5.5V		0.2		%/V
$\overline{\text{SHDN}}$ Input Voltage High	$V_{IH}$		1.6			V
$\overline{\text{SHDN}}$ Input Voltage Low	$V_{IL}$				0.4	V
$\overline{\text{SHDN}}$ Leakage Current	$I_{\overline{\text{SHDN}}}$	$\overline{\text{SHDN}} = \text{GND}$ or IN		0.001	1.000	$\mu\text{A}$
High-Side Current Limit	$I_{LIMP}$		525	730	950	mA

Electrical Characteristics (continued)

( $V_{IN} = 3.6V$ ,  $\overline{SHDN} = IN$ ,  $T_A = 0^\circ C$  to  $+85^\circ C$ . Typical parameters are at  $T_A = +25^\circ C$ , unless otherwise noted.) (Note 1)

PARAMETER	SYMBOL	CONDITIONS	MIN	TYP	MAX	UNITS
Low-Side Current Limit	$I_{LIMN}$		350	550	800	mA
High-Side On-Resistance	$R_{ONHS}$	$I_{LX} = -40mA$ , $V_{IN} = 3V$		0.6	1.1	$\Omega$
Rectifier On-Resistance	$R_{ONSR}$	$I_{LX} = 40mA$ , $V_{IN} = 3V$		0.5	0.9	$\Omega$
Rectifier Off-Current Threshold	$I_{LXOFF}$			60		mA
LX Leakage Current	$I_{LXLEAK}$	$IN = \overline{SHDN} = 5.5V$ , $LX = 0$ to $IN$		0.1	5.0	$\mu A$
LX Reverse Leakage Current	$I_{LXLKR}$	$IN$ unconnected, $V_{LX} = 5.5V$ , $\overline{SHDN} = GND$		0.1	5.0	$\mu A$
Minimum On-Time	$t_{ON(MIN)}$		0.28	0.4	0.5	$\mu s$
Minimum Off-Time	$t_{OFF(MIN)}$		0.28	0.4	0.5	$\mu s$

Note 1: All devices are 100% production tested at  $T_A = +25^\circ C$ . Limits over the operating temperature range are guaranteed by design.

Typical Operating Characteristics

( $C_{IN} = 2.2\mu F$  ceramic, Circuit of Figure 1, components of Table 1, unless otherwise noted.)

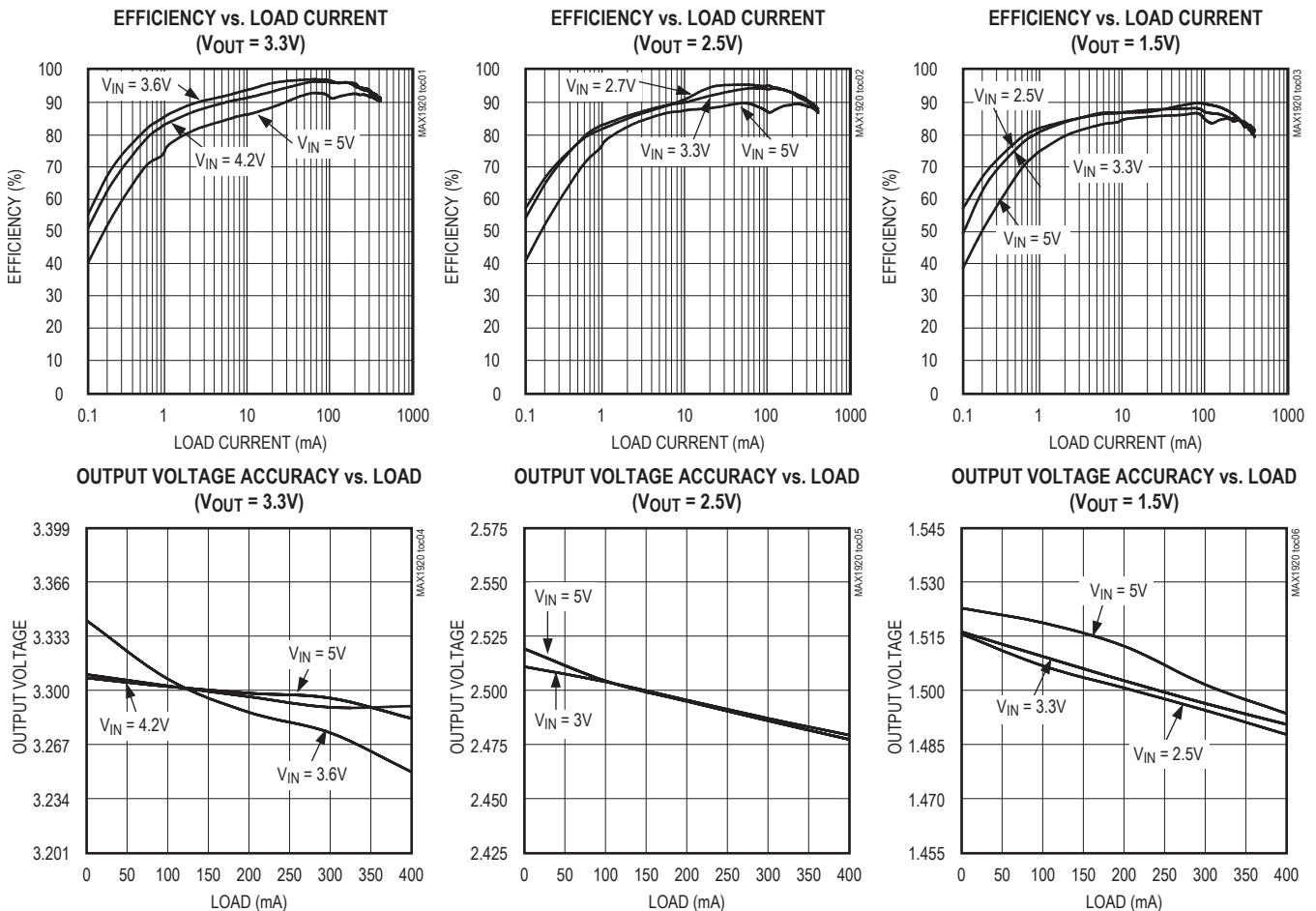

Typical Operating Characteristics (continued)

( $C_{IN} = 2.2\mu\text{F}$  ceramic, Circuit of Figure 1, components of Table 1, unless otherwise noted.)

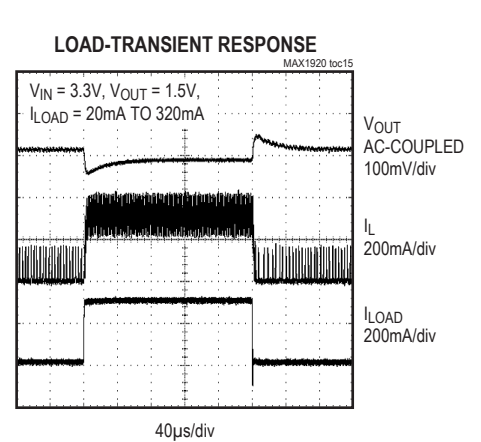
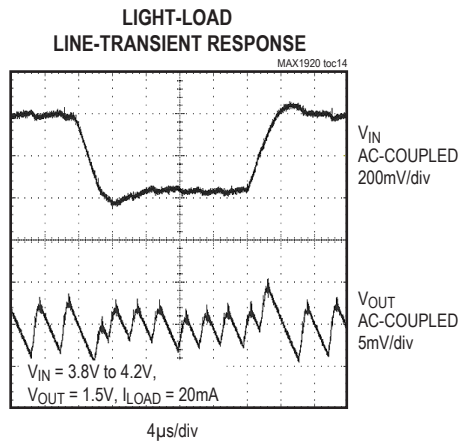
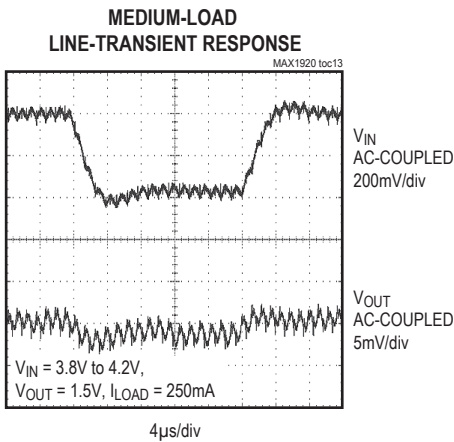
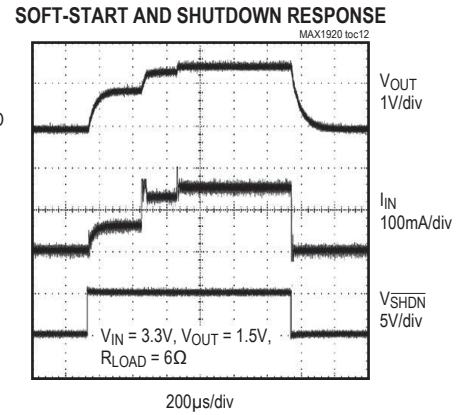
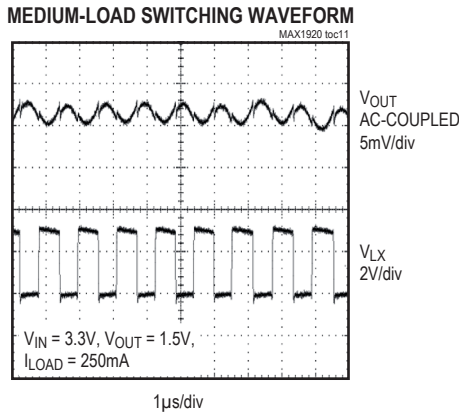
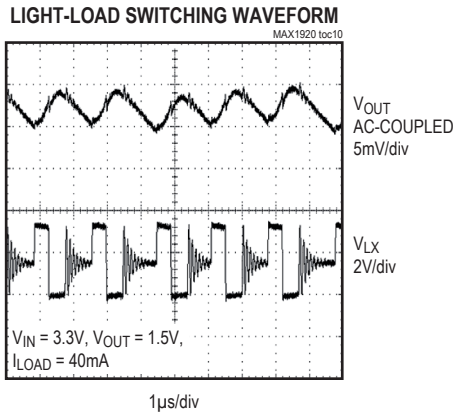
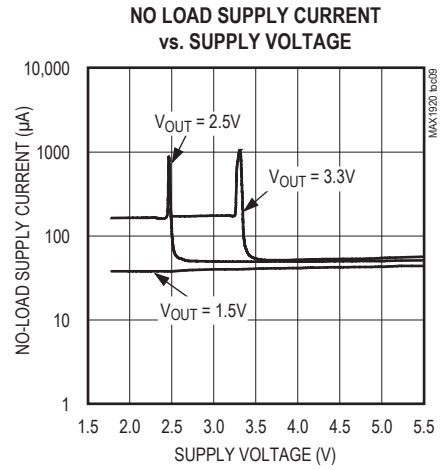
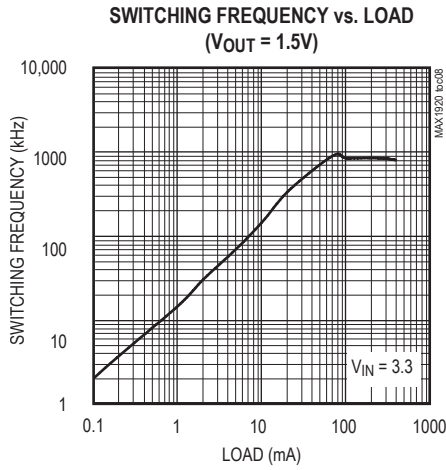
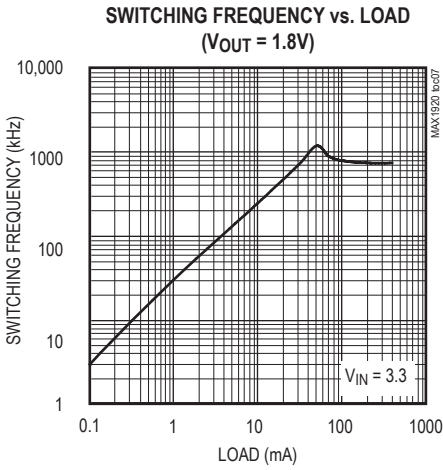

Pin Description

PIN		NAME	FUNCTION
SOT	TDFN*		
1	2	IN	Supply voltage input for MAX1921EUT15 and MAX1921EUT18 is 2V to 5.5V. Supply voltage input for MAX1920 and other voltage versions of MAX1921 is 2.5V to 5.5V. Bypass IN to GND with a 2.2µF ceramic capacitor as close as possible to IN.
2	6	AGND	Analog Ground. Connect to PGND.
3	1	$\overline{\text{SHDN}}$	Active-Low Shutdown Input. Connect $\overline{\text{SHDN}}$ to IN for normal operation. In shutdown, LX becomes high-impedance and quiescent current drops to 0.1µA.
4	—	OUT	MAX1921 Voltage Sense Input. OUT is connected to an internal voltage-divider.
4	5	FB	MAX1920 Voltage Feedback Input. FB regulates to 1.25V nominal. Connect FB to an external resistive voltage-divider between the output voltage and GND.
5	3	PGND	Power Ground. Connect to AGND.
6	4	LX	Inductor Connection

\*MAX1920 only.

Detailed Description

The MAX1920/MAX1921 step-down DC-DC converters deliver over 400mA to outputs as low as 1.25V. They use a unique proprietary current-limited control scheme that maintains extremely low quiescent supply current (50µA), and their high 1.2MHz (max) operating frequency permits small, low-cost external components.

Control Scheme

The MAX1920/MAX1921 use a proprietary, current-limited control scheme to ensure high-efficiency, fast transient response, and physically small external components. This control scheme is simple: when the output voltage is out of regulation, the error comparator begins a switching cycle by turning on the high-side switch. This switch remains on until the minimum on-time of 400ns expires and the output voltage regulates or the current-limit threshold is exceeded. Once off, the high-side switch remains off until the minimum off-time of 400ns expires and the output voltage falls out of regulation. During this period, the low-side synchronous rectifier turns on and remains on until

either the high-side switch turns on again or the inductor current approaches zero. The internal synchronous rectifier eliminates the need for an external Schottky diode.

This control scheme allows the MAX1920/MAX1921 to provide excellent performance throughout the entire load-current range. When delivering light loads, the high-side switch turns off after the minimum on-time to reduce peak inductor current, resulting in increased efficiency and reduced output voltage ripple. When delivering medium and higher output currents, the MAX1920/MAX1921 extend either the on-time or the off-time, as necessary to maintain regulation, resulting in nearly constant frequency operation with high-efficiency and low-output voltage ripple.

Shutdown Mode

Connecting  $\overline{\text{SHDN}}$  to GND places the MAX1920/MAX1921 in shutdown mode and reduces supply current to 0.1µA. In shutdown, the control circuitry, internal switching MOSFET, and synchronous rectifier turn off and LX becomes high impedance. Connect SHDN to IN for normal operation.

Soft-Start

The MAX1920/MAX1921 have internal soft-start circuitry that limits current draw at startup, reducing transients on the input source. Soft-start is particularly useful for higher impedance input sources, such as Li+ and alkaline cells. Soft-start is implemented by starting with the current limit at 25% of its full current value and gradually increasing it in 25% steps until the full current limit is reached. See Soft-Start and Shutdown Response in the *Typical Operating Characteristics*.

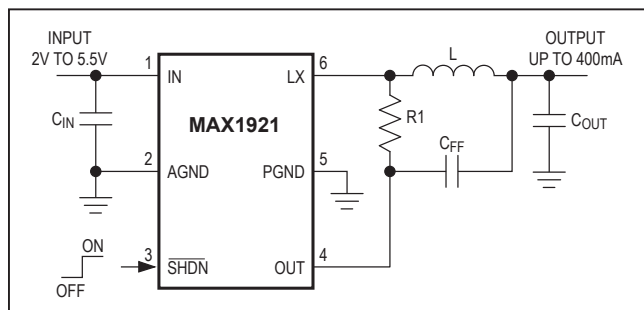

Figure 1. Typical Output Application Circuit (MAX1921)

**Design Procedure**

The MAX1920/MAX1921 are optimized for small external components and fast transient response. There are several application circuits (Figures 1 through 4) to allow the choice between ceramic or tantalum output capacitor and internally or externally set output voltages. The use of a small ceramic output capacitor is preferred for higher reliability, improved voltage-positioning transient response, reduced output ripple, and the smaller size and greater availability of ceramic versus tantalum capacitors.

**Voltage Positioning**

Figures 1 and 2 are the application circuits that utilize small ceramic output capacitors. For stability, the circuit obtains feedback from the LX node through R1, while load transients are fed-forward through CFF. Because there is no D.C. feedback from the output, the output voltage exhibits load regulation that is equal to the output load current multiplied by the inductor’s series resistance. This small amount of load regulation is similar to voltage positioning as used by high-powered microprocessor supplies intended for personal computers. For the MAX1920/MAX1921, voltage positioning eliminates or greatly reduces undershoot and overshoot during load transients (see the *Typical Operating Characteristics*), which effectively halves the peak-to-peak output voltage excursions compared to traditional step-down converters.

**Table 1. MAX1921 Suggested Components for Figure 1**

OUTPUT	INPUT SOURCE		
	5V	3.3V, 1 Li+, 3 x AA	2.5V, 2 x AA
3.3V 3.0V	L = 10µH, C <sub>OUT</sub> = 10µF, R1 = 8.25kΩ, C <sub>FF</sub> = 3300pF		N/A
2.5V	L = 6.8µH, C <sub>OUT</sub> = 6.8µF, R1 = 5.62kΩ, C <sub>FF</sub> = 4700pF		
1.8V 1.5V	L = 10µH, C <sub>OUT</sub> = 10µF, R1 = 8.25kΩ, C <sub>FF</sub> = 3300pF	L = 4.7µH, C <sub>OUT</sub> = 4.7µF, R1 = 4.75kΩ, C <sub>FF</sub> = 5600pF	

For convenience, Table 1 lists the recommended external component values for use with the MAX1921 application circuit of Figure 1 with various input and output voltages.

**Induction Selection**

In order to calculate the smallest inductor, several calculations are needed. First, calculate the maximum duty cycle of the application as:

$$\text{DutyCycle (MAX)} = \frac{V_{\text{OUT}}}{V_{\text{IN (MIN)}}} \times 100\%$$

Second, calculate the critical voltage across the inductor as:

$$\begin{aligned} &\text{if DutyCycle(MAX)} < 50\%, \\ &\text{then } V_{\text{CRITICAL}} = (V_{\text{IN(MIN)}} - V_{\text{OUT}}), \\ &\text{else } V_{\text{CRITICAL}} = V_{\text{OUT}} \end{aligned}$$

Last, calculate the minimum inductor value as:

$$L(\text{MIN}) = 2.5 \times 10^{-6} \times V_{\text{CRITICAL}}$$

Select the next standard value larger than L(MIN). The L(MIN) calculation already includes a margin for inductance tolerance. Although values much larger than L(MIN) work, transient performance, efficiency, and inductor size suffer.

A 550mA rated inductor is enough to prevent saturation for output currents up to 400mA. Saturation occurs when the inductor’s magnetic flux density reaches the maximum level the core can support and inductance falls. Choose a low DC-resistance inductor to improve efficiency. Tables 2 and 3 list some suggested inductors and suppliers.

**Table 2. Suggested Inductors**

PART NUMBER	L (µH)	R <sub>L</sub> (ohms max)	Isat (A)	SIZE
Coilcraft LPO1704	4.7	0.200	1.10	6.6 x 5.5 x 1.0 = 36.3mm <sup>3</sup>
	6.8	0.320	0.90	
	10	0.410	0.80	
Sumida CDRH3D16	4.7	0.080	0.90	3.8 x 3.8 x 1.8 = 26.0mm <sup>3</sup>
	6.8	0.095	0.73	
	10	0.160	0.55	
Sumida CDRH2D18	4.7	0.081	0.63	3.2 x 3.2 x 2.0 = 20.5mm <sup>3</sup>
	6.8	0.108	0.57	
Toko D312F	4.7	0.38	0.74	3.6 x 3.6 x 1.2 = 15.6mm <sup>3</sup>
	10	0.79	0.50	
Toko D412F	4.7	0.230	0.84	4.6 x 4.6 x 1.2 = 25.4mm <sup>3</sup>
	10	0.490	0.55	
Toko D52LC	4.7	0.087	1.14	5.0 x 5.0 x 2.0 = 50.0mm <sup>3</sup>
	6.8	0.105	0.95	
	10	0.150	0.76	

**Capacitor Selection**

For nearly all applications, the input capacitor,  $C_{IN}$ , may be as small as 2.2 $\mu$ F ceramic with X5R or X7R dielectric. The input capacitor filters peak currents and noise at the voltage source and, therefore, must meet the input ripple requirements and voltage rating. Calculate the maximum RMS input current as:

$$I_{IN} (RMS) = I_{OUT} (MAX) \times \frac{\sqrt{V_{OUT} (V_{IN} - V_{OUT})}}{V_{IN}}$$

The output capacitor,  $C_{OUT}$ , may be either ceramic or tantalum depending upon the chosen application circuit (see Figures 1 through 4). Table 3 lists some suggested capacitor suppliers.

**Ceramic Output Capacitor**

For ceramic  $C_{OUT}$ , use the application circuit of Figure 1 or Figure 2. Calculate the minimum capacitor value as:

$$C_{OUT(MIN)} = 2.5 \times 10^{-6} \times V_{CRITICAL}$$

Select the next standard value larger than  $C_{OUT(MIN)}$ . The  $C_{OUT(MIN)}$  calculation already includes a margin for capacitor tolerance. Values much larger than  $C_{OUT(MIN)}$  always improve transient performance and stability, but capacitor size and cost increase.

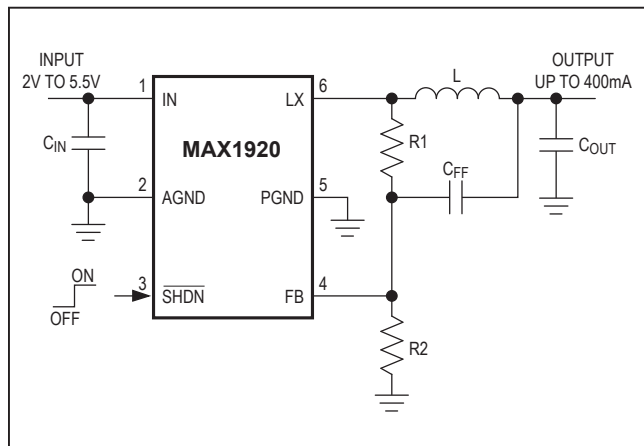

Figure 2. Typical Application Circuit (MAX1920)

**Tantalum Output Capacitor**

For tantalum  $C_{OUT}$ , use the application circuit of Figure 3 or Figure 4. With tantalum  $C_{OUT}$ , the equivalent series resistance (ESR) of  $C_{OUT}$  must be large enough for stability. Generally, 25mV of ESR-ripple at the feedback node is sufficient. The simplified calculation is:

$$ESR_{C_{OUT(MIN)}} = 8.0 \times 10^{-2} \times V_{OUT}$$

Because tantalum capacitors rarely specify minimum ESR, choose a capacitor with typical ESR that is about twice as much as  $ESR_{C_{OUT(MIN)}}$ . Although ESRs greater than this work, output ripple becomes larger.

For tantalum  $C_{OUT}$ , calculate the minimum output capacitance as:

$$C_{OUT} (MIN) = 1.25 \times \frac{L \times I_{OUT} (MAX)}{ESR_{C_{OUT}} (MIN) \times V_{CRITICAL}}$$

The 1.25 multiplier is for capacitor tolerance. Select any standard value larger than  $C_{OUT(MIN)}$ .

**Feedback and Compensation**

The MAX1921 has factory preset output voltages of 1.5V, 1.8V, 2.5V, 3V, and 3.3V, while the MAX1920 is externally adjusted by connecting FB to a resistive voltage-divider. When using a ceramic output capacitor, the feedback network must include a compensation feed-forward capacitor,  $C_{FF}$ .

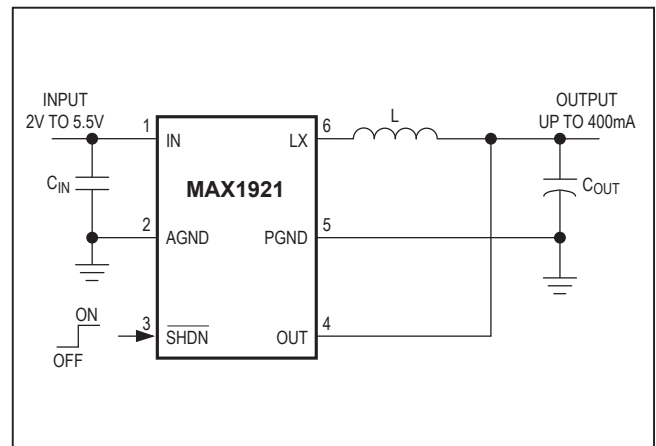

Figure 3. MAX1921 Application Circuit Using Tantalum Output Capacitor



**Table 3. Component Suppliers**

SUPPLIER		PHONE	WEBSITE
Coilcraft		847-639-6400	www.coilcraft.com
Kemet		408-986-0424	www.kemet.com
Murata		814-237-1431	www.murata.com
Sumida	USA	847-956-0666	www.sumida.com
	Japan	81-3-3607-5111	
Taiyo Yuden	USA	408-573-4150	www.T-Yuden.com
	Japan	81-3-3833-5441	www.yuden.co.jp
Toko	USA	847-297-0070	www.tokoam.com
	Japan	81-3-3727-1161	www.toko.co.jp

**MAX1921 Using Ceramic C<sub>OUT</sub>**

When using the application circuit of Figure 1, the inductor’s series resistance causes a small amount of load regulation, as desired for a voltage-positioning load transient response. Choose R1 such that V<sub>OUT</sub> is high at no load by about half of this load regulation. The simplified calculation is:

$$R1 = 5 \times 10^4 \times R_L(\text{MAX})$$

where R<sub>L</sub>(MAX) is the maximum series resistance of the inductor. Select a standard resistor value that is within 20% of this calculation.

Next, calculate C<sub>FF</sub> for 25mV ripple at the internal feedback node. The simplified calculation is:

$$C_{FF} = 2.5 \times 10^{-5} / R1$$

where R1 is the standard resistor value that is used. Select a standard capacitor value that is within 20% of the calculated C<sub>FF</sub>.

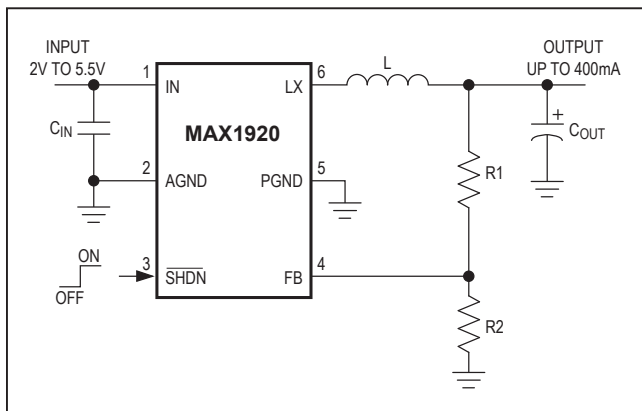

Figure 4. MAX1920 Application Circuit Using Tantalum Output Capacitor

**MAX1920 Using Ceramic C<sub>OUT</sub>**

When using the application circuit of Figure 2, the inductor’s series resistance causes a small amount of load regulation, as desired for a voltage-positioning load transient response. Choose R1 and R2 such that V<sub>OUT</sub> is high at no load by about half of this load regulation:

$$R1 = R2 \times \left( \frac{V_{OUT} + R_L \times I_{OUT}(\text{MAX}) / 2}{V_{REF}} - 1 \right)$$

where R2 is chosen in the 50kΩ to 500kΩ range, V<sub>REF</sub> = 1.25V and R<sub>L</sub> is the typical series resistance of the inductor. Use 1% or better resistors.

Next, calculate the equivalent resistance at the FB node as:

$$R_{eq} = R1 || R2 = \frac{R1 \times R2}{R1 + R2}$$

Then, calculate C<sub>FF</sub> for 25mV ripple at FB. The simplified calculation is:

$$C_{FF} = 2.5 \times 10^{-5} / R_{eq}$$

Select a standard capacitor value that is within 20% of the calculated C<sub>FF</sub>.

**MAX1920 Using Tantalum C<sub>OUT</sub>**

When using the application circuit of Figure 4, choose R1 and R2 such as to obtain the desired V<sub>OUT</sub>:

$$R1 = R2 \times \left( \frac{V_{OUT}}{V_{REF}} - 1 \right)$$

where R2 is chosen to be less than 50kΩ and V<sub>REF</sub> = 1.25V. Use 1% or better resistors.

**Layout Considerations**

High switching frequencies make PC board layout a very important part of design. Good design minimizes excessive EMI on the feedback paths and voltage gradients in the ground plane, both of which can result in instability or regulation errors. Connect the inductor, input filter capacitor, and output filter capacitor as close to the device as possible, and keep their traces short, direct, and wide. Connect their ground pins at a single common node in a star ground configuration. The external voltage-feedback network should be very close to the FB pin, within 0.2in (5mm). Keep noisy traces, such as the LX trace, away from the voltage-feedback network; also keep them separate, using grounded copper. The MAX1920/MAX1921 evaluation kit data sheet includes a proper PC board layout and routing scheme.

Selector Guide

PART	V <sub>OUT</sub> (V)	TOP MARK
MAX1920EUT	Adjustable	ABCO
MAX1920ETT	Adjustable	ADR
MAX1921EUT33	3.3	ABCJ
MAX1921EUT30	3.0	ABCK
MAX1921EUT25	2.5	ABCL
MAX1921EUT18	1.8	ABCM
MAX1921EUT15	1.5	ABCN

Chip Information

TRANSISTOR COUNT: 1467

Package Information

For the latest package outline information and land patterns (footprints), go to [www.maximintegrated.com/packages](http://www.maximintegrated.com/packages). Note that a "+", "#", or "-" in the package code indicates RoHS status only. Package drawings may show a different suffix character, but the drawing pertains to the package regardless of RoHS status.

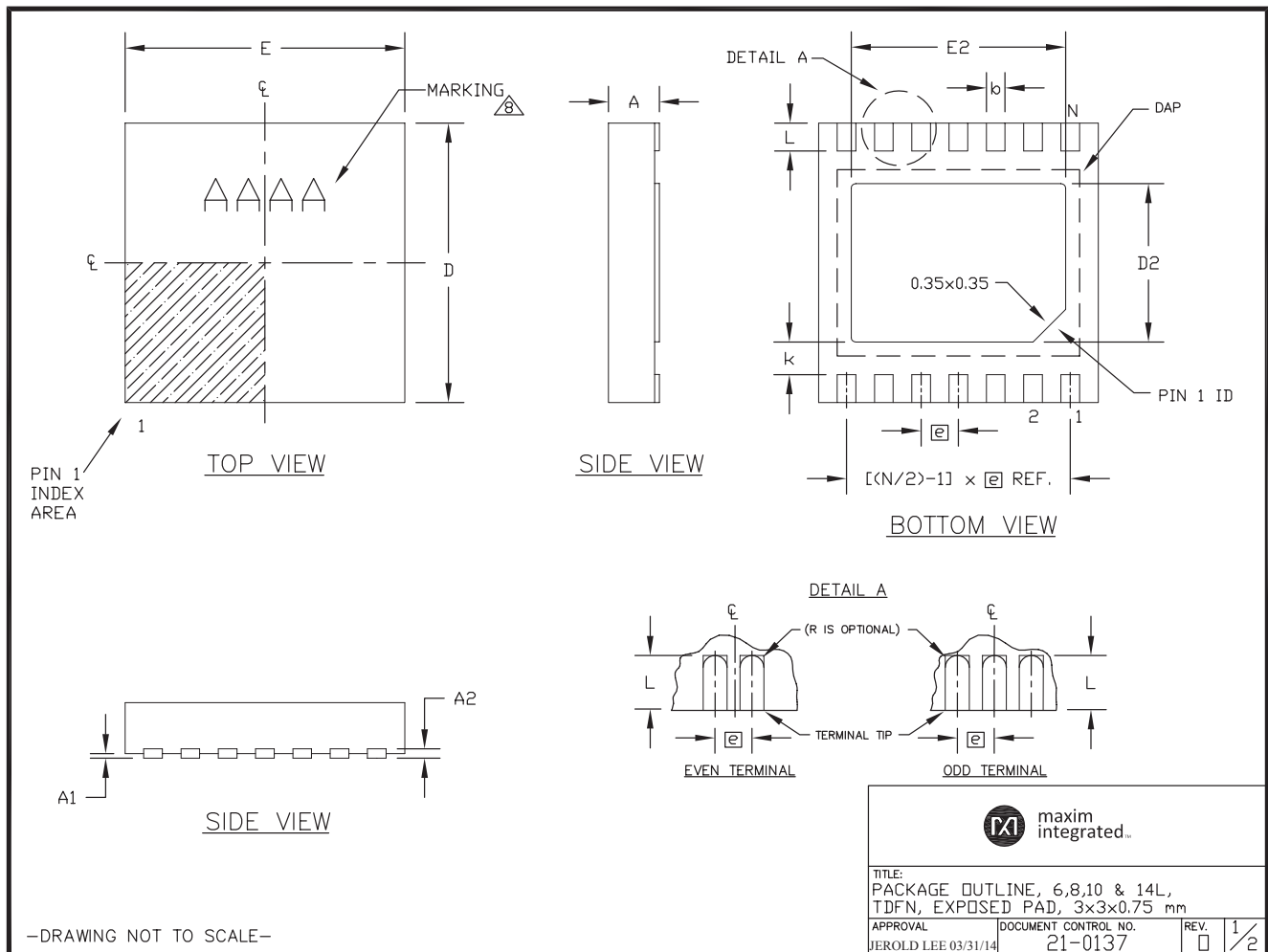

Package Information (continued)

For the latest package outline information and land patterns (footprints), go to [www.maximintegrated.com/packages](http://www.maximintegrated.com/packages). Note that a "+", "#", or "-" in the package code indicates RoHS status only. Package drawings may show a different suffix character, but the drawing pertains to the package regardless of RoHS status.

COMMON DIMENSIONS			
SYMBOL	MIN.	NOM.	MAX.
A	0.70	0.75	0.80
D	2.90	3.00	3.10
E	2.90	3.00	3.10
A1	0.00	0.025	0.05
L	0.20	0.30	0.40
k	0.25 MIN.		
A2	0.20 REF.		

PACKAGE VARIATIONS								
PKG. CODE	N	D2	E2	e	JEDEC SPEC	b	[(N/2)-1] x e	
T633-2	6	1.50±0.10	2.30±0.10	0.95 BSC	MO229 / WEEA	0.40±0.05	1.90 REF	
T633-2C	6	1.50±0.10	2.30±0.10	0.95 BSC	MO229 / WEEA	0.40±0.05	1.90 REF	
T633MK-1	6	1.50±0.10	2.30±0.10	0.95 BSC	MO229 / WEEA	0.40±0.05	1.90 REF	
T833-2	8	1.50±0.10	2.30±0.10	0.65 BSC	MO229 / WEEC	0.30±0.05	1.95 REF	
T833-2C	8	1.50±0.10	2.30±0.10	0.65 BSC	MO229 / WEEC	0.30±0.05	1.95 REF	
T833-3	8	1.50±0.10	2.30±0.10	0.65 BSC	MO229 / WEEC	0.30±0.05	1.95 REF	
T1033-1	10	1.50±0.10	2.30±0.10	0.50 BSC	MO229 / WEED-3	0.25±0.05	2.00 REF	
T1033-1C	10	1.50±0.10	2.30±0.10	0.50 BSC	MO229 / WEED-3	0.25±0.05	2.00 REF	
T1033MK-1	10	1.50±0.10	2.30±0.10	0.50 BSC	MO229 / WEED-3	0.25±0.05	2.00 REF	
T1033-2	10	1.50±0.10	2.30±0.10	0.50 BSC	MO229 / WEED-3	0.25±0.05	2.00 REF	
T1433-1	14	1.70±0.10	2.30±0.10	0.40 BSC	----	0.20±0.05	2.40 REF	
T1433-2	14	1.70±0.10	2.30±0.10	0.40 BSC	----	0.20±0.05	2.40 REF	
T1433-2C	14	1.70±0.10	2.30±0.10	0.40 BSC	----	0.20±0.05	2.40 REF	
T1433-3F	14	1.70±0.10	2.30±0.10	0.40 BSC	----	0.20±0.05	2.40 REF	

NOTES:

- ALL DIMENSIONS ARE IN mm. ANGLES IN DEGREES.
- COPLANARITY SHALL NOT EXCEED 0.08 mm.
- WARPAGE SHALL NOT EXCEED 0.10 mm.
- PACKAGE LENGTH/PACKAGE WIDTH ARE CONSIDERED AS SPECIAL CHARACTERISTIC(S).
- DRAWING CONFORMS TO JEDEC MO229, EXCEPT DIMENSIONS "D2" AND "E2", AND T1433-1 & T1433-2.
- "N" IS THE TOTAL NUMBER OF LEADS.
- NUMBER OF LEADS SHOWN ARE FOR REFERENCE ONLY.
-  MARKING IS FOR PACKAGE ORIENTATION REFERENCE ONLY.
- ALL DIMENSIONS APPLY TO BOTH LEADED (-) AND PbFREE (+) PKG. CODES.



TITLE:  
PACKAGE OUTLINE, 6,8,10 & 14L,  
TDFN, EXPOSED PAD, 3x3x0.75 mm

APPROVAL JEROLD LEE 03/31/14	DOCUMENT CONTROL NO. 21-0137	REV. 0	2/2
---------------------------------	---------------------------------	-----------	-----

-DRAWING NOT TO SCALE-

**Package Information (continued)**

For the latest package outline information and land patterns (footprints), go to [www.maximintegrated.com/packages](http://www.maximintegrated.com/packages). Note that a "+", "#", or "-" in the package code indicates RoHS status only. Package drawings may show a different suffix character, but the drawing pertains to the package regardless of RoHS status.

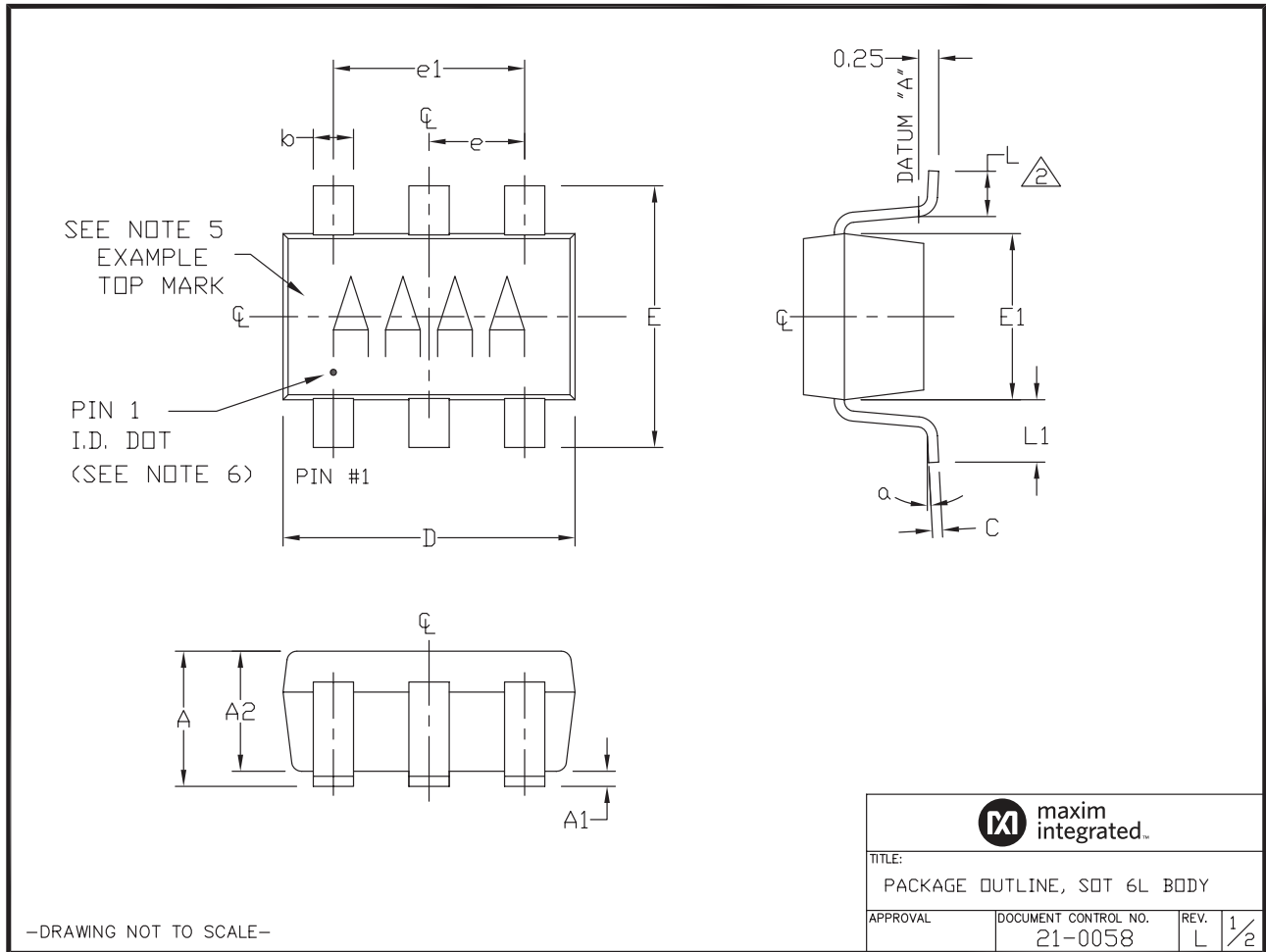



**Package Information (continued)**

For the latest package outline information and land patterns (footprints), go to [www.maximintegrated.com/packages](http://www.maximintegrated.com/packages). Note that a "+", "#", or "-" in the package code indicates RoHS status only. Package drawings may show a different suffix character, but the drawing pertains to the package regardless of RoHS status.

SYMBOL	MIN	NOMINAL	MAX
A	0.90	1.25	1.45
A1	0.00	0.05	0.15
A2	0.90	1.10	1.30
b	0.35	0.40	0.50
C	0.08	0.15	0.20
D	2.80	2.90	3.00
E	2.60	2.80	3.00
E1	1.50	1.625	1.75
L	0.35	0.45	0.60
L1	0.60 REF.		
e1	1.90 BSC.		
e	0.95 BSC.		
α	0°	2.5°	10°

PKG CODES:  
U6-1, U6-2, U6-4, U6CN-2,  
U6SN-1, U6F-6, U6FH-6; U6FH-7

\*\*\* U6FH-7 TO BE USED FOR NP42 PARTS ONLY.

NOTES:

- ALL DIMENSIONS ARE IN MILLIMETERS.
-  FOOT LENGTH MEASURED AT INTERCEPT POINT BETWEEN DATUM A & LEAD SURFACE.
- PACKAGE OUTLINE EXCLUSIVE OF MOLD FLASH & METAL BURR. MOLD FLASH, PROTRUSION OR METAL BURR SHOULD NOT EXCEED 0.25mm.
- PACKAGE OUTLINE INCLUSIVE OF SOLDER PLATING.
- PIN 1 IS LOWER LEFT PIN WHEN READING TOP MARK FROM LEFT TO RIGHT. (SEE EXAMPLE TOP MARK)
- PIN 1 I.D. DOT IS 0.3mm Ø MIN. LOCATED ABOVE PIN 1.
- MEETS JEDEC MO178, VARIATION AB.
- SOLDER THICKNESS MEASURED AT FLAT SECTION OF LEAD BETWEEN 0.08mm AND 0.15mm FROM LEAD TIP.
- LEAD TO BE COPLANAR WITHIN 0.1mm.
- NUMBER OF LEADS SHOWN ARE FOR REFERENCE ONLY.
- MARKING IS FOR PACKAGE ORIENTATION REFERENCE ONLY.
- ALL DIMENSIONS APPLY TO BOTH LEADED (-) AND PbFREE (+) PKG. CODES.

maxim integrated.

TITLE:  
PACKAGE OUTLINE, SOT 6L BODY

APPROVAL	DOCUMENT CONTROL NO. 21-0058	REV. L	2/2
----------	---------------------------------	-----------	-----

-DRAWING NOT TO SCALE-

For pricing, delivery, and ordering information, please contact Maxim Direct at 1-888-629-4642, or visit Maxim Integrated's website at [www.maximintegrated.com](http://www.maximintegrated.com).

Maxim Integrated cannot assume responsibility for use of any circuitry other than circuitry entirely embodied in a Maxim Integrated product. No circuit patent licenses are implied. Maxim Integrated reserves the right to change the circuitry and specifications without notice at any time. The parametric values (min and max limits) shown in the Electrical Characteristics table are guaranteed. Other parametric values quoted in this data sheet are provided for guidance.