



Chipsmall Limited consists of a professional team with an average of over 10 year of expertise in the distribution of electronic components. Based in Hongkong, we have already established firm and mutual-benefit business relationships with customers from,Europe,America and south Asia,supplying obsolete and hard-to-find components to meet their specific needs.

With the principle of “Quality Parts,Customers Priority,Honest Operation,and Considerate Service”,our business mainly focus on the distribution of electronic components. Line cards we deal with include Microchip,ALPS,ROHM,Xilinx,Pulse,ON,Everlight and Freescale. Main products comprise IC,Modules,Potentiometer,IC Socket,Relay,Connector.Our parts cover such applications as commercial,industrial, and automotives areas.

We are looking forward to setting up business relationship with you and hope to provide you with the best service and solution. Let us make a better world for our industry!



Contact us

Tel: +86-755-8981 8866 Fax: +86-755-8427 6832

Email & Skype: info@chipsmall.com Web: www.chipsmall.com

Address: A1208, Overseas Decoration Building, #122 Zhenhua RD., Futian, Shenzhen, China



MAXIM

MAX196 Evaluation Kit

General Description

The MAX196 evaluation kit (EV kit) is an assembled and tested board for prototyping designs using the MAX196 12-bit, multi-range data-acquisition system (DAS). The board includes voltage buffers for all six analog input channels, and is designed to be operated in a stand-alone demo mode using a binary LED readout. It can be adapted to a user-provided 16-bit microprocessor (μ P) bus. The EV kit requires a +5V power supply for the MAX196 and ± 15 V power supplies for the op amps.

The MAX196 EV kit evaluates both the MAX196 and the MAX198. To evaluate the MAX198, order a free sample of the MAX198BCNI along with the MAX196 EV kit.

Maxim also offers a complete μ P-based EV system for the 8-bit interface version of this device, the MAX197. Refer to the MAX197 EV kit manual.

Features

- ◆ Stand-Alone Demo
- ◆ Proven PC Board Layout
- ◆ User Prototype Area
- ◆ Fully Assembled and Tested
- ◆ Jumper-Selectable Configuration

Ordering Information

PART	TEMP. RANGE	BOARD TYPE
MAX196EVKIT-DIP	+25°C	Through-Hole

EV Kit

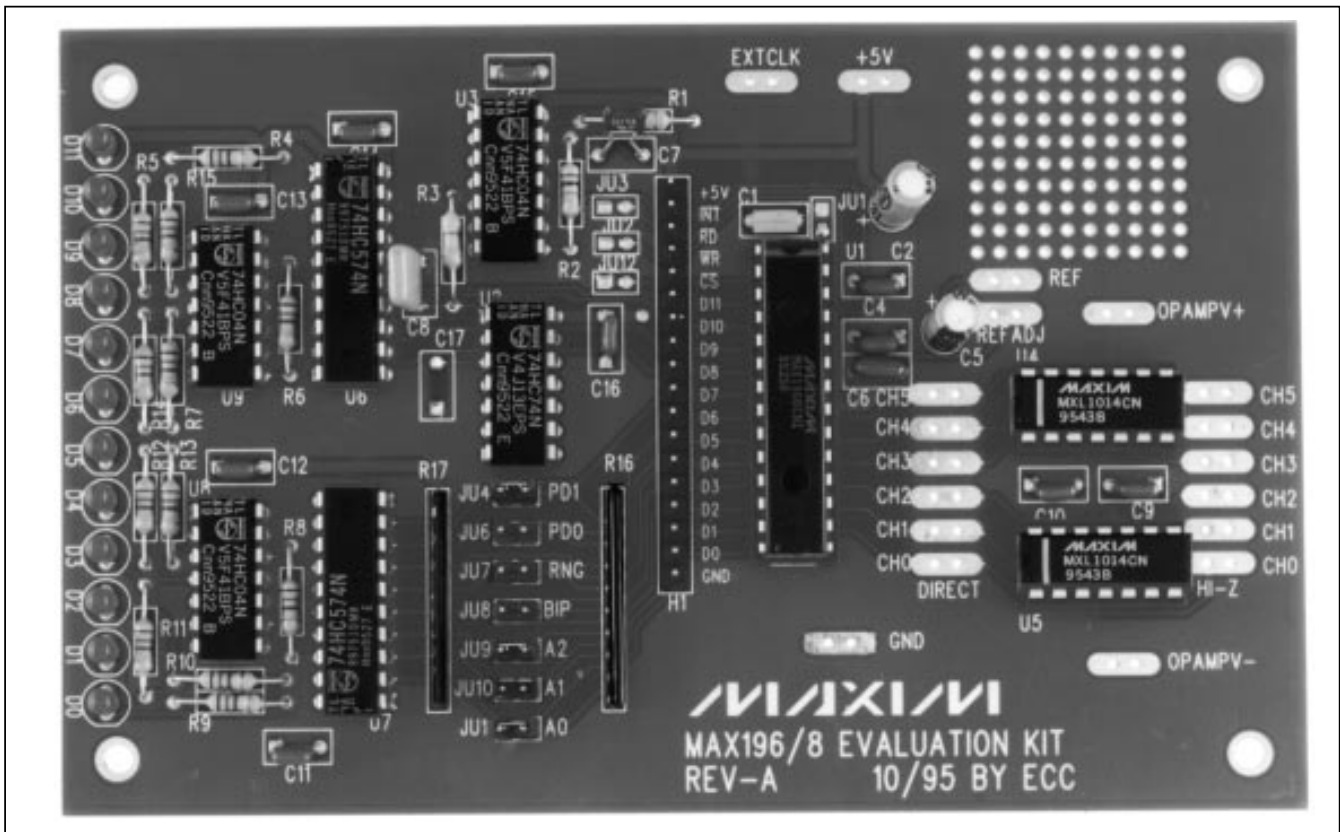

Evaluates: MAX196/MAX198

MAX196 Evaluation Kit

Component List

DESIGNATION	QTY	DESCRIPTION
C1	1	100pF ceramic capacitor
C2, C4, C9–C16	10	0.1μF ceramic capacitors
C3, C5	2	10μF ceramic capacitors
C6	1	0.01μF ceramic capacitor
C7	1	0.22μF ceramic capacitor
C8	1	1μF ceramic capacitor
H1	1	18-pin header
JU1, JU2, JU3, JU12	0	Open
JU4, JU6–JU11	7	2-pin jumpers
D0–D11	12	LEDs
R1, R2	2	10kΩ, 5% resistors
R3	1	470kΩ, 5% resistor
R4–R15	12	620Ω, 5% resistors
R16	1	10kΩ, 9-pin SIP resistor
R17	1	100kΩ, 9-pin SIP resistor
U1	1	Maxim MAX196BCNI
U2	1	74HC74 dual flip-flop
U3, U8, U9	3	74HC04 hex inverter
U4, U5	2	Maxim MXL1014CN quad op amps
U6, U7	2	74HC574 octal latch

Quick Start

The MAX196 EV kit is fully assembled and tested. Follow these steps to verify board operation. **Do not turn on the power supply until all connections are completed.**

- 1) Connect a +5V supply to the pad labeled +5V, and connect the ground return to the pad labeled GND.
- 2) Connect ±15V supplies to the pads labeled, respectively, OPAMPV+ and OPAMPV-. Connect the power supply's common terminal to the EV kit's GND pad.
- 3) Set configuration jumpers as shown in Table 1. This selects channel 0 with a ±10V input range and puts the device in no power-down/internal clock mode.
- 4) Apply an input signal to the "high-Z" channel 0 input pad located at the far-right side of the board.
- 5) Turn on the power supplies.
- 6) Observe binary readout on the twelve LEDs.

Table 1. Default Jumper Settings

JUMPER	SETTING
JU1	Short (default trace)
JU2	Short (default trace)
JU3	Short (default trace)
JU4 (PD1)	Short
JU5 (PD0)	Open
JU7 (RNG)	Open
JU8 (BIP)	Open
JU9 (A2)	Short
JU10 (A1)	Short
JU11 (A0)	Short
JU12	Short (default trace)

Detailed Description

Stand-Alone Demo Circuit Operation

The demo circuit is a state-machine driven by a 1kHz system clock that generates the \overline{WR} , \overline{WR} , and \overline{INT} pulses. The circuit runs continuously, writing the command word programmed by the jumpers, and displaying the results on the LEDs.

At power-up, R3 and C8 reset flip-flop, U2, generating a \overline{WR} pulse. On the rising edge of \overline{WR} , the MAX196 latches the command word selected by JU4–JU11. The rising edge of the system clock sets \overline{WR} high, initiating a conversion. When the MAX196 completes the conversion, the MAX196 drives \overline{INT} low. After \overline{INT} falls, \overline{RD} goes low at the next rising edge of the system clock, placing the data onto the data bus. When \overline{RD} goes low, \overline{INT} goes high, so that the next system clock cycle drives \overline{RD} high. \overline{RD} 's rising edge latches the data into U6 and U7. U8 and U9 drive the LED display. After \overline{RD} returns high, \overline{WR} goes low, and the cycle repeats (Figure 1).

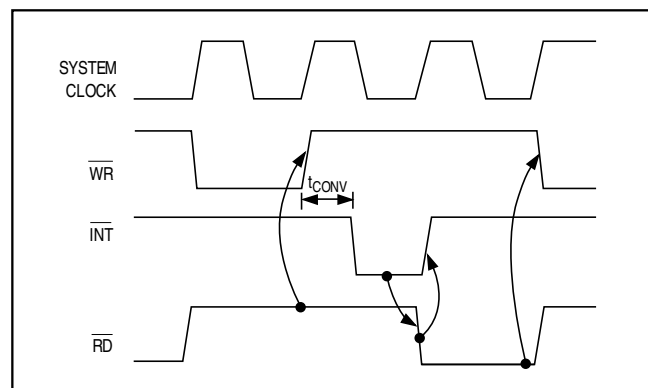

Figure 1. MAX196 Stand-Alone Demo Circuit Timing Diagram

MAX196 Evaluation Kit

Evaluates: MAX196/MAX198

Optional Input Buffers

The op amp buffers are MXL1014 precision quad op amps, connected in voltage-follower configurations. These op amps should normally be powered from $\pm 15V$ ($\pm 22V$ absolute maximum). Applications that use only 0V to 4V signals may power the MXL1014 from $\pm 5V$ with good results.

The MAX196 should be driven from a low output impedance signal source (such as an op amp). To use the on-board op amps, drive the HI-Z CH0–CH5 input pads. When using an off-board low-impedance source, unplug the MXL1014s and drive the DIRECT CH0–CH5 input pads.

Configuring the MAX196

Tables 2, 3, and 4 show the jumper connections for the different operating modes of the MAX196 EV kit. Refer to Table 2 for clock and power-down modes, Table 3 for input range selection, and Table 4 for channel selection.

Table 2. Clock and Power-Down Selection

JU4 (PD1)	JU5 (PD0)	JU1	FUNCTION
Short	Short	Open	No power-down, external clock mode
Short	Open	Short	No power-down, internal clock mode
Open	Short	X	Standby power-down between readings
Open	Open	X	Full power-down between readings

Table 3. Range and Polarity Selection

JU8 (BIP)	JU7 (RNG)	MAX196 INPUT RANGE (V)	MAX198 INPUT RANGE (V)
Short	Short	0 to 5	0 to $V_{REF}/2$
Short	Open	0 to 10	0 to V_{REF}
Open	Short	± 5	$\pm V_{REF}/2$
Open	Open	± 10	$\pm V_{REF}$

Table 4. Channel Selection

JU9 (A2)	JU10 (A1)	JU11 (A0)	CHANNEL
Short	Short	Short	CH0
Short	Short	Open	CH1
Short	Open	Short	CH2
Short	Open	Open	CH3
Open	Short	Short	CH4
Open	Short	Open	CH5

Using an External Clock

As shipped from the factory, the MAX196 EV kit uses C1 as a timing capacitor for internal clock mode. To use an external clock, cut JU1 and apply the external clock source to the EXTCLK input pad. Start up the kit with JU4 (PD1) and JU5 (PD0) shorted.

Evaluating the MAX198

To evaluate the MAX198, remove the MAX196 and replace it with a MAX198BCNI.

Interfacing to a 16-Bit Bus

The MAX196/MAX198 are designed to connect directly to a 16-bit μP bus using standard chip-select (\overline{CS}), read strobe (\overline{RD}), and write strobe (\overline{WR}) signals. JU2, JU3, and JU12 must be cut to disable the stand-alone circuit (Table 5). All interface signals are provided on header H1. For interface details, refer to the MAX196/MAX198 data sheet.

Table 5. Demo Circuit Jumpers

JU2	JU3	JU12	MODE
Short	Short	Short	Stand-alone demo
Open	Open	Open	Connect to a user-provided system

Evaluates: MAX196/MAX198

MAX196 Evaluation Kit

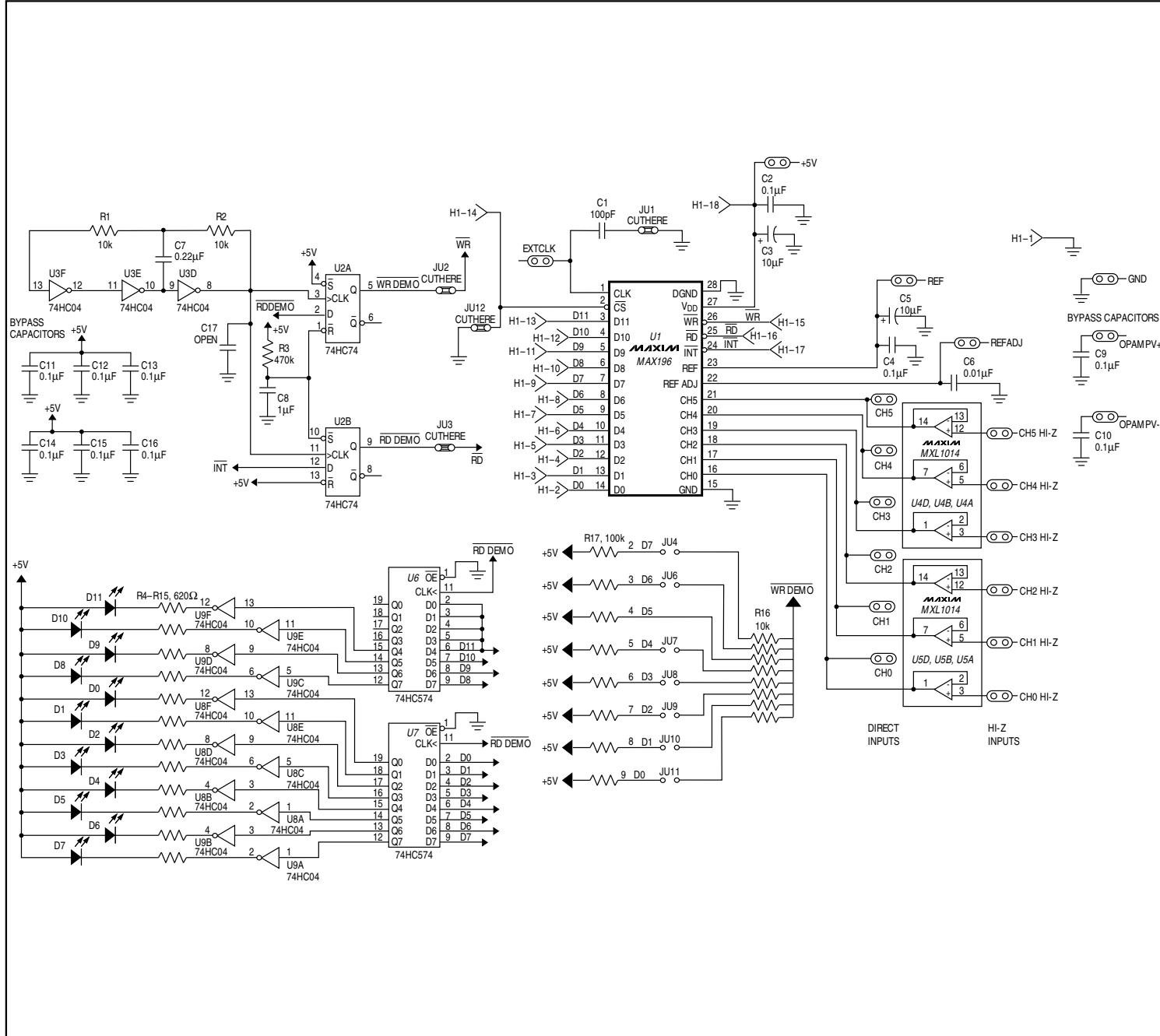

Figure 2. MAX196 EV Kit Schematic

MAX196 Evaluation Kit

Evaluates: MAX196/MAX198

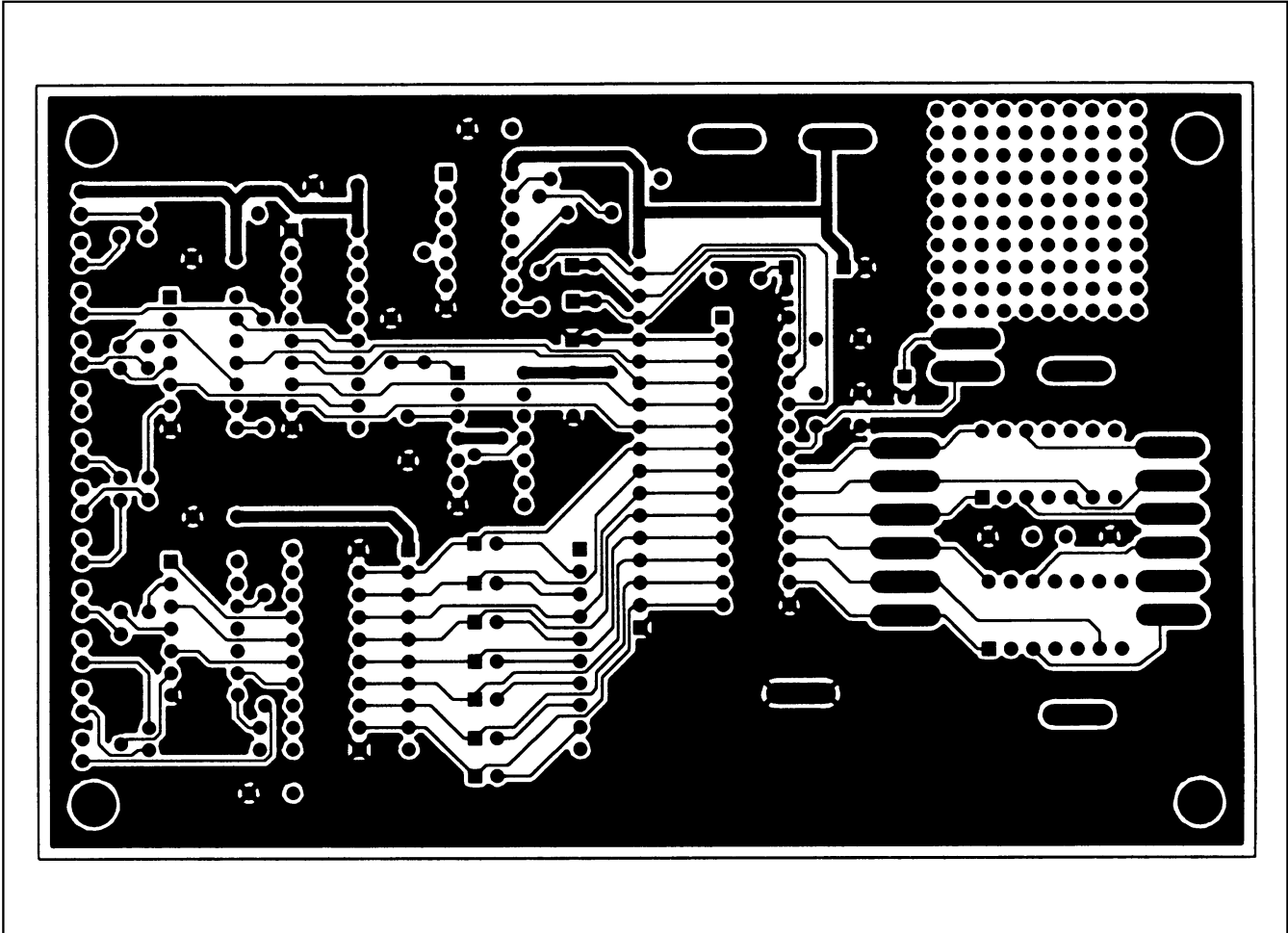

Figure 4. MAX196 EV Kit PC Board Layout—Component Side

MAX196 Evaluation Kit

Evaluates: MAX196/MAX198

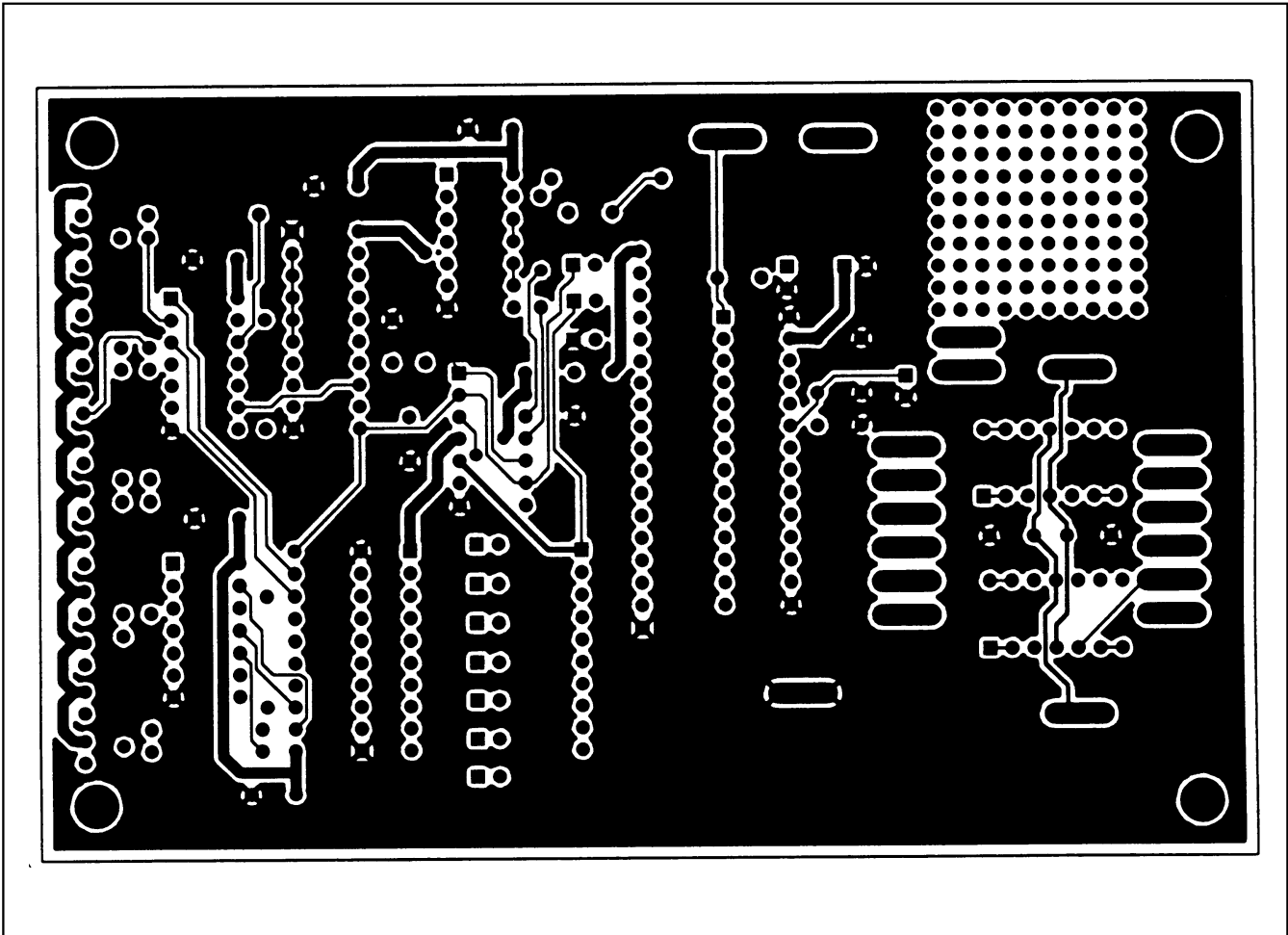

Figure 5. MAX196 EV Kit PC Board Layout—Solder Side

MAX196 Evaluation Kit

Evaluates: MAX196/MAX198

Maxim cannot assume responsibility for use of any circuitry other than circuitry entirely embodied in a Maxim product. No circuit patent licenses are implied. Maxim reserves the right to change the circuitry and specifications without notice at any time.

8 _____ **Maxim Integrated Products, 120 San Gabriel Drive, Sunnyvale, CA 94086 (408) 737-7600**

© 1996 Maxim Integrated Products

Printed USA

MAXIM is a registered trademark of Maxim Integrated Products.