



Chipsmall Limited consists of a professional team with an average of over 10 year of expertise in the distribution of electronic components. Based in Hongkong, we have already established firm and mutual-benefit business relationships with customers from,Europe,America and south Asia,supplying obsolete and hard-to-find components to meet their specific needs.

With the principle of “Quality Parts,Customers Priority,Honest Operation,and Considerate Service”,our business mainly focus on the distribution of electronic components. Line cards we deal with include Microchip,ALPS,ROHM,Xilinx,Pulse,ON,Everlight and Freescale. Main products comprise IC,Modules,Potentiometer,IC Socket,Relay,Connector.Our parts cover such applications as commercial,industrial, and automotives areas.

We are looking forward to setting up business relationship with you and hope to provide you with the best service and solution. Let us make a better world for our industry!



Contact us

Tel: +86-755-8981 8866 Fax: +86-755-8427 6832

Email & Skype: info@chipsmall.com Web: www.chipsmall.com

Address: A1208, Overseas Decoration Building, #122 Zhenhua RD., Futian, Shenzhen, China



General Description

The MAX20090 evaluation kit (EV kit) provides a proven design to evaluate the MAX20090 automotive high-voltage, high-brightness LED (HB LED) controller. The EV kit is set up for boost and buck-boost configurations and operates from a 6V to 18V DC supply voltage. The EV kit is configured to deliver up to 1A to one string of LEDs. The total voltage of the string can vary from 3V to 36V. The anode of the LED string should be connected to the LED+ terminal. The cathode of the LED string can be connected either to PGND (boost mode) or IN (buck-boost mode). In the case of boost mode, the input voltage should not exceed the LED string voltage.

Features

- Configured for a Boost and Buck-Boost Mode
- Analog Dimming Control
- Proven PCB Layout
- Fully Assembled and Tested

Quick Start

Required Equipment

- MAX20090 EV kit
- 12V, 5A DC power supply
- A series-connected LED string rated at 1A
- Oscilloscope with a current probe

Procedure

The EV kit is fully assembled and tested. Follow the steps below to verify board operation. **Caution: Do not turn on power supply until all connections are made.**

- 1) Verify that all jumpers (J1–J4) are in their default positions, as shown in [Table 1](#).
- 2) Connect the positive terminal of the 12V supply to the IN PCB pad and the negative terminal to the nearest GND1 PCB pad.
- 3) Connect the LED string across the LED+ and LED- PCB pads on the EV kit for buck-boost configuration. For boost configuration, connect the LED string across the LED+ and GND2 PCB pads on the EV kit. The LED string voltage should be higher than the input voltage in this configuration.
- 4) Clip the current probe on the wire connected to the LED string.
- 5) Turn on the DC power supply.
- 6) Verify that the LEDs turn on.
- 7) Verify that the oscilloscope displays approximately 1A.

Detailed Description

The MAX20090 EV kit provides a proven design to evaluate the MAX20090 high-voltage HB LED driver with integrated high-side current sense. The EV kit is set up for boost and buck-boost configurations and operates from a 6V to 18V DC supply voltage. The EV kit is configured to deliver up to 1A to a series LED string. The string-forward voltage can vary from 3V to 36V.

[Ordering Information](#) appears at end of data sheet.

Table 1. MAX20090 EV Kit Jumper Descriptions (J1–J4)

JUMPER	SHUNT POSITION	DESCRIPTION
J1	1-2*	Connects the PWMDIM pin of the device to VCC through a 4.99kΩ resistor. The LEDs turn on when the input voltage goes above the UVLO level if J4 is open.
	2-3	Connects the PWMDIM pin to ground through a 4.99kΩ resistor. Need to apply an external PWM signal or a DC voltage on the PWMDIM PCB pad to turn on the LEDs when the input voltage on IN is in the operating range.
	Open	Connects the PWMDIM pin to ground if J4 is installed; otherwise, PWMDIM pin is unconnected.
J2	1-2	Connects VCC to the ICTRL pin. LED current is at the maximum value of 1.1A in this configuration.
	2-3*	ICTRL pin is now connected to a voltage-divider from VCC to ground. Adjusting R2 allows programming the LED current from 0 to 1.1A.
	Open	Disconnects the ICTRL pin of the device from the external voltage-divider on the VCC pin. Allows the user to apply an external voltage to set the LED current level.
J3	1-2*	Connects the $\overline{\text{FLT}}$ pin to VCC through a 10kΩ resistor.
	Open	No pullup on $\overline{\text{FLT}}$ pin.
J4	Open*	PWMDIM pin is controlled by the jumper J1 setting only.
	1-2*	Analog voltage on PWMDIM pin controlled by the voltage-divider of R13 and R18. Adjust R18 to vary the analog voltage on PWMDIM. Jumper J1 should be in default position.

*Default position.

Analog Dimming Control (ICTRL)

When J2 is installed across pins 1-2, the LED current is set at the maximum current. The ICTRL pin is connected to VCC and in this case, the LED current is given by the following equation:

$$I_{\text{LED}} = \frac{220\text{mV}}{R14}$$

When J2 is installed across pins 2-3, the ICTRL pin is connected to the voltage-divider of R1 and R2, which sets the voltage at ICTRL.

In the case of the EV kit, I_{LED} is set to 1A. If $V_{\text{ICTRL}} < 1.2\text{V}$, then V_{ICTRL} sets the LED current level.

Alternatively, the analog dimming can be controlled by removing the shunt on J2 and applying a voltage between 0 and 5.5V on the ICTRL PCB pad on the EV kit.

Pulse-Dimming Input (PWMDIM)

Pulse dimming can be achieved by applying a pulsating voltage source on the PWMDIM PCB pad on the EV kit. When PWMDIM is pulled low, $\overline{\text{DIMOUT}}$ is pulled high and the pulse-width-modulated (PWM) switching is disabled.

This can be done by installing the shunt on J1 across pins 2-3, without applying any external voltage on the PWMDIM PCB pad. The PWMDIM pin can also be controlled by an analog DC voltage on the PWMDIM pin. In this case, the dimming frequency is internally set at 200Hz. This can be achieved by installing the shunt on J1 across pins 1-2, the shunt on J4 installed across pins 1-2, and adjusting potentiometer R18. The dimming duty cycle can be adjusted from 0 to 100% duty cycle by adjusting the voltage on the PWMDIM pin from 0.2V to 3.25V.

Alternatively, PWM dimming can be achieved by applying a DC voltage between 0.2V and 3.3V on the PWMDIM PCB pad, with J1 and J4 open.

Ordering Information

PART	TYPE
MAX20090EVKIT#	EV Kit

#Denotes RoHS compliant.

MAX20090 EV Kit Component List

PART	QTY	DESCRIPTION
C1, C6, C9	3	1uF ±10%, 16V X7R ceramic capacitors (0603)
C2, C7, C8, C10	4	0.1uF ±10%, 50V X7R ceramic capacitors (0603)
C3, C14	2	0.01uF ±10%, 100V X7R ceramic capacitors (0603)
C4, C5, C11–C13, C15	6	4.7uF ±10% 100V X7R ceramic capacitors (1210) TDK CGA6M3X7S2A475K200AE
C16	1	0.022uF ±10%, 100V X7R ceramic capacitors (0603)
C17	1	1000pF ±5%, 50V C0G ceramic capacitor (0603) Murata GRM1885C1H102FA01
C18	0	Not installed capacitor (0603)
D1	1	100V, 3A Schottky diode (SMC) Diodes Inc. B3100-13-F
D2	0	Not installed diode
J1, J2	2	3 pin headers
J3, J4	2	2 pin headers
L1	1	10uH, 5.7A ferrite core inductor Coilcraft MSS1278-103ML
Q1	1	100V, 42A n-channel MOSFET (DPAK) International Rectifier IRLR3110ZPbF
Q2	1	80V, 2.1A p-channel MOSFET (SSOT-6) Fairchild Semiconductor FDC3535
Q3	1	Small signal pnp transistor (SOT23) Fairchild Semiconductor MMBT2907A
R1	1	24.9k ±1% resistor (0603)
R2, R18	2	10k potentiometers (9.53mmx4.83mmx10.03mm)
R3	1	40.2k ±1% resistor (0603)
R4	1	12.4k ±1% resistor (0603)
R5	1	86.6k ±1% resistor (0603)
R6	1	18.2 ±1% resistor (0603)
R7	1	2.49k ±1% resistor (0603)
R8, R16, R17	3	0ohm jumpers (0603)
R9	1	0.025 ±1% sense resistor (2512) Vishay Dale WSL2512R0250F
R10	1	475k ±1% resistor (0603)
R11, R12	2	10.0k ±1% resistors (0603)
R13	1	4.99k ±1% resistor (0603)
R14	1	0.2 ±1% sense resistor (2512) Vishay Dale WSL2512R2000F
R15	1	1.00k ±1% resistor (0603)
R19, R20	2	499k ±1% resistors (0603)
U1	1	Automotive High Voltage LED Controller (20 TQFN-EP) Maxim MAX20090ATP/V+
—	3	Shunts
—	1	PCB: MAX20090 EVALUATION KIT

MAX20090 EV Kit Schematics

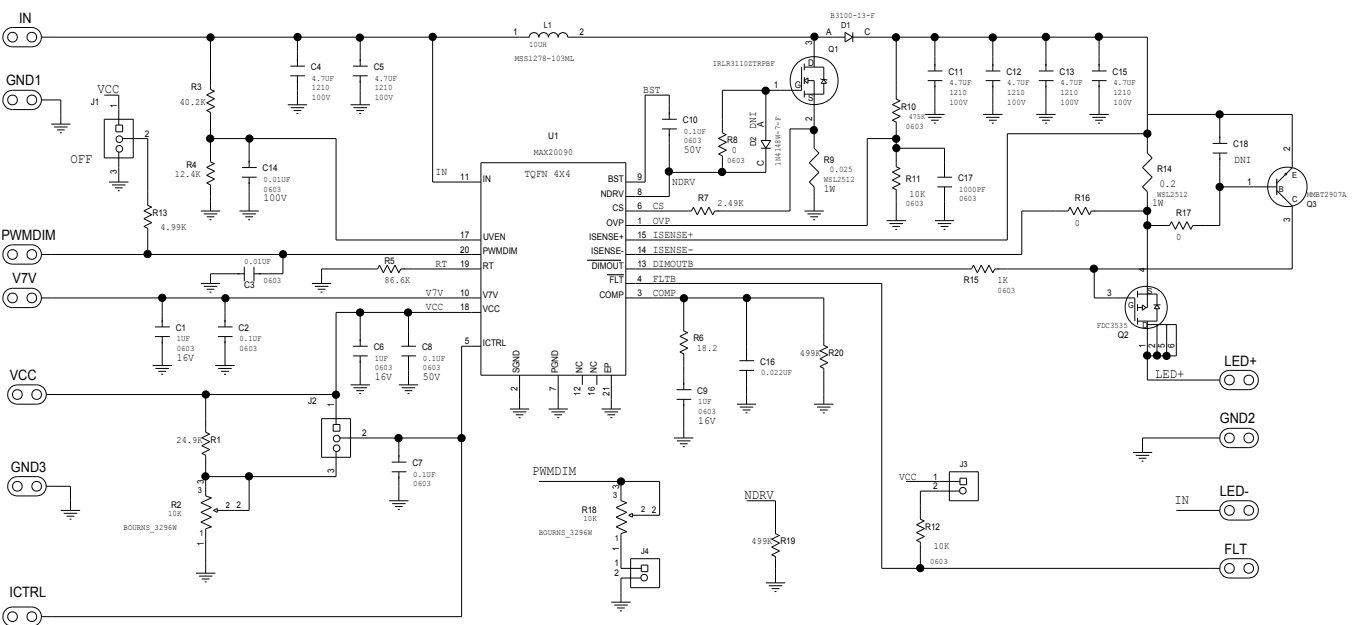

MAX20090 EV Kit PCB Layouts

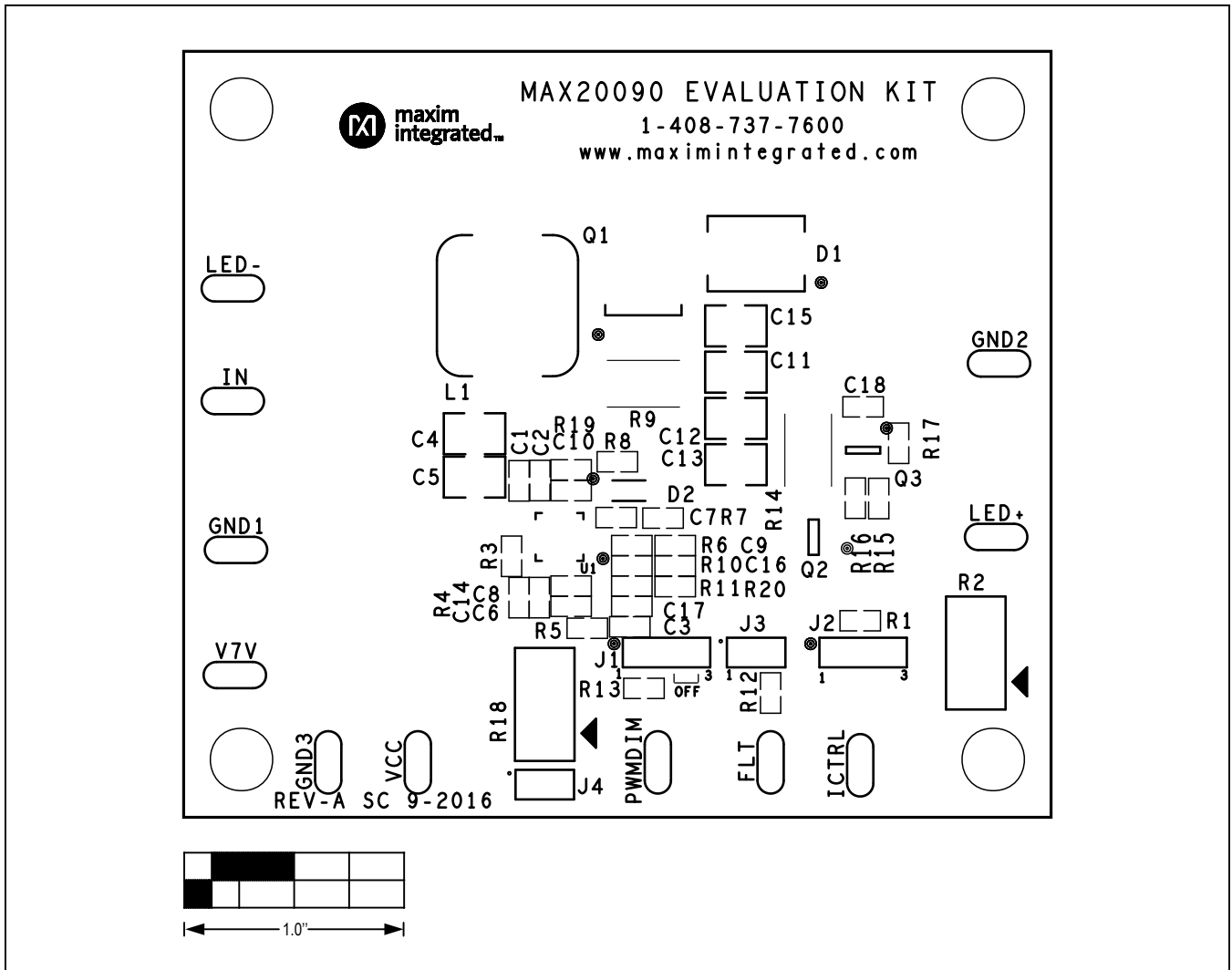

Component Placement Guide—Top

MAX20090 EV Kit PCB Layouts (continued)

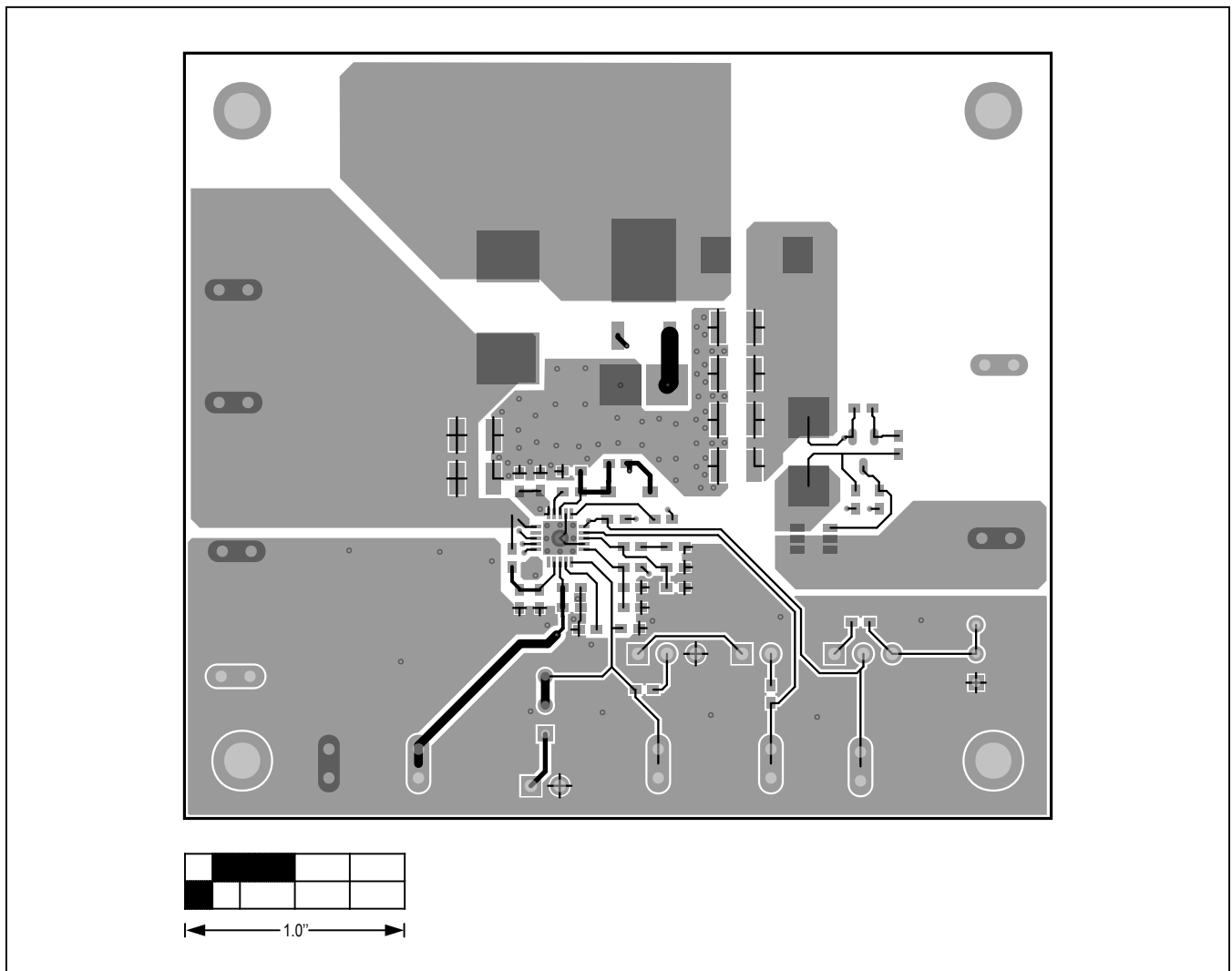

PCB Layout—Top

MAX20090 EV Kit PCB Layouts (continued)

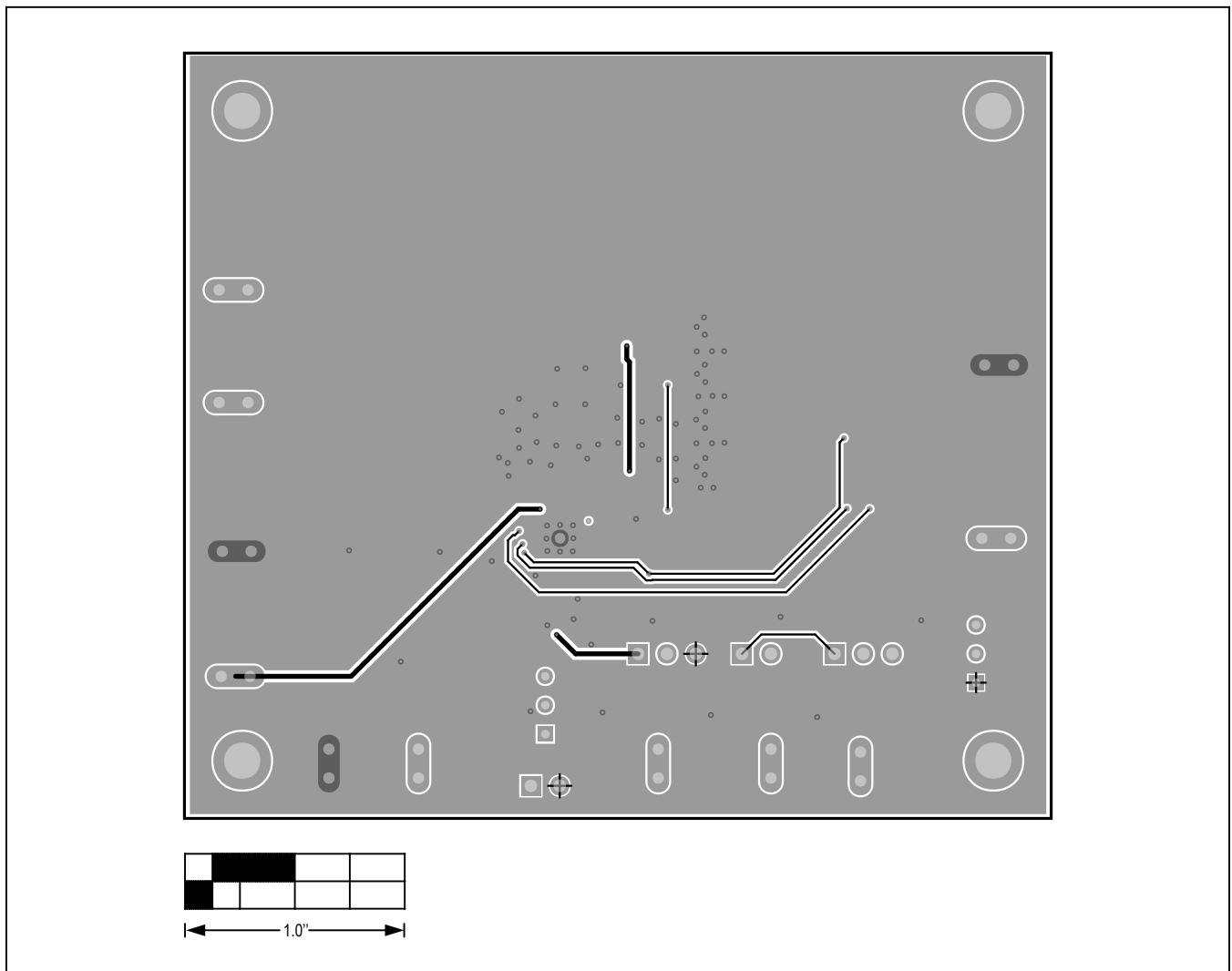

PCB Layout—Bottom

Revision History

REVISION NUMBER	REVISION DATE	DESCRIPTION	PAGES CHANGED
0	12/16	Initial release	—

For pricing, delivery, and ordering information, please contact Maxim Direct at 1-888-629-4642, or visit Maxim Integrated's website at www.maximintegrated.com.

Maxim Integrated cannot assume responsibility for use of any circuitry other than circuitry entirely embodied in a Maxim Integrated product. No circuit patent licenses are implied. Maxim Integrated reserves the right to change the circuitry and specifications without notice at any time.