



Chipsmall Limited consists of a professional team with an average of over 10 year of expertise in the distribution of electronic components. Based in Hongkong, we have already established firm and mutual-benefit business relationships with customers from,Europe,America and south Asia,supplying obsolete and hard-to-find components to meet their specific needs.

With the principle of “Quality Parts,Customers Priority,Honest Operation,and Considerate Service”,our business mainly focus on the distribution of electronic components. Line cards we deal with include Microchip,ALPS,ROHM,Xilinx,Pulse,ON,Everlight and Freescale. Main products comprise IC,Modules,Potentiometer,IC Socket,Relay,Connector.Our parts cover such applications as commercial,industrial, and automotives areas.

We are looking forward to setting up business relationship with you and hope to provide you with the best service and solution. Let us make a better world for our industry!



Contact us

Tel: +86-755-8981 8866 Fax: +86-755-8427 6832

Email & Skype: info@chipsmall.com Web: www.chipsmall.com

Address: A1208, Overseas Decoration Building, #122 Zhenhua RD., Futian, Shenzhen, China



General Description

The MAX2248 evaluation kit (EV kit) simplifies evaluation of the MAX2248 power amplifier (PA). It enables testing of the device's RF performance and requires no additional support circuitry. The EV kit's signal inputs and outputs use SMA connectors to facilitate the connection of RF test equipment.

The MAX2248 EV kit is assembled with a MAX2248 and incorporates output-matching components optimized for 1880Mhz to 1930MHz.

Features

- Easy Evaluation of the MAX2248
- +2.7V to +5V Single-Supply Operation
- RF Output Matched for Operation from 1880MHz to 1930MHz
- Jumpers for Digital Power Control and Shutdown
- All Critical Peripheral Components Included

Ordering Information appears at end of data sheet.

EV Kit Photo

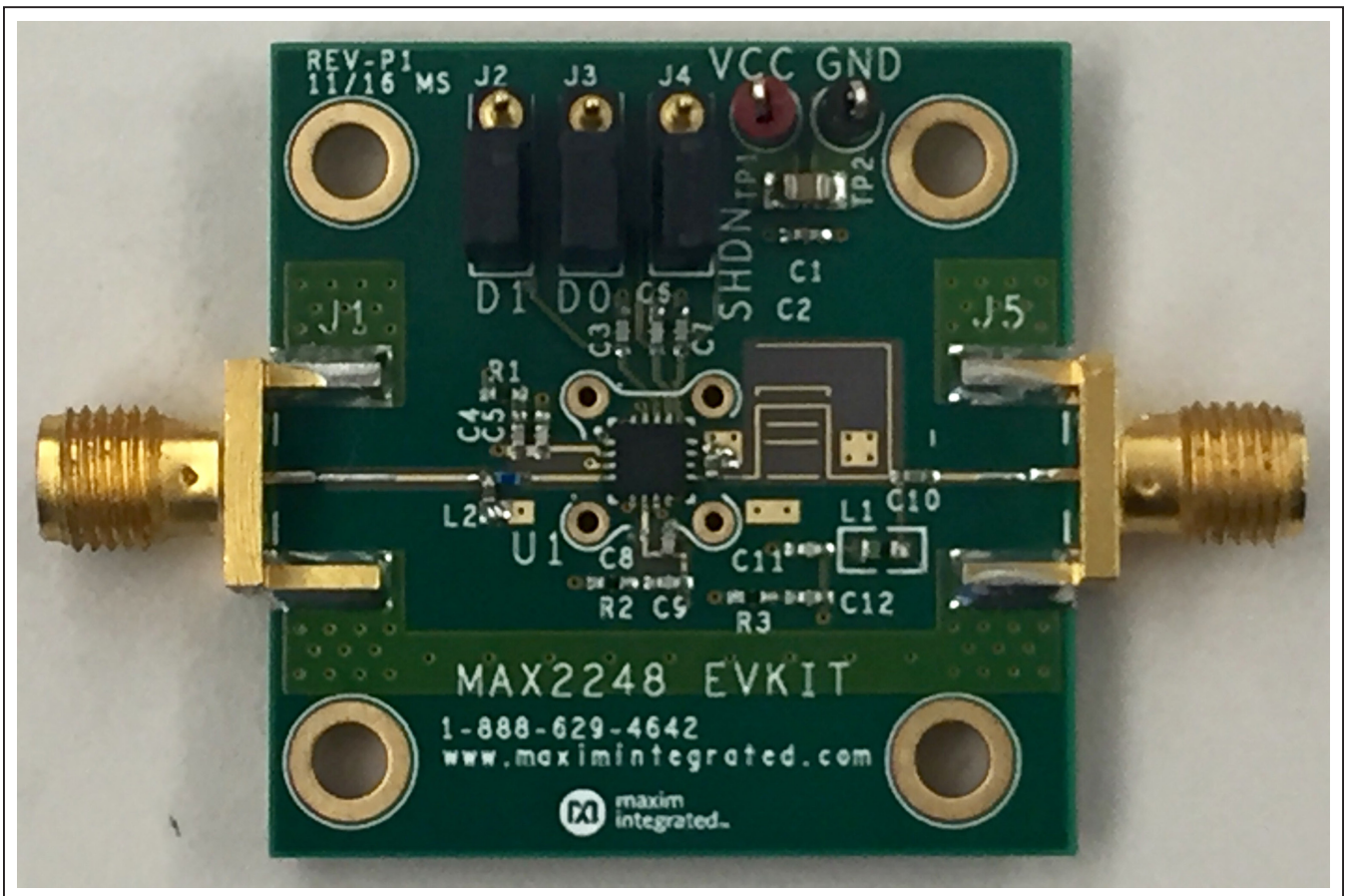

Quick Start

The MAX2248 EV kit is fully assembled and factory tested. Follow the instructions in the Connections and Setup Section for proper device evaluation.

Required Equipment

This section lists the recommended test equipment to verify operation of the MAX2248. It is intended as a guide only, and some substitutions are possible:

- One RF signal generator capable of delivering at least +5dBm of output power at the operating frequency (HP 8648D, or equivalent)
- One RF power sensor capable of handling at least +20dBm of output power at the operating frequency (HP 8482A, or equivalent)
- One RF power meter capable of measuring up to +20dBm of output power at the operating frequency (HP 438A, or equivalent)
- An RF spectrum analyzer that covers the MAX2248 operating frequency range, as well as a few harmonics (HP 8562E, for example)
- A power supply capable of up to 0.25A at +2.7V to +5V
- An optional ammeter for measuring the supply current
- Two 50Ω SMA cables
- One SMA 20dB pad
- A network analyzer (HP 8753D, for example) to measure small-signal return loss and gain (optional)

Procedure

This section provides a step-by-step guide to operating the EV kit and testing the device’s function. Do not turn on the DC power or RF signal generators until all connections are made:

- 1) Connect a DC supply set to +3.2V (through an ammeter if desired) to the VCC and GND terminals on the EV kit. Do not turn on the supply.

- 2) Connect one RF signal generator to J1 (RFIN) SMA Connector on the EV Kit; do not turn on the generator’s output.
Set the generator for an output frequency of 1900MHz at a power level of +3dBm.
- 3) Connect a 20dB pad to J2 (RFOUT) SMA Connector on the EV Kit. This is to prevent overloading of the power sensor and the power meter.
- 4) Connect a power sensor to the 20dB pad.
- 5) Connect the power sensor to a power meter. Set the power meter offset to 20dB and frequency to 1900MHz.
- 6) Connect jumpers J2, J3, and J4 to short D1, D0, and SHDN to VCC. This sets the MAX2248 to its highest power mode. The MAX2248 EV kit is shipped in this setting.
- 7) Turn on the DC supply.
- 8) Activate the RF generator’s output. The power meter should read approximately +20dBm. The supply current should increase to approximately 105mA.
- 9) Another method for determining gain is by using a network analyzer (optional). This has the advantage of displaying gain versus a swept-frequency band, in addition to displaying input return loss. Refer to the network analyzer manufacturer’s user manual for setup details.
- 10) The additional MAX2248 power modes are set by the jumper settings of J2 (D1) and J3 (D0). See [Table 1](#) belowin for these power level settings.

Layout Considerations

A good PC board is an essential part of an RF circuit design. The EV kit PC board can serve as a guide for laying out a board using the MAX2248. Keep traces carrying RF signals as short as possible to minimize radiation and insertion loss due to the PC board. Each VCC node on the PC board should have its own decoupling capacitor. This minimizes supply coupling from one section of the IC to another. A star topology for the supply layout, in which each VCC node on the circuit has a separate connection to a central VCC node, can further minimize coupling between sections of the IC. See the Layout section of the MAX2248 data sheet for more information.

Table 1. Control Inputs

DIGITAL CONTROL INPUTS			OUTPUT POWER AND SUPPLY CURRENT			
/SHDN	D1	D0	POWER LEVE	PIN (dBm)	POUT (dBm)	ICC (mA)
0	0	0	PA OFF	+3	-	<1μA
1	0	0	P1	+3	+4	73
1	0	1	P2	+3	+12	76
1	1	0	P3	+3	+18	82
1	1	1	P4	+3	+20	105

Component Suppliers

SUPPLIER	WEBSITE
Murata	www.murata.com
TDK	www.tdk.com
Keystone Electronics	www.keyelco.com
Johnson Components (Cinch Connectivity Solutions)	www.cinchconnectivity.com
Kamaya	www.kamaya.com
Kemet	www.kemet.com
Mill-Max	www.mill-max.com
Sullins Electronics Corps.	www.DigiKey.com/Sullins
Toko	www.tokoam.com

Note: Indicate that you are using the MAX2248 when contacting these component suppliers.

Ordering Information

PART	TYPE
MAX2248EVKIT#	EV Kit, 1880MHz-1980MHz

#Denotes RoHS compliant.

MAX2248 EV Kit Bill of Materials

Item	Reference	Quantity	Value	Tolerance	Description	Part Number	Manufacturer
1	C1	1	1UF	±10%	0805 Ceramic Capacitor, SMT	GRM21BR71C105KA01	MURATA
2	C2	1	0.01UF	±10%	0402 Ceramic Capacitor, SMT	C0402C103K3RAC; GRM155R71E103KA01D; C1005X7R1E103K	KEMET; MURATA; TDK
3	C3, C6, C7	3	470PF	±5%	0402 Ceramic Capacitor, SMT	GCM1555C1H471JA16; GRM1555C1H471JA01	MURATA
4	C4, C9, C12	3	1000PF	±5%	0402 Ceramic Capacitor, SMT	GRM1555C1H102JA01; C1005C0G1H102J050	MURATA; TDK
5	C5, C11	2	220PF	±5%	0402 Ceramic Capacitor, SMT	GRM1555C1H221JA01	MURATA
6	C8	1	18PF	±5%	0402 Ceramic Capacitor, SMT	C0402C180J5GAC; GRM1555C1H180JA01J;C100 5C0G1H180J050	KEMET/MURATA/ DK
7	C10	1	8PF	±0.25pF	0402 Ceramic Capacitor, SMT	GRM1555C1H8R0CZ01D	MURATA
8	C13	1	1PF	±0.05pF	0402 Ceramic Capacitor, SMT	GJM1555C1H1R0WB01	MURATA
9	C14	1	1PF		0201 Ceramic Capacitor, SMT	GRM0334C1H1R0WA01	MURATA
12	L1	1	22NH	±10%	0603 Ceramic Inductor, SMT	LQG18HN22NJ00	MURATA
13	L2	1	1.5NH	±0.2nH	0402 Wirewound Inductor, SMT	LQW15AN1N5C00	MURATA
14	R1-R3	3	8.2	±5%	0402 Thick Film Resistor	RMC1/16S-8R2J	KAMAYA
10	J1, J5	2	142-0701-851		2 pin Connector, End Launch Jack Receptacle	142-0701-851	JOHNSON COMPONENTS
11	J2-J4	3	HEADER_3P		3 pin Connector, Male, Through Hole	800-10-003-10-001000	MILLMAX
15	SU2-SU4	3	STC02SYAN		2 (1 x 2) Position Shunt Connector Black	STC02SYAN	SULLINS ELECTRONICS CORP.
16	TP1	1	N/A		Test Point, Red	5000	KEYSTONE
17	TP2	1	N/A		Test Point, Black	5001	KEYSTONE
18	U1	1	MAX2248		MAX2248, 16 TQFN-EP; PACKAGE CODE T1633+5	MAX2248	MAXIM

MAX2248 EV Kit Schematic

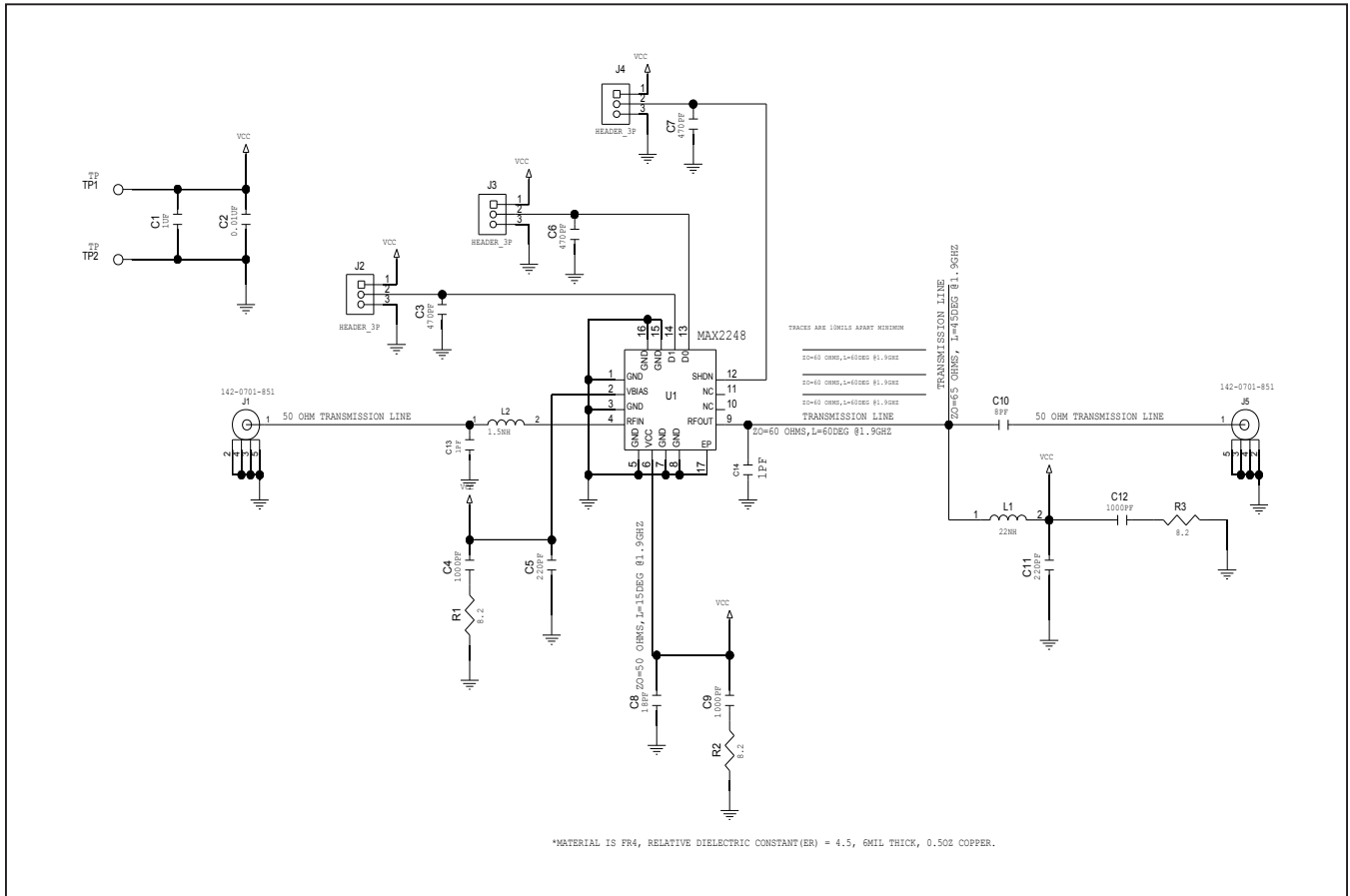

MAX2248 EV Kit PCB Layout Diagrams

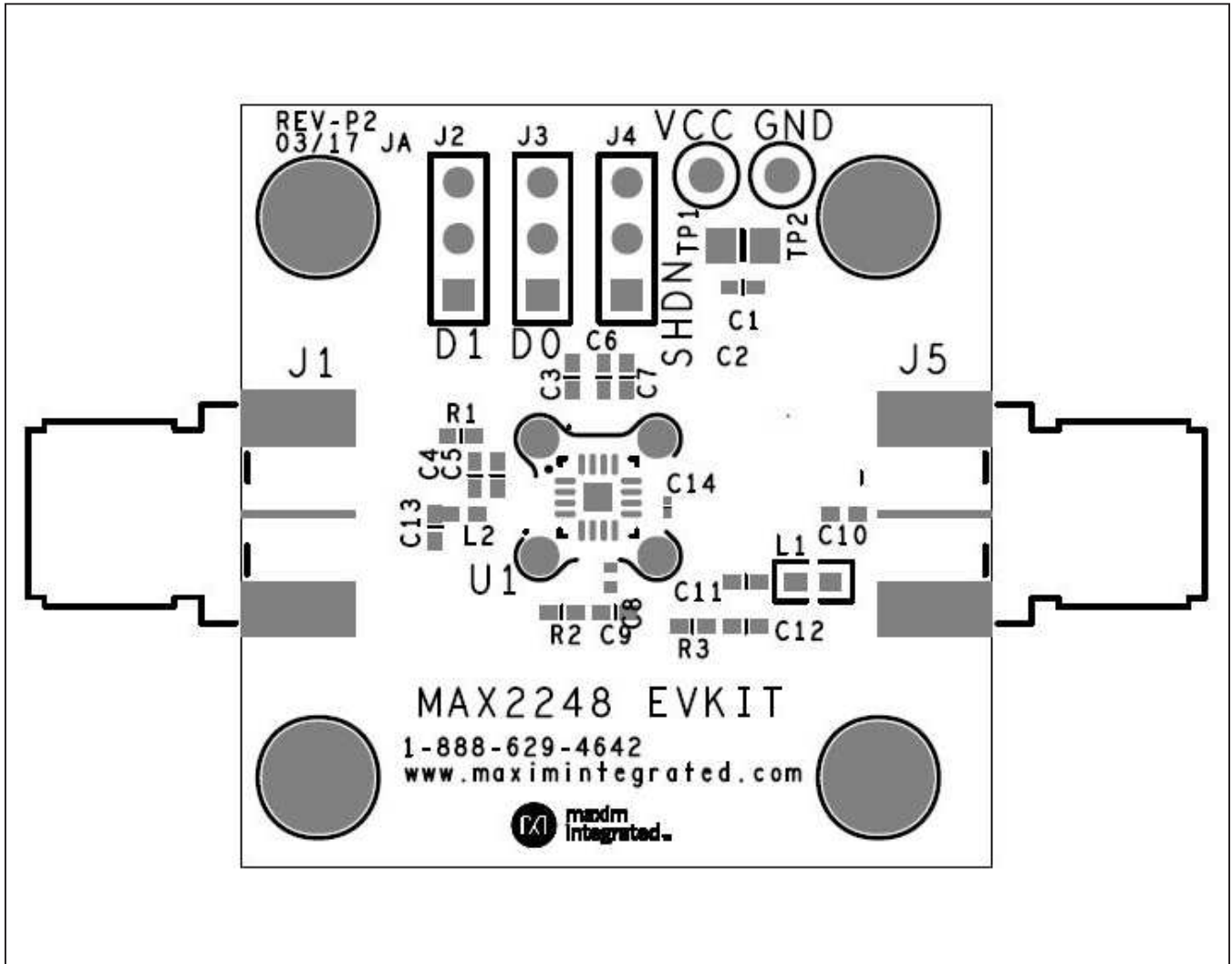

MAX2248 EV Kit—Gerber Top Silkscreen

MAX2248 EV Kit PCB Layout Diagrams (continued)

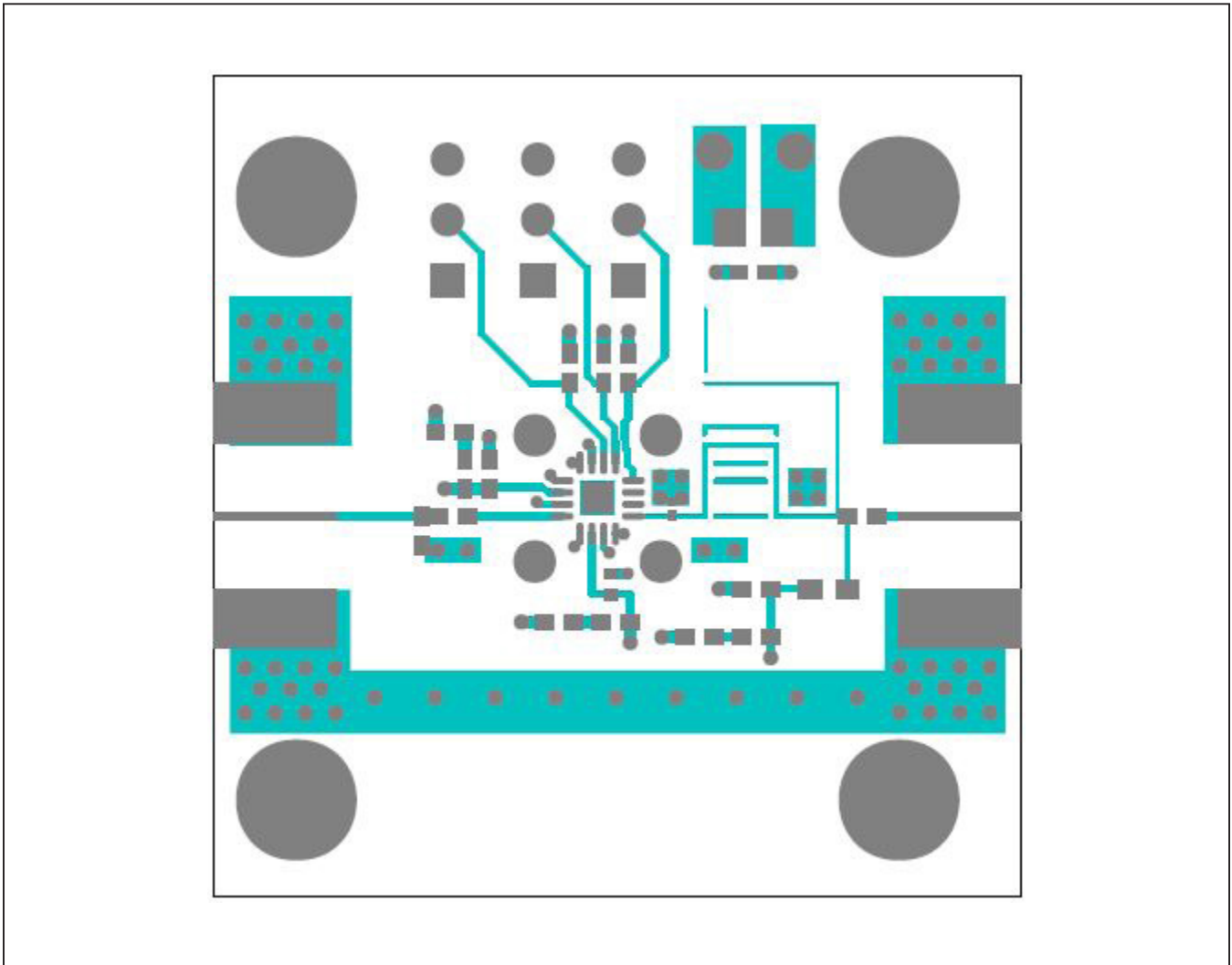

MAX2248 EV Kit—Gerber Top

MAX2248 EV Kit PCB Layout Diagrams (continued)

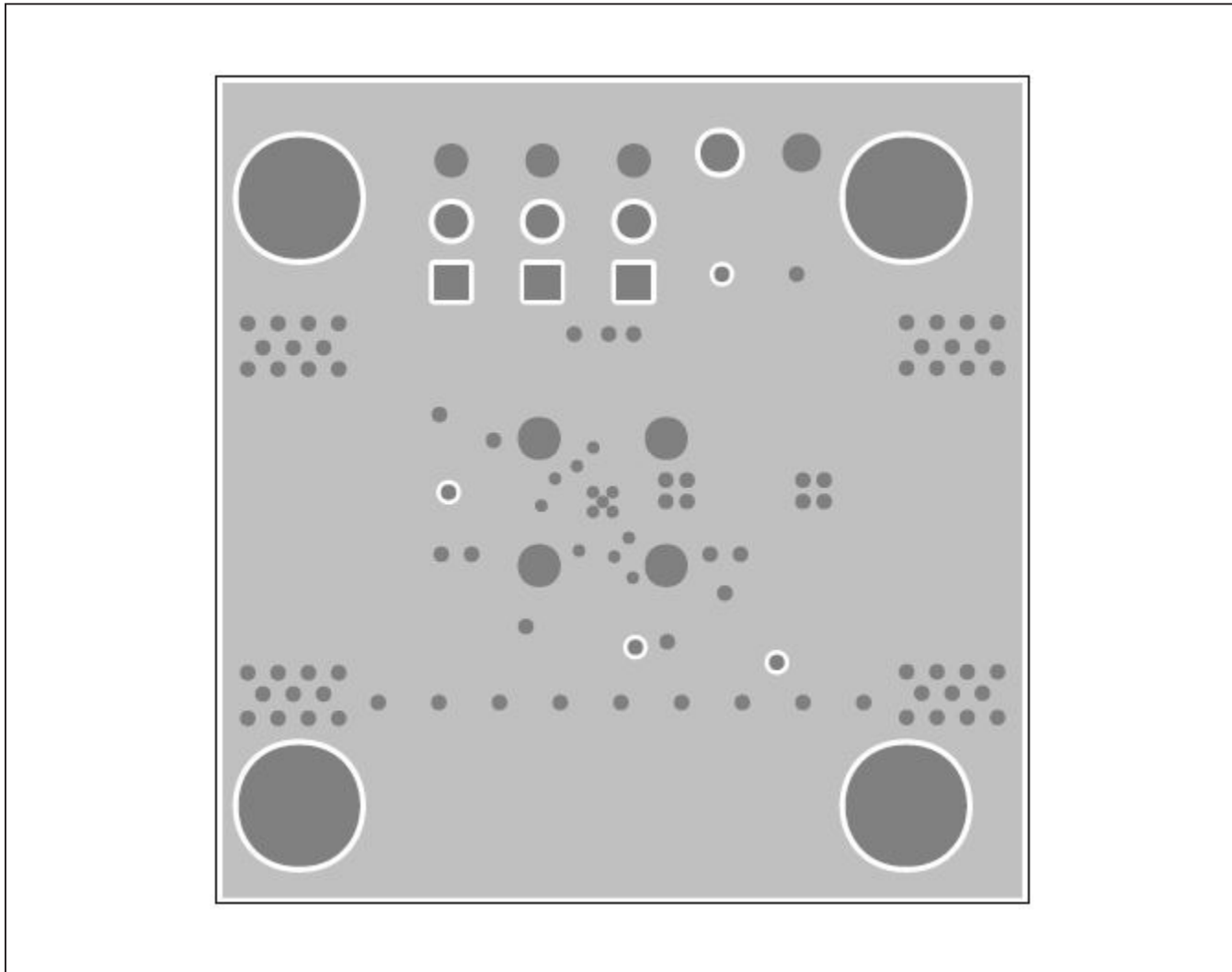

MAX2248 EV Kit—Gerber Level 2 GND

MAX2248 EV Kit PCB Layout Diagrams (continued)

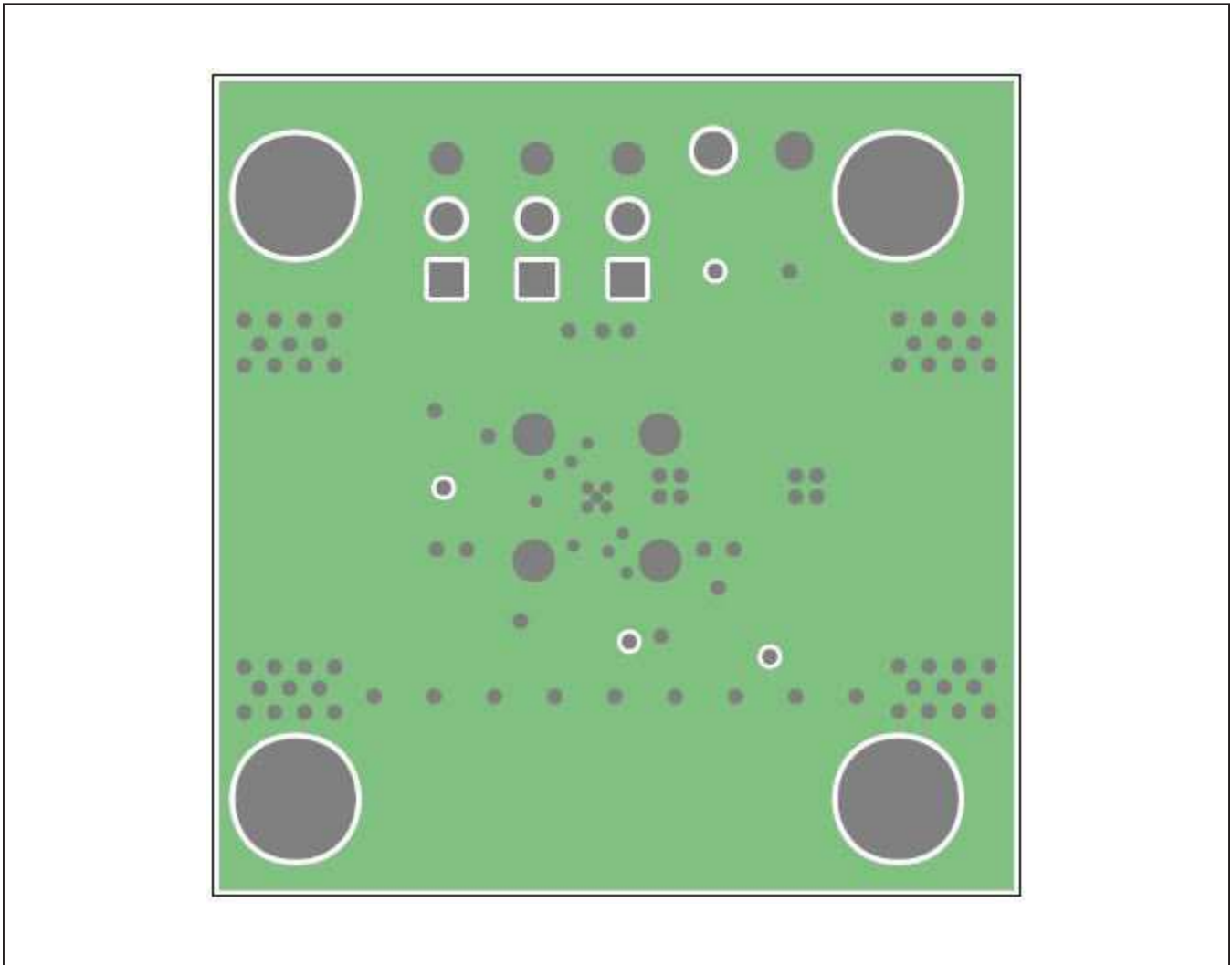

MAX2248 EV Kit—Gerber Level 3 Power

MAX2248 EV Kit PCB Layout Diagrams (continued)

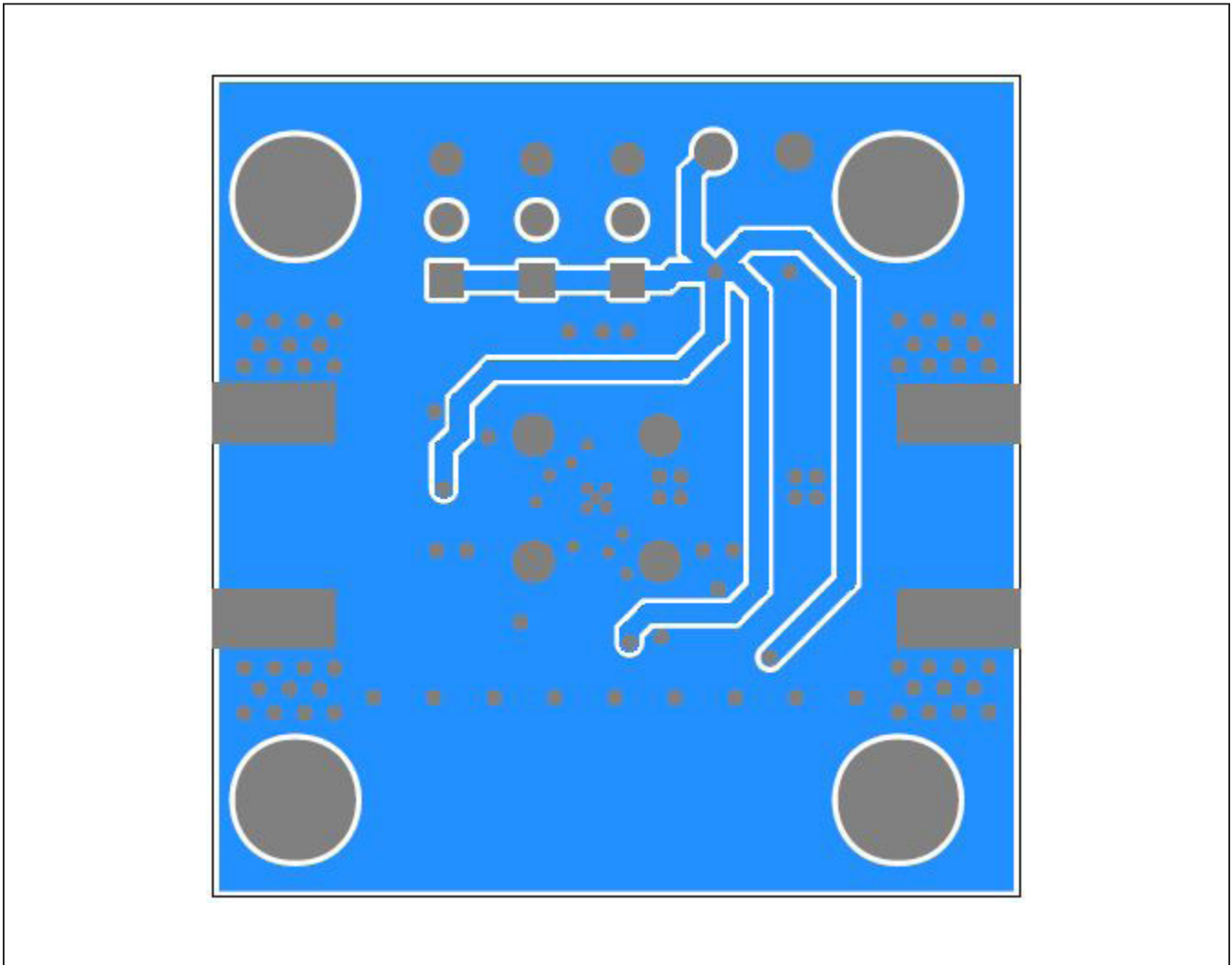

MAX2248 EV Kit—Gerber Bottom

MAX2248 EV Kit PCB Layout Diagrams (continued)

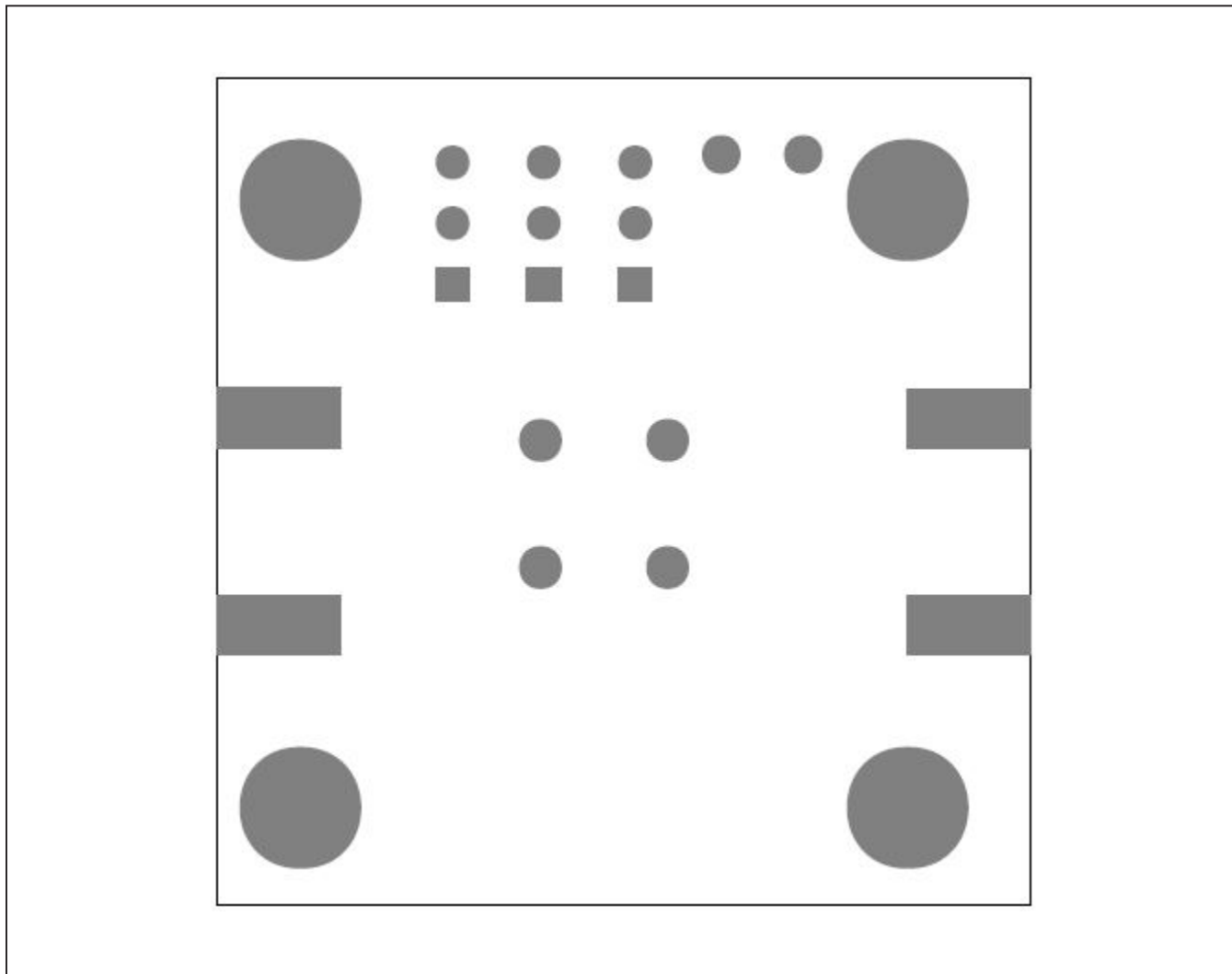

MAX2248 EV Kit—Gerber Bottom Silkscreen

MAX2248 EV Kit PCB Layout Diagrams (continued)

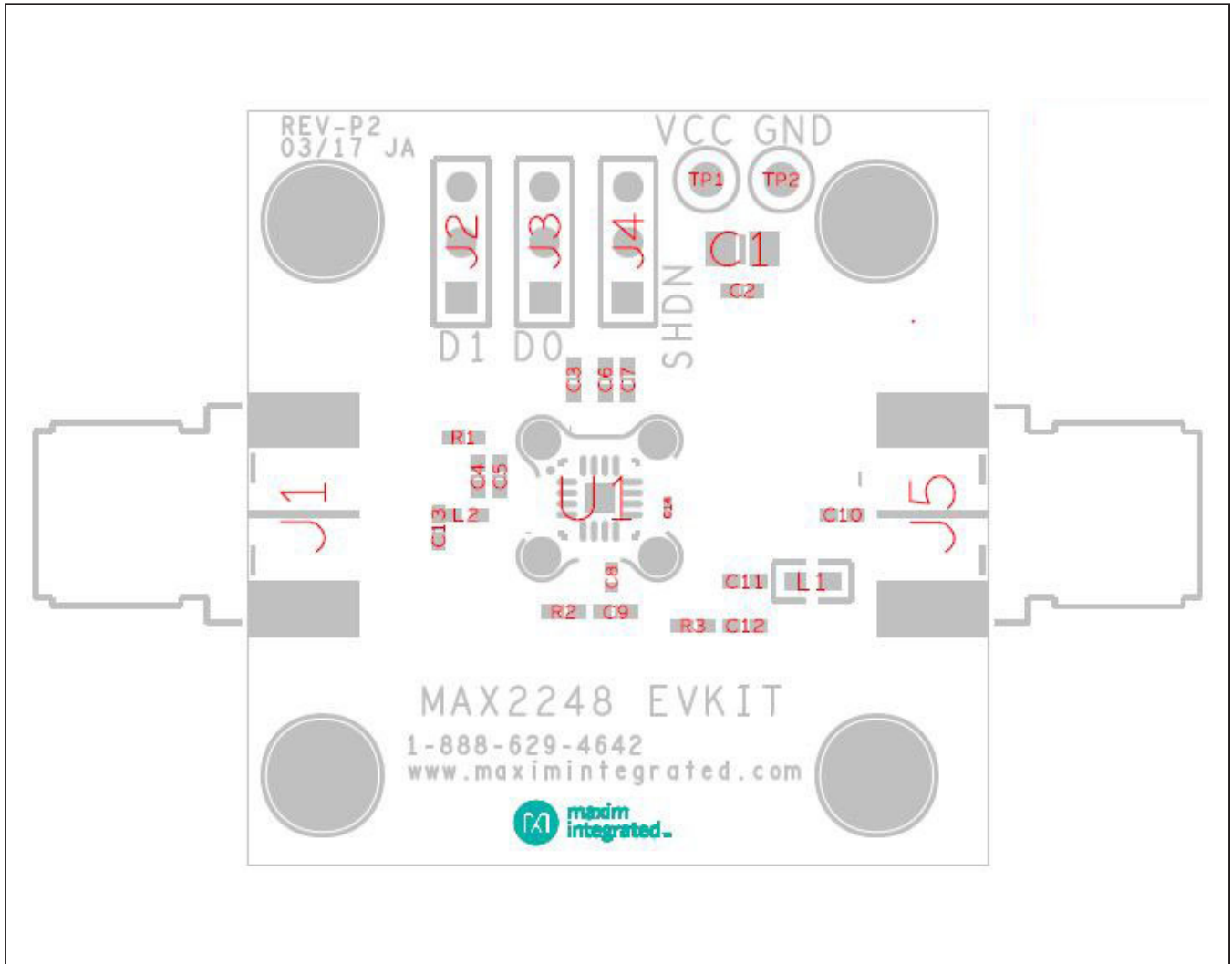

MAX2248 EV Kit—Assembly Top

Revision History

REVISION NUMBER	REVISION DATE	DESCRIPTION	PAGES CHANGED
0	6/17	Initial release	—
1	7/17	Updated <i>Ordering Information</i> table	3

For pricing, delivery, and ordering information, please contact Maxim Direct at 1-888-629-4642, or visit Maxim Integrated's website at www.maximintegrated.com.

Maxim Integrated cannot assume responsibility for use of any circuitry other than circuitry entirely embodied in a Maxim Integrated product. No circuit patent licenses are implied. Maxim Integrated reserves the right to change the circuitry and specifications without notice at any time.