



Chipsmall Limited consists of a professional team with an average of over 10 year of expertise in the distribution of electronic components. Based in Hongkong, we have already established firm and mutual-benefit business relationships with customers from,Europe,America and south Asia,supplying obsolete and hard-to-find components to meet their specific needs.

With the principle of “Quality Parts,Customers Priority,Honest Operation,and Considerate Service”,our business mainly focus on the distribution of electronic components. Line cards we deal with include Microchip,ALPS,ROHM,Xilinx,Pulse,ON,Everlight and Freescale. Main products comprise IC,Modules,Potentiometer,IC Socket,Relay,Connector.Our parts cover such applications as commercial,industrial, and automotives areas.

We are looking forward to setting up business relationship with you and hope to provide you with the best service and solution. Let us make a better world for our industry!



## Contact us

Tel: +86-755-8981 8866 Fax: +86-755-8427 6832

Email & Skype: info@chipsmall.com Web: www.chipsmall.com

Address: A1208, Overseas Decoration Building, #122 Zhenhua RD., Futian, Shenzhen, China



# MAX2686L/MAX2693L Evaluation Kit

Evaluates: MAX2686L/MAX2693L

## General Description

The MAX2686L/MAX2693L evaluation kits (EV kits) simplify the evaluation of the MAX2686L/MAX2693L GPS/GNSS low-noise amplifiers (LNAs). They enable testing of the device's RF performance and require no additional supporting circuitry. The EV kits provide 50Ω SMA connectors for inputs and outputs.

## Features

- Easy Evaluation of MAX2686L/MAX2693L IC
- 1.6V to 4.2V Single-Supply Operation
- RF Input and Output Matched to 50Ω
- Fully Assembled and Tested

[Ordering Information](#) appears at end of data sheet.

## Quick Start

The MAX2686L/MAX2693L EV kits are fully assembled and factory tested. Follow the instructions in the [Connections and Setup](#) section to test the devices.

## Required Equipment

This section lists the recommended test equipment to verify the operation of the MAX2686L/MAX2693L. The equipment's listed are intended as suggestions and substitutions are possible:

- MAX2686L/MAX2693L EV kit
- One DC power supply capable of delivering +2.85V and 50mA of current
- One RF signal generator capable of delivering RF power as high as 0dBm at 1575.42MHz (E4433B or equivalent)
- One RF spectrum analyzer that covers the MAX2686L/MAX2693L operating frequency range (FSEB20 or equivalent)
- One power meter capable of measuring up to 0dBm at 1575.42MHz (Agilent E4419B or equivalent)
- Two 50Ω SMA cables
- One ammeter (optional)
- One noise figure meter (optional)
- One network analyzer (optional)

### Connections and Setup

This section is a step-by-step guide to operating the EV kits and describes their function. **Caution: Do not turn on the DC power or RF signal generators until all connections are completed.**

#### Checking Power Gain

- 1) With the DC supply output disabled, connect a +2.85V power supply to the V<sub>CC</sub> header and the power supply ground the GND header of the EV kit (route the positive terminal of the power supply through an ammeter, if desired).
- 2) Place a jumper between pins 2 and 3 on SHDNB (pin 1 closet to the R<sub>F</sub>OUT SMA port).
- 3) With the RF signal generator output disabled, connect the generator output to the R<sub>F</sub>IN SMA connector on the EV kit through an SMA cable. Set the output of the RF signal generator frequency to 1575.42MHz and power level to -25dBm.

- 4) Connect a spectrum analyzer to the R<sub>F</sub>OUT SMA connector on the EV kit through an SMA cable. Set the spectrum analyzer center frequency to 1575.42MHz, reference level to 0dBm, and span to 1MHz.
- 5) Enable the DC supply output. The supply current should read approximately 1.8mA.
- 6) Enable the RF signal generator output. The spectrum analyzer should displays a tone at 1575.42MHz with power level at approximately -7dBm.

### Layout Issues

A good printed circuit board (PCB) is an essential part of RF circuit design. The EV kit PCB can serve as a guide for laying out a board using the MAX2686L/MAX2693L. Use controlled impedance lines on all high-frequency inputs and outputs. Bypass V<sub>CC</sub> with decoupling capacitors located close to the device. For long V<sub>CC</sub> lines, it may be necessary to add decoupling capacitors. Positioning these additional capacitors farther away from the device package minimizes supply coupling. Proper grounding of the GND pins is essential. Connect the GND pins to the ground plane either directly, with throughputs, or both.

### Component Suppliers

SUPPLIER	WEBSITE
AVX/Kyocera	www.avx.com
Digi-Key	www.digikey.com
Johnson/Cinch Connectivity Solutions	www.johnsoncomponents.com
Keystone	www.keyelco.com

**Note:** Indicate that you are using the MAX2686L/MAX2693L when contacting these component suppliers.

### Component Information, PCB Layout, and Schematics

See the following links for component information, PCB layout diagrams, and schematics.

- [MAX2686L EV BOM](#)
- [MAX2693L EV BOM](#)
- [MAX2686L/MAX2693L EV PCB Layout](#)
- [MAX2686L EV Schematic](#)
- [MAX2693L EV Schematic](#)

### Ordering Information

PART	TYPE
MAX2686LEVKIT#	EV Kit
MAX2693LEVKIT#	EV Kit

## Revision History

REVISION NUMBER	REVISION DATE	DESCRIPTION	PAGES CHANGED
0	3/16	Initial release	—

For pricing, delivery, and ordering information, please contact Maxim Direct at 1-888-629-4642, or visit Maxim Integrated's website at [www.maximintegrated.com](http://www.maximintegrated.com).

*Maxim Integrated cannot assume responsibility for use of any circuitry other than circuitry entirely embodied in a Maxim Integrated product. No circuit patent licenses are implied. Maxim Integrated reserves the right to change the circuitry and specifications without notice at any time.*

<b>EVKit Part Number: MAX2686LEVKIT#</b>							
<b>Revision: A</b>							
<b>Date Last Edited: 3-28-12</b>							
<b>Associated schematic: 2686L_A</b>							
<b>Associated Layout: 2686L_A</b>							
Item	Reference	Qty	Value	Tolerance	Description	Manufacturer	Part Number
1	C1	1	39pF	5%	0402 Capacitor	Murata	GRM1555C1H390J
2	C2	1	0.1uF	10%	0402 Capacitor	Murata	GRM155R71C104K
3	C3	1	10pF	5%	0402 Capacitor	Murata	GRM1555C1H100J
4	C4	1	10uF	10%	Tantalum Capacitor - 'C' Case	AVX	TAJC106K016
5	C13	1	100pF	5%	0402 Capacitor	Murata	GRM1555C1H101J
6	R6	1	24.9K	1%	0402 Resistor		Use Lead Free Only
7	L1	1	7.3nH	3%	0402 Inductor	Murata	LQW15AN7N3H00
8	U1	1	MAX2686L		GPS LNA	Maxim Integrated Products	MAX2686LEWS+
9	RFIN RFOUT	2	Connector		SMA End Launch Jack Receptacle	Johnson	142-0701-851
10	SHDNB	1	1X3 Pin Header		Single In-Line Header, 100 mil center	Sullins	PEC36SAAN
11	VCC	1	Test Point		PC Mini-Red	Keystone	5000
12	GND	1	Test Point - Black		PC Mini-Black	Keystone	5001
	Pack-Out BOM						
13		1			Brown Box 9 3/16" x 7" x 7/8"		
14		1			ESD Bag 4" x 6" w/ESD Logo		
15		1			Pink Foam 12" x 12" x 5MM		
16		1			Web Instructions		

<b>EVKit Part Number: MAX2693LEVKIT#</b>							
<b>Revision: A</b>							
<b>Date Last Edited: 3-28-12</b>							
<b>Associated schematic: 2693L_A</b>							
<b>Associated Layout: 2693L_A</b>							
Item	Reference	Qty	Value	Tolerance	Description	Manufacturer	Part Number
1	C1	1	39pF	5%	0402 Capacitor	Murata	GRM1555C1H390J
2	C2	1	0.1uF	10%	0402 Capacitor	Murata	GRM155R71C104K
3	C3	1	10pF	5%	0402 Capacitor	Murata	GRM1555C1H100J
4	C4	1	10uF	10%	Tantalum Capacitor - 'C' Case	AVX	TAJC106K016
5	C13	1	100pF	5%	0402 Capacitor	Murata	GRM1555C1H101J
6	R6	1	24.9K	1%	0402 Resistor		Use Lead Free Only
7	L1	1	12nH	3%	0402 Inductor	Murata	LQW15AN12NH00
8	U1	1	MAX2693L		GPS LNA	Maxim Integrated Products	MAX2693LEWS+
9	RFIN RFOUT	2	Connector		SMA End Launch Jack Receptacle	Johnson	142-0701-851
10	SHDNB	1	1X3 Pin Header		Single In-Line Header, 100 mil center	Sullins	PEC36SAAN
11	VCC	1	Test Point		PC Mini-Red	Keystone	5000
12	GND	1	Test Point - Black		PC Mini-Black	Keystone	5001
	Pack-Out BOM						
13		1			Brown Box 9 3/16" x 7" x 7/8"		
14		1			ESD Bag 4" x 6" w/ESD Logo		
15		1			Pink Foam 12" x 12" x 5MM		
16		1			Web Instructions		



**GND**

**C4**



**VCC**

**SHDNB**

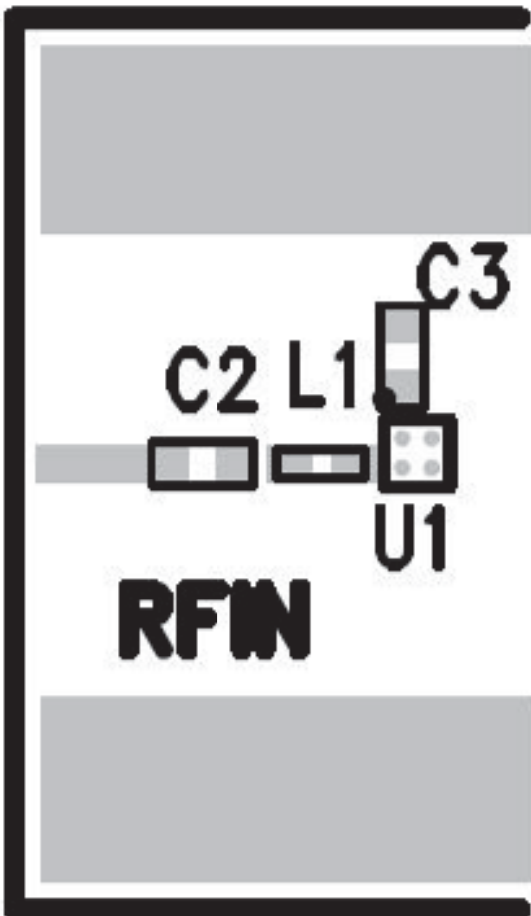

**RFIN**

**C2**

**L1**

**U1**

**C3**

**R6**

**C1**

**C7**

**C8**

**C13**

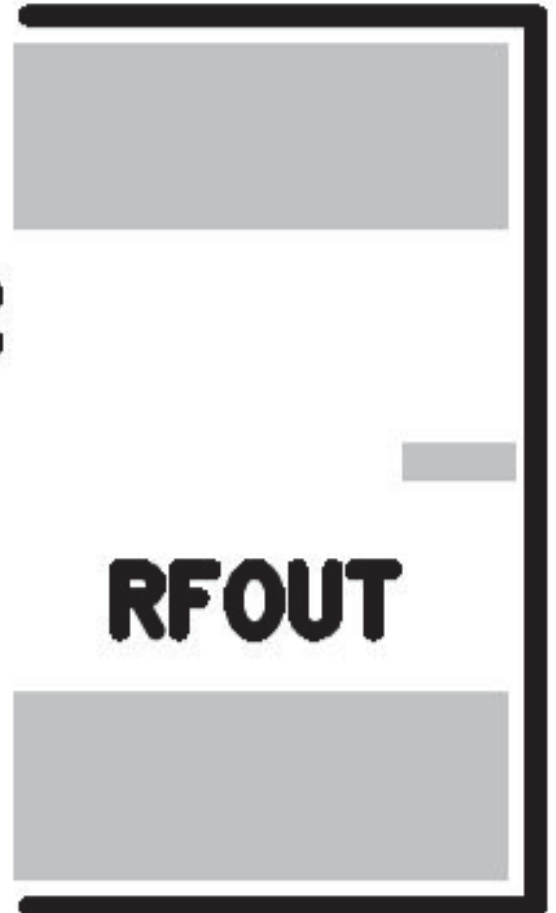

**RFOUT**

Component Replacement Guide—Component Side

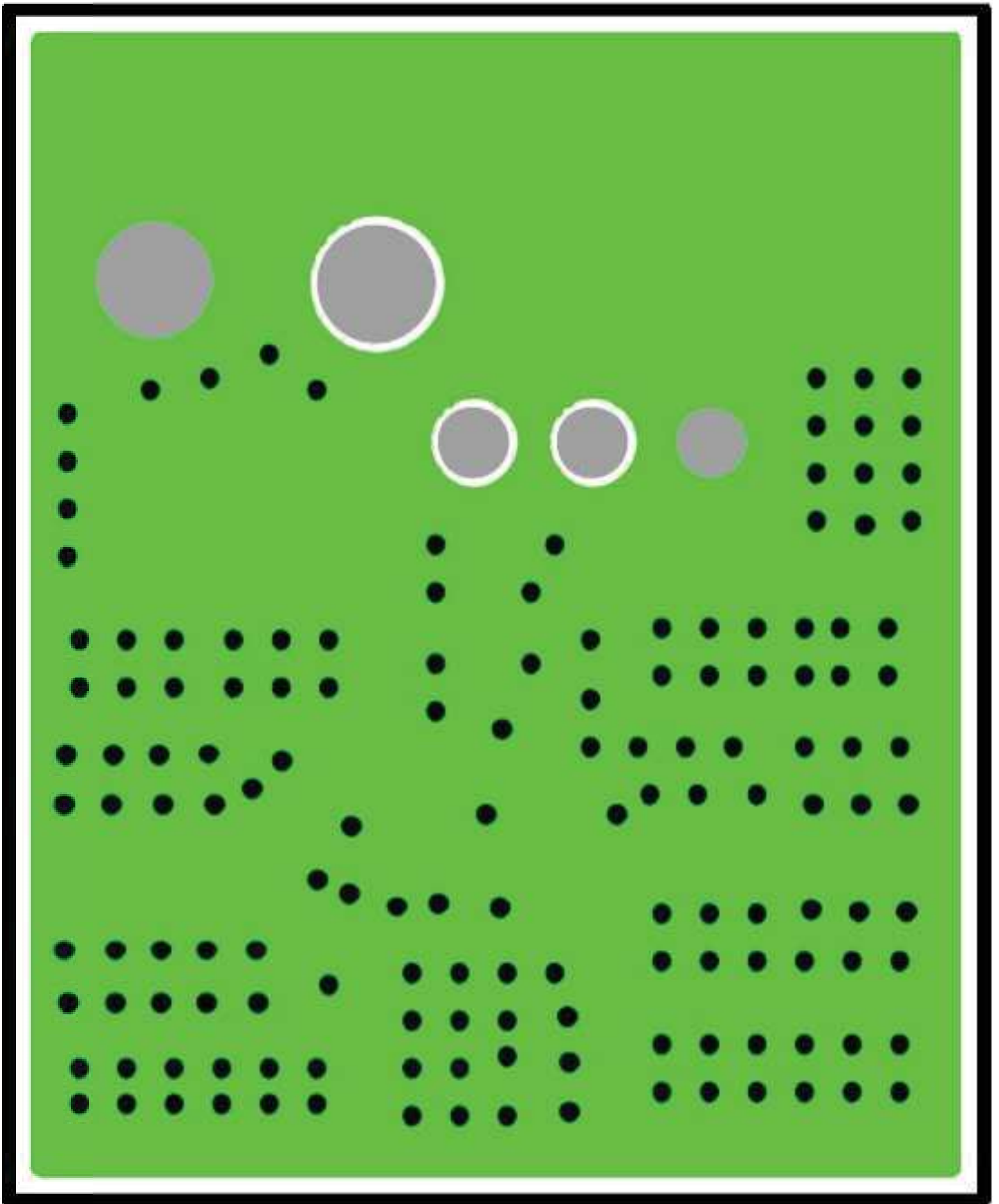

PCB Layout—Layer 2

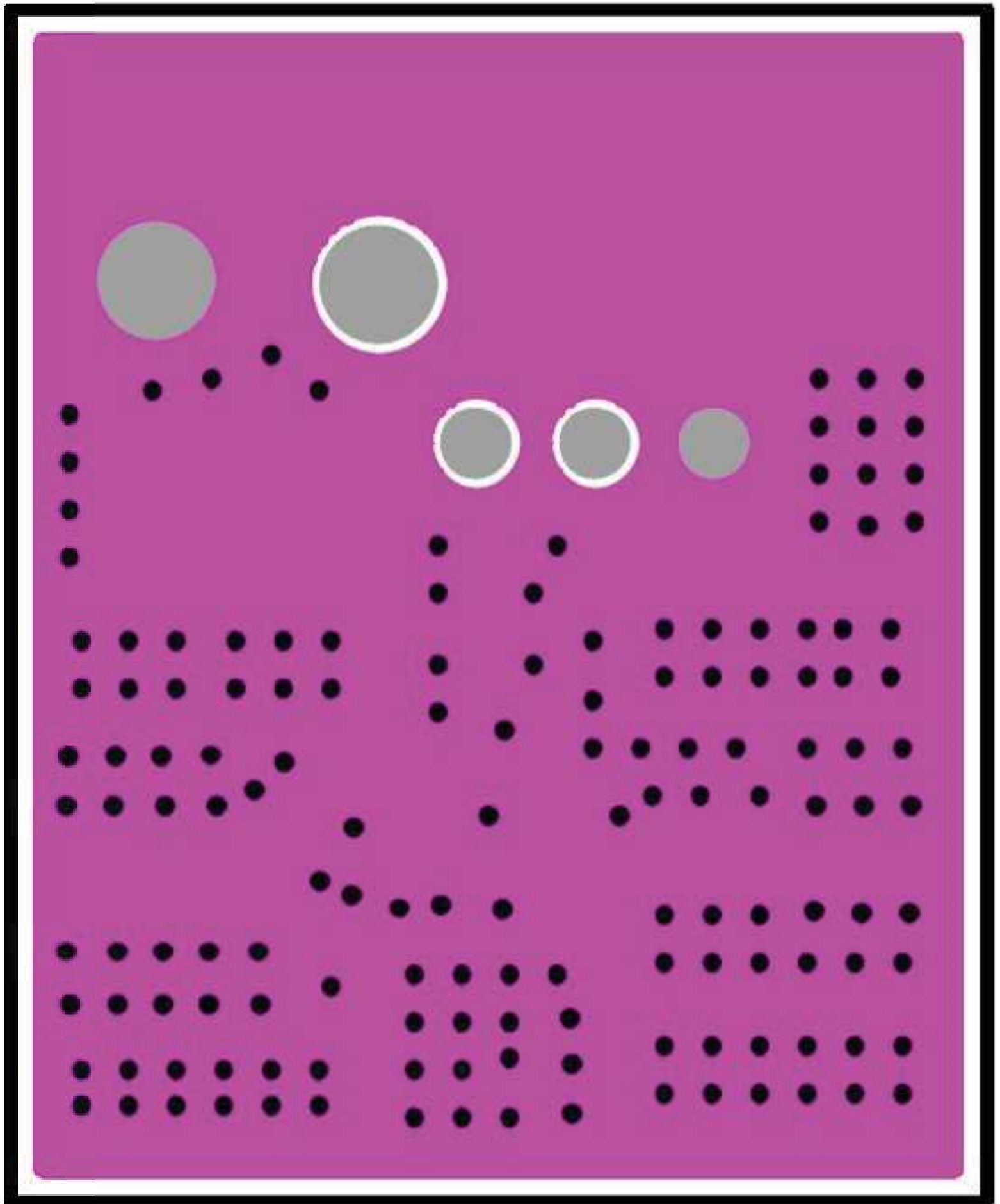

PCB Layout—Layer 3



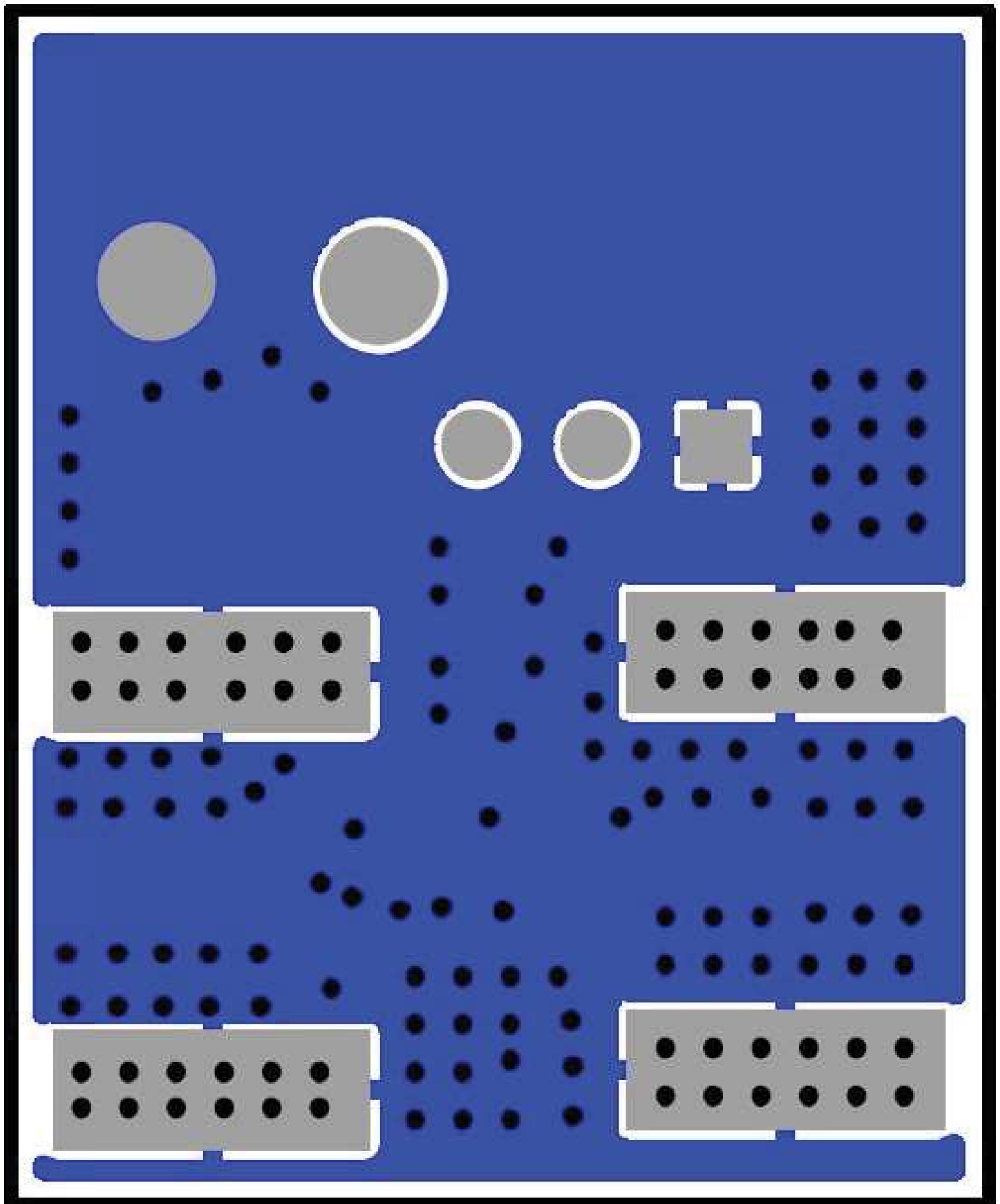

PCB Layout—Component Side

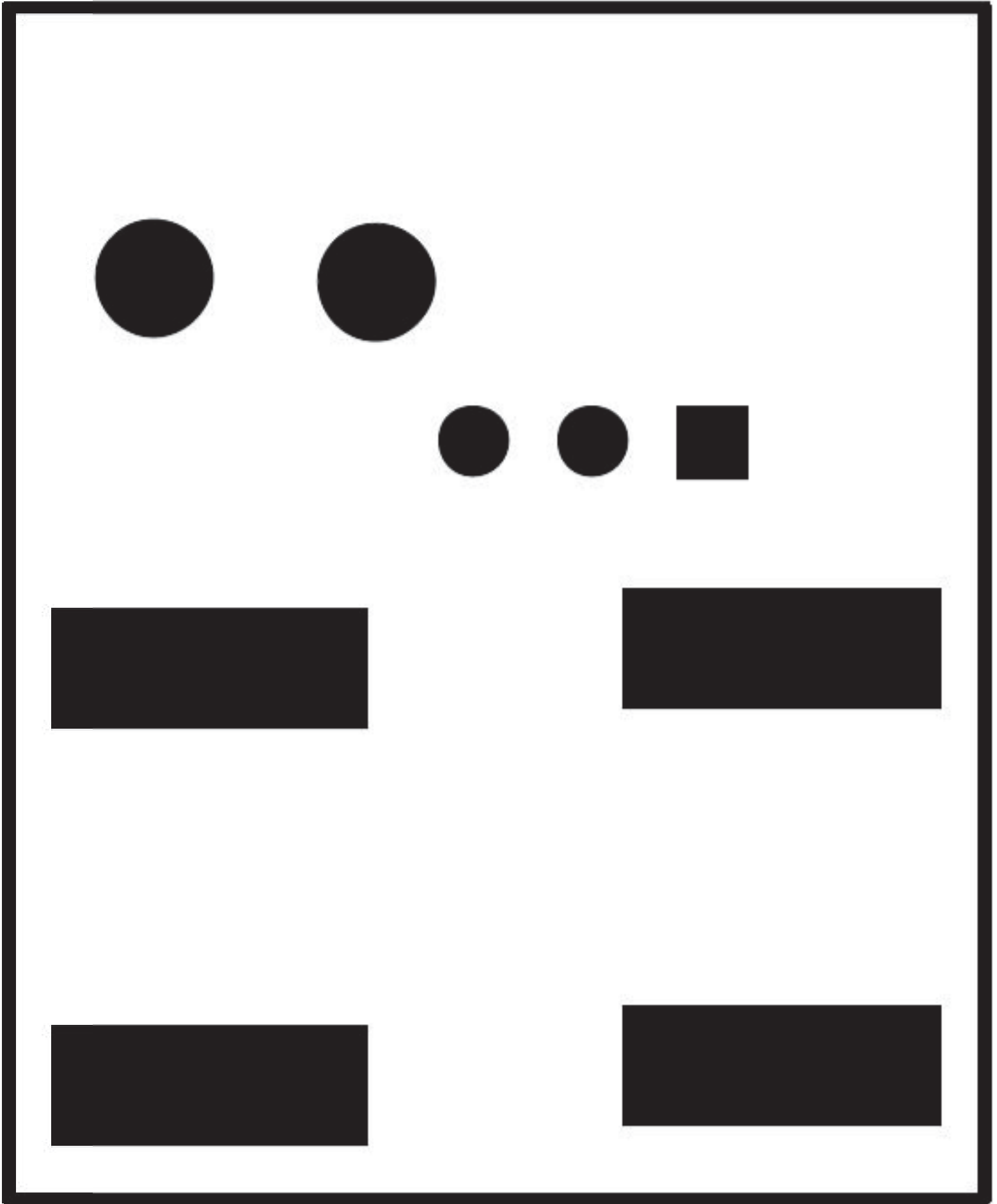

PCB Layout—Secondary Side

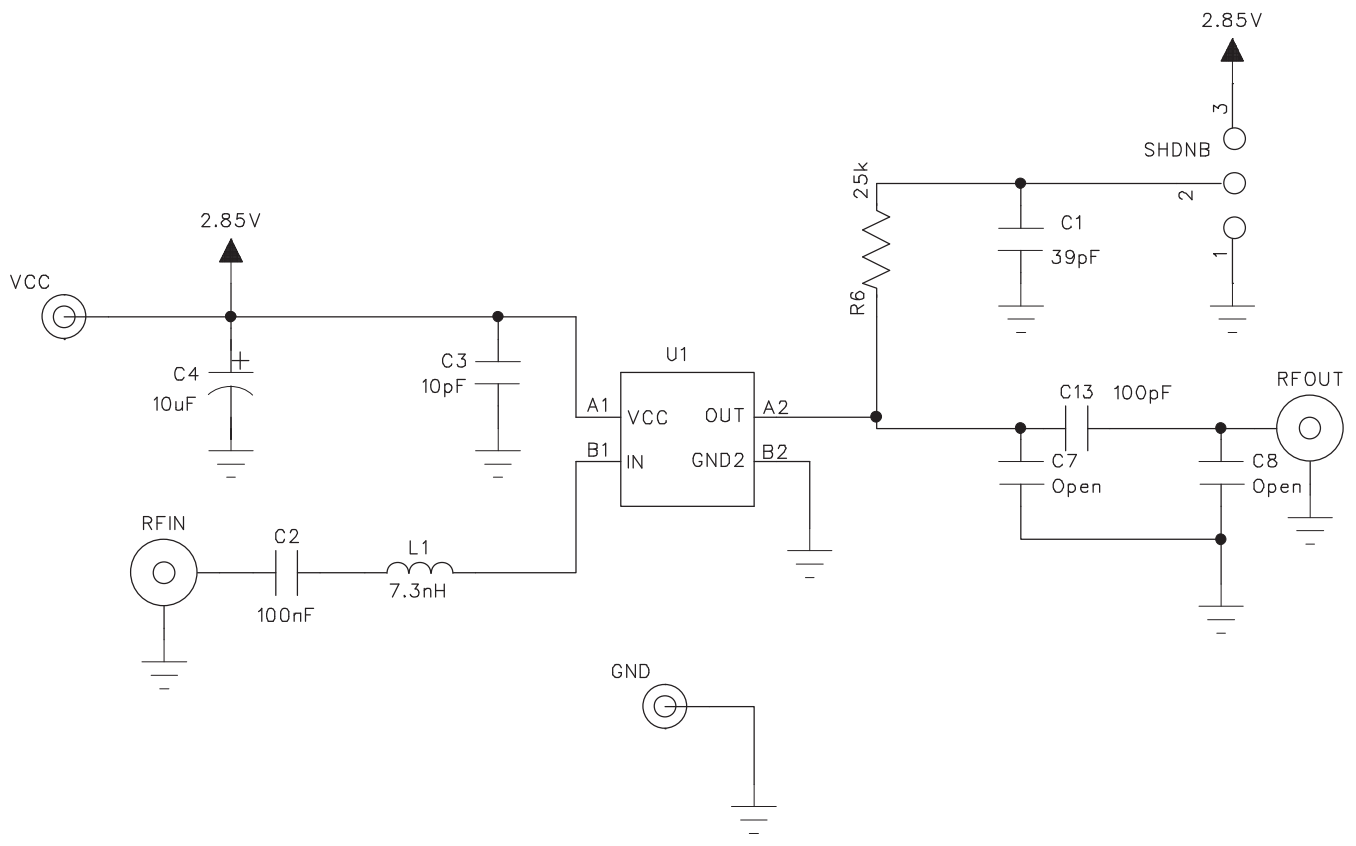

**MAX2686L EV Kit Schematic**

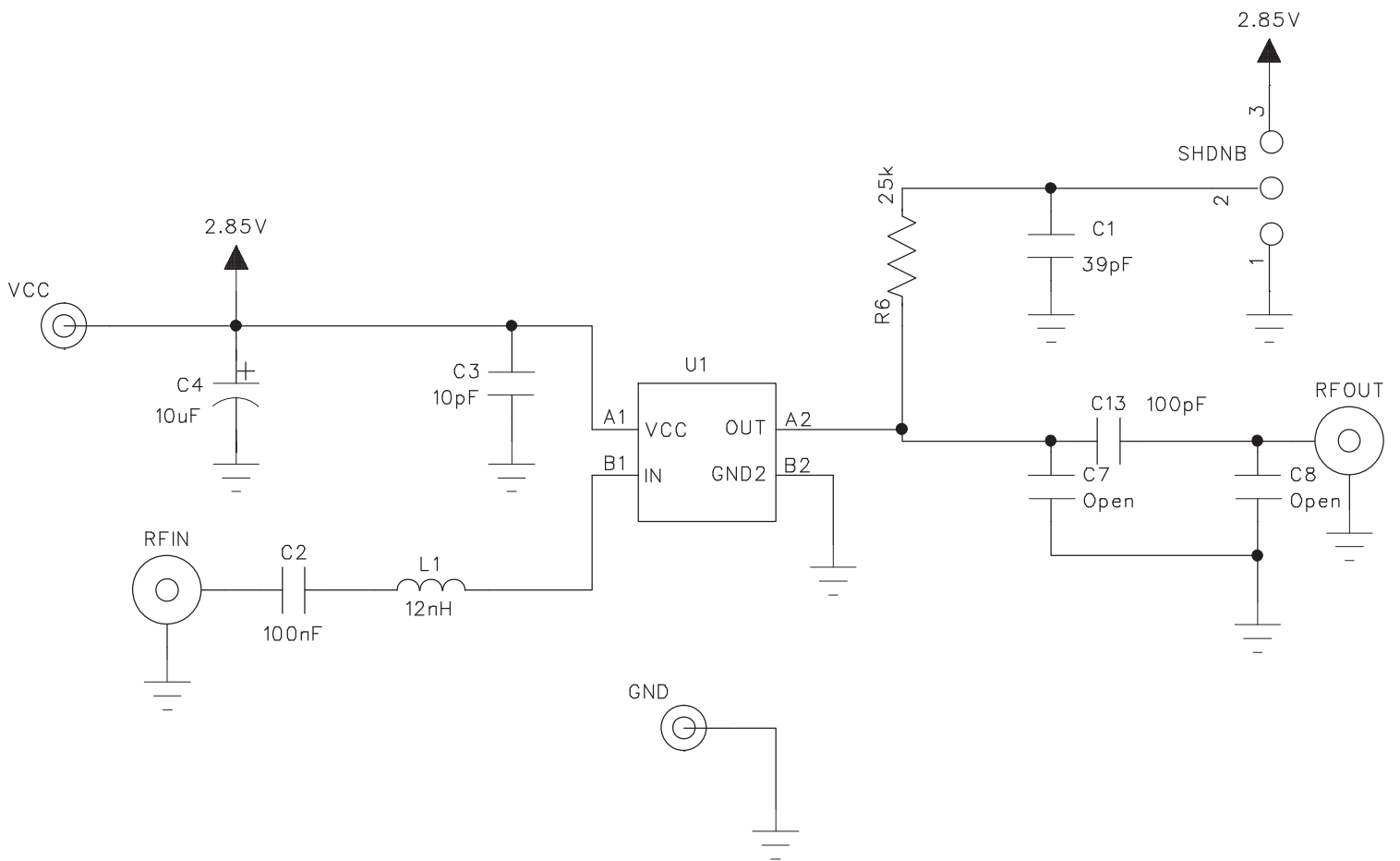

**MAX2693L EV Kit Schematic**