



Chipsmall Limited consists of a professional team with an average of over 10 year of expertise in the distribution of electronic components. Based in Hongkong, we have already established firm and mutual-benefit business relationships with customers from,Europe,America and south Asia,supplying obsolete and hard-to-find components to meet their specific needs.

With the principle of “Quality Parts,Customers Priority,Honest Operation,and Considerate Service”,our business mainly focus on the distribution of electronic components. Line cards we deal with include Microchip,ALPS,ROHM,Xilinx,Pulse,ON,Everlight and Freescale. Main products comprise IC,Modules,Potentiometer,IC Socket,Relay,Connector.Our parts cover such applications as commercial,industrial, and automotives areas.

We are looking forward to setting up business relationship with you and hope to provide you with the best service and solution. Let us make a better world for our industry!



Contact us

Tel: +86-755-8981 8866 Fax: +86-755-8427 6832

Email & Skype: info@chipsmall.com Web: www.chipsmall.com

Address: A1208, Overseas Decoration Building, #122 Zhenhua RD., Futian, Shenzhen, China



SPI/I²C UART with 128-Word FIFOs in WLP

General Description

The MAX3108A small form factor universal asynchronous receiver-transmitter (UART) with 128 words each of receive and transmit FIFOs is controlled through a serial I²C or SPI controller interface. Auto-sleep and shutdown modes help reduce power consumption during periods of inactivity. A low 500µA (max) supply current, 1µA shutdown current, and tiny 25-bump WLP (2.1mm x 2.1mm) package make the device ideal for low-power portable devices. The device operates from a 1.71V to 3.6V supply voltage.

Baud rates up to 24Mbps make the MAX3108A suitable for today's high data rate applications. A phase-locked loop (PLL), predivider, and fractional baud-rate generator allow high-resolution baud-rate programming and minimize the dependency of baud rate on reference clock frequency.

Four GPIOs can be used as inputs, outputs, or interrupt inputs. When configured as outputs, they can be programmed to be open-drain outputs and sink up to 20mA of current.

The device is ideal for portable and handheld devices, is available in a 25-bump (2.1mm x 2.1mm) 0.4mm pitch WLP package, and is specified over the -40°C to +85°C extended temperature range.

Applications

Portable Communication Devices
 Mobile Internet Devices
 Low-Power Handheld Devices
 Medical Systems
 Point-of-Sale Systems

Features

- ◆ 24Mbps (max) Baud Rate
- ◆ 1µA Shutdown Current
- ◆ 1.71V to 3.6V Supply Range
- ◆ High-Resolution Programmable Baud Rate
- ◆ SPI Up to 26MHz Clock Rate
- ◆ Fast Mode Plus I²C Up to 1MHz
- ◆ Automatic RTS and CTS Hardware Flow Control
- ◆ Automatic XON/XOFF Software Flow Control
- ◆ Special-Character Detection
- ◆ 9-Bit Multidrop Mode Data Filtering
- ◆ SIR- and MIR-Compliant IrDASM Encoder/Decoder
- ◆ Flexible Logic Levels on the Controller and Transceiver Interfaces
- ◆ Four Flexible GPIOs
- ◆ Line Noise Indication
- ◆ Shutdown and Auto-Sleep Modes
- ◆ Integrated PLL and Divider
- ◆ Register Compatible with the MAX3107, MAX3109, and MAX14830
- ◆ 25-Bump WLP Package (2.1mm x 2.1mm)

Ordering Information

PART	TEMP RANGE	PIN-PACKAGE
MAX3108AWEA+T	-40°C to +85°C	25 WLP

+Denotes a lead(Pb)-free/RoHS-compliant package.

IrDA is a service mark of Infrared Data Association Corporation.

Functional Diagram

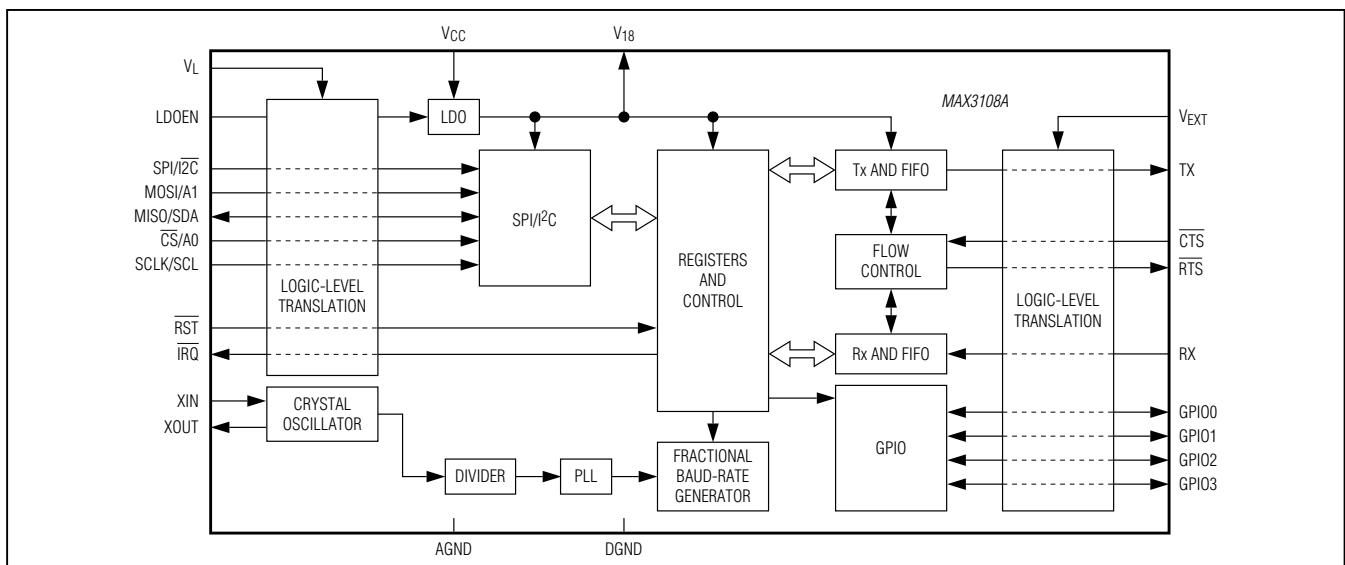

For pricing, delivery, and ordering information, please contact Maxim Direct at 1-888-629-4642, or visit Maxim's website at www.maximintegrated.com.

MAX3108A

SPI/I²C UART with 128-Word FIFOs in WLP

TABLE OF CONTENTS

Absolute Maximum Ratings	6
Package Thermal Characteristics	6
DC Electrical Characteristics	6
AC Electrical Characteristics	9
Timing Diagrams	11
Typical Operating Characteristics	12
Bump Configuration	13
Bump Description	13
Detailed Description	15
Register Set	15
Receive and Transmit FIFOs	15
Transmitter Operation	15
Receiver Operation	16
Line Noise Indication	17
Clock Selection	18
Crystal Oscillator	18
External Clock Source	18
PLL and Predivider	18
Fractional Baud-Rate Generator	18
2x and 4x Rate Modes	19
Multidrop Mode	19
Auto Data Filtering in Multidrop Mode	19
Auto Transceiver Direction Control	20
Echo Suppression	21
Auto Hardware Flow Control	22
AutoRTS Control	22
AutoCTS Control	22
Auto Software (XON/XOFF) Flow Control	22
Receiver Flow Control	22
Transmitter Flow Control	23
FIFO Interrupt Triggering	23
Low-Power Standby Modes	23
Forced-Sleep Mode	23
Auto-Sleep Mode	23
Shutdown Mode	23
Power-Up and $\overline{\text{IRQ}}$	23
Interrupt Structure	24

SPI/I²C UART with 128-Word FIFOs in WLP

TABLE OF CONTENTS (continued)

Interrupt Enabling	24
Interrupt Clearing	24
Register Map	25
Detailed Register Descriptions	26
Serial Controller Interface	48
SPI Interface	48
SPI Single-Cycle Access	48
SPI Burst Access	48
I ² C Interface	49
START, STOP, and Repeated START Conditions	49
Slave Address	49
Bit Transfer	49
Single-Byte Write	50
Burst Write	50
Single-Byte Read	51
Burst Read	51
Acknowledge Bits	52
Applications Information	52
Startup and Initialization	52
Low-Power Operation	53
Interrupts and Polling	53
Logic-Level Translation	53
Power-Supply Sequencing	54
Connector Sharing	54
RS-232 5x3 Application	54
Typical Application Circuit	55
Chip Information	55
Package Information	55
Revision History	56

MAX3108A

SPI/I²C UART with 128-Word FIFOs in WLP

LIST OF FIGURES

Figure 1. I ² C Timing Diagram	11
Figure 2. SPI Timing Diagram	11
Figure 3. Transmit FIFO Signals	15
Figure 4. Receive Data Format.	16
Figure 5. Receive FIFO	16
Figure 6. Midbit Sampling	17
Figure 7. Clock Selection Diagram	17
Figure 8. 2x and 4x Baud Rates.	19
Figure 9. Auto Transceiver Direction Control	20
Figure 10. Setup and Hold times in Auto Transceiver Direction Control	20
Figure 11. Half-Duplex with Echo Suppression	21
Figure 12. Echo Suppression Timing	21
Figure 13. Simplified Interrupt Structure.	24
Figure 14. PLL Signal Path	45
Figure 15. Single-Cycle Read	48
Figure 16. Single-Cycle Write.	48
Figure 17. I ² C START, STOP, and Repeated START Conditions	49
Figure 18. Write Byte Sequence.	50
Figure 19. Burst Write Sequence	50
Figure 20. Read Byte Sequence	51
Figure 21. Burst Read Sequence	51
Figure 22. Acknowledge	52
Figure 23. Startup and Initialization Flowchart	52
Figure 24. Logic-Level Translation	53
Figure 25. Connector Sharing with a USB Transceiver	54
Figure 26. RS-232 Application	54
Figure 27. RS-485 Half-Duplex Application	55

LIST OF TABLES

Table 1. StopBits Truth Table	37
Table 2. Lengthx Truth Table	37
Table 3. SwFlow[3:0] Truth Table	42
Table 4. PLLFactorx Selection Guide.	45
Table 5. I ² C Address Map	49

SPI/I²C UART with 128-Word FIFOs in WLP

LIST OF REGISTERS

Receive Hold Register (RHR)	26
Transmit Hold Register (THR)	26
IRQ Enable Register (IRQEn)	27
Interrupt Status Register (ISR)	28
Line Status Interrupt Enable Register (LSRIIntEn)	29
Line Status Register (LSR)	30
Special Character Interrupt Enable Register (SpclChrIntEn)	31
Special Character Interrupt Register (SpclCharInt)	32
STS Interrupt Enable Register (STSIntEn)	33
Status Interrupt Register (STSInt)	34
MODE1 Register	35
MODE2 Register	36
Line Control Register (LCR)	37
Receiver Timeout Register (RxTimeOut)	38
HDplxDelay Register	38
IrDA Register	39
Flow Level Register (FlowLvl)	39
FIFO Interrupt Trigger Level Register (FIFOTrgLvl)	40
Transmit FIFO Level Register (TxFIFOLvl)	40
Receive FIFO Level Register (RxFIFOLvl)	40
Flow Control Register (FlowCtrl)	41
XON1 Register	42
XON2 Register	43
XOFF1 Register	43
XOFF2 Register	44
GPIO Configuration Register (GPIOConf)	44
GPIO Data Register (GPIOData)	45
PLL Configuration Register (PLLConfig)	45
Baud-Rate Generator Configuration Register (BRGConfig)	46
Baud-Rate Generator LSB Divisor Register (DIVLSB)	46
Baud-Rate Generator MSB Divisor Register (DIVMSB)	47
Clock Source Register (CLKSource)	47

MAX3108A

SPI/I²C UART with 128-Word FIFOs in WLP

ABSOLUTE MAXIMUM RATINGS

(Voltages referenced to AGND.)

V _L , V _{CC} , V _{EXT} , XIN	-0.3V to +4.0V
XOUT	-0.3V to (V _{CC} + 0.3V)
V ₁₈	-0.3V to the lesser of (V _{CC} + 0.3V) and 2.0V
R _{ST} , I _{RQ} , MOSI/A1, CS/A0, SCLK/SCL, MISO/SDA, LDOEN, SPI/I ² C	-0.3V to (V _L + 0.3V)
TX, RX, R _{TS} , C _{TS} , GPIO_	-0.3V to (V _{EXT} + 0.3V)

DGND	-0.3V to +0.3V
Continuous Power Dissipation (T _A = +70°C)	
WLP (derate 19.2mW/°C above +70°C)	1536mW
Operating Temperature Range	-40°C to +85°C
Maximum Junction Temperature	+150°C
Storage Temperature Range	-65°C to +150°C
Soldering Temperature (reflow)	+260°C

PACKAGE THERMAL CHARACTERISTICS (Note 1)

WLP

Junction-to-Ambient Thermal Resistance (θ_{JA}).....52°C/W

Junction-to-Case Thermal Resistance (θ_{JC}).....11°C/W

Note 1: Package thermal resistances were obtained using the method described in JEDEC specification JESD51-7, using a four-layer board. For detailed information on package thermal considerations, refer to www.maximintegrated.com/thermal-tutorial.

Stresses beyond those listed under "Absolute Maximum Ratings" may cause permanent damage to the device. These are stress ratings only, and functional operation of the device at these or any other conditions beyond those indicated in the operational sections of the specifications is not implied. Exposure to absolute maximum rating conditions for extended periods may affect device reliability.

DC ELECTRICAL CHARACTERISTICS

(V_{CC} = 1.71V to 3.6V, V_L = 1.71V to 3.6V, V_{EXT} = 1.71V to 3.6V, T_A = -40°C to +85°C, unless otherwise noted. Typical values are at V_{CC} = 2.8V, V_L = 1.8V, V_{EXT} = 2.5V, T_A = +25°C.) (Notes 2, 3)

PARAMETER	SYMBOL	CONDITIONS	MIN	TYP	MAX	UNITS
Digital Interface Supply Voltage	V _L		1.71		3.6	V
Analog Supply Voltage	V _{CC}	Internal PLL disabled and bypassed	1.71		3.6	V
		Internal PLL enabled	2.35		3.6	
UART Interface Logic Supply Voltage	V _{EXT}		1.71		3.6	V
Logic Supply Voltage	V ₁₈		1.65		1.95	V
CURRENT CONSUMPTION						
V _{CC} Supply Current	I _{CC}	1.8MHz crystal oscillator active, PLL disabled, SPI/I ² C interface idle, UART interfaces idle, LDOEN = high			500	μA
		Baud rate = 1Mbps, 20MHz external clock, SPI/I ² C interface idle, PLL disabled, UART in loopback mode, LDOEN = low			500	
V _{CC} + V _L + V _A Shutdown Supply Current	I _{SHDN}	R _{ST} = low, MISO, SCLK, MOSI, SPI/I ² C, CS = low; LDOEN = low/high, C _{TS} = low/high, RX = high.		0	1	μA
V ₁₈ Input Power-Supply Current in Shutdown Mode	I _{18SHDN}	Shutdown mode, LDOEN = low, R _{ST} = low, all inputs and outputs are idle			50	μA

MAX3108A

SPI/I²C UART with 128-Word FIFOs in WLP

DC ELECTRICAL CHARACTERISTICS (continued)

(V_{CC} = 1.71V to 3.6V, V_L = 1.71V to 3.6V, V_{EXT} = 1.71V to 3.6V, T_A = -40°C to +85°C, unless otherwise noted. Typical values are at V_{CC} = 2.8V, V_L = 1.8V, V_{EXT} = 2.5V, T_A = +25°C.) (Notes 2, 3)

PARAMETER	SYMBOL	CONDITIONS	MIN	TYP	MAX	UNITS
V ₁₈ Input Power-Supply Current	I ₁₈	Baud rate = 1Mbps, 20MHz external clock, PLL disabled, UART in loopback mode, LDOEN = low (Note 4)			2	mA
SCLK/SCL, MISO/SDA						
MISO/SDA Output Logic-Low Voltage in I ² C Mode	V _{OLI2C}	Sink current = 3mA, V _L > 2V			0.4	V
		Sink current = 3mA, V _L < 2V			0.2 x V _L	
MISO/SDA Output Logic-Low Voltage in SPI Mode	V _{OLSPI}	Sink current = 2mA			0.4	V
MISO/SDA Output Logic-High Voltage in SPI Mode	V _{OHSPI}	Source current = 2mA	V _L - 0.4			V
Input Logic-Low Voltage	V _{IL}	SPI and I ² C mode			0.3 x V _L	V
Input Logic-High Voltage	V _{IH}	SPI and I ² C mode	0.7 x V _L			V
Input Hysteresis	V _{HYST}	SPI and I ² C mode		0.05 x V _L		V
Input Leakage Current	I _{IL}	V _{IN} = 0 to V _L , SPI and I ² C mode	-1		+1	μA
Input Capacitance	C _{IN}	SPI and I ² C mode		5		pF
SPI/I²C, CS/A0, MOSI/A1 INPUTS						
Input Logic-Low Voltage	V _{IL}	SPI and I ² C mode			0.3 x V _L	V
Input Logic-High Voltage	V _{IH}	SPI and I ² C mode	0.7 x V _L			V
Input Hysteresis	V _{HYST}	SPI and I ² C mode		50		mV
Input Leakage Current	I _{IL}	V _{IN} = 0 to V _L , SPI and I ² C mode	-1		+1	μA
Input Capacitance	C _{IN}	SPI and I ² C mode		5		pF
IRQ OUTPUT (OPEN DRAIN)						
Output Logic-Low Voltage	V _{OL}	Sink current = 2mA			0.4	V
Output Leakage Current	I _{OL}	V _{IRQ} = 0 to V _L , $\overline{\text{IRQ}}$ is not asserted	-1		+1	μA
LDOEN AND RST INPUTS						
Input Logic-Low Voltage	V _{IL}				0.3 x V _L	V
Input Logic-High Voltage	V _{IH}		0.7 x V _L			V
Input Hysteresis	V _{HYST}			50		mV
Input Leakage Current	I _{IL}	V _{IN} = 0 to V _L	-1		+1	μA

MAX3108A

SPI/I²C UART with 128-Word FIFOs in WLP

DC ELECTRICAL CHARACTERISTICS (continued)

(V_{CC} = 1.71V to 3.6V, V_L = 1.71V to 3.6V, V_{EXT} = 1.71V to 3.6V, T_A = -40°C to +85°C, unless otherwise noted. Typical values are at V_{CC} = 2.8V, V_L = 1.8V, V_{EXT} = 2.5V, T_A = +25°C.) (Notes 2, 3)

PARAMETER	SYMBOL	CONDITIONS	MIN	TYP	MAX	UNITS
UART INTERFACE						
RTS, TX OUTPUTS						
Output Logic-Low Voltage	V _{OL}	Sink current = 2mA			0.4	V
Output Logic-High Voltage	V _{OH}	Source current = 2mA	0.7 × V _{EXT}			V
Input Leakage Current	I _{IL}	Output is three-stated, V _{RTS} = 0 to V _{EXT}	-1		+1	μA
Input Capacitance	C _{IN}	High-impedance mode		5		pF
CTS, RX INPUTS						
Input Logic-Low Voltage	V _{IL}				0.3 × V _{EXT}	V
Input Logic-High Voltage	V _{IH}		0.7 × V _{EXT}			V
Input Hysteresis	V _{HYST}			50		mV
CTS Input Leakage Current	I _{IL}	V _{CTS} = 0 to V _{EXT}	-1		+1	μA
RX Pullup Current	I _{PU}	V _{RX} = 0V, V _{EXT} = 3.6V	-7.5	-5.5	-3.5	μA
Input Capacitance	C _{IN}			5		pF
GPIO_ INPUTS/OUTPUTS						
Output Logic-Low Voltage	V _{OL}	Sink current = 20mA, push-pull or open-drain output type, V _{EXT} > 2.3V			0.45	V
		Sink current = 20mA, push-pull or open-drain output type, V _{EXT} < 2.3V			0.55	
Output Logic-High Voltage	V _{OH}	Source current = 5mA, push-pull output type	V _{EXT} - 0.4V			V
Input Logic-Low Voltage	V _{IL}	GPIO_ is configured as an input			0.4	V
Input Logic-High Voltage	V _{IH}	GPIO_ is configured as an input	2/3 × V _{EXT}			V
Pulldown Current	I _{PD}	V _{GPIO_} = V _{EXT} = 3.6V, GPIO_ is configured as an input	3.5	5.5	7.5	μA
XIN						
Input Logic-Low Voltage	V _{IL}				0.6	V
Input Logic-High Voltage	V _{IH}		1.2			V
Input Capacitance	C _{XIN}			16		pF
XOUT						
Input Capacitance	C _{XOUT}			16		pF

SPI/I²C UART with 128-Word FIFOs in WLP

AC ELECTRICAL CHARACTERISTICS

(V_{CC} = 1.71V to 3.6V, V_L = 1.71V to 3.6V, V_{EXT} = 1.71V to 3.6V, T_A = -40°C to +85°C, unless otherwise noted. Typical values are at V_{CC} = 2.8V, V_L = 1.8V, V_{EXT} = 2.5V, T_A = +25°C.) (Note 2)

PARAMETER	SYMBOL	CONDITIONS	MIN	TYP	MAX	UNITS
External Crystal Frequency	f _{XOSC}		1		4	MHz
External Clock Frequency	f _{CLK}		0.5		35	MHz
External Clock Duty Cycle		(Note 5)	45		55	%
Baud-Rate Generator Clock Input Frequency	f _{REF}				96	MHz
I²C BUS: TIMING CHARACTERISTICS (Figure 1)						
SCL Clock Frequency	f _{SCL}	Standard mode			100	kHz
		Fast mode			400	
		Fast mode plus			1000	
Bus Free Time Between a STOP and START Condition	t _{BUF}	Standard mode	4.7			μs
		Fast mode	1.3			
		Fast mode plus	0.5			
Hold Time for START Condition and Repeated START Condition	t _{HD:STA}	Standard mode	4.0			μs
		Fast mode	0.6			
		Fast mode plus	0.26			
Low Period of the SCL Clock	t _{LOW}	Standard mode	4.7			μs
		Fast mode	1.3			
		Fast mode plus	0.5			
High Period of the SCL Clock	t _{HIGH}	Standard mode	4.0			μs
		Fast mode	0.6			
		Fast mode plus	0.26			
Data Hold Time	t _{HD:DAT}	Standard mode	0		0.9	μs
		Fast mode	0		0.9	
		Fast mode plus	0			
Data Setup Time	t _{SU:DAT}	Standard mode	250			ns
		Fast mode	100			
		Fast mode plus	50			
Setup Time for Repeated START Condition	t _{SU:STA}	Standard mode	4.7			μs
		Fast mode	0.2			
		Fast mode plus	0.26			
Rise Time of Incoming SDA and SCL Signals	t _R	Standard mode (0.3 × V _L to 0.7 × V _L) (Note 6)	20 + 0.1C _B		1000	ns
		Fast mode (0.3 × V _L to 0.7 × V _L) (Note 6)	20 + 0.1C _B		300	
		Fast mode plus			120	
Fall Time of SDA and SCL Signals	t _F	Standard mode (0.3 × V _L to 0.7 × V _L) (Note 6)	20 + 0.1C _B		1000	ns
		Fast mode (0.3 × V _L to 0.7 × V _L) (Note 6)	20 + 0.1C _B		300	
		Fast mode plus			120	

MAX3108A

SPI/I²C UART with 128-Word FIFOs in WLP

AC ELECTRICAL CHARACTERISTICS (continued)

(V_{CC} = 1.71V to 3.6V, V_L = 1.71V to 3.6V, V_{EXT} = 1.71V to 3.6V, T_A = -40°C to +85°C, unless otherwise noted. Typical values are at V_{CC} = 2.8V, V_L = 1.8V, V_{EXT} = 2.5V, T_A = +25°C.) (Note 2)

PARAMETER	SYMBOL	CONDITIONS	MIN	TYP	MAX	UNITS
Setup Time for STOP Condition	t _{SU:STO}	Standard mode	4.7			μs
		Fast mode	0.6			
		Fast mode plus	0.26			
Capacitive Load for SDA and SCL	C _B	Standard mode (Note 5)			400	pF
		Fast mode (Note 5)			400	
		Fast mode plus (Note 5)			550	
SCL and SDA I/O Capacitance	C _{I/O}	(Note 5)			10	pF
Pulse Width of Spike Suppressed	t _{SP}				50	ns
SPI BUS: TIMING CHARACTERISTICS (Figure 2)						
SCLK Clock Period	t _{CH+tCL}		38.4			ns
SCLK Pulse-Width High	t _{CH}		16			ns
SCLK Pulse-Width Low	t _{CL}		16			ns
$\overline{\text{CS}}$ Fall to SCLK Rise Time	t _{CSS}		0			ns
MOSI Hold Time	t _{DH}		3			ns
MOSI Setup Time	t _{DS}		5			ns
Output Data Propagation Delay	t _{DO}				20	ns
MISO Rise and Fall Times	t _{FT}				10	ns
$\overline{\text{CS}}$ Hold Time	t _{CSH}		30			ns

Note 2: All units are production tested at T_A = +25°C. Specifications over temperature are guaranteed by design.

Note 3: Currents entering the IC are positive and currents exiting the IC are negative.

Note 4: When V₁₈ is powered by an external voltage supply, it must have current capability above or equal to I₁₈.

Note 5: Guaranteed by design; not production tested.

Note 6: C_B is the total capacitance of either the clock or data line of the synchronous bus in pF.

SPI/I²C UART with 128-Word FIFOs in WLP

Timing Diagrams

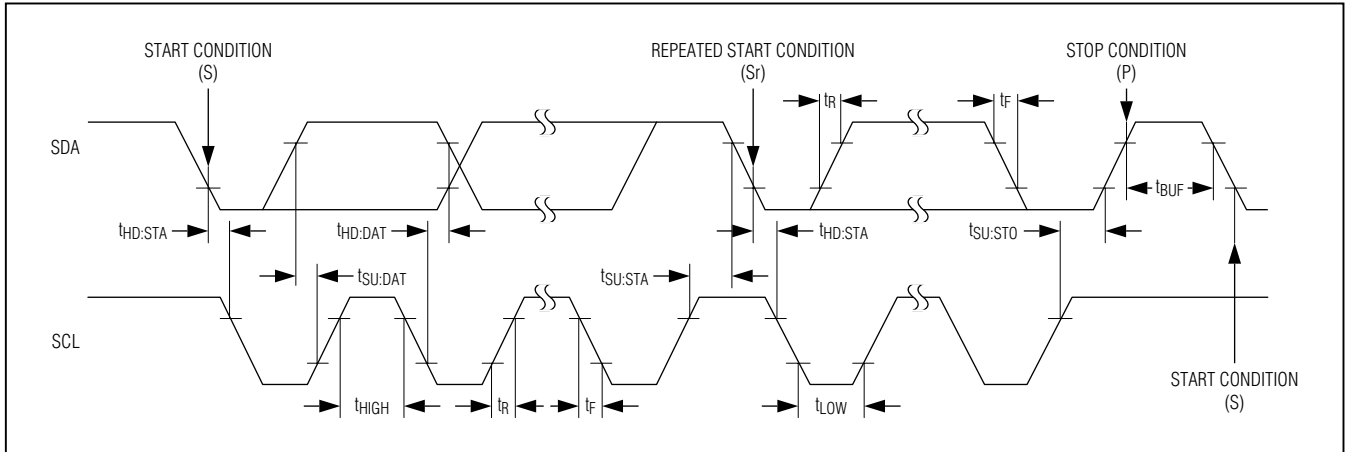

Figure 1. I²C Timing Diagram

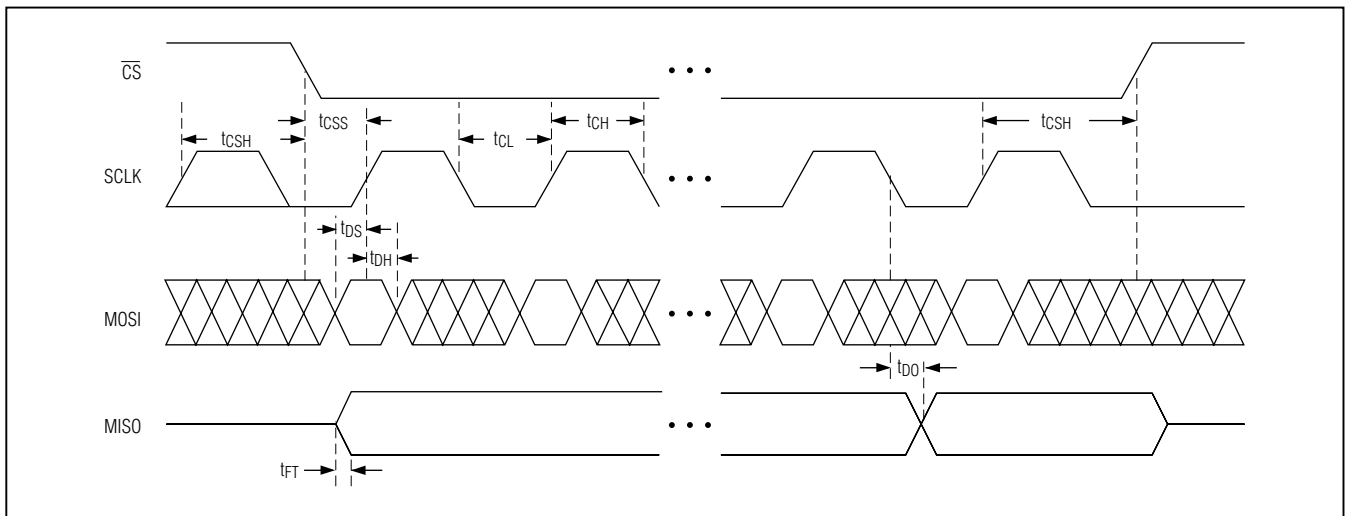

Figure 2. SPI Timing Diagram

MAX3108A

SPI/I²C UART with 128-Word FIFOs in WLP

Typical Operating Characteristics

(V_{CC} = 2.5V, V_L = 2.5V, V_{EXT} = 2.5V, V_{LDOEN} = V_L, T_A = +25°C, unless otherwise noted.)

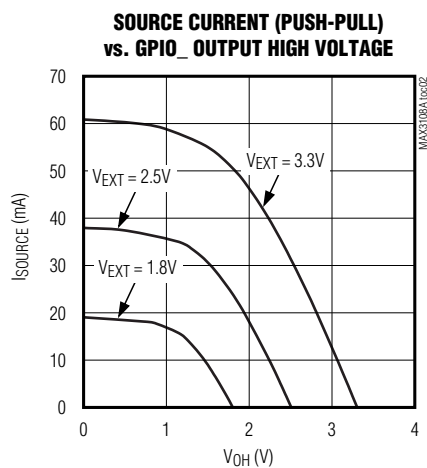
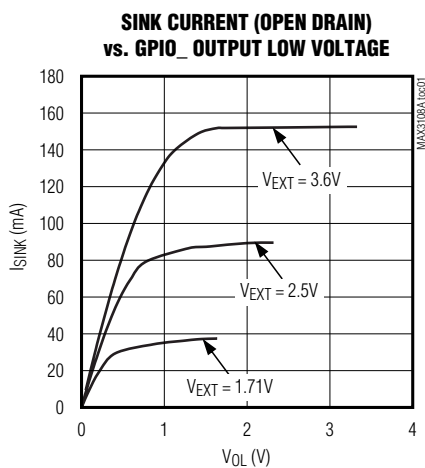

MAX3108A

SPI/I²C UART with 128-Word FIFOs in WLP

Bump Configuration

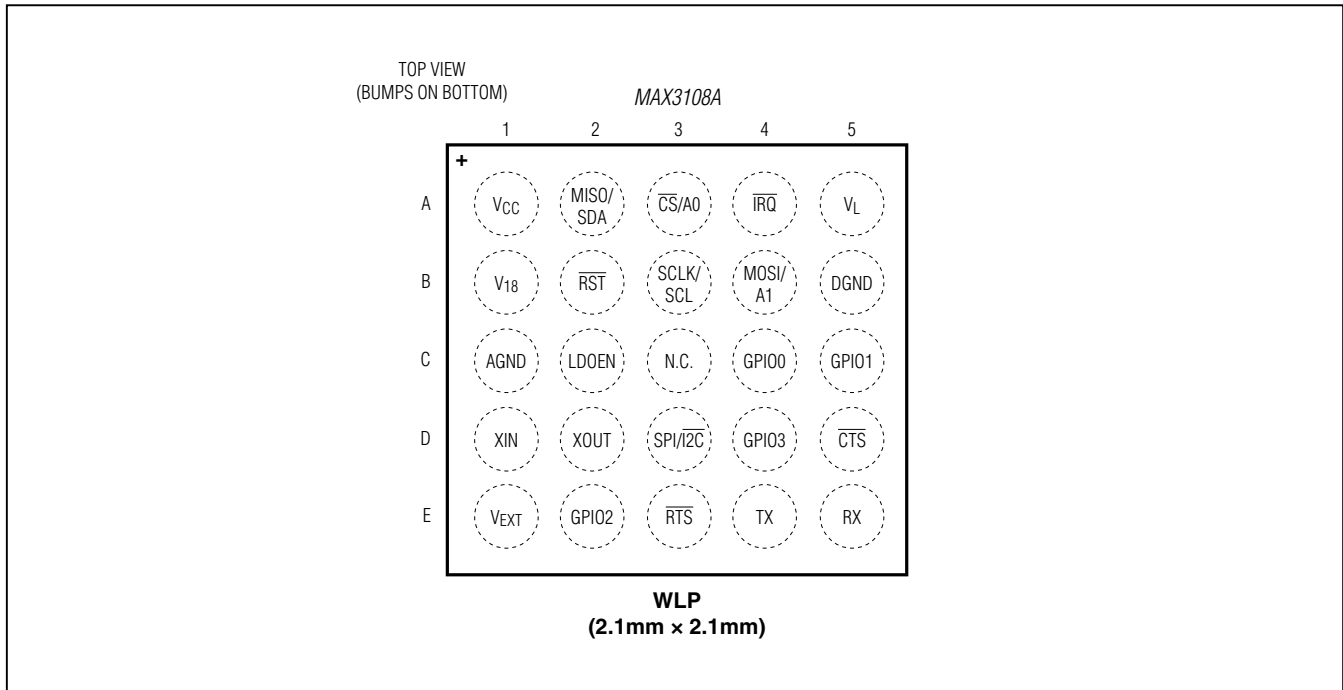

Bump Description

BUMP	NAME	FUNCTION
A1	V _{CC}	Analog Power Supply. V _{CC} powers the PLL and internal LDO. Bypass V _{CC} with a 0.1μF ceramic capacitor to AGND.
A2	MISO/SDA	Serial-Data Output. When SPI/I ² C is high, MISO/SDA functions as the SPI master-input, slave-output (MISO). When SPI/I ² C is low, MISO/SDA functions as the SDA, I ² C serial-data input/output. MISO/SDA is high impedance when \overline{RST} is driven low, or when the externally supplied 18V is powered off.
A3	$\overline{CS}/A0$	Active-Low Chip-Select and Address 0 Input. When SPI/I ² C is high, $\overline{CS}/A0$ functions as the \overline{CS} , SPI active-low chip-select. When SPI/I ² C is low, $\overline{CS}/A0$ functions as the A0 I ² C device address programming input. Connect $\overline{CS}/A0$ to DGND, V _L , SCL, or SDA when SPI/I ² C is low.
A4	\overline{IRQ}	Active-Low Interrupt Open-Drain Output. \overline{IRQ} is asserted when an interrupt is pending. \overline{IRQ} is high impedance when \overline{RST} is driven low.
A5	V _L	Digital Interface Power Supply. V _L powers the internal logic-level translators for \overline{RST} , \overline{IRQ} , MOSI/A1, $\overline{CS}/A0$, SCLK/SCL, MISO/SDA, LDOEN, and SPI/I ² C. Bypass V _L with a 0.1μF ceramic capacitor to DGND.
B1	V ₁₈	Internal 1.8V LDO Output and 1.8V Power-Supply Input. Bypass V ₁₈ with a 1μF ceramic capacitor to DGND.
B2	\overline{RST}	Active-Low Reset Input. Drive \overline{RST} low to force the UART into hardware reset mode. Driving \overline{RST} low also enables low-power shutdown mode. When \overline{RST} is low, the internal 18V LDO is switched off, even if LDOEN input is kept high.

MAX3108A

SPI/I²C UART with 128-Word FIFOs in WLP

Bump Description (continued)

BUMP	NAME	FUNCTION
B3	SCLK/SCL	Serial-Clock Input. When SPI/I ² C is high, SCLK/SCL functions as the SCLK SPI serial-clock input (up to 26MHz). When SPI/I ² C is low, SCLK/SCL functions as the SCL, I ² C serial-clock input (up to 1MHz in fast mode plus).
B4	MOSI/A1	Serial-Data Input and Address 1 Input. When SPI/I ² C is high, MOSI/A1 functions as the SPI master-output, slave-input (MOSI). When SPI/I ² C is low, MOSI/A1 functions as the A1 I ² C device address programming input. Connect MOSI/A1 to DGND, V _L , SCL, or SDA when SPI/I ² C is low.
B5	DGND	Digital Ground
C1	AGND	Analog Ground
C2	LDOEN	LDO Enable Input. Drive LDOEN high to enable the internal 1.8V LDO. Drive LDOEN low to disable the internal LDO. Supply V ₁₈ with an external voltage source when LDOEN is low.
C3	N.C.	Not Connected. Internally not connected.
C4	GPIO0	General-Purpose Input/Output 0. GPIO0 is user-programmable as an input or output (push-pull or open drain) or an external event-driven interrupt source. GPIO0 has a weak pulldown resistor to DGND when configured as an input.
C5	GPIO1	General-Purpose Input/Output 1. GPIO1 is user programmable as an input or output (push-pull or open drain) or an external event-driven interrupt source. GPIO1 has a weak pulldown resistor to DGND when configured as an input.
D1	XIN	Crystal/Clock Input. When using an external crystal, connect one end of the crystal to XIN and the other end to XOUT. When using an external clock source, drive XIN with the single-ended external clock.
D2	XOUT	Crystal Output. When using an external crystal, connect one end of the crystal to XOUT and the other end to XIN. When using an external clock source, leave XOUT unconnected.
D3	SPI/I ² C	SPI Selector Input or Active-Low I ² C. Drive SPI/I ² C low to enable I ² C. Drive SPI/I ² C high to enable SPI.
D4	GPIO3	General-Purpose Input/Output 3. GPIO3 is user-programmable as an input or output (push-pull or open drain) or an external event-driven interrupt source. GPIO3 has a weak pulldown resistor to DGND when configured as an input.
D5	CTS	Active-Low Clear-to-Send Input. CTS is a flow-control status input.
E1	V _{EXT}	Transceiver Interface Power Supply. V _{EXT} powers the internal logic-level translators for RX, TX, RTS, CTS, and GPIO_. Bypass V _{EXT} with a 0.1μF ceramic capacitor to DGND.
E2	GPIO2	General-Purpose Input/Output 2. GPIO2 is user programmable as an input or output (push-pull or open drain) or an external event-driven interrupt source. GPIO2 has a weak pulldown resistor to DGND when configured as an input.
E3	RTS	Active-Low Request-to-Send Output. RTS can be set high or low by programming the LCR register. RTS is logic-high when RST is low when the externally supplied 18V is not powered.
E4	TX	Serial Transmitting Data Output. TX is logic-high when RST is low or when the externally supplied 18V is not powered.
E5	RX	Serial Receiving Data Input. RX has an internal weak pullup resistor to V _{EXT} .

SPI/I²C UART with 128-Word FIFOs in WLP

Detailed Description

The MAX3108A universal asynchronous receiver-transmitter (UART) bridges an SPI/MICROWIRE® or I²C microprocessor bus to an asynchronous serial-data communication link. The device contains an advanced UART, a fractional baud-rate generator, and four GPIOs. Eight-bit registers configure and monitor the device and are accessed through SPI or I²C, selectable by an external pin. The registers are organized by related function as shown in the *Register Map* section.

The host controller loads data into the Transmit Hold register (**THR**) through the SPI or I²C interface. This data is automatically pushed into the transmit first-in/first-out (FIFO), formatted, and sent out at TX. The device adds START, STOP, and parity bits to the data before transmitting at the selected baud rate. The clock configuration registers determine the baud rate, clock source, and clock frequency prescaling.

The MAX3108A receiver detects a START bit as a high-to-low transition on RX. An internal clock samples this data at 16 times the baud rate. The received data is automatically placed in the receive FIFO and can be read out by the host microcontroller through the Receive Hold register (**RHR**).

The MAX3108A's register set is compatible with the MAX3107.

Register Set

The device has a flat register structure without shadow registers. The registers are 8 bits wide. The registers have some similarities to the 16C550 registers.

Receive and Transmit FIFOs

The UART's receiver and transmitter each have a 128-word-deep FIFO, reducing the number of intervals that the host processor needs to dedicate for high-speed, high-volume data transfer to and from the device. As the data rates of the asynchronous Rx/Tx interfaces increase and get closer to those of the host controller's SPI/I²C data rates, UART management and flow-control can make up a significant portion of the host's activity. By increasing FIFO size, the host is interrupted less often and can use data block transfers to and from the FIFOs. FIFO trigger levels can generate interrupts to the host controller, signaling that programmed FIFO fill levels have been reached. The transmitter and receiver trigger

levels are programmed through the **FIFOTrgLvl** register with a resolution of eight FIFO locations. The receive FIFO trigger signals to the host either that the receive FIFO has a defined number of words waiting to be read out in a block or that a known number of vacant FIFO locations are available and ready to be filled. The transmit FIFO trigger generates an interrupt when the transmit FIFO fill level is above the programmed trigger level. The host then knows to throttle data writing to the transmit FIFO through **THR**.

The host can read out the number of words present in each of the FIFOs through the **TxFIFOLvl** and **RxFIFOLvl** registers. The contents of the Tx FIFO and Rx FIFO are both cleared when the **MODE2[1]: FIFORst** bit is set high. **Note:** The **TxFIFOLvl** and **RxFIFOLvl** values can be in error. See the **TxFIFOLvl** register description for details.

Transmitter Operation

Figure 3 shows the structure of the transmitter with the Tx FIFO. The transmit FIFO can hold up to 128 words of data that are added by writing to the **THR** register.

The transmit FIFO fill level can be programmed to generate an interrupt when more than a programmed number of words are present in the Tx FIFO through the

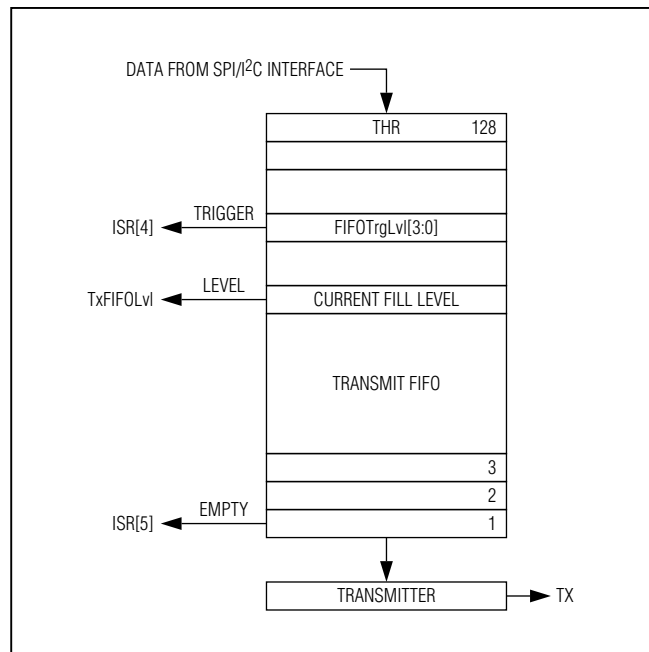

Figure 3. Transmit FIFO Signals

MICROWIRE is a registered trademark of National Semiconductor Corp.

MAX3108A

SPI/I²C UART with 128-Word FIFOs in WLP

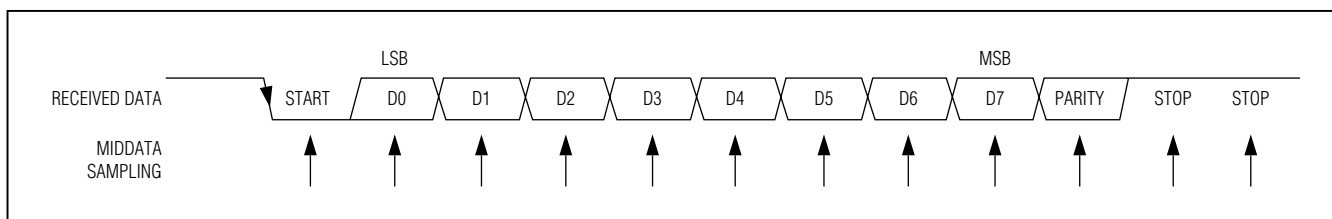

Figure 4. Receive Data Format

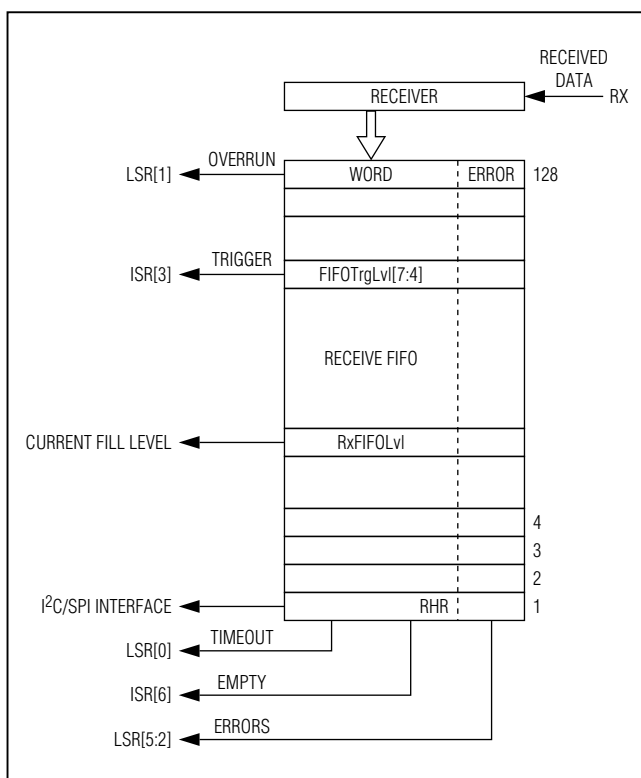

Figure 5. Receive FIFO

FIFOTrgLvl register. This Tx FIFO interrupt trigger level is selectable by the **FIFOTrgLvl[3:0]** bits. When the transmit FIFO fill level increases beyond the programmed trigger level, an interrupt is generated in **ISR[4]**: TxTrgInt. An interrupt is generated in **ISR[5]**: TxFifoEmptyInt when the transmit FIFO is empty. **ISR[5]** goes high when

the transmitter starts transmitting the last word in the Tx FIFO. An additional interrupt is generated in **STSIInt[7]**: TxEmptyInt when the transmitter completes transmitting the last word.

To halt transmission, set the **MODE1[1]**: TxDisabl bit high. After TxDisabl is set, the transmitter completes the transmission of the current character and then ceases transmission. Turn the transmitter off prior to enabling auto software flow control and AutoRTS flow control.

The TX output logic can be inverted through the **IrDA[5]**: TxInv bit. Unless otherwise noted, all transmitter logic described in this data sheet assumes that TxInv is set low.

Note: Errors in transmitted data can occur when the **THR** is being written to while the transmitter is sending data. See the **THR** register description for details.

Receiver Operation

The receiver expects the format of the data at RX to be as shown in Figure 4. The quiescent logic state is logic-high and the first bit (the START bit) is logic-low. The 8-bit data word is expected to be received LSB first. The receiver samples the data near the midbit instant (Figure 4). The received words and their associated errors are deposited into the receive FIFO. Errors and status information are stored for every received word (Figure 5). The host reads the data out of the receive FIFO by reading **RHR**, which comes out oldest data first. The status and error information for the word most recently read from **RHR** is located in the Line Status register (**LSR**). After a word is read out of **RHR**, **LSR** contains the status information for that word. **Note:** If data is read out of **RHR** simultaneously when the receiver is receiving data, errors can occur. See the **RHR** register description for details.

MAX3108A

SPI/I²C UART with 128-Word FIFOs in WLP

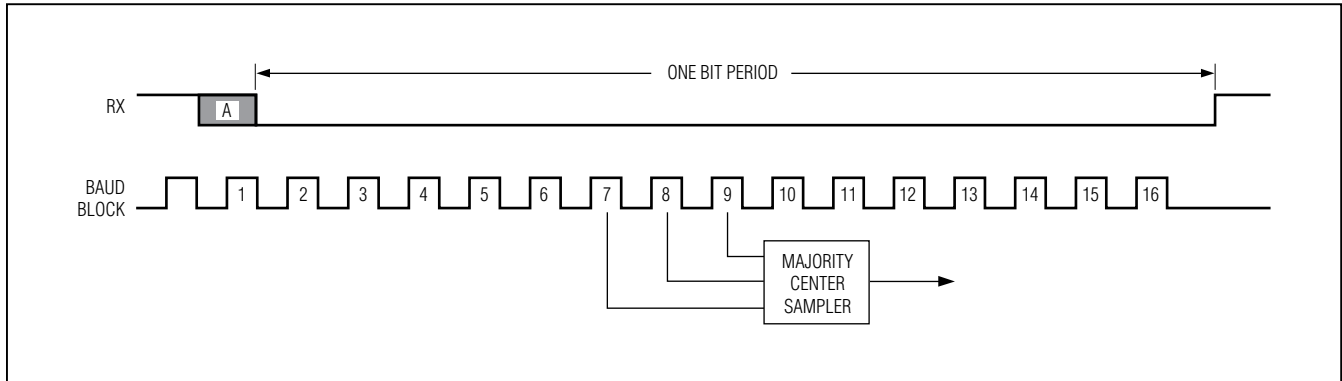

Figure 6. Midbit Sampling

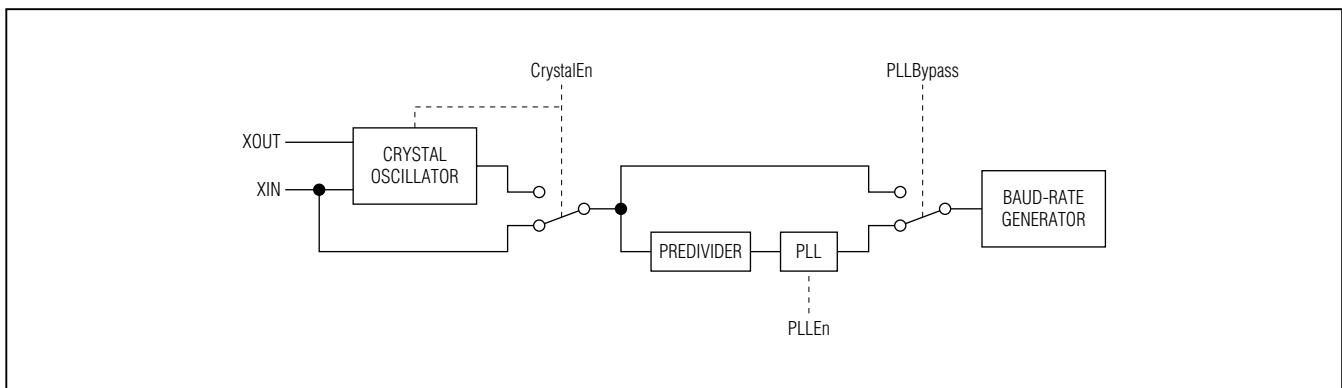

Figure 7. Clock Selection Diagram

The following three error conditions are checked for each received word: parity error, frame error, and noise on the line. Parity errors are detected by calculating either even or odd parity of the received word as programmed by register settings. Framing errors are detected when the received data frame does not match the expected frame format in length. Line noise is detected by checking the logical congruency of the three samples taken of each bit (Figure 6).

The receiver can be turned off by setting the **MODE1[0]**: RxDisabl bit high. After this bit is set high, the device turns the receiver off immediately following the current word and does not receive any further data.

The RX input logic can be inverted by setting the **IrDA[4]**: RxInv bit high. Unless otherwise noted, all receiver logic described in this data sheet assumes that RxInv is set low.

Line Noise Indication

When operating in standard or 2x (i.e., not 4x) rate mode, the device checks that the binary logic level of the three samples per received bit are identical. If any of the three samples per received bit have differing logic levels, then noise on the transmission line has affected the received data and it is considered to be noisy. This noise indication is reflected in the **LSR[5]**: RxNoise bit for each received byte. Parity errors are another indication of noise, but are not as sensitive.

MAX3108A

SPI/I²C UART with 128-Word FIFOs in WLP

Clock Selection

The device can be clocked by either an external crystal or an external clock source. Figure 7 shows a simplified diagram of the clock selection circuitry. When the device is clocked by a crystal, the **STSInt**[5]: ClkReady bit indicates when the crystal oscillator has reached steady state and the baud-rate generator is ready for stable operation.

The baud-rate clock can be routed to the $\overline{\text{RTS}}$ output by setting the **CLKSource**[7]: CLKtoRTS bit high. The clock rate is 16x the baud rate in standard operating mode, 8x the baud rate in 2x rate mode, and 4x the baud rate in 4x rate mode. If the fractional portion of the baud-rate generator is used, the clock is not regular and exhibits jitter.

Crystal Oscillator

The device is equipped with a crystal oscillator to provide high baud-rate accuracy and low power consumption. Set the **CLKSource**[1]: CrystalEn bit high to enable and select the crystal oscillator. The on-chip crystal oscillator has integrated load capacitances of 16pF in both the XIN and XOUT pins. Connect only an external crystal or ceramic oscillator between XIN and XOUT.

External Clock Source

Connect an external single-ended clock source to XIN when not using the crystal oscillator. Leave XOUT unconnected. Set the **CLKSource**[1]: CrystalEn bit low to select external clocking.

PLL and Predivider

The internal predivider and PLL allow for compatibility with a wide range of external clock frequencies and baud rates. The PLL can be configured to multiply the input clock rate by a factor of 6, 48, 96, or 144 by the **PLLConfig**[7:6] bits. The predivider is located between the input clock and the PLL and allows division of the input clock by an integer factor between 1 and 63. This value is defined by the **PLLConfig**[5:0] bits. See the **PLLConfig** register description for more information. Use of the PLL requires VCC to be higher than 2.35V.

Fractional Baud-Rate Generator

The internal fractional baud-rate generator provides a high degree of flexibility and high resolution in baud-rate programming. The baud-rate generator has a 16-bit integer divisor and a 4-bit word for the fractional divisor. The fractional baud-rate generator can be used either with the crystal oscillator or external clock source.

The integer and fractional divisors are calculated by the divisor, D:

$$D = \frac{f_{\text{REF}} \times \text{RateMode}}{16 \times \text{BaudRate}}$$

where f_{REF} is the reference frequency input to the baud-rate generator, RateMode is the rate mode multiplier (1x default), BaudRate is the desired baud rate, and D is the ideal divisor. f_{REF} must be less than 96MHz. RateMode is 1 in 1x rate mode, 2 in 2x rate mode, and 4 in 4x rate mode.

The integer divisor portion, DIV, of the divisor, D, is obtained by truncating D:

$$\text{DIV}(\text{decimal}) = \text{TRUNC}(D)$$

DIV can be a maximum of 16 bits (65,535) wide and is programmed into the two single-byte-wide registers **DIVMSB** and **DIVLSB**. The minimum allowed value for **DIVLSB** is 1.

The fractional portion of the divisor, FRACT, is a 4-bit nibble that is programmed into **BRGConfig**[3:0]. The maximum value is 15, allowing the divisor to be programmed with a resolution of 0.0625. FRACT is calculated as: $\text{FRACT} = \text{ROUND}(16 \times (D - \text{DIV}))$.

The following is an example of how to calculate the divisor. It is based on a required baud rate of 190kbaud and a 28.23MHz reference input frequency and 1x (default) rate mode.

The ideal divisor is calculated as:

$$D = 28,230,000 / (16 \times 190,000) = 9.286$$

hence DIV = 9.

$$\text{FRACT} = \text{ROUND}(16 \times 0.286) = 5$$

so **DIVMSB** = 0x00, **DIVLSB** = 0x09, and **BRGConfig**[3:0] = 0x05.

The resulting actual baud rate can be calculated as:

$$\text{BR}_{\text{ACTUAL}} = \frac{f_{\text{REF}} \times \text{RateMode}}{16 \times D_{\text{ACTUAL}}}$$

For this example: $D_{\text{ACTUAL}} = 9 + 5/16 = 9.3125$, RateMode = 1, and

$$\text{BR}_{\text{ACTUAL}} = 28,230,000 / (16 \times 9.3125) = 189,463 \text{ baud.}$$

Thus, the actual baud rate is within 0.28% of the ideal rate.

SPI/I²C UART with 128-Word FIFOs in WLP

2x and 4x Rate Modes

The device offers 2x and 4x rate modes to support higher baud rates than possible with standard operation using 16x sampling. In these modes, the reference clock rate only needs to be either 8x or 4x higher than the baud rate, respectively. In 4x rate mode, each received bit is only sampled once at the midbit instant instead of the usual three samples to determine the logic value of the received bit. This reduces the ability to detect line noise on the received data in 4x rate mode. The 2x and 4x rate modes are selectable through **BRGConfig**[5:4]. Note that IrDA encoding and decoding does not operate in 2x and 4x rate modes.

When 2x rate mode is selected, the actual baud rate is twice the rate programmed into the baud-rate generator. If 4x rate mode is enabled, the actual baud rate on the line is quadruple that of the programmed baud rate (Figure 8).

Multidrop Mode

In multidrop mode, also known as 9-bit mode, the data word length is 8 bits and a 9th bit is used for distinguishing between an address word and a data word. Multidrop mode is enabled by the **MODE2**[6]: MultiDrop bit. The MultiDrop bit takes the place of the parity bit in the data word structure. Parity checking is disabled and an interrupt is generated in **SpclCharInt**[5]: MultiDropInt when an address (9th bit is 1) is received while in multidrop mode.

It is up to the host processor to filter out the data intended for its address. Alternatively, the auto data-filtering feature can be used to automatically filter out the data not intended for the station's specific 9-bit mode address.

Auto Data Filtering in Multidrop Mode

In multidrop mode, the device can be configured to automatically filter out data that is not meant for its address. The address is user-definable either by programming a register value or a combination of a register value and GPIO hardware inputs. Use either the entire **XOFF2** register or the **XOFF2**[7:4] bits in combination with GPIO inputs to define the address.

Enable multidrop mode by setting the **MODE2**[6]: MultiDrop bit high and enable auto data filtering by setting the **MODE2**[4]: SpecialChr bit high.

When using register bits in combination with GPIO inputs to define the address, the MSB of the address is written to the **XOFF2**[7:4] bits, while the LSBs of the address are defined by the GPIOs. To enable this address-definition method along with auto data filtering, set the **FlowCtrl**[2]: GPIAddr bit high in addition to the **MODE2**[4]: SpecialChr and **MODE2**[6]: MultiDrop bits. The GPIO inputs are automatically read when the **FlowCtrl**[2]: GPIAddr bit is set high, and the address is automatically updated on logic changes to any GPIO pin.

When using auto data filtering, the device checks each received address against the programmed station address. When an address is received that matches the station's address, received data is stored in the RxFIFO. When an address is received that does not match the station's address, received data is discarded. Addresses are not stored into the FIFO but an interrupt is still generated in **SpclCharInt**[5]: MultiDropInt upon receiving an address. An additional interrupt is generated in **SpclCharInt**[3]: XOFF2Int when the station address is received.

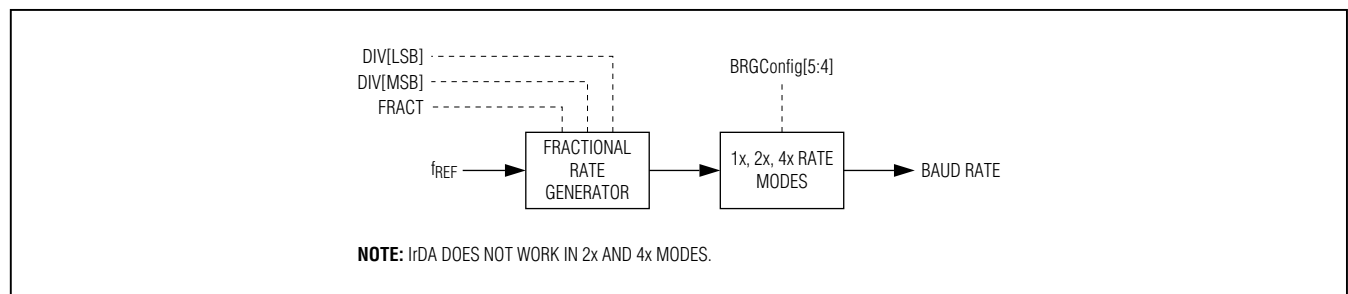

Figure 8. 2x and 4x Baud Rates

MAX3108A

SPI/I²C UART with 128-Word FIFOs in WLP

Auto Transceiver Direction Control

In some half-duplex communication systems, the transceiver's transmitter must be turned off when data is being received to avoid loading the bus. This is the case in half-duplex RS-485 communication. Similarly, in full-duplex multidrop communication such as RS-485 or RS-422 V.11, only one transmitter can be enabled at any one time while the others must be disabled. The device can be configured to automatically enable/disable a transceiver's transmitter and/or receiver at the hardware level by controlling its DE and \overline{RE} pins. This feature relieves the host processor of this time-critical task.

The \overline{RTS} output is used to control the transceivers' transmit-enable input and is automatically set high when the

device's transmitter starts transmission. This occurs as soon as data is present in the transmit FIFO. Auto transceiver direction control is enabled by the **MODE1**[4]: TrnscvCtrl bit. Figure 9 shows a typical connection in an RS-485 application using the auto transceiver direction control feature.

The \overline{RTS} output can be set high in advance of Tx transmission by a programmable time period called the setup time (Figure 10). The setup time is programmed by the **HDplxDelay**[7:4]: Setupx bits. Similarly, the \overline{RTS} output can be held high for a programmable period after the transmitter has completed transmission called the hold time. The hold time is programmed by the **HDplxDelay**[3:0]: Holdx bits.

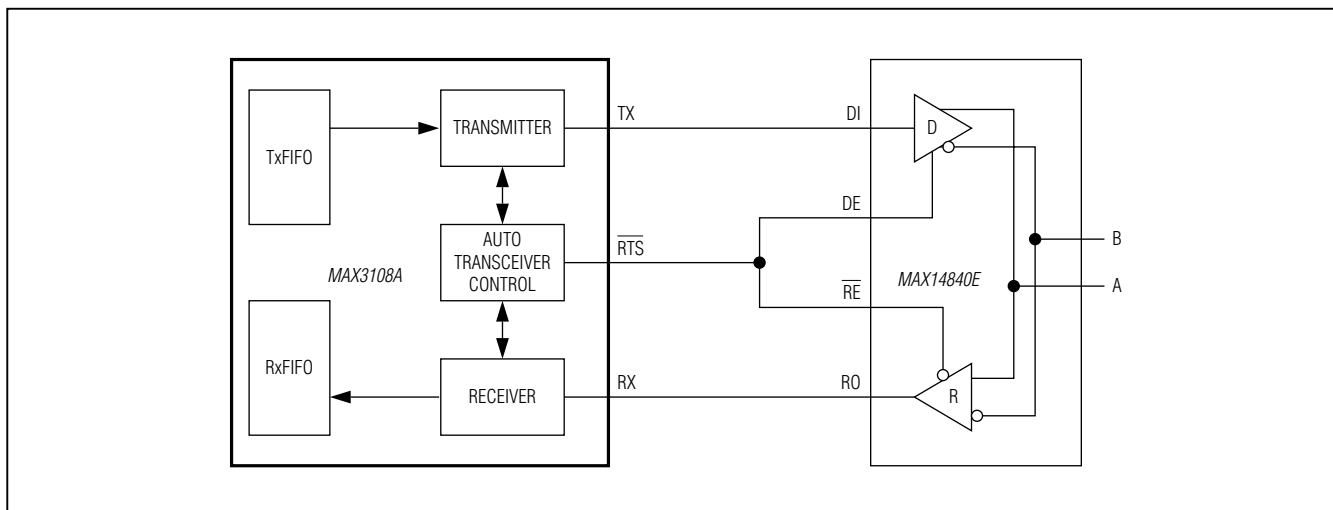

Figure 9. Auto Transceiver Direction Control

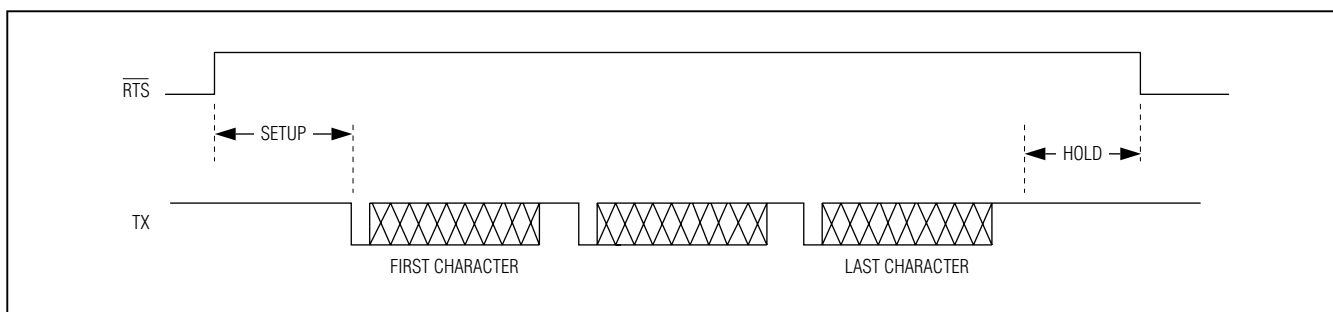

Figure 10. Setup and Hold times in Auto Transceiver Direction Control

SPI/I²C UART with 128-Word FIFOs in WLP

Echo Suppression

The device can suppress echoed data that is sometimes found in half-duplex communication networks, such as RS-485 and IrDA. If the transceiver's receiver is not turned off while the transceiver is transmitting, copies (echoes) of the transmitted data are received by the UART. The device's receiver can block the reception of this echoed data by enabling echo suppression. Figure 11 shows a typical RS-485 application using the echo suppression feature. Set the **MODE2**[7]: EchoSuprs bit high to enable echo suppression.

The device can also block echoes with a long round trip delay by disabling the transceiver's receiver with the $\overline{\text{RTS}}$ output while the device is transmitting. The transmitter can be configured to remain enabled after the end of the transmission for a programmable period of time called the hold time delay (Figure 12). The hold time delay is set by the **HDp1xDelay**[3:0] bits. See the **HDp1xDelay** description in the *Detailed Register Descriptions* section for more information.

Echo suppression can operate simultaneously with auto transceiver direction control.

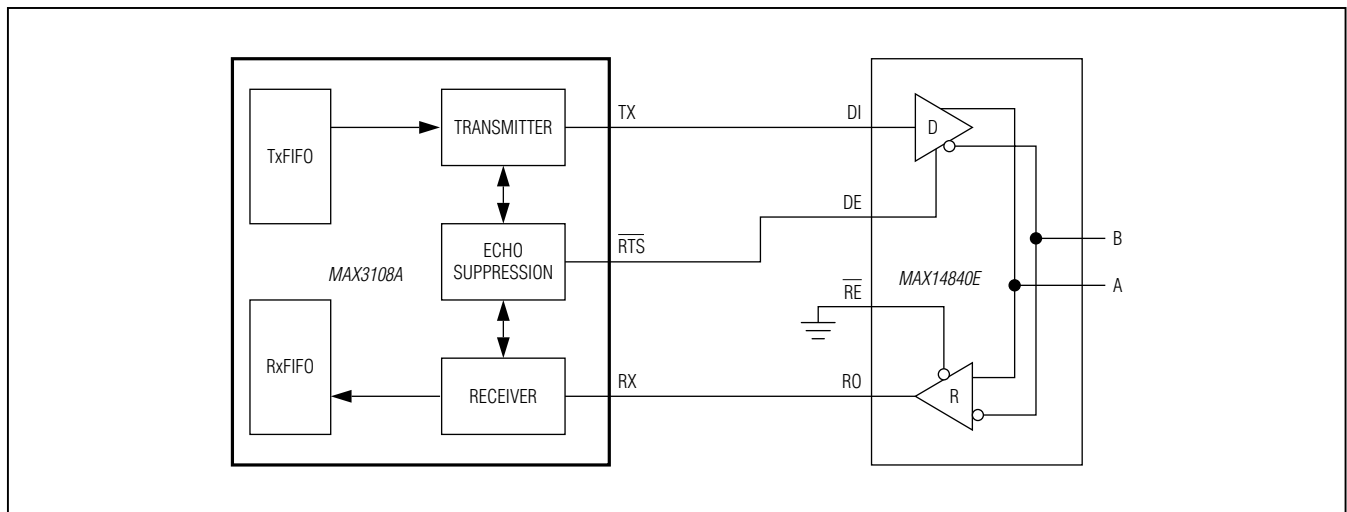

Figure 11. Half-Duplex with Echo Suppression

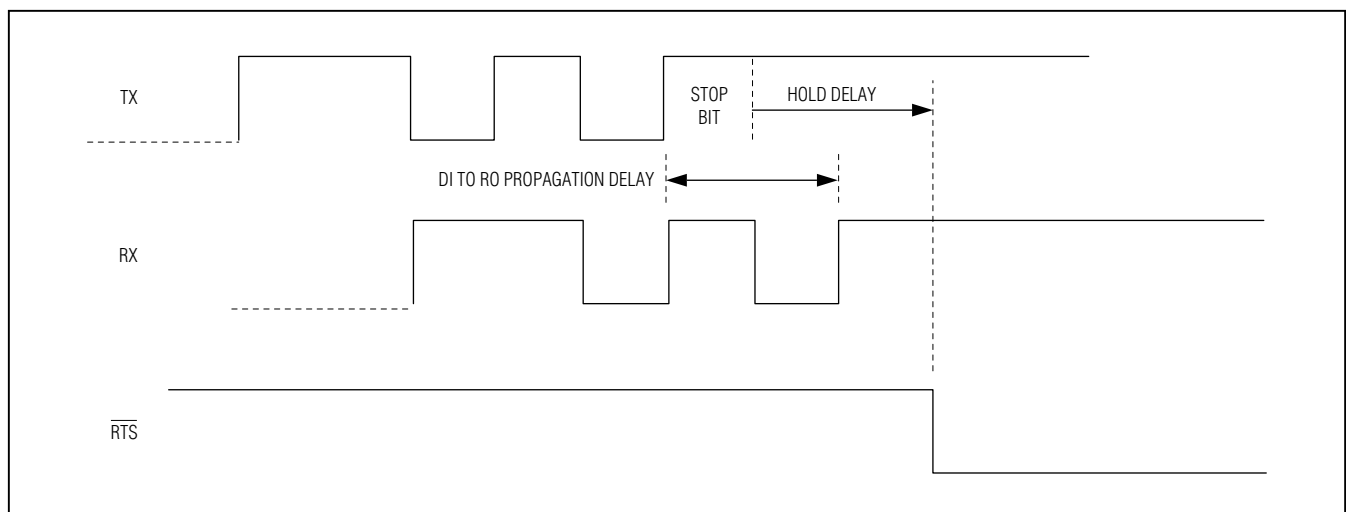

Figure 12. Echo Suppression Timing

MAX3108A

SPI/I²C UART with 128-Word FIFOs in WLP

Auto Hardware Flow Control

The device is capable of auto hardware ($\overline{\text{RTS}}$ and $\overline{\text{CTS}}$) flow control without the need for host processor intervention. When AutoRTS control is enabled, the device automatically controls the $\overline{\text{RTS}}$ handshake without the need for host processor intervention. AutoCTS flow control separately turns the device's transmitter on and off based on the $\overline{\text{CTS}}$ input. AutoRTS and AutoCTS flow control modes are independently enabled by the **FlowCtrl[1:0]** bits.

AutoRTS Control

AutoRTS flow control ensures that the receive FIFO does not overflow by signaling to the far-end UART to stop data transmission. The device does this automatically by controlling the $\overline{\text{RTS}}$ output. AutoRTS flow control is enabled by setting the **FlowCtrl[0]**: AutoRTS bit high. The HALT and RESUME programmable values determine the threshold RxFIFO fill levels at which $\overline{\text{RTS}}$ is asserted and deasserted. Set the HALT and RESUME levels in the **FlowLvl** register. With differing HALT and RESUME levels, hysteresis of the RxFIFO level can be defined for $\overline{\text{RTS}}$ transitions.

When the RxFIFO is filled to a level higher than the HALT level, the device deasserts $\overline{\text{RTS}}$ and stops the far-end UART from transmitting any additional data. $\overline{\text{RTS}}$ remains deasserted until the RxFIFO is emptied enough so that the number of words falls to below the RESUME level.

Interrupts are not generated when the HALT and RESUME levels are reached. This allows the host controller to be completely disengaged from $\overline{\text{RTS}}$ flow control management.

AutoCTS Control

When AutoCTS flow control is enabled, the UART automatically starts transmitting data when the $\overline{\text{CTS}}$ input is logic-low and stops transmitting data when $\overline{\text{CTS}}$ is logic-high. This frees the host processor from managing this time-critical flow-control task. AutoCTS flow control is enabled by setting the **FlowCtrl[1]**: AutoCTS bit high. The **ISR[7]**: CTSInt interrupt works normally during AutoCTS flow control. Set the **IRQEn[7]**: CTSIntEn bit low to disable routing of $\overline{\text{CTS}}$ interrupts to $\overline{\text{IRQ}}$ and ensure that the host does not receive interrupts from $\overline{\text{CTS}}$ transitions. If $\overline{\text{CTS}}$ transitions from low to high during transmission of a data word, the device completes the transmission of the current word and halts transmission afterwards.

Turn the transmitter off by setting the **MODE1[1]**: TxDisabl bit high before enabling AutoCTS control.

Auto Software (XON/XOFF) Flow Control

When auto software flow control is enabled, the device recognizes and/or sends predefined XON/XOFF characters to control the flow of data across the asynchronous serial link. The XON character signifies that there is enough room in the receive FIFO and transmission of data should continue. The XOFF character signifies that the receive FIFO is nearing overflow and that the transmission of data should stop. Auto software flow control works autonomously and does not require host intervention, similar to auto hardware flow control. To reduce the chance of receiving corrupted data that equals a single-byte XON or XOFF character, the device allows for double-wide (16-bit) XON/XOFF characters. The XON and XOFF characters are programmed into the **XON1**, **XON2** and **XOFF1**, **XOFF2** registers.

The **FlowCtrl[7:3]** bits are used for enabling and configuring auto software flow control. An interrupt is generated in **ISR[1]**: SpCharInt whenever an XON or XOFF character is received and details are stored in the **SpclCharInt** register. Set the **IRQEn[1]**: SpclChriEn bit low to disable routing of the interrupt to $\overline{\text{IRQ}}$.

Software flow control consists of transmit flow control and receive flow control, which operate independently of each other.

Receiver Flow Control

When auto receive flow control is enabled by the **FlowCtrl[7:6]** bits, the device automatically controls the transmission of data by the far-end UART by sending XOFF and XON control characters. The HALT and RESUME levels determine the threshold RxFIFO fill levels at which the XOFF and XON characters are sent. HALT and RESUME are programmed in the **FlowLvl** register. With differing HALT and RESUME levels, hysteresis can be defined in the RxFIFO fill level for the receiver flow control activity.

When the RxFIFO is filled to a level higher than the HALT level, the device sends an XOFF character to stop data transmission. An XON character is sent when the RxFIFO is emptied enough so that the number of words falls to below the RESUME level.

If double-wide (16-bit) XON/XOFF characters are selected by setting the **FlowCtrl[7:6]** bits to 11, then **XON1/XOFF1** are transmitted before **XON2/XOFF2** whenever a control character is transmitted.

Transmitter Flow Control

If auto transmit control is enabled by the **FlowCtrl[5:4]** bits, the receiver compares all received words with the

SPI/I²C UART with 128-Word FIFOs in WLP

XOFF and XON characters. When an XOFF character is received, the device halts the transmitter from sending further data following any currently transmitting word. The receiver is not affected and continues receiving. Upon receiving an XON character, the transmitter restarts sending data. The received XON and XOFF characters are filtered out and are not stored into the receive FIFO. An interrupt is not generated.

If double-wide (16-bit) XON/XOFF characters are selected by setting the **FlowCtrl**[5:4] bits to 11, then a character matching **XON1/XOFF1** must be received before a character matching **XON2/XOFF2** to be interpreted as a control character.

Turn the transmitter off by setting the **MODE1**[1]: TxDisabl bit high before enabling software transmitter flow control.

FIFO Interrupt Triggering

Receive and transmit FIFO fill-dependent interrupts are generated if FIFO trigger levels are defined. When the number of words in the FIFOs reach or exceed a trigger level programmed in the **FIFOTrgLvl** register, an interrupt is generated in **ISR**[3] or **ISR**[4]. The interrupt trigger levels operate independently from the HALT and RESUME flow control levels in AutoRTS or auto software flow control modes.

The FIFO interrupt triggering can be used, for example, for a block data transfer. The trigger level interrupt gives the host an indication that a given block size of data is available for reading in the receive FIFO or available for transfer to the transmit FIFO. If the HALT and RESUME levels are outside of this range, then the UART continues to transmit or receive data during the block read/write operations for uninterrupted data transmission on the bus.

Low-Power Standby Modes

The device has sleep and shutdown modes that reduce power consumption during periods of inactivity. In both sleep and shutdown modes, the UART disables specific functional blocks to reduce power consumption.

After sleep or shutdown mode is exited, the internal clock starts up and a period of time is needed for clock stabilization. The **STSInt**[5]: ClkReady bit indicates when the clocks are stable. When an external clock source is used, the ClkReady bit does not indicate clock stability.

Forced-Sleep Mode

In forced-sleep mode, all UART-related on-chip clocking is stopped. The following blocks are inactive: the crystal oscillator, the PLL, the predivider, the receiver,

and the transmitter. The I²C/SPI interface and the registers remain active and the host controller can access them. To force the device to enter sleep mode, set the **MODE1**[5]: ForcedSleep bit high. To exit forced-sleep mode, set the ForcedSleep bit low.

Auto-Sleep Mode

The device can be configured to operate in auto-sleep mode by setting the **MODE1**[6]: AutoSleep bit high. In auto-sleep mode, the device automatically enters sleep mode when all the following conditions are met:

- Both FIFOs are empty.
- There are no pending $\overline{\text{IRQ}}$ interrupts.
- There is no activity on any input pins for a period equal to 65,536 UART character lengths.

The same blocks are inactive when the UART is in auto-sleep mode as in forced-sleep mode.

The device exits auto-sleep mode as soon as activity is detected on any of the GPIO_, RX, or $\overline{\text{CTS}}$ inputs.

To manually exit auto-sleep mode, set the **MODE1**[6]: AutoSleep bit low.

Shutdown Mode

Drive the $\overline{\text{RST}}$ input to logic-low to enter shutdown mode. Shutdown mode consumes less than 1 μ A. In shutdown mode, all the device's circuitry is completely off. This includes the I²C/SPI interface, the registers, the FIFOs, and the clocking circuitry.

When the $\overline{\text{RST}}$ input transitions from low to high, the device exits shutdown mode and a hardware reset is initiated. The chip initialization is complete when the controller is able to read out known register contents from the device. This could, for example, be the DIVLSB register.

The device needs to be reprogrammed following a shutdown.

Power-Up and $\overline{\text{IRQ}}$

The $\overline{\text{IRQ}}$ output only operates when all supplies are active. $\overline{\text{IRQ}}$ operates as a hardware active-low interrupt output; $\overline{\text{IRQ}}$ is asserted when an interrupt is pending. An $\overline{\text{IRQ}}$ interrupt is only possible during normal operation if at least one of the interrupt enable bits in the IRQEN register is set.

MAX3108A

SPI/I²C UART with 128-Word FIFOs in WLP

In polled mode, any register with a known reset value can be polled to check whether the device is ready for operation. If the controller gets a valid response from the polled register, then the device is ready for operation.

Interrupt Structure

Figure 13 shows the structure of the interrupt. There are four interrupt source registers: **ISR**, **LSR**, **STSInt**, and **SpclCharInt**. The interrupt sources are divided into top-level and low-level interrupts. The top-level interrupts typically occur more often and can be read out by the host controller directly through **ISR**. The low-level interrupts typically occur less often and their specific source can be read out by the host controller through **LSR**, **STSInt**, or **SpclCharInt**. The three LSBs of **ISR** point to the low-level interrupt registers that contain the details of the interrupt source.

Interrupt Enabling

Every interrupt bit of the four interrupt registers can be enabled or masked through an associated interrupt enable register bit. These are the **IRQEn**, **LSRIntEn**, **SpclCharIntEn**, and **STSIntEn** registers. By default, all interrupts are masked.

Interrupt Clearing

When an interrupt is pending (i.e., $\overline{\text{IRQ}}$ is asserted) and **ISR** is read, both the **ISR** bits are cleared and the $\overline{\text{IRQ}}$ output is deasserted. Low-level interrupt information does not reassert $\overline{\text{IRQ}}$ for the same interrupt, but remains stored in the low-level interrupt registers until each is separately cleared. **SpclCharInt** and **STSInt** are clear-on-read (COR). The **LSR** bits are only cleared when the source of the interrupt is removed, not when **LSR** is read.

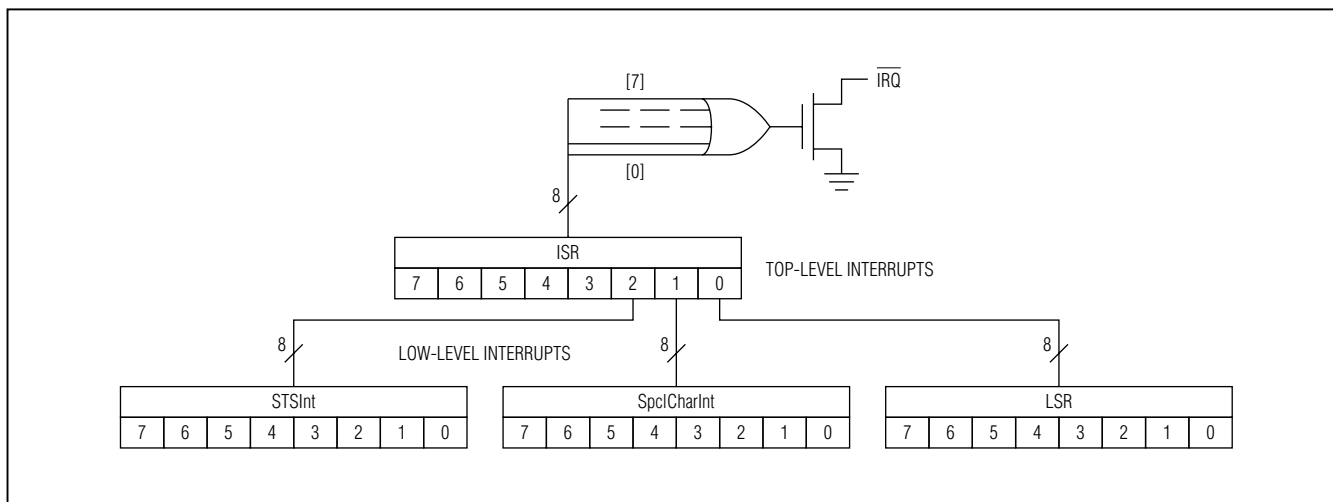

Figure 13. Simplified Interrupt Structure

MAX3108A

SPI/I²C UART with 128-Word FIFOs in WLP

Register Map

(Note: All default reset values are 0x00, unless otherwise noted. All registers are R/W, unless otherwise noted.)

REGISTER	ADDR	BIT 7	BIT 6	BIT 5	BIT 4	BIT 3	BIT 2	BIT 1	BIT 0
FIFO DATA									
RHR ¹	0x00	RData7	RData6	RData5	RData4	RData3	RData2	RData1	RData0
THR ¹	0x00	TData7	TData6	TData5	TData4	TData3	TData2	TData1	TData0
INTERRUPTS									
IRQEn	0x01	CTSIEn	RxEmtlyEn	TFifoEmtlyEn	TxTrglEn	RxTrglEn	STSIEn	SpChrIEn	LSRErrIEn
ISR ^{1, 2}	0x02	CTSInt	RFifoEmptyInt	TFifoEmptyInt	TxTrglInt	RxTrglInt	STSIInt	SpCharInt	LSRErrInt
LSRIntEn	0x03	—	—	NoiseIntEn	RBreakIEn	FrameErrIEn	ParityIEn	ROverrrIEn	RTimoutIEn
LSR ¹	0x04	CTSbit	—	RxNoise	RxBreak	FrameErr	RxParityErr	RxOverrun	RTimeout
SpclChrIntEn	0x05	—	—	MitDrpIntEn	BREAKIntEn	XOFF2IntEn	XOFF1IntEn	XON2IntEn	XON1IntEn
SpclCharInt ¹	0x06	—	—	MultiDropInt	BREAKInt	XOFF2Int	XOFF1Int	XON2Int	XON1Int
STSIIntEn	0x07	TxEmpyIntEn	SleepIntEn	ClkRdyIntEn	—	GP13IntEn	GP12IntEn	GP11IntEn	GP10IntEn
STSIInt ¹	0x08	TxEmpyInt	SleepInt	ClkReady	—	GP13Int	GP12Int	GP11Int	GP10Int
UART MODES									
MODE1	0x09	—	AutoSleep	ForcedSleep	TrnscvCtrl	RTSHiZ	TXHiZ	TxDisabl	RxDisabl
MODE2	0x0A	EchoSuprs	MultiDrop	Loopback	SpecialChr	RFifoEmptyInv	RxTrglInv	FIFORst	RST
LCR ²	0x0B	RTSbit	TxBreak	ForceParity	EvenParity	ParityEn	StopBits	Length1	Length0
RxTimeOut	0x0C	TimOut7	TimOut6	TimOut5	TimOut4	TimOut3	TimOut2	TimOut1	TimOut0
HDplxDelay	0x0D	Setup3	Setup2	Setup1	Setup0	Hold3	Hold2	Hold1	Hold0
IrDA	0x0E	—	—	TxInv	RxInv	MIR	—	SIR	IrDAEn
FIFOs CONTROL									
FlowLvl	0x0F	Resume3	Resume2	Resume1	Resume0	Halt3	Halt2	Halt1	Halt0
FIFOTrgLvl ²	0x10	RxTrig3	RxTrig2	RxTrig1	RxTrig0	TxTrig3	TxTrig2	TxTrig1	TxTrig0
TxFIFOLvl ¹	0x11	TxFL7	TxFL6	TxFL5	TxFL4	TxFL3	TxFL2	TxFL1	TxFL0
RxFIFOLvl ¹	0x12	RxFL7	RxFL6	RxFL5	RxFL4	RxFL3	RxFL2	RxFL1	RxFL0
FLOW CONTROL									
FlowCtrl	0x13	SwFlow3	SwFlow2	SwFlow1	SwFlow0	SwFlowEn	GP1Addr	AutoCTS	AutoRTS
XON1	0x14	Bit7	Bit6	Bit5	Bit4	Bit3	Bit2	Bit1	Bit0
XON2	0x15	Bit7	Bit6	Bit5	Bit4	Bit3	Bit2	Bit1	Bit0
XOFF1	0x16	Bit7	Bit6	Bit5	Bit4	Bit3	Bit2	Bit1	Bit0
XOFF2	0x17	Bit7	Bit6	Bit5	Bit4	Bit3	Bit2	Bit1	Bit0
GPIOs									
GPIOConfig	0x18	GP3OD	GP2OD	GP1OD	GP0OD	GP3Out	GP2Out	GP1Out	GP0Out
GPIOData	0x19	GP13Dat	GP12Dat	GP11Dat	GP10Dat	GP03Dat	GP02Dat	GP01Dat	GP00Dat
CLOCK CONFIGURATION									
PLLConfig ²	0x1A	PLLFactor1	PLLFactor0	PreDiv5	PreDiv4	PreDiv3	PreDiv2	PreDiv1	PreDiv0
BRGConfig	0x1B	—	—	4xMode	2xMode	FRACT3	FRACT2	FRACT1	FRACT0
DIVLSB ²	0x1C	Div7	Div6	Div5	Div4	Div3	Div2	Div1	Div0
DIVMSB	0x1D	Div15	Div14	Div13	Div12	Div11	Div10	Div9	Div8
CLKSource ²	0x1E	CLKtoRTS	—	—	—	PLLBypass	PLLEn	CrystalEn	—

¹Denotes nonread/write mode: RHR = R, THR = W, ISR = COR, LSR = R, SpclCharInt = COR, STSIInt = R/COR, TxFIFOLvl = R, RxFIFOLvl = R.

²Denotes nonzero default reset value: ISR = 0x60, LCR = 0x05, FIFOTrgLvl = 0xFF, PLLConfig = 0x01, DIVLSB = 0x01, CLKSource = 0x18.