



Chipsmall Limited consists of a professional team with an average of over 10 year of expertise in the distribution of electronic components. Based in Hongkong, we have already established firm and mutual-benefit business relationships with customers from,Europe,America and south Asia,supplying obsolete and hard-to-find components to meet their specific needs.

With the principle of “Quality Parts,Customers Priority,Honest Operation,and Considerate Service”,our business mainly focus on the distribution of electronic components. Line cards we deal with include Microchip,ALPS,ROHM,Xilinx,Pulse,ON,Everlight and Freescale. Main products comprise IC,Modules,Potentiometer,IC Socket,Relay,Connector.Our parts cover such applications as commercial,industrial, and automotives areas.

We are looking forward to setting up business relationship with you and hope to provide you with the best service and solution. Let us make a better world for our industry!



Contact us

Tel: +86-755-8981 8866 Fax: +86-755-8427 6832

Email & Skype: info@chipsmall.com Web: www.chipsmall.com

Address: A1208, Overseas Decoration Building, #122 Zhenhua RD., Futian, Shenzhen, China



MAX31725/MAX31726

±0.5°C Local Temperature Sensors

General Description

The MAX31725/MAX31726 temperature sensors accurately measure temperature and provide an overtemperature alarm/interrupt/shutdown output. These devices convert the temperature measurements to digital form using a high-resolution, sigma-delta, analog-to-digital converter (ADC). Accuracy is ±0.5°C from -40°C to +105°C. Communication is through an I²C-compatible 2-wire serial interface.

The I²C serial interface accepts standard write byte, read byte, send byte, and receive byte commands to read the temperature data and configure the behavior of the open-drain overtemperature shutdown output.

The MAX31725 features three address select lines with a total of 32 available addresses. The MAX31726 features two address select lines with a total of 16 available addresses and a $\overline{\text{RESET}}$ input. The sensors have a 2.5V to 3.7V supply voltage range, low 600µA supply current, and a lockup-protected I²C-compatible interface that make them ideal for a wide range of applications, including PCs, electronic test equipment, and office electronics.

Both devices are available in an 8-pin TDFN package and operate over the -55°C to +150°C temperature range.

Benefits and Features

- ◆ **High Accuracy and Low-Voltage Operation Aids Designers in Meeting Error and Power Budgets**
 - ◇ ±0.5°C Accuracy from -40°C to +105°C
 - ◇ 16-Bit (0.00390625°C) Temperature Resolution
 - ◇ 2.5V to 3.7V Supply Voltage Range
- ◆ **One-Shot and Shutdown Modes Help Reduce Power Usage**
 - ◇ 925µA (max) Operating Supply Current
- ◆ **Extended Temperature Range Enables Measurements in High Temperature Systems (Measures Up to +150°C)**
- ◆ **Digital Functions Make Integration Easier into Any System**
 - ◇ Selectable Timeout Prevents Bus Lockup (Default Enabled for MAX31725; Default Disabled for MAX31726)
 - ◇ Separate Open-Drain OS Output Operates as Interrupt or Comparator/Thermostat Output
 - ◇ RESET Input (MAX31726)

Applications

Servers	Telecom
Networking	Industrial

[Ordering Information](#) appears at end of data sheet.

Typical Application Circuits

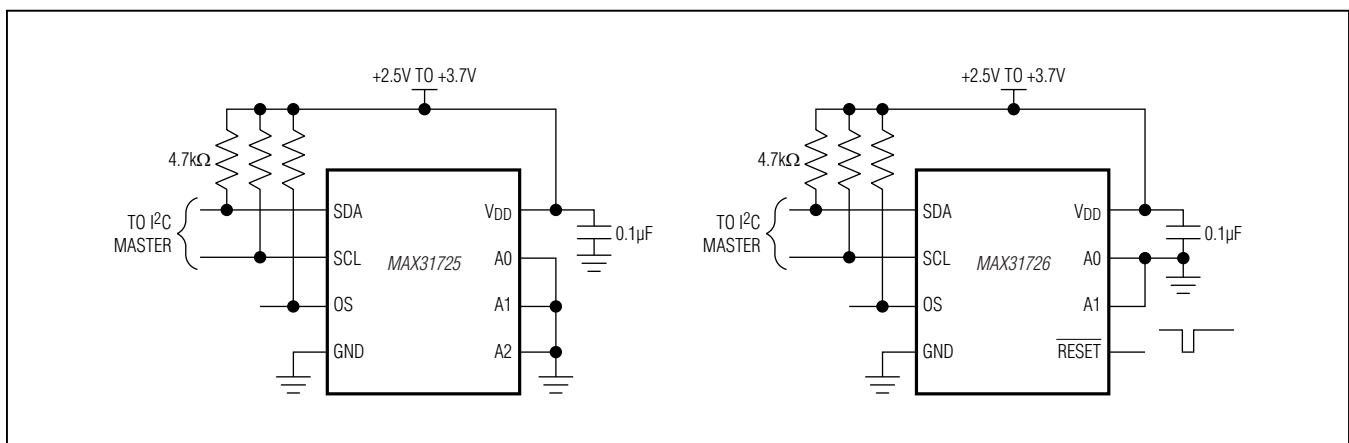

For related parts and recommended products to use with this part, refer to: www.maximintegrated.com/MAX31725.related

For pricing, delivery, and ordering information, please contact Maxim Direct at 1-888-629-4642, or visit Maxim Integrated's website at www.maximintegrated.com.

MAX31725/MAX31726

±0.5°C Local Temperature Sensors

ABSOLUTE MAXIMUM RATINGS

(All voltages relative to GND.)

Voltage Range on V_{DD} , SDA, SCL, A0, A1 -0.3V to +4V
 Voltage Range on A2, $\overline{\text{RESET}}$, OS -0.3V to ($V_{DD} + 0.3V$)
 Input Current at Any Pin +5mA
 Package Input Current +20mA
 Continuous Power Dissipation ($T_A = +70^\circ\text{C}$)
 TDFN (derate 24.4mW/°C above +70°C) 1951.2mW

ESD Protection (All Pins, Human Body Model) (Note 1).... ±4000V
 Operating Temperature Range -55°C to +150°C
 Junction Temperature +150°C
 Storage Temperature Range -65°C to +150°C
 Lead Temperature (soldering, 10s) +300°C
 Soldering Temperature (reflow) +260°C

Note 1: Human Body Model, 100pF discharged through a 1.5kΩ resistor.

Stresses beyond those listed under "Absolute Maximum Ratings" may cause permanent damage to the device. These are stress ratings only, and functional operation of the device at these or any other conditions beyond those indicated in the operational sections of the specifications is not implied. Exposure to absolute maximum rating conditions for extended periods may affect device reliability.

PACKAGE THERMAL CHARACTERISTICS (Note 2)

TDFN

Junction-to-Ambient Thermal Resistance (θ_{JA}) 41°C/W
 Junction-to-Case Thermal Resistance (θ_{JC}) 8°C/W

Note 2: Package thermal resistances were obtained using the method described in JEDEC specification JESD51-7, using a four-layer board. For detailed information on package thermal considerations, refer to www.maximintegrated.com/thermal-tutorial.

RECOMMENDED OPERATING CONDITIONS

($T_A = -55^\circ\text{C}$ to +150°C, unless otherwise noted.) (Notes 3, 4)

PARAMETER	SYMBOL	CONDITIONS	MIN	TYP	MAX	UNITS
Operating Supply Voltage	V_{DD}		2.5	3.3	3.7	V
Input High Voltage	V_{IH}		$V_{DD} \times 0.7$			V
Input Low Voltage	V_{IL}		$V_{DD} \times 0.3$			V

ELECTRICAL CHARACTERISTICS

($V_{DD} = 2.5V$ to 3.7V, $T_A = -55^\circ\text{C}$ to +150°C, unless otherwise noted. Typical values are $V_{DD} = 3.3V$, $T_A = +25^\circ\text{C}$.) (Note 3)

PARAMETER	SYMBOL	CONDITIONS	MIN	TYP	MAX	UNITS
Accuracy (Note 5)		$2.5V \leq V_{DD} \leq 3.7V$, $-40^\circ\text{C} \leq T_A \leq +105^\circ\text{C}$	-0.5	±0.1	+0.5	°C
		$2.5V \leq V_{DD} \leq 3.7V$, $-55^\circ\text{C} \leq T_A \leq +150^\circ\text{C}$	-0.7		+0.7	
Temperature Conversion Noise			0.0625			°C
Temperature Data Resolution			16	16		Bits
Conversion Time			44		50	ms
First Conversion Completed		Data ready after POR			50	ms
Quiescent Supply Current	I_{DD}	I ² C inactive, $T_A = -40^\circ\text{C}$ to +125°C	600		925	µA
		Shutdown mode, I ² C inactive, $T_A = -40^\circ\text{C}$ to +125°C	2.5		3.5	
		I ² C inactive, $T_A = +150^\circ\text{C}$	800			
		Shutdown mode, I ² C inactive, $T_A = +150^\circ\text{C}$	4.2			

MAX31725/MAX31726

±0.5°C Local Temperature Sensors

ELECTRICAL CHARACTERISTICS (continued)

($V_{DD} = 2.5V$ to $3.7V$, $T_A = -55^{\circ}C$ to $+150^{\circ}C$, unless otherwise noted. Typical values are $V_{DD} = 3.3V$, $T_A = +25^{\circ}C$.) (Note 3)

PARAMETER	SYMBOL	CONDITIONS	MIN	TYP	MAX	UNITS
OS Delay		Depends on fault queue setting	1		6	Conversions
T_{OS} Default Temperature		Factory default setting	80	80	80	$^{\circ}C$
T_{HYST} Default Temperature		Factory default setting	75	75	75	$^{\circ}C$
POR Voltage Threshold				2.26		V
POR Hysteresis				130		mV
Input-High Leakage Current	I_{IH}	$V_{IN} = 3.3V$ (all digital inputs)		0.005	1	μA
Input-Low Leakage Current	I_{IL}	$V_{IN} = 0V$ (all digital inputs)		0.005	1	μA
Input Capacitance		All digital inputs		5		pF
Output-High Leakage Current		$V_{IN} = 3.3V$ (SDA and OS)			1	μA
OS Output Saturation Voltage		$I_{OUT} = 4.0mA$			0.8	V
Output Low Voltage		$I_{OL} = 3mA$ (SDA)			0.4	V

I²C AC ELECTRICAL CHARACTERISTICS

($V_{DD} = 2.5V$ to $3.7V$, $T_A = -55^{\circ}C$ to $+150^{\circ}C$, unless otherwise noted. Typical values are $V_{DD} = 3.3V$, $T_A = +25^{\circ}C$.) (Notes 3, 6) (Figure 1)

PARAMETER	SYMBOL	CONDITIONS	MIN	TYP	MAX	UNITS
Serial Clock Frequency	f_{SCL}	(Note 7)	DC		400	kHz
Minimum RESET Pulse Width	t_{RESET}	MAX31726 only	100			ns
Bus Free Time Between STOP and START Conditions	t_{BUF}		1.3			μs
START Condition Hold Time	$t_{HD:STA}$		0.6			μs
STOP Condition Setup Time	$t_{SU:STO}$	90% of SCL to 10% of SDA	600			ns
Clock Low Period	t_{LOW}		1.3			μs
Clock High Period	t_{HIGH}		0.6			μs
START Condition Setup Time	$t_{SU:STA}$	90% of SCL to 90% of SDA	100			ns
Data Setup Time	$t_{SU:DAT}$	10% of SDA to 10% of SCL	100			ns
Data Out Hold Time	t_{DH}	(Note 8)	100			ns
Data In Hold Time	$t_{HD:DAT}$	10% of SCL to 10% of SDA (Note 8)	0		0.9	μs
Maximum Receive SCL/SDA Rise Time	t_R	(Note 9)		300		ns
Minimum Receive SCL/SDA Rise Time	t_R	(Note 9)		20 + 0.1 C_B		ns
Maximum Receive SCL/SDA Fall Time	t_F	(Note 9)		300		ns
Minimum Receive SCL/SDA Fall Time	t_F	(Note 9)		20 + 0.1 C_B		ns
Transmit SDA Fall Time	t_F	(Note 9)	20 + 0.1 C_B		250	ns

MAX31725/MAX31726

±0.5°C Local Temperature Sensors

I²C AC ELECTRICAL CHARACTERISTICS (continued)

(V_{DD} = 2.5V to 3.7V, T_A = -55°C to +150°C, unless otherwise noted. Typical values are V_{DD} = 3.3V, T_A = +25°C.) (Notes 3, 6) (Figure 1)

PARAMETER	SYMBOL	CONDITIONS	MIN	TYP	MAX	UNITS
Pulse Width of Suppressed Spike	t _{SP}	(Note 10)	0		50	ns
SDA Time Low for Reset of Serial Interface	t _{TIMEOUT}	(Note 7)	45	50	55	ms

- Note 3:** Limits are 100% production tested at T_A = +25°C and/or T_A = +85°C. Limits over the operating temperature range and relevant supply voltage range are guaranteed by design and characterization. Typical values are not guaranteed.
- Note 4:** All voltages are referenced to ground. Currents entering the IC are specified positive.
- Note 5:** These limits represent a 3-sigma distribution.
- Note 6:** All timing specifications are guaranteed by design.
- Note 7:** Holding the SDA line low for a time greater than t_{TIMEOUT} causes the devices to reset SDA to the idle state of the serial bus communication (SDA released).
- Note 8:** A master device must provide a hold time of at least 300ns for the SDA signal to bridge the undefined region of SCL's falling edge.
- Note 9:** C_B = total capacitance of one bus line in pF. Tested with C_B = 400pF.
- Note 10:** Input filters on SDA and SCL suppress noise spikes less than 50ns.

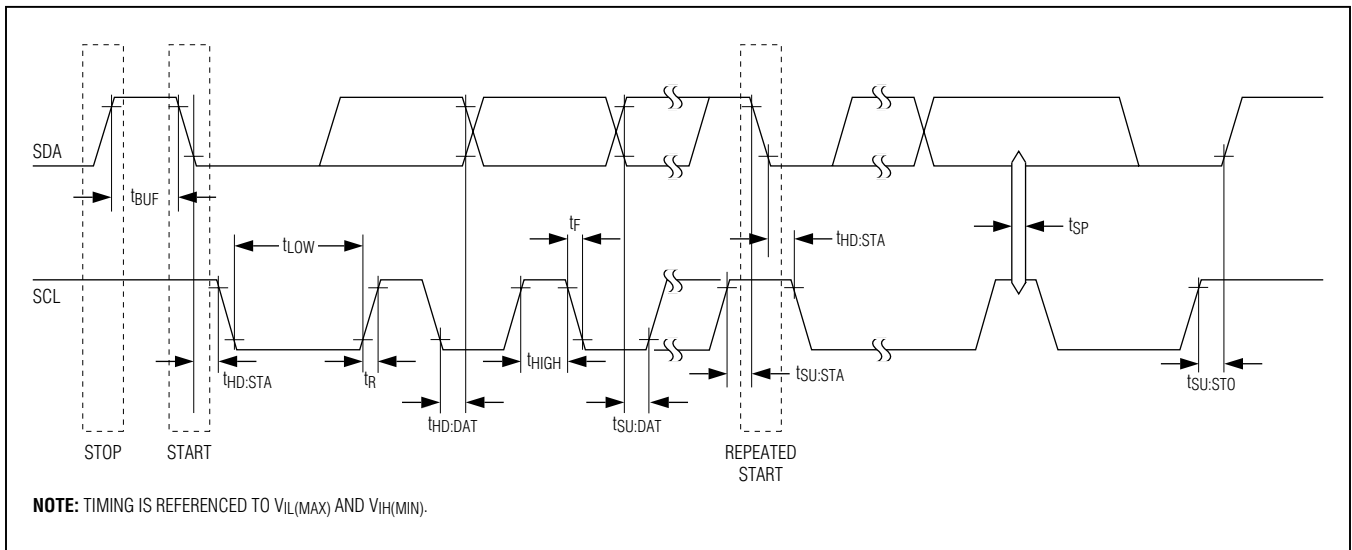

Figure 1. I²C Timing Diagram

MAX31725/MAX31726

±0.5°C Local Temperature Sensors

Typical Operating Characteristics

($T_A = +25^\circ\text{C}$, unless otherwise noted.)

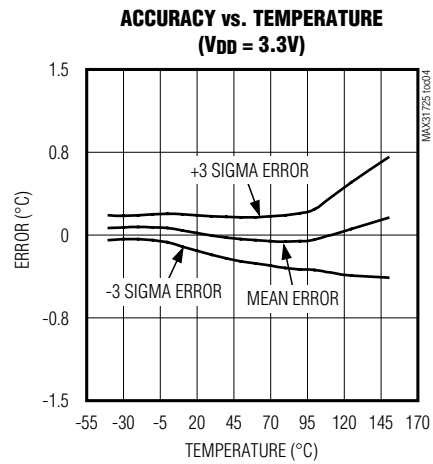
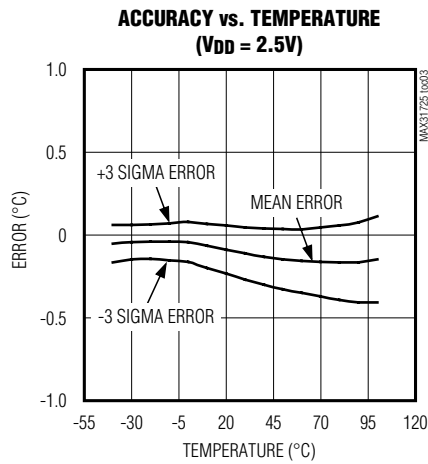
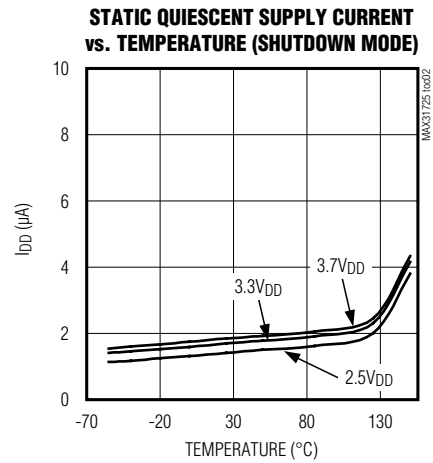
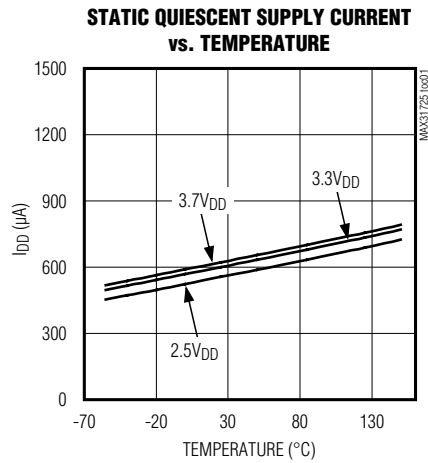

MAX31725/MAX31726

±0.5°C Local Temperature Sensors

Pin Configuration

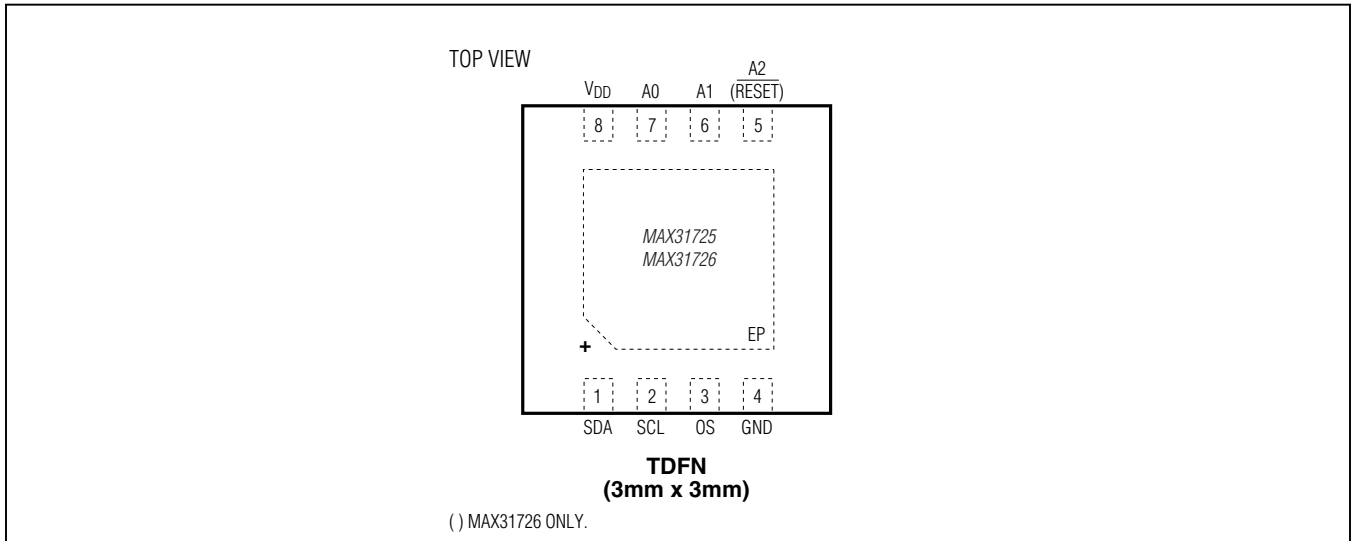

Pin Description

PIN		NAME	FUNCTION
MAX31725	MAX31726		
1	1	SDA	Serial-Data Input/Output Line. Open drain. Connect SDA to a pullup resistor. High impedance for supply voltages from 0 to 3.7V.
2	2	SCL	Serial-Data Clock Input. Open drain. Connect SCL to a pullup resistor. High impedance for supply voltages from 0 to 3.7V.
3	3	OS	Overtemperature Shutdown Output. Open drain. Connect OS to a pullup resistor.
4	4	GND	Ground
5	—	A2	I ² C Slave Address Input. Connect A2 to GND or V _{DD} to set the desired I ² C bus address. Do not leave unconnected (Table 1).
—	5	$\overline{\text{RESET}}$	Active-Low Reset Input. Pull $\overline{\text{RESET}}$ low for longer than the minimum reset pulse width to reset the I ² C bus and all internal registers to their POR values.
6	6	A1	I ² C Slave Address Input. Connect A1 to GND, V _{DD} , SDA, or SCL to set the desired I ² C bus address. Do not leave unconnected (Table 1). High impedance for supply voltages from 0 to 3.7V.
7	7	A0	I ² C Slave Address Input. Connect A0 to GND, V _{DD} , SDA, or SCL to set the desired I ² C bus address. Do not leave unconnected (Table 1). High impedance for supply voltages from 0 to 3.7V.
8	8	V _{DD}	Positive Supply Voltage Input. Bypass to GND with a 0.1μF bypass capacitor.
—	—	EP	Exposed Pad (Bottom Side of Package). Connect EP to GND.

MAX31725/MAX31726

±0.5°C Local Temperature Sensors

Block Diagram

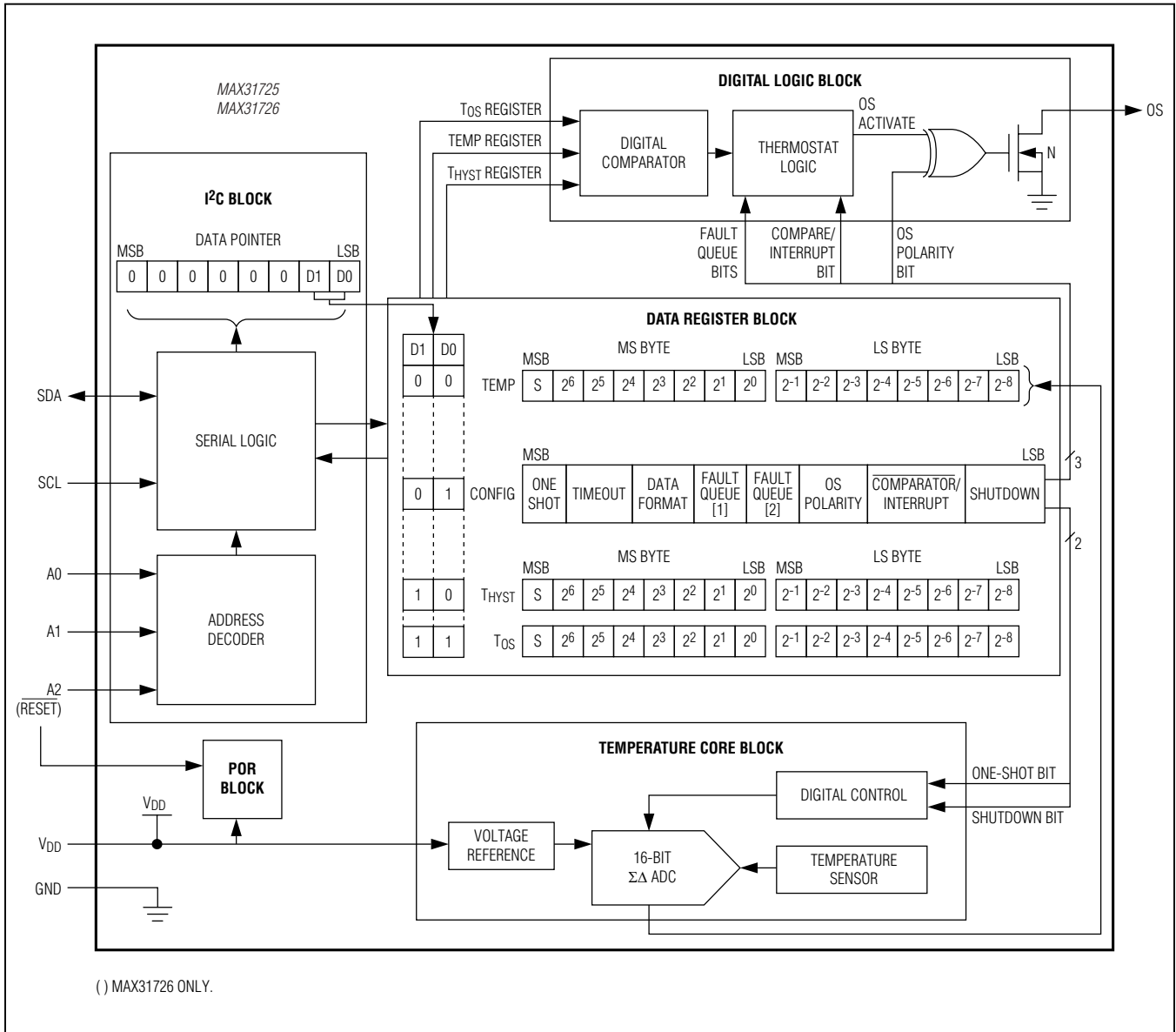

MAX31725/MAX31726

±0.5°C Local Temperature Sensors

Detailed Description

The MAX31725/MAX31726 temperature sensors measure temperature and convert the data into digital form. An I²C-compatible two-wire serial interface allows access to conversion results. The devices accept standard I²C commands to read the data, set the overtemperature alarm (OS) trip thresholds, and configure other characteristics. While reading the temperature register, any changes in temperature are ignored until the read is completed. The temperature register is updated for the new temperature measurement upon completion of the read operation.

OS Output, T_{OS} and T_{HYST} Limits

In comparator mode, the OS output behaves like a thermostat (Figure 2). The output asserts when the temperature rises above the limit set in the T_{OS} register. The output deasserts when the temperature falls below the limit set in the T_{HYST} register. In comparator mode, the OS output can be used to turn on a cooling fan, initiate an emergency shutdown signal, or reduce system clock speed.

In interrupt mode, exceeding T_{OS} also asserts OS. OS remains asserted until a read operation is performed on any of the registers. Once OS has asserted due to

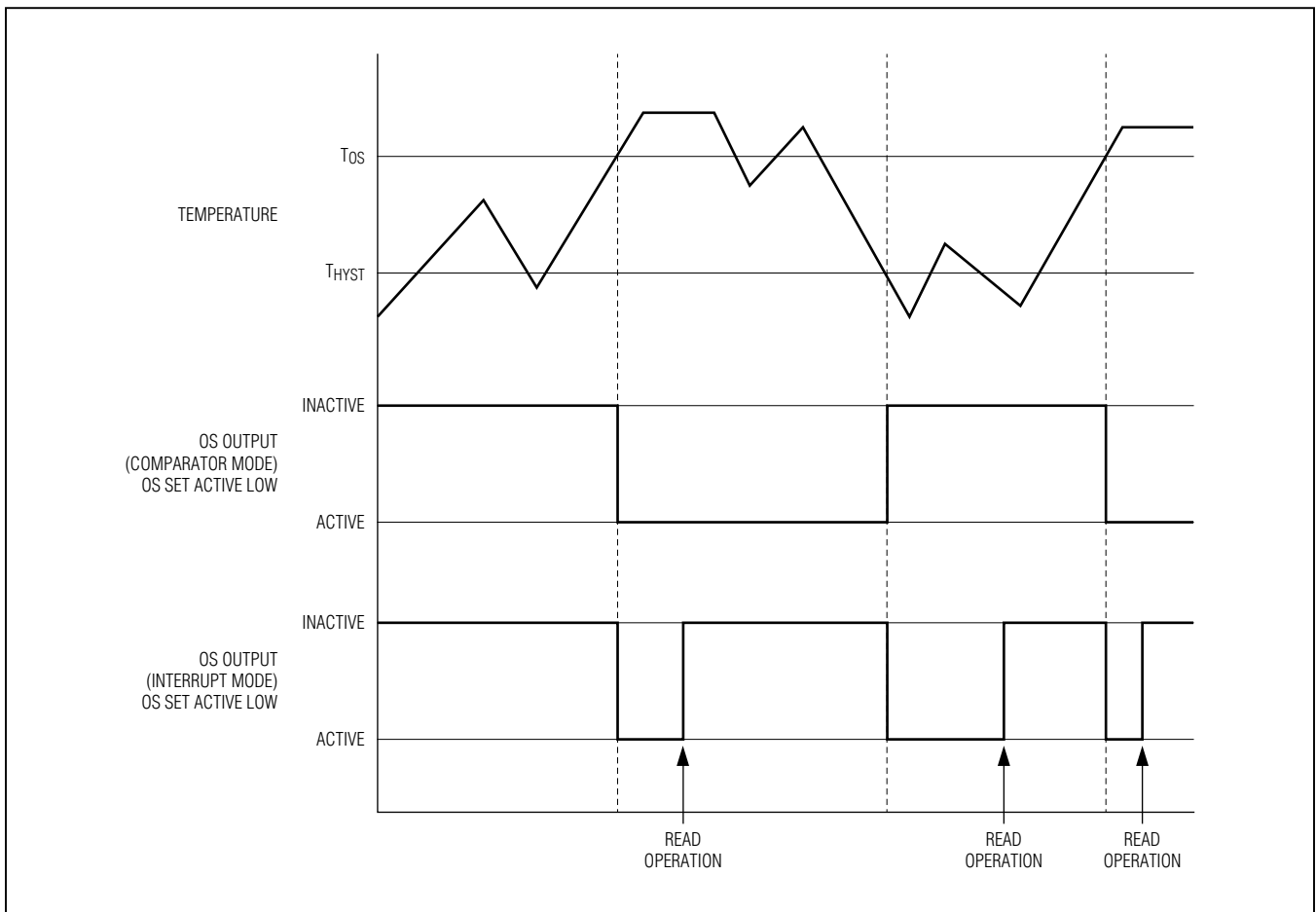

Figure 2. OS Output Temperature Response Diagram

MAX31725/MAX31726

±0.5°C Local Temperature Sensors

Table 1a. MAX31725 Slave Address Selection

A2 CONNECTION	A1 CONNECTION	A0 CONNECTION	SLAVE ADDRESS BYTE (hex)
GND	GND	GND	90h
GND	GND	V _{DD}	92h
GND	GND	SCL	82h
GND	GND	SDA	80h
GND	V _{DD}	GND	94h
GND	V _{DD}	V _{DD}	96h
GND	V _{DD}	SCL	86h
GND	V _{DD}	SDA	84h
GND	SCL	GND	B4h
GND	SCL	V _{DD}	B6h
GND	SCL	SCL	A6h
GND	SCL	SDA	A4h
GND	SDA	GND	B0h
GND	SDA	V _{DD}	B2h
GND	SDA	SCL	A2h
GND	SDA	SDA	A0h
V _{DD}	GND	GND	98h
V _{DD}	GND	V _{DD}	9Ah
V _{DD}	GND	SCL	8Ah
V _{DD}	GND	SDA	88h
V _{DD}	V _{DD}	GND	9Ch
V _{DD}	V _{DD}	V _{DD}	9Eh
V _{DD}	V _{DD}	SCL	8Eh
V _{DD}	V _{DD}	SDA	8Ch
V _{DD}	SCL	GND	BCh
V _{DD}	SCL	V _{DD}	BEh
V _{DD}	SCL	SCL	AEh
V _{DD}	SCL	SDA	ACh
V _{DD}	SDA	GND	B8h
V _{DD}	SDA	V _{DD}	BAh
V _{DD}	SDA	SCL	AAh
V _{DD}	SDA	SDA	A8h

crossing above T_{OS} and is then reset, it is asserted again only when the temperature drops below T_{HYST}. The output then remains asserted until it is reset by a read. It is then asserted again if the temperature rises above T_{OS}, and so on. Putting the MAX31725 or MAX31726 into shutdown mode also resets OS.

I²C-Compatible Bus Interface

A standard I²C-compatible 2-wire serial interface reads temperature data from the temperature registers and reads and writes control bits and alarm threshold data to and from the alarm and configuration registers.

Each device responds to its own I²C slave address, which is selected using the A0, A1, and A2 pins for the MAX31725 or the A0 and A1 pins for the MAX31726. A0 and A1 can be connected to the supply voltage, ground, SDA, or SCL. A2 can be connected to supply voltage or ground to provide up to 32 unique addresses for the MAX31725 and up to 16 unique addresses for the MAX31726.

Table 1a and Table 1b show how the A0, A1, and A2 connections determine the slave address.

Table 1b. MAX31726 Slave Address Selection

A1 CONNECTION	A0 CONNECTION	SLAVE ADDRESS BYTE (hex)
GND	GND	98h
GND	V _{DD}	9Ah
GND	SCL	8Ah
GND	SDA	88h
V _{DD}	GND	9Ch
V _{DD}	V _{DD}	9Eh
V _{DD}	SCL	8Eh
V _{DD}	SDA	8Ch
SCL	GND	BCh
SCL	V _{DD}	BEh
SCL	SCL	AEh
SCL	SDA	ACh
SDA	GND	B8h
SDA	V _{DD}	BAh
SDA	SCL	AAh
SDA	SDA	A8h

MAX31725/MAX31726

±0.5°C Local Temperature Sensors

Internal Registers

The device contains four registers, each of which consists of 2 bytes. The configuration register contains only 1 byte of actual data and, when read as a 2-byte register, repeats the same data for the second byte. During a 2-byte write to the configuration register the second byte written takes precedence. The device's pointer register selects between the four data registers shown in [Table 2](#). During reads and writes the pointer register auto increments after every 2 data bytes, but does not wrap from address 03h–00h. The pointer register must

be written for each I²C transaction. All registers are read and write, except for the read-only temperature register.

Write to the configuration register by writing the slave address byte, the pointer register byte to value 01h, and a data byte. The T_{OS} and T_{HYST} registers require the slave address byte, pointer register byte, and 2 data bytes. If only 1 data byte is written, it is saved in bits D[15:8] of the respective register. If more than 2 data bytes are written, the pointer register auto increments and if pointing to a valid address, additional data writes to the next address. See [Figure 3](#).

Table 2. Register Functions and POR State

REGISTER NAME	ADDRESS (Hex)	POR STATE		POR STATE (°C)	READ/ WRITE
		Hex	BINARY		
Temperature	00	0000h	0000 0000 0000 0000	0	Read-only
Configuration MAX31725	01	00h	0000 0000	—	R/W
Configuration MAX31726	01	40h	0100 0000	—	R/W
T _{HYST}	02	4B00h	0100 1011 0000 0000	75	R/W
T _{OS}	03	5000h	0101 0000 0000 0000	80	R/W

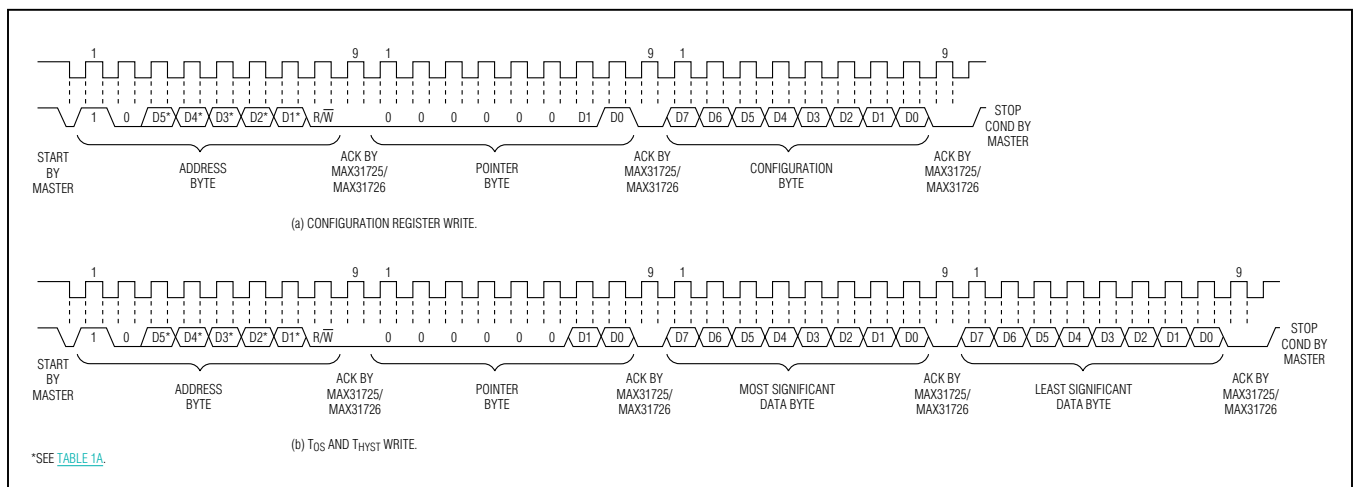

Figure 3. I²C-Compatible Timing Diagram (Write)

MAX31725/MAX31726

±0.5°C Local Temperature Sensors

Perform a read operation by issuing the slave address byte (write), pointer byte, repeat START, another slave address byte (read), and then reading the data byte. After 2 data bytes the pointer register auto increments and, if pointing to a valid address, additional data can be read. See [Figure 4](#).

Temperature Registers

Temperature data is stored in the temperature, T_{OS} set point, and T_{HYST} set point registers. The temperature data format is 16 bits, two's complement, and the register is read out in 2 bytes: an upper byte and a lower byte.

Bits D[15:0] contains the temperature data, with the LSB representing 0.00390625°C and the MSB representing the sign bit; see [Table 3](#). The MSB is transmitted first.

In addition to the normal two's complement temperature data format, the MAX31725 and MAX31726 offer an optional extended data format that allows temperatures equal to or greater than +128°C to be read. In the extended format, selected by bit 5 of the configuration register, the measured temperature is the value in the temperature register plus 64°C, as shown in [Table 4](#).

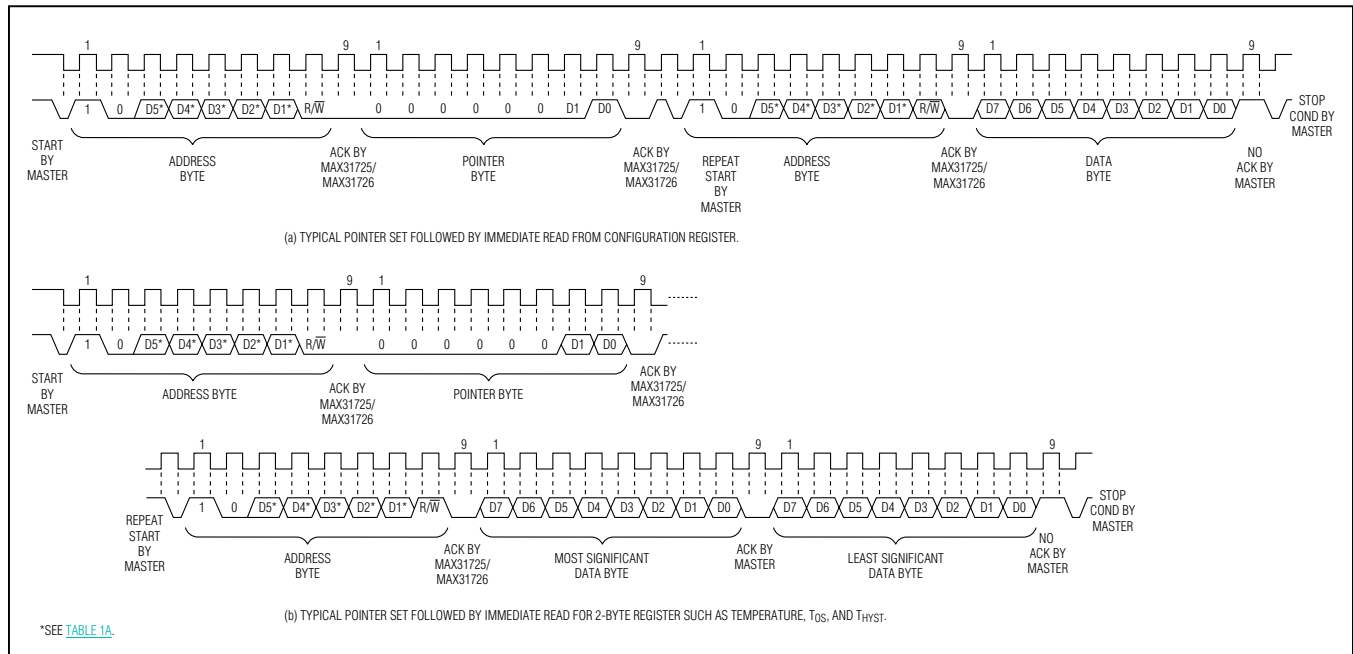

Figure 4. I²C-Compatible Timing Diagram (Read)

Table 3. Temperature, T_{HYST} , and T_{OS} Register Definition

UPPER BYTE								LOWER BYTE							
D15	D14	D13	D12	D11	D10	D9	D8	D7	D6	D5	D4	D3	D2	D1	D0
S	MSB 64°C	32°C	16°C	8°C	4°C	2°C	1°C	0.5°C	0.25°C	0.125°C	0.0625°C	0.03125°C	0.015625°C	0.0078125°C	0.00390625°C
	2 ⁶	2 ⁵	2 ⁴	2 ³	2 ²	2 ¹	2 ⁰	2 ⁻¹	2 ⁻²	2 ⁻³	2 ⁻⁴	2 ⁻⁵	2 ⁻⁶	2 ⁻⁷	2 ⁻⁸

MAX31725/MAX31726

±0.5°C Local Temperature Sensors

Table 4. Temperature Data Output Format

TEMPERATURE (°C)	NORMAL FORMAT		EXTENDED FORMAT	
	BINARY	Hex	BINARY	Hex
+150	0111 1111 1111 1111	7FFFh	0101 0110 0000 0000	5600h
+128	0111 1111 1111 1111	7FFFh	0100 0000 0000 0000	4000h
+127	0111 1111 0000 0000	7F00h	0011 1111 0000 0000	3F00h
+125	0111 1101 0000 0000	7D00h	0011 1101 0000 0000	3D00h
+64	0100 0000 0000 0000	4000h	0000 0000 0000 0000	0000h
+25	0001 1001 0000 0000	1900h	1101 1001 0000 0000	D900h
+0.5	0000 0000 1000 0000	0080h	1100 0000 1000 0000	C080h
0	0000 0000 0000 0000	0000h	1100 0000 0000 0000	C000h
-0.5	1111 1111 1000 0000	FF80h	1011 1111 1000 0000	BF80h
-25	1110 0111 0000 0000	E700h	1010 0111 0000 0000	A700h
-55	1100 1001 0000 0000	C900h	1000 1001 0000 0000	8900h

Table 5. Configuration Register Definition

D7	D6	D5	D4	D3	D2	D1	D0
ONE-SHOT	TIMEOUT	DATA FORMAT	FAULT QUEUE [1]	FAULT QUEUE [0]	OS POLARITY	COMPARATOR/ INTERRUPT	SHUTDOWN

Configuration Register

The configuration register contains 8 bits of data and initiates single conversions (ONE-SHOT), enables bus timeout, controls shutdown, sets the fault queue, sets the data format, selects OS polarity, and determines whether the OS output functions in comparator or interrupt mode. See [Table 5](#).

Shutdown

Set bit D0 to 1 to place the device in shutdown mode and reduce supply current to 3.5µA or less. If bit D0 is set to 1 when a temperature conversion is taking place, the device completes the conversion and then shuts down. In interrupt mode, entering shutdown resets the OS output. While in shutdown, the I²C interface remains active and all registers remain accessible to the master.

Setting D0 to 0 takes the device out of shutdown and starts a new conversion. The results of this conversion are available to read after the max conversion time.

COMPARATOR/INTERRUPT Mode

Set bit D1, the COMPARATOR/INTERRUPT bit to 0 to operate OS in comparator mode. In comparator mode, OS is asserted when the temperature rises above the T_{OS} value. OS is deasserted when the temperature drops below the T_{HYST} value. See [Figure 2](#).

Set bit D1 to 1 to operate OS in interrupt mode. In interrupt mode, exceeding T_{OS} also asserts OS. OS remains asserted until a read operation is performed on any of the registers. Once OS has asserted due to crossing above T_{OS} and is then reset, it is asserted again only when the temperature drops below T_{HYST}. The output then remains asserted until it is reset by a read. It is then asserted again if the temperature rises above T_{OS}, and so on. Putting the MAX31725 into shutdown mode also resets OS. Note that if the mode is changed while OS is active, an OS reset may be required before it begins to behave normally.

OS Polarity

Set bit D2, the OS POLARITY bit, to 0 to force the OS output polarity to active low. Set bit D2 to 1 to set the OS output polarity to active high. OS is an open-drain output under all conditions and requires a pullup resistor to output a high voltage. See [Figure 2](#).

Fault Queue

Bits D4 and D3, the fault queue bits, determine the number of faults necessary to trigger an OS condition. See [Table 6](#). The number of faults set in the queue must occur consecutively to trip the OS output. The fault queue prevents OS false tripping in noisy environments.

MAX31725/MAX31726

±0.5°C Local Temperature Sensors

Table 6. Configuration Register Fault Queue Bits

FAULT QUEUE [1] BIT D4	FAULT QUEUE [0] BIT D3	NUMBER OF FAULTS
0	0	1 (POR state)
0	1	2
1	0	4
1	1	6

Data Format

Bit D5 selects the temperature data format for the temperature, T_{OS} , and T_{HYST} registers. When D5 is 0 (normal format), the data format is two's complement with a range of -128°C to $+127.99609375^{\circ}\text{C}$.

Set D5 to 1 for extended temperature format. In extended format, the measured temperature equals the two's complement value plus 64°C , thereby extending the upper temperature data range to $191.99609375^{\circ}\text{C}$ and allowing temperatures as high as 150°C to be measured. See [Table 4](#). Once set, the data format does not update until the completion of the following temperature conversion. After setting D5 to 1, new extended temperature data is guaranteed ready after a time equal to twice the max conversion time.

TIMEOUT Enable

Set D6 to 1 to disable bus timeout.

Set D6 to 0 to reset the I²C-compatible interface when SDA is low for more than 50ms (nominal).

One-Shot

The ONE-SHOT function helps to reduce average supply current when continuous conversions are not necessary. Setting D7 to 1 while the device is in shutdown mode immediately begins a new temperature conversion. After the conversion has completed, the device returns to shutdown mode. D7 returns to 0 when the conversion completes. Writing 1 to D7 has no effect when the device is not in shutdown.

Power-On Reset Value

The configuration register always powers up to a known state, as indicated in [Table 2](#). These default POR values correspond to the following modes of operation:

- Comparator mode
- OS active low
- 1 fault, fault queue

- Normal data format
- Timeout enabled for MAX31725; timeout disabled for MAX31726

RESET Input (MAX31726 Only)

The $\overline{\text{RESET}}$ input on the MAX31726 provides a way to reset the I²C bus and all the internal registers to their initial POR values. To reset, apply a low pulse width a duration of at least the minimum reset pulse width (t_{RESET}) to the $\overline{\text{RESET}}$ input.

Applications Information

The MAX31725 and MAX31726 measure the temperature of their own die. The thermal path between the die and the outside world determines the accuracy of temperature measurements. External temperature is conducted to the die primarily through the leads and the exposed pad. Because of this, the device most easily measures the PCB temperature. For ambient temperature measurements, mount the device on a PCB (or a section of the PCB) that is at ambient temperature. Temperature errors due to self-heating of the device die are minimal due to the low supply current.

Digital Noise Issues

Both devices feature an integrated lowpass filter on the SCL and SDA digital lines to mitigate the effects of bus noise. Although this filtering makes communication robust in noisy environments, good layout practices are always recommended. Minimize noise coupling by keeping digital traces away from switching power supplies. Ensure that digital lines containing high-speed data cross at right angles to the SDA and SCL lines. Excessive noise coupling into the SDA and SCL lines on the device—specifically noise with amplitude greater than $400\text{mV}_{\text{P-P}}$ (typical hysteresis), overshoot greater than 300mV above $+V_{\text{DD}}$, and undershoot more than 300mV below GND—can prevent successful serial communication. Serial bus not-acknowledge is the most common symptom, causing unnecessary traffic on the bus. Care must be taken to ensure proper termination within a system with long PCB traces or multiple slaves on the bus. Resistance can be added in series with the SDA and SCL lines to further help filter noise and ringing. If it proves to be necessary, a $5\text{k}\Omega$ resistor should be placed in series with the SCL line, placed as close as possible to the SCL pin. This $5\text{k}\Omega$ resistor, with the 5pF to 10pF stray capacitance of the device provide a 6MHz to 12MHz lowpass filter, which is sufficient filtering in most cases.

MAX31725/MAX31726

±0.5°C Local Temperature Sensors

Ordering Information

PART	TEMP RANGE	RESET	TIMEOUT ENABLED AT POR	PIN-PACKAGE
MAX31725MTA+	-55°C to +150°C	No	Yes	8 TDFN-EP*
MAX31726MTA+	-55°C to +150°C	Yes	No	8 TDFN-EP*

+Denotes a lead(Pb)-free/RoHS-compliant package.

*EP = Exposed pad.

Package Information

For the latest package outline information and land patterns (footprints), go to www.maximintegrated.com/packages. Note that a "+", "#", or "-" in the package code indicates RoHS status only. Package drawings may show a different suffix character, but the drawing pertains to the package regardless of RoHS status.

PACKAGE TYPE	PACKAGE CODE	OUTLINE NO.	LAND PATTERN NO.
8 TDFN-EP	T833+2	21-0137	90-0059

MAX31725/MAX31726

±0.5°C Local Temperature Sensors

Revision History

REVISION NUMBER	REVISION DATE	DESCRIPTION	PAGES CHANGED
0	9/12	Initial release	—
1	3/13	Added the MAX31726	All
2	12/14	Updated <i>Benefits and Features</i> section	1



Maxim Integrated cannot assume responsibility for use of any circuitry other than circuitry entirely embodied in a Maxim Integrated product. No circuit patent licenses are implied. Maxim Integrated reserves the right to change the circuitry and specifications without notice at any time. The parametric values (min and max limits) shown in the Electrical Characteristics table are guaranteed. Other parametric values quoted in this data sheet are provided for guidance.

Maxim Integrated 160 Rio Robles, San Jose, CA 95134 USA 1-408-601-1000

15