



Chipsmall Limited consists of a professional team with an average of over 10 year of expertise in the distribution of electronic components. Based in Hongkong, we have already established firm and mutual-benefit business relationships with customers from,Europe,America and south Asia,supplying obsolete and hard-to-find components to meet their specific needs.

With the principle of "Quality Parts,Customers Priority,Honest Operation,and Considerate Service",our business mainly focus on the distribution of electronic components. Line cards we deal with include Microchip,ALPS,ROHM,Xilinx,Pulse,ON,Everlight and Freescale. Main products comprise IC,Modules,Potentiometer,IC Socket,Relay,Connector.Our parts cover such applications as commercial,industrial, and automotives areas.

We are looking forward to setting up business relationship with you and hope to provide you with the best service and solution. Let us make a better world for our industry!



Contact us

Tel: +86-755-8981 8866 Fax: +86-755-8427 6832

Email & Skype: info@chipsmall.com Web: www.chipsmall.com

Address: A1208, Overseas Decoration Building, #122 Zhenhua RD., Futian, Shenzhen, China





±15kV ESD-Protected, EMC-Compliant, 230kbps RS-232 Serial Port for Modems

MAX3186

General Description

The MAX3186 is a complete DCE RS-232 serial port designed to meet the stringent ESD requirements of the European community. All transmitter outputs and receiver inputs are protected to ±15kV using IEC 1000-4-2 Air-Gap Discharge, ±8kV using IEC 1000-4-2 Contact Discharge, and ±15kV using the Human Body Model.

The MAX3186 has five RS-232 transmitters, three RS-232 receivers, and no charge pump, optimizing it for operation in modem applications. It is guaranteed to run at data rates up to 230kbps, providing compatibility with popular software for communicating with personal computers. Power-supply current is less than 300µA for I_{DD} and I_{SS}, and less than 1mA for I_{CC}.

The MAX3186 is available in an SO package and in the tiny SSOP that further reduces board space.

Features

- ◆ Enhanced ESD Protection:
 - ±15kV—Human Body Model
 - ±8kV—IEC1000-4-2, Contact Discharge
 - ±15kV—IEC1000-4-2, Air-Gap Discharge
- ◆ Latchup Free During an ESD Event
- ◆ 20-Pin SSOP or SO Packages
- ◆ Guaranteed 230kbps Data Rate
- ◆ Flow-Through Pinout
- ◆ Complete DCE Serial Port

Applications

- Modems
- ISDN Modems
- Instruments
- Equipment Meeting IEC1000-4-2

Ordering Information

PART	TEMP. RANGE	PIN-PACKAGE
MAX3186CWP	0°C to +70°C	20 SO
MAX3186CAP	0°C to +70°C	20 SSOP
MAX3186EWP	-40°C to +85°C	20 SO
MAX3186EAP	-40°C to +85°C	20 SSOP

Typical Operating Circuit

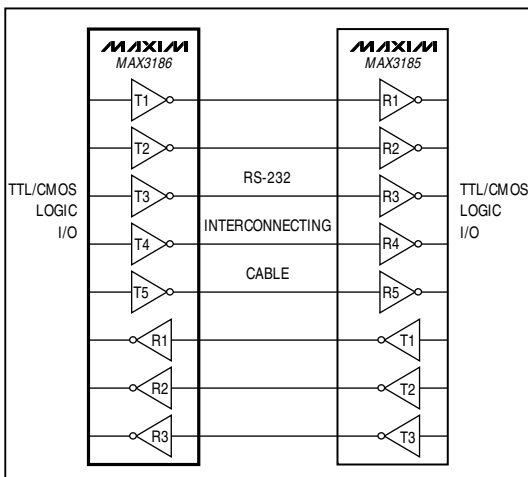

Pin Configuration

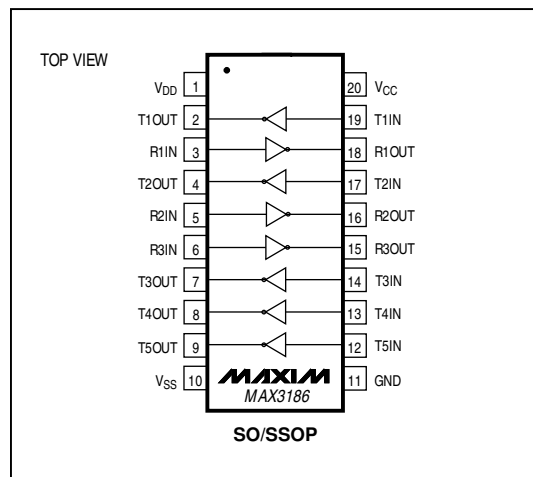

±15kV ESD-Protected, EMC-Compliant, 230kbps RS-232 Serial Port for Modems

ABSOLUTE MAXIMUM RATINGS

VCC	-0.3V to +7V	Continuous Power Dissipation (T _A = +70°C)	
VDD	-0.3V to +14V	Wide SO (derate 10.00mW/°C above +70°C).....	800mW
VSS	+0.3V to -14V	SSOP (derate 8.00mW/°C above +70°C)	640mW
Input Voltages			
T _{IN}	-0.3V to +6V	Operating Temperature Ranges	
R _{IN}	±30V	MAX3186C_P	0°C to +70°C
Output Voltages			
T _{OUT}	±15V	MAX3186E_P	-40°C to +85°C
R _{OUT}	-0.3V to (V _{CC} + 0.3V)	Storage Temperature Range	-65°C to +160°C
Short-Circuit Duration			
T _{OUT} (one at a time)	Continuous	Lead Temperature (soldering, 10sec)	+300°C
R _{OUT} (one at a time)	Continuous		

Stresses beyond those listed under "Absolute Maximum Ratings" may cause permanent damage to the device. These are stress ratings only, and functional operation of the device at these or any other conditions beyond those indicated in the operational sections of the specifications is not implied. Exposure to absolute maximum rating conditions for extended periods may affect device reliability.

ELECTRICAL CHARACTERISTICS

(V_{CC} = +4.5V to +5.5V, V_{DD} = +10.8V to +13.2V, V_{SS} = -10.8V to -13.2V, T_A = T_{MIN} to T_{MAX}, unless otherwise noted. Typical values are at T_A = +25°C.)

PARAMETER	SYMBOL	CONDITIONS	MIN	TYP	MAX	UNITS
DC CHARACTERISTICS						
Operating Voltage Range	V _{CC}		4.5		5.5	V
	V _{DD}		10.8		13.2	
	V _{SS}		-13.2		-10.8	
Supply Current	I _{CC}	No load		230	1000	µA
	I _{DD}	No load		280	750	
	I _{SS}	No load		280	750	
LOGIC						
Input Logic Threshold Low	V _{ILT}	T _{IN}			0.8	V
Input Logic Threshold High	V _{IHT}	T _{IN}	2.0			V
Input Leakage Current				0.01	1	µA
Output Voltage Low	V _{OLR}	R _{OUT} ; I _{SINK} = 3.2mA			0.4	V
Output Voltage High	V _{OHR}	R _{OUT} ; I _{SOURCE} = 1mA	V _{CC} - 0.6			V
TRANSMITTER OUTPUTS						
Output Voltage Swing		V _{DD} = 7.0V, V _{SS} = -7.0V, R _L = 3kΩ	±5.0			V
		V _{DD} = 12V, V _{SS} = -12V, R _L = 3kΩ	±9.5			
Transmitter Output Resistance		V _{CC} = V _{DD} = V _{SS} = 0V, V _{T_OUT} = ±2V	300			Ω
RS-232 Output Short-Circuit Current				±35	±60	mA
RECEIVER INPUTS						
Receiver Input Voltage Operating Range			-25		25	V
RS-232 Input Threshold Low			0.75			V
RS-232 Input Threshold High					2.4	V
RS-232 Input Hysteresis				0.65		V
RS-232 Input Resistance			3	5	7	kΩ
Receiver Output Short-Circuit Current				±10		mA

±15kV ESD-Protected, EMC-Compliant, 230kbps RS-232 Serial Port for Modems

MAX3186

ELECTRICAL CHARACTERISTICS (continued)

(V_{CC} = +4.5V to +5.5V, V_{DD} = +10.8V to +13.2V, V_{SS} = -10.8V to -13.2V, T_A = T_{MIN} to T_{MAX}, unless otherwise noted. Typical values are at T_A = +25°C.)

PARAMETER	SYMBOL	CONDITIONS	MIN	TYP	MAX	UNITS
ESD CHARACTERISTICS						
ESD Protection		Human Body Model		±15		kV
		IEC1000-4-2 (Contact Discharge)		±8		
		IEC1000-4-2 (Air-Gap Discharge)		±15		
TIMING CHARACTERISTICS						
Transmitter Output Propagation Delay, Low to High	t _{PLHT}	V _{DD} = 12V, V _{SS} = -12V, R _L = 3kΩ, C _L = 1000pF, T _A = +25°C			4	μs
Transmitter Output Propagation Delay, High to Low	t _{PHLT}	V _{DD} = 12V, V _{SS} = -12V, R _L = 3kΩ, C _L = 1000pF, T _A = +25°C			4	μs
Transmitter Propagation Delay Skew, t _{PLHT} - t _{PHLT}	t _{SKT}	V _{DD} = 12V, V _{SS} = -12V, R _L = 3kΩ, C _L = 1000pF, T _A = +25°C			0.4	μs
Transition Output Slew Rate	SR	V _{DD} = 12V, V _{SS} = -12V, R _L = 3kΩ to 7kΩ, measured from +3V to -3V or -3V to +3V, Figure 3, T _A = +25°C	C _L = 150pF to 2500pF	4	30	V/μs
			C _L = 50pF to 1000pF	8	30	
Receiver Output Propagation Delay, Low to High	t _{PLHR}	V _{CC} = 5V, C _L = 50pF, T _A = +25°C			4.0	μs
Receiver Output Propagation Delay, High to Low	t _{PHLR}	V _{CC} = 5V, C _L = 50pF, T _A = +25°C			4.0	μs
Receiver Propagation Delay Skew, t _{PLHR} - t _{PHLR}	t _{SKR}	V _{CC} = 5V, C _L = 50pF, T _A = +25°C			0.4	μs
Guaranteed Data Rate	DR	V _{CC} = 5V, V _{DD} = 12V, V _{SS} = -12V, R _L = 3kΩ to 7kΩ, T _A = +25°C	C _L = 50pF to 2500pF	120		kbps
			C _L = 50pF to 1000pF	230		

±15kV ESD-Protected, EMC-Compliant, 230kbps RS-232 Serial Port for Modems

Typical Operating Characteristics

(VCC = +5.0V, VDD = +12.0V, VSS = -12.0V, TA = +25°C, unless otherwise noted.)

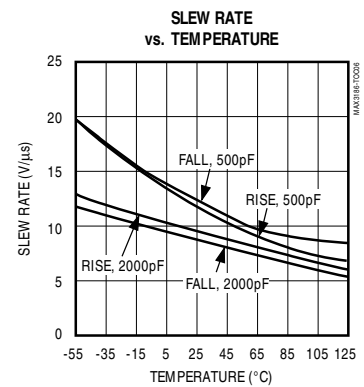
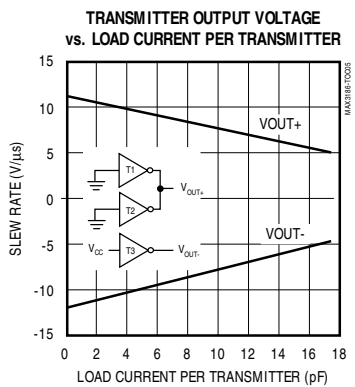
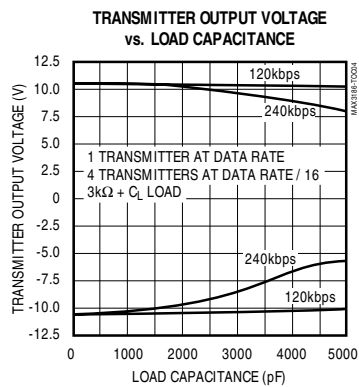
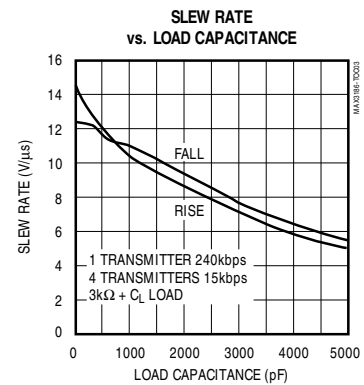
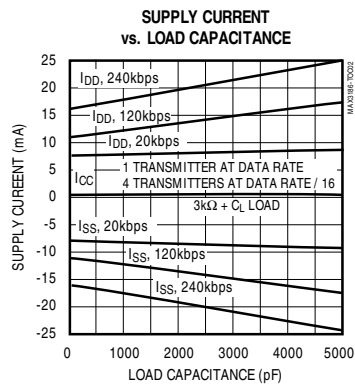
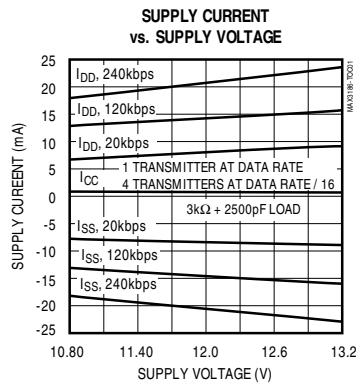

±15kV ESD-Protected, EMC-Compliant, 230kbps RS-232 Serial Port for Modems

MAX3186

Pin Description

PIN	NAME	FUNCTION
1	V _{DD}	Supply-Voltage Input, +10.8V to +13.2V
2, 4, 7, 8, 9	T1OUT-T5OUT	Transmitter Outputs, swing between V _{DD} and V _{SS}
3, 5, 6	R1IN, R2IN, R3IN	Receiver Inputs
10	V _{SS}	Supply-Voltage Input, -10.8V to -13.2V
11	GND	Ground. Connect to system ground.
12, 13, 14, 17, 19	T5IN-T1IN	Transmitter Inputs
15, 16, 18	R3OUT, R2OUT, R1OUT	Receiver Outputs, swing between GND and V _{CC}
20	V _{CC}	Supply-Voltage Input, +4.5V to +5.5V

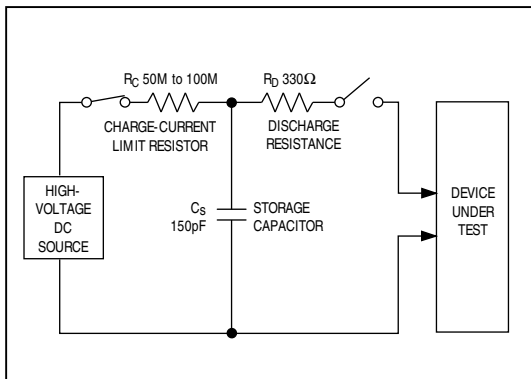

Figure 1a. IEC1000-4-2 ESD Test Model

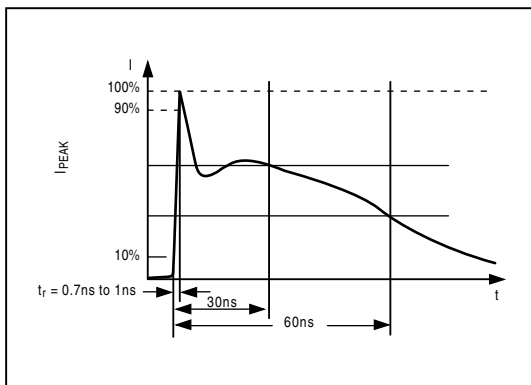

Figure 1b. IEC1000-4-2 ESD Generator Current Waveform

Detailed Description

±15kV ESD Protection

As with all Maxim devices, ESD-protection structures are incorporated on all pins to protect against electrostatic discharges encountered during handling and assembly. The MAX3186 driver outputs and receiver inputs have extra protection against static electricity found in normal operation. Maxim's engineers developed state-of-the-art structures to protect these pins against ESD of ±15kV, without damage. After an ESD event, the MAX3186 continues working without latchup.

ESD protection can be tested in several ways. The transmitter outputs and the receiver inputs are characterized for protection to the following:

- 1) ±15kV using the Human Body Model
- 2) ±8kV using the Contact-Discharge Method specified in IEC1000-4-2 (formerly IEC801-2)
- 3) ±15kV using the Air-Gap Method specified in IEC1000-4-2 (formerly IEC801-2)

ESD Test Conditions

ESD performance depends on a number of conditions. Contact Maxim for a reliability report that documents test setup, methodology, and results.

±15kV ESD-Protected, EMC-Compliant, 230kbps RS-232 Serial Port for Modems

Human Body Model

Figure 2a shows the Human Body Model, and Figure 2b shows the current waveform it generates when discharged into a low impedance. This model consists of a 100pF capacitor charged to the ESD voltage of interest, which is then discharged into the device through a 1.5kΩ resistor.

IEC1000-4-2

The IEC1000-4-2 standard covers ESD testing and performance of finished equipment; it does not specifically refer to integrated circuits. The MAX3186 helps you design equipment that meets Level 4 (the highest level) of IEC1000-4-2, without additional ESD-protection components.

The main difference between tests done using the Human Body Model and IEC1000-4-2 is higher peak current in IEC1000-4-2. Because series resistance is lower in the IEC1000-4-2 ESD test model (Figure 1a), the ESD withstand voltage measured to this standard is generally lower than measured using the Human Body Model. Figure 1b shows the current waveform for the ±8kV IEC1000-4-2 Level 4 ESD Contact-Discharge test.

The Air-Gap test involves approaching the device with a charge probe. The Contact-Discharge method connects the probe to the device before the probe is energized.

Machine Model

The Machine Model for ESD testing uses a 200pF storage capacitor and zero-discharge resistance. It mimics the stress caused by handling during manufacturing and assembly. Of course, all pins (not just RS-232 inputs and outputs) require this protection during manufacturing. Therefore, the Machine Model is less relevant to the I/O ports than are the Human Body Model and IEC1000-4-2.

Applications Information

Use proper layout to ensure other devices on your board are not damaged in an ESD strike. Currents as high as 60A can instantaneously pass into the ground, so be sure to minimize the ground-lead return path to the power supply. A separate return path to the power supply is recommended. Trace widths should be greater than 40 mils. Bypass V_{CC} , V_{DD} , and V_{SS} with 0.1μF capacitors as close to the part as possible to ensure maximum ESD protection.

Tie any transmitter inputs to GND or V_{CC} . No external protection diodes are needed because the MAX3186 is not sensitive to power-supply sequencing.

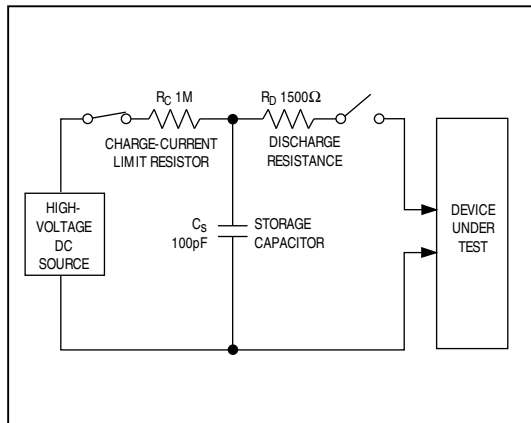

Figure 2a. Human Body ESD Test Model

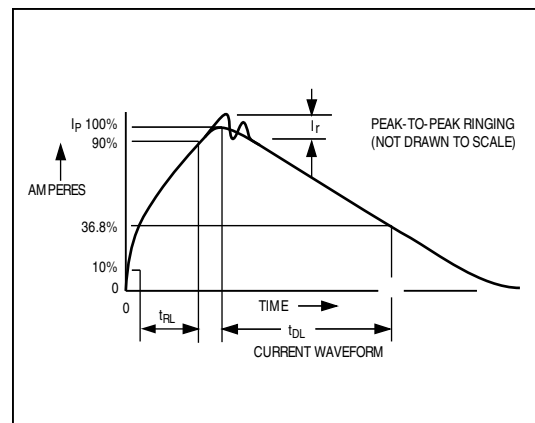

Figure 2b. Human Body Model Current Waveform

±15kV ESD-Protected, EMC-Compliant, 230kbps RS-232 Serial Port for Modems

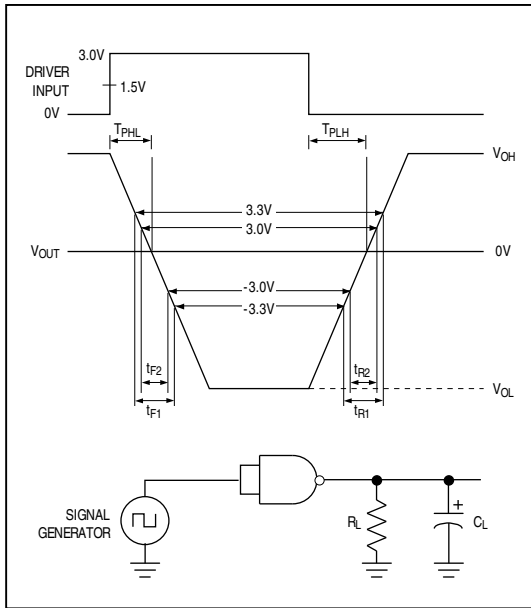
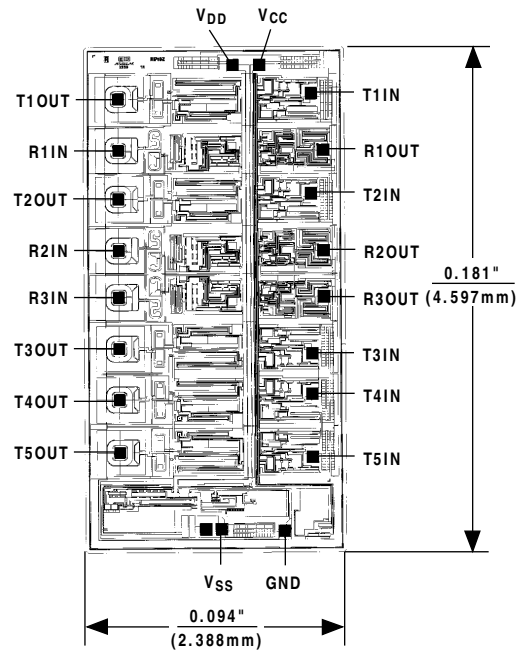

Figure 3. Slew-Rate Test Circuit and Timing Diagram

Chip Topography



MAX3186

TRANSISTOR COUNT: 195
SUBSTRATE CONNECTED TO GND

MAX3186

±15kV ESD-Protected, EMC-Compliant, 230kbps RS-232 Serial Port for Modems

Package Information

**Wide SO
SMALL-OUTLINE
PACKAGE
(0.300 in.)**

DIM	INCHES		MILLIMETERS	
	MIN	MAX	MIN	MAX
A	0.093	0.104	2.35	2.65
A1	0.004	0.012	0.10	0.30
B	0.014	0.019	0.35	0.49
C	0.009	0.013	0.23	0.32
E	0.291	0.299	7.40	7.60
e	0.050		1.27	
H	0.394	0.419	10.00	10.65
L	0.016	0.050	0.40	1.27

DIM	PINS	INCHES		MILLIMETERS	
		MIN	MAX	MIN	MAX
D	16	0.398	0.413	10.10	10.50
D	18	0.447	0.463	11.35	11.75
D	20	0.496	0.512	12.60	13.00
D	24	0.598	0.614	15.20	15.60
D	28	0.697	0.713	17.70	18.10

21-0042A

**SSOP
SHRINK
SMALL-OUTLINE
PACKAGE**

DIM	INCHES		MILLIMETERS	
	MIN	MAX	MIN	MAX
A	0.068	0.078	1.73	1.99
A1	0.002	0.008	0.05	0.21
B	0.010	0.015	0.25	0.38
C	0.004	0.008	0.09	0.20
D	SEE VARIATIONS			
E	0.205	0.209	5.20	5.38
e	0.0256 BSC		0.65 BSC	
H	0.301	0.311	7.65	7.90
L	0.025	0.037	0.63	0.95
α	0°	8°	0°	8°

DIM	PINS	INCHES		MILLIMETERS	
		MIN	MAX	MIN	MAX
D	14	0.239	0.249	6.07	6.33
D	16	0.239	0.249	6.07	6.33
D	20	0.278	0.289	7.07	7.33
D	24	0.317	0.328	8.07	8.33
D	28	0.397	0.407	10.07	10.33

21-0056A

Maxim cannot assume responsibility for use of any circuitry other than circuitry entirely embodied in a Maxim product. No circuit patent licenses are implied. Maxim reserves the right to change the circuitry and specifications without notice at any time.

8 Maxim Integrated Products, 120 San Gabriel Drive, Sunnyvale, CA 94086 (408) 737-7600

© 1996 Maxim Integrated Products

Printed USA

MAXIM is a registered trademark of Maxim Integrated Products.