



Chipsmall Limited consists of a professional team with an average of over 10 year of expertise in the distribution of electronic components. Based in Hongkong, we have already established firm and mutual-benefit business relationships with customers from,Europe,America and south Asia,supplying obsolete and hard-to-find components to meet their specific needs.

With the principle of “Quality Parts,Customers Priority,Honest Operation,and Considerate Service”,our business mainly focus on the distribution of electronic components. Line cards we deal with include Microchip,ALPS,ROHM,Xilinx,Pulse,ON,Everlight and Freescale. Main products comprise IC,Modules,Potentiometer,IC Socket,Relay,Connector.Our parts cover such applications as commercial,industrial, and automotives areas.

We are looking forward to setting up business relationship with you and hope to provide you with the best service and solution. Let us make a better world for our industry!



## Contact us

Tel: +86-755-8981 8866 Fax: +86-755-8427 6832

Email & Skype: info@chipsmall.com Web: www.chipsmall.com

Address: A1208, Overseas Decoration Building, #122 Zhenhua RD., Futian, Shenzhen, China





# Precision, CMOS Analog Switches

MAX317/MAX318/MAX319

## General Description

The MAX317/MAX318/MAX319 are precision, CMOS, monolithic analog switches. The single-pole single-throw (SPST) MAX317 is normally closed (NC), the SPST MAX318 is normally open (NO), and the single-pole double-throw (SPDT) MAX319 has one normally open and one normally closed switch. All three parts offer low on resistance (less than 35Ω), guaranteed to match within 2Ω between channels and to remain flat over the analog signal range (Δ3Ω max). They also offer low leakage (less than 250pA at +25°C and less than 6nA at +85°C) and fast switching (turn-on time less than 175ns and turn-off time less than 145ns).

The MAX317/MAX318/MAX319 are fabricated with Maxim's new improved silicon-gate process. Design improvements guarantee extremely low charge injection (10pC), low power consumption (35μW), and electrostatic discharge (ESD) greater than ±2000V. The 44V maximum breakdown voltage allows rail-to-rail analog signal handling capability.

## Applications

- Sample-and-Hold Circuits
- Guidance and Control Systems
- Heads-Up Displays
- Test Equipment
- Military Radios
- Communications Systems
- Battery-Powered Systems
- PBX, PABX

## Features

- ♦ Low On Resistance <20Ω Typical (35Ω Max)
- ♦ Guaranteed Matched On Resistance Between Channels <2Ω
- ♦ Guaranteed Flat On Resistance over Analog Signal Range Δ3Ω Max
- ♦ Guaranteed Charge Injection <10pC
- ♦ Guaranteed Off-Channel Leakage <6nA at +85°C
- ♦ ESD Guaranteed > 2000V per Method 3015.7
- ♦ Single-Supply Operation (+10V to +30V)  
Bipolar-Supply Operation (±4.5V to ±20V)
- ♦ TTL-/CMOS-Logic Compatible
- ♦ Rail-to-Rail Analog Signal Handling Capability

## Ordering Information

PART	TEMP. RANGE	PIN-PACKAGE
MAX317CPA	0°C to +70°C	8 Plastic DIP
MAX317CSA	0°C to +70°C	8 SO
MAX317CJA	0°C to +70°C	8 CERDIP
MAX317C/D	0°C to +70°C	Dice*
MAX317EPA	-40°C to +85°C	8 Plastic DIP
MAX317ESA	-40°C to +85°C	8 SO
MAX317EJA	-40°C to +85°C	8 CERDIP
MAX317MJA	-55°C to +125°C	8 CERDIP

Ordering Information continued on last page.

\* Contact factory for dice specifications.

## Pin Configurations/Functional Diagrams/Truth Tables

TOP VIEW

**DIP/SO**

MAX317	
LOGIC	SWITCH
0	ON
1	OFF

**DIP/SO**

MAX318	
LOGIC	SWITCH
0	OFF
1	ON

**DIP/SO**

MAX319		
LOGIC	NC	NO
0	ON	OFF
1	OFF	ON

N.C. = No Connect  
NC = Normally Closed

SWITCHES SHOWN FOR LOGIC "0" INPUT



# Precision, CMOS Analog Switches

## ABSOLUTE MAXIMUM RATINGS

Voltage Referenced to V-

V+	.....+44V
GND	.....+25V
V <sub>L</sub>	.....(GND - 0.3V) to (V+ + 0.3V)
I <sub>N</sub> , COM, NC, NO	.....(V- - 2V) to (V+ + 2V) or 30mA, whichever occurs first
Continuous Current (any terminal)	.....30mA
Peak Current, NC, NO, COM	.....30mA
Peak Current, NC, NO, COM (pulsed at 1ms, 10% duty cycle max)	.....100mA
ESD	.....±2000V

Continuous Power Dissipation (T<sub>A</sub> = +70°C) (Note 1)

Plastic DIP (derate 9.09mW/°C above +70°C)	.....727mW
SO (derate 5.88mW/°C above +70°C)	.....471mW
CERDIP (derate 8.00mW/°C above +70°C)	.....640mW
Operating Temperature Ranges:	
MAX31_C	.....0°C to +70°C
MAX31_E	.....-40°C to +85°C
MAX31_MJA	.....-55°C to +125°C
Storage Temperature Range	.....-55°C to +150°C
Lead Temperature (soldering, 10sec)	.....+300°C

**Note 1:** All leads are soldered or welded to PC board.

Stresses beyond those listed under "Absolute Maximum Ratings" may cause permanent damage to the device. These are stress ratings only, and functional operation of the device at these or any other conditions beyond those indicated in the operational sections of the specifications is not implied. Exposure to absolute maximum rating conditions for extended periods may affect device reliability.

## ELECTRICAL CHARACTERISTICS — Dual Supplies

(V+ = 15V, V- = -15V, V<sub>L</sub> = 5V, GND = 0V, V<sub>INL</sub> = 0.8V, V<sub>INH</sub> = 2.4V, T<sub>A</sub> = T<sub>MIN</sub> to T<sub>MAX</sub>, unless otherwise noted.)

PARAMETER	SYMBOL	CONDITIONS	TEMP.	MIN	TYP (Note 2)	MAX	UNITS	
Analog-Signal Range	V <sub>COM</sub> , V <sub>NO</sub> , V <sub>NC</sub>	(Note 3)		-15		15	V	
On Resistance	R <sub>ON</sub>	V <sub>COM</sub> = ±12.5V, I <sub>(NC OR NO)</sub> = -10mA, V+ = 13.5V, V- = -13.5V	T <sub>A</sub> = +25°C		20	35	Ω	
				C, E				30
			T <sub>A</sub> = T <sub>MIN</sub> to T <sub>MAX</sub>			45		
On Resistance Match Between Channels (Note 4)	R <sub>ON</sub>	I <sub>(NC OR NO)</sub> = -10mA, V <sub>COM</sub> = 10V or -10V, V+ = 15V, V- = -15V	T <sub>A</sub> = +25°C			2	Ω	
			T <sub>A</sub> = T <sub>MIN</sub> to T <sub>MAX</sub>					3
On Resistance Flatness (Note 4)	R <sub>ON</sub>	I <sub>(NC OR NO)</sub> = -10mA, V <sub>COM</sub> = 5V or -5V, V+ = 15V, V- = -15V	T <sub>A</sub> = +25°C			3	Ω	
			T <sub>A</sub> = T <sub>MIN</sub> to T <sub>MAX</sub>					5
NO or NC Off Leakage Current	I <sub>NC(OFF)</sub> or I <sub>NO(OFF)</sub>	V+ = 16.5V, V- = -16.5V, V <sub>COM</sub> = ±15.5V, V <sub>NC</sub> or V <sub>NO</sub> = ±15.5V	T <sub>A</sub> = +25°C	-0.25		0.25	nA	
				C, E	-6			6
				M	-20			20
COM Off Leakage Current	I <sub>COM(OFF)</sub>	V+ = 16.5V, V- = -16.5V, V <sub>COM</sub> = ±15.5V, V <sub>NC</sub> or V <sub>NO</sub> = ±15.5V	T <sub>A</sub> = +25°C	-0.25	-0.1	0.25	nA	
				C, E	-6			6
				M	-20			20
			T <sub>A</sub> = +25°C	-0.75	-0.1	0.75		
				C, E	-10			10
				M	-60			60
COM On Leakage Current	I <sub>COM(ON)</sub>	V+ = 16.5V, V- = -16.5V, V <sub>NC</sub> or V <sub>NO</sub> = V <sub>D</sub> = ±15.5V	T <sub>A</sub> = +25°C	-0.4		0.4	nA	
				C, E	-10			10
				M	-40			40
			T <sub>A</sub> = +25°C	-0.75		0.75		
				C, E	-10			10
				M	-60			60

# Precision, CMOS Analog Switches

MAX317/MAX318/MAX319

## ELECTRICAL CHARACTERISTICS — Dual Supplies (continued)

(V<sub>+</sub> = 15V, V<sub>-</sub> = -15V, V<sub>L</sub> = 5V, GND = 0V, V<sub>INL</sub> = 0.8V, V<sub>INH</sub> = 2.4V, T<sub>A</sub> = T<sub>MIN</sub> to T<sub>MAX</sub>, unless otherwise noted.)

PARAMETER	SYMBOL	CONDITIONS	TEMP.	MIN	TYP (Note 2)	MAX	UNITS
<b>LOGIC INPUT</b>							
Logic Input Current (Input Voltage High)	I <sub>IH</sub>	V <sub>IN</sub> = 2.4V		-0.5	0.005	0.5	μA
Logic Input Current (Input Voltage Low)	I <sub>IL</sub>	V <sub>IN</sub> = 0.8V		-0.5	0.005	0.5	μA
<b>DYNAMIC</b>							
Turn-On Time	t <sub>ON</sub>	MAX317, MAX318, Figure 2, V <sub>COM</sub> = ±10V	T <sub>A</sub> = +25°C	100	175	ns	
			T <sub>A</sub> = T <sub>MIN</sub> to T <sub>MAX</sub>		250		
Turn-Off Time	t <sub>OFF</sub>	MAX317, MAX318, Figure 2, V <sub>COM</sub> = ±10V	T <sub>A</sub> = +25°C	60	145	ns	
			T <sub>A</sub> = T <sub>MIN</sub> to T <sub>MAX</sub>		210		
Transition Time	t <sub>TRANS</sub>	MAX319, Figure 3, V <sub>NO</sub> = ±10V, V <sub>NC</sub> = ±10V	T <sub>A</sub> = +25°C		175	ns	
			T <sub>A</sub> = T <sub>MIN</sub> to T <sub>MAX</sub>		250		
Break-Before-Make Interval	t <sub>D</sub>	MAX319, Figure 4, V <sub>NO</sub> = V <sub>NC</sub> = ±10V	T <sub>A</sub> = +25°C	5	13	ns	
Charge Injection	Q	V <sub>GEN</sub> = 0V, Figure 5	T <sub>A</sub> = +25°C		3	10	pC
Off Isolation (Note 5)	OIRR	R <sub>L</sub> = 50Ω, C <sub>L</sub> = 5pF, f = 1MHz, Figure 7	T <sub>A</sub> = +25°C		68		dB
Crosstalk (Note 6)		R <sub>L</sub> = 50Ω, C <sub>L</sub> = 5pF, f = 1MHz, Figure 8	T <sub>A</sub> = +25°C		85		dB
COM Off Capacitance	C <sub>COM(OFF)</sub>	V <sub>COM</sub> = 0V, f = 1MHz, Figure 8	T <sub>A</sub> = +25°C		8		pF
Off Capacitance NC or NO	C <sub>(OFF)</sub>	V <sub>COM</sub> = 0V, f = 1MHz, Figure 8	T <sub>A</sub> = +25°C		8		pF
Channel-On Capacitance COM Terminal	C <sub>COM(ON)</sub>	V <sub>S</sub> = 0V, f = 1MHz, Figure 9	MAX317, MAX318 MAX319	T <sub>A</sub> = +25°C	30	pF	
					35		
<b>SUPPLY</b>							
Positive Supply Current	I <sub>+</sub>	V <sub>IN</sub> = 0V or 5V, V <sub>+</sub> = 16.5V, V <sub>-</sub> = -16.5V	T <sub>A</sub> = +25°C	-1	0.0001	1	μA
			T <sub>A</sub> = T <sub>MIN</sub> to T <sub>MAX</sub>	-5		5	
Negative Supply Current	I <sub>-</sub>	V <sub>IN</sub> = 0V or 5V, V <sub>+</sub> = 16.5V, V <sub>-</sub> = -16.5V	T <sub>A</sub> = +25°C	-1	-0.0001	1	μA
			T <sub>A</sub> = T <sub>MIN</sub> to T <sub>MAX</sub>	-5		5	
Logic Supply Current	I <sub>L</sub>	V <sub>IN</sub> = 0V or 5V, V <sub>+</sub> = 16.5V, V <sub>-</sub> = -16.5V	T <sub>A</sub> = +25°C	-1	0.0001	1	μA
			T <sub>A</sub> = T <sub>MIN</sub> to T <sub>MAX</sub>	-5		5	
Ground Current	I <sub>GND</sub>	V <sub>IN</sub> = 0V or 5V, V <sub>+</sub> = 16.5V, V <sub>-</sub> = -16.5V	T <sub>A</sub> = +25°C	-1	-0.0001	1	μA
			T <sub>A</sub> = T <sub>MIN</sub> to T <sub>MAX</sub>	-5		5	

# Precision, CMOS Analog Switches

MAX317/MAX318/MAX319

## ELECTRICAL CHARACTERISTICS — Single Supply

(V<sub>+</sub> = 12V, V<sub>-</sub> = 0V, V<sub>L</sub> = 5V, GND = 0V, V<sub>INH</sub> = 2.4V, V<sub>INL</sub> = 0.8V, T<sub>A</sub> = +25°C, unless otherwise noted.)

PARAMETER	SYMBOL	CONDITIONS	MIN	TYP (Note 2)	MAX	UNITS
<b>SWITCH</b>						
Analog-Signal Range	V <sub>COM</sub> , V <sub>NO</sub> , V <sub>NC</sub>	(Note 3)	0		12	V
Drain-Source On Resistance	R <sub>(ON)</sub>	I <sub>(NC or NO)</sub> = -10mA, V <sub>COM</sub> = 3.8V, V <sub>+</sub> = 10.8V		40	100	Ω
<b>DYNAMIC</b>						
Turn-On Time	t <sub>ON</sub>	V <sub>COM</sub> = 8V, Figure 2		110		ns
Turn-Off Time	t <sub>OFF</sub>	V <sub>COM</sub> = 8V, Figure 2		40		ns
Break-Before-Make Time Delay	t <sub>D</sub>	MAX319, R <sub>L</sub> = 1000Ω, C <sub>L</sub> = 35pF, Figure 4		60		ns
Charge Injection	Q	C <sub>L</sub> = 10nF, V <sub>GEN</sub> = 0V, R <sub>GEN</sub> = 0V, Figure 5		2	10	pC
<b>SUPPLY</b>						
Positive Supply Current	I <sub>+</sub>	V <sub>+</sub> = 13.2V, all channels on or off, V <sub>IN</sub> = 0V or 5V, V <sub>L</sub> = 5.25V		0.0001		μA
Negative Supply Current	I <sub>-</sub>	V <sub>+</sub> = 13.2V, all channels on or off, V <sub>IN</sub> = 0V or 5V, V <sub>L</sub> = 5.25V		0.0001		μA
Logic Supply Current	I <sub>L</sub>	V <sub>L</sub> = 5.25V, all channels on or off, V <sub>IN</sub> = 0V or 5V		0.0001		μA
Ground Current	I <sub>GND</sub>	V <sub>L</sub> = 5.25V, all channels on or off, V <sub>IN</sub> = 0V or 5V		-0.0001		μA

**Note 2:** Typical values are for **design aid only**, not guaranteed, not subject to production testing.

**Note 3:** Guaranteed by design.

**Note 4:** On resistance match between channels and flatness are guaranteed only with bipolar-supply operation.

**Note 5:** Off Isolation =  $20\log_{10} \left( \frac{V_{COM}}{V_{NC} \text{ or } V_{NO}} \right)$ , V<sub>COM</sub> = output, V<sub>NC</sub> or V<sub>NO</sub> = input to off switch.

**Note 6:** Between any two switches.

# Precision, CMOS Analog Switches

## Typical Operating Characteristics

( $T_A = +25^\circ\text{C}$ , unless otherwise noted).

MAX317/MAX318/MAX319

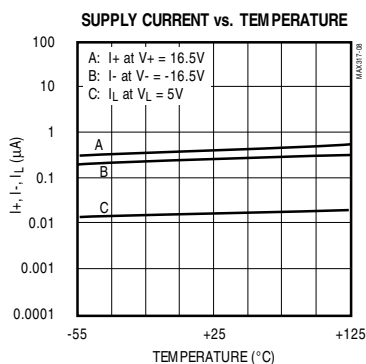
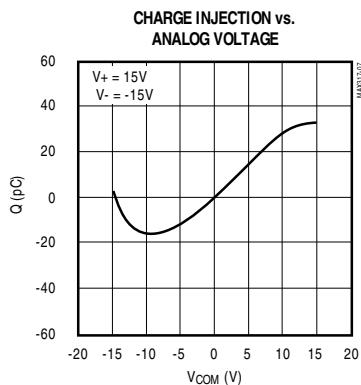
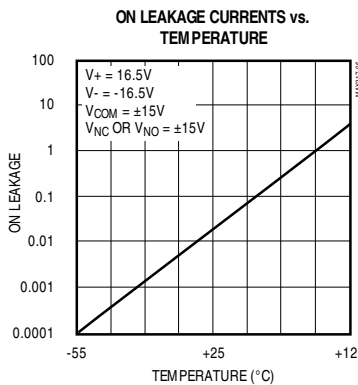
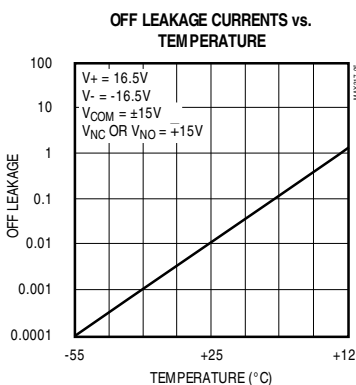
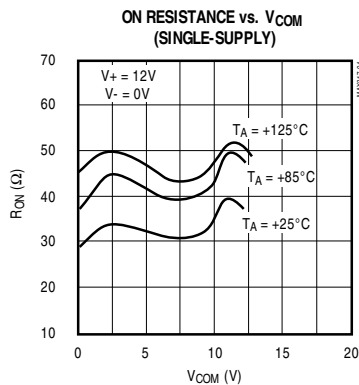
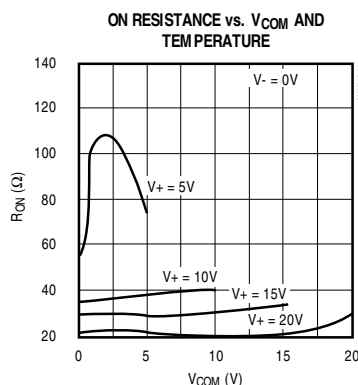
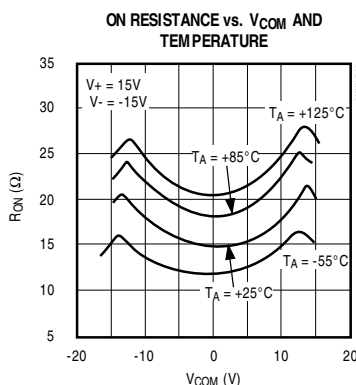
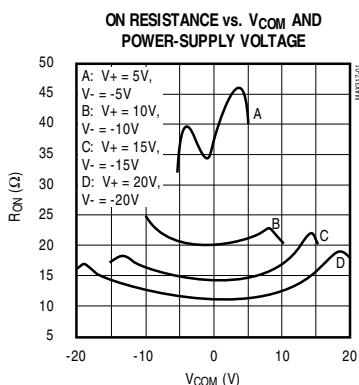

# Precision, CMOS Analog Switches

## Pin Description

PIN			NAME	FUNCTION
MAX317	MAX318	MAX319		
1	1	1	COM	Analog-switch common terminal
2	2	—	N.C.	No connect — not internally connected
—	—	8	NO	Analog-switch normally open terminal
3	3	3	GND	Logic ground
4	4	4	V+	Analog-signal positive supply input
5	5	5	VL	Logic-level positive supply input
6	6	6	IN	Logic-level input
7	7	7	V-	Analog-signal negative supply input
8	—	2	NC	Analog-switch normally closed terminal
—	8	—	NO	Analog-switch normally open terminal

## Applications Information

### Operation with Supply Voltages Other Than $\pm 15V$

The main limitation of supply voltages other than  $\pm 15V$  is analog signal range reduction. The MAX317/MAX318/MAX319 switches operate with bipolar supplies of  $\pm 5V$  to  $\pm 20V$ . Typical Operating Characteristics graphs show typical on resistance for  $\pm 15V$ ,  $\pm 10V$ , and  $\pm 5V$  supplies. Switching times increase by a factor of two or more for operation at  $\pm 5V$ . The MAX317/MAX318/MAX319 can operate from unipolar supplies of  $+10V$  to  $+30V$ . Both parts can also operate from unbalanced supplies such as  $+24V$  and  $-5V$ .

Connect V- to 0V when operating with a single supply. This means that VL must be connected to  $+5V$  to be TTL compatible, or to V+ for CMOS logic input levels.

### Overvoltage Protection

Proper power-supply sequencing is recommended for all CMOS devices. It is important not to exceed the absolute maximum ratings because stresses beyond the listed ratings may cause permanent damage to the devices. Always sequence V+ on first, followed by VL, V-, and logic inputs. If power-supply sequencing is not possible, protect the devices from overvoltage by

adding two small signal diodes in series with the supply pins (Figure 1). Adding the diodes reduces the analog signal range to 1V below V+ and 1V below V-, but low switch resistance and low leakage characteristics are unaffected. Device operation is unchanged, and the difference between V+ to V- should not exceed  $+44V$ .

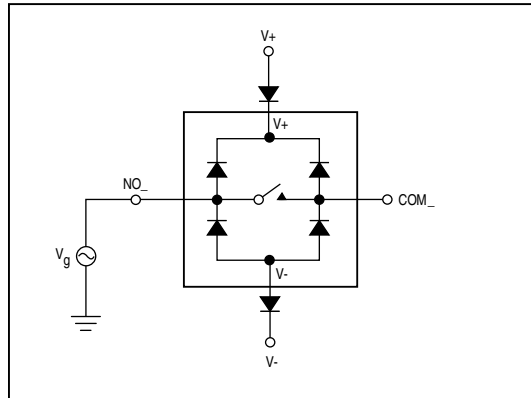

Figure 1. Overvoltage Protection Using Blocking Diodes

# Precision, CMOS Analog Switches

## Test Circuits/Timing Diagrams

MAX317/MAX318/MAX319

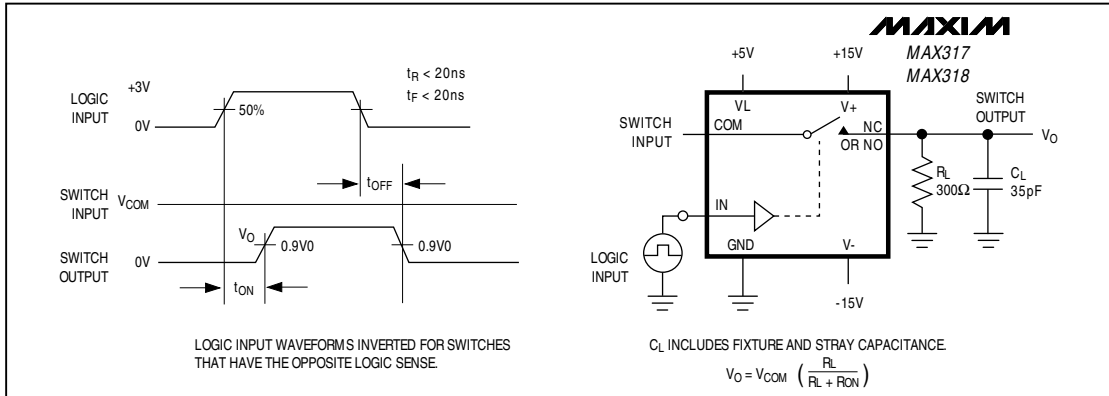

Figure 2. MAX317/MAX318 Switching-Time Test Circuit

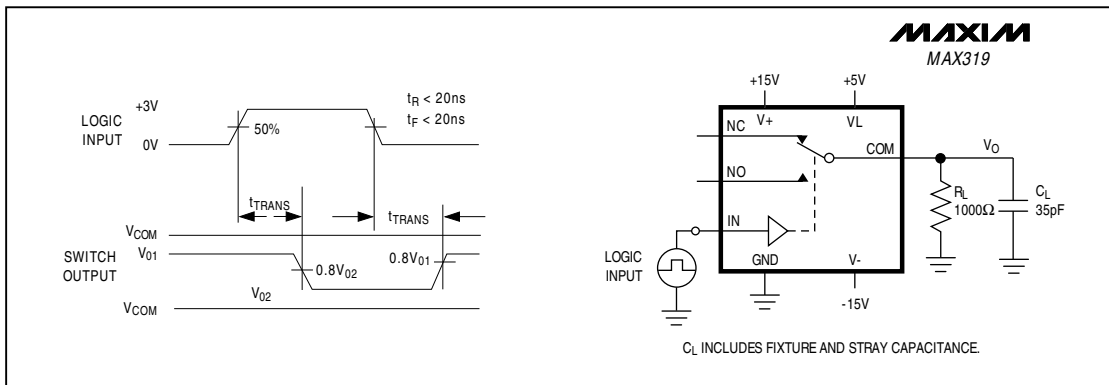

Figure 3. MAX319 Transition Time



# Precision, CMOS Analog Switches

## Test Circuits/Timing Diagrams (continued)

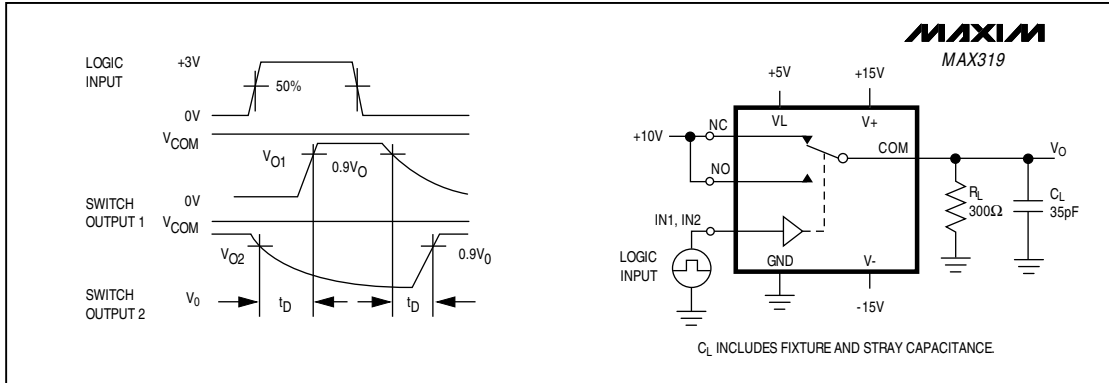

Figure 4. MAX319 Break-Before-Make Test Circuit

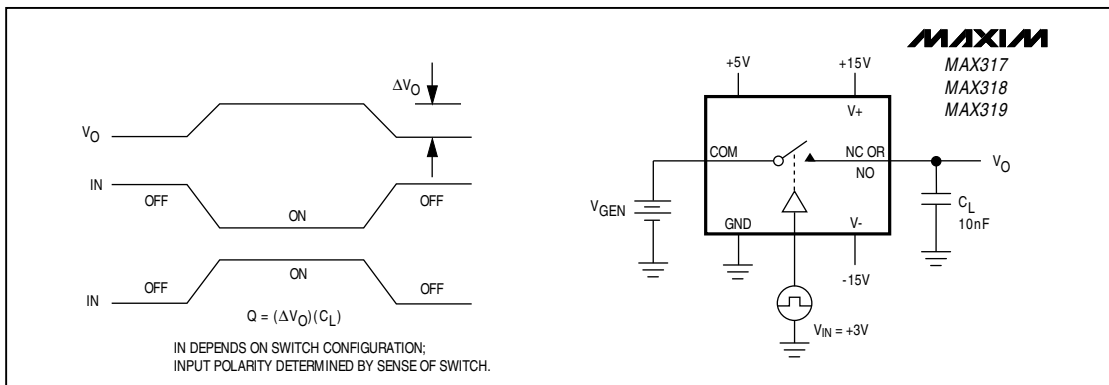

Figure 5. Charge-Injection Test Circuit

# Precision, CMOS Analog Switches

## Test Circuits/Timing Diagrams (continued)

MAX317/MAX318/MAX319

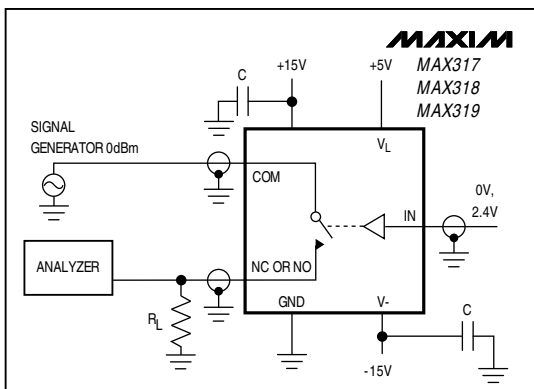

Figure 6. Off-Isolation Test Circuit

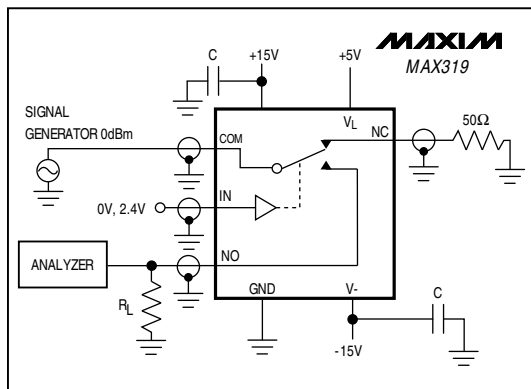

Figure 7. MAX319 Crosstalk Test Circuit

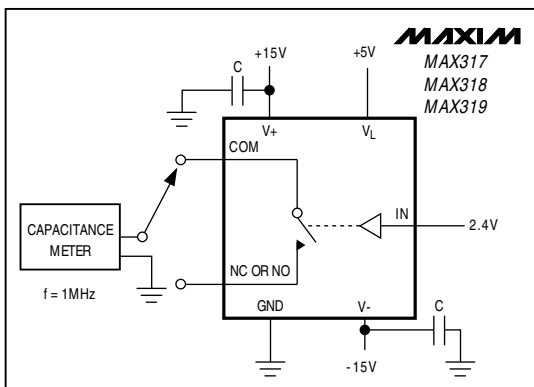

Figure 8. Channel-Off Capacitance Test Circuit

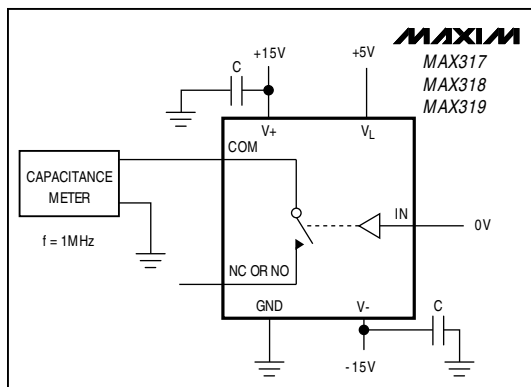

Figure 9. Channel-On Capacitance Test Circuit

# Precision, CMOS Analog Switches

**MAX317/MAX318/MAX319**

## Ordering Information (continued)

PART	TEMP. RANGE	PIN-PACKAGE
MAX318CPA	0°C to +70°C	8 Plastic DIP
MAX318CSA	0°C to +70°C	8 SO
MAX318CJA	0°C to +70°C	8 CERDIP
MAX318C/D	0°C to +70°C	Dice*
MAX318EPA	-40°C to +85°C	8 Plastic DIP
MAX318ESA	-40°C to +85°C	8 SO
MAX318 EJA	-40°C to +85°C	8 CERDIP
MAX318MJA	-55°C to +125°C	8 CERDIP**
MAX319CPA	0°C to +70°C	8 Plastic DIP
MAX319CSA	0°C to +70°C	8 SO
MAX319CJA	0°C to +70°C	8 CERDIP
MAX319C/D	0°C to +70°C	Dice*
MAX319EPA	-40°C to +85°C	8 Plastic DIP
MAX319ESA	-40°C to +85°C	8 SO
MAX319EJA	-40°C to +85°C	8 CERDIP
MAX319MJA	-55°C to +125°C	8 CERDIP**

\* Contact factory for dice specifications.

\*\* Contact factory for availability and processing to MIL-STD-883.

## Chip Topography

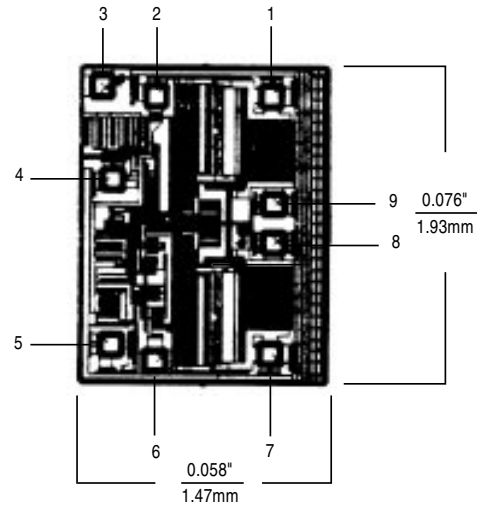

TRANSISTOR COUNT: 32;

SUBSTRATE CONNECTED TO V+.

DIE PAD	MAX317	MAX318	MAX319
1	COM	NC	NC
2	GND	GND	GND
3	V+	V+	V+
4	VL	VL	VL
5	IN	IN	IN
6	V-	V-	V-
7	N.C.	NO	NO
8	N.C.	COM	COM
9	NC	NC	COM

# Precision, CMOS Analog Switches

## Package Information

MAX317/MAX318/MAX319

**Plastic DIP  
PLASTIC  
DUAL-IN-LINE  
PACKAGE  
(0.300 in.)**

DIM	INCHES		MILLIMETERS	
	MIN	MAX	MIN	MAX
A	—	0.200	—	5.08
A1	0.015	—	0.38	—
A2	0.125	0.175	3.18	4.45
A3	0.055	0.080	1.40	2.03
B	0.016	0.022	0.41	0.56
B1	0.045	0.065	1.14	1.65
C	0.008	0.012	0.20	0.30
D1	0.005	0.080	0.13	2.03
E	0.300	0.325	7.62	8.26
E1	0.240	0.310	6.10	7.87
e	0.100	—	2.54	—
eA	0.300	—	7.62	—
eB	—	0.400	—	10.16
L	0.115	0.150	2.92	3.81

PKG.	DIM	PINS	INCHES		MILLIMETERS	
			MIN	MAX	MIN	MAX
P	D	8	0.348	0.390	8.84	9.91
P	D	14	0.735	0.765	18.67	19.43
P	D	16	0.745	0.765	18.92	19.43
P	D	18	0.885	0.915	22.48	23.24
P	D	20	1.015	1.045	25.78	26.54
N	D	24	1.14	1.265	28.96	32.13

21-0043A

**Narrow SO  
SMALL-OUTLINE  
PACKAGE  
(0.150 in.)**

DIM	INCHES		MILLIMETERS	
	MIN	MAX	MIN	MAX
A	0.053	0.069	1.35	1.75
A1	0.004	0.010	0.10	0.25
B	0.014	0.019	0.35	0.49
C	0.007	0.010	0.19	0.25
E	0.150	0.157	3.80	4.00
e	0.050		1.27	
H	0.228	0.244	5.80	6.20
L	0.016	0.050	0.40	1.27

DIM	PINS	INCHES		MILLIMETERS	
		MIN	MAX	MIN	MAX
D	8	0.189	0.197	4.80	5.00
D	14	0.337	0.344	8.55	8.75
D	16	0.386	0.394	9.80	10.00

21-0041A

# Precision, CMOS Analog Switches

## Package Information

**CERDIP  
CERAMIC DUAL-IN-LINE  
PACKAGE  
(0.300 in.)**

DIM	INCHES		MILLIMETERS	
	MIN	MAX	MIN	MAX
A	—	0.200	—	5.08
B	0.014	0.023	0.36	0.58
B1	0.038	0.065	0.97	1.65
C	0.008	0.015	0.20	0.38
E	0.220	0.310	5.59	7.87
E1	0.290	0.320	7.37	8.13
e	0.100		2.54	
L	0.125	0.200	3.18	5.08
L1	0.150	—	3.81	—
Q	0.015	0.070	0.38	1.78
S	—	0.098	—	2.49
S1	0.005	—	0.13	—

DIM	PINS	INCHES		MILLIMETERS	
		MIN	MAX	MIN	MAX
D	8	—	0.405	—	10.29
D	14	—	0.785	—	19.94
D	16	—	0.840	—	21.34
D	18	—	0.960	—	24.38
D	20	—	1.060	—	26.92
D	24	—	1.280	—	32.51

21-0045A

Maxim cannot assume responsibility for use of any circuitry other than circuitry entirely embodied in a Maxim product. No circuit patent licenses are implied. Maxim reserves the right to change the circuitry and specifications without notice at any time.

12 \_\_\_\_\_ Maxim Integrated Products, 120 San Gabriel Drive, Sunnyvale, CA 94086 (408) 737-7600