



Chipsmall Limited consists of a professional team with an average of over 10 year of expertise in the distribution of electronic components. Based in Hongkong, we have already established firm and mutual-benefit business relationships with customers from,Europe,America and south Asia,supplying obsolete and hard-to-find components to meet their specific needs.

With the principle of “Quality Parts,Customers Priority,Honest Operation,and Considerate Service”,our business mainly focus on the distribution of electronic components. Line cards we deal with include Microchip,ALPS,ROHM,Xilinx,Pulse,ON,Everlight and Freescale. Main products comprise IC,Modules,Potentiometer,IC Socket,Relay,Connector.Our parts cover such applications as commercial,industrial, and automotives areas.

We are looking forward to setting up business relationship with you and hope to provide you with the best service and solution. Let us make a better world for our industry!



## Contact us

Tel: +86-755-8981 8866 Fax: +86-755-8427 6832

Email & Skype: info@chipsmall.com Web: www.chipsmall.com

Address: A1208, Overseas Decoration Building, #122 Zhenhua RD., Futian, Shenzhen, China



# MAXIM

## Precision, Dual-Supply, SPST Analog Switches

MAX320/MAX321/MAX322

### General Description

The MAX320/MAX321/MAX322 are precision, dual, SPST analog switches designed to operate from  $\pm 3V$  to  $\pm 8V$  dual supplies. The MAX320 has two normally open (NO) switches and the MAX321 has two normally closed (NC) switches. The MAX322 has one NO and one NC switch. Low power consumption (1.25mW) makes these parts ideal for battery-powered equipment. They offer low leakage currents (100pA max) and fast switching speeds ( $t_{ON} = 150ns$  max,  $t_{OFF} = 100ns$  max).

The MAX320 series, powered from  $\pm 5V$  supplies, offers  $35\Omega$  max on-resistance ( $R_{ON}$ ),  $2\Omega$  max matching between channels, and  $4\Omega$  max  $R_{ON}$  flatness.

These switches also offer 5pC max charge injection and a minimum of 2000V ESD protection per Method 3015.7.

For equivalent devices specified for single-supply operation, see the MAX323/MAX324/MAX325 data sheet. For quad versions of these switches, see the MAX391/MAX392/MAX393 data sheet.

### Applications

- |                           |                              |
|---------------------------|------------------------------|
| Battery-Operated Systems  | Sample-and-Hold Circuits     |
| Heads-Up Displays         | Guidance and Control Systems |
| Audio and Video Switching | Military Radios              |
| Test Equipment            | Communications Systems       |
| $\pm 5V$ DACs and ADCs    | PBX, PABX                    |

### Features

- ◆ Low On-Resistance,  $35\Omega$  max ( $16\Omega$  typical)
- ◆  $R_{ON}$  Matching Between Channels  $<2\Omega$
- ◆  $R_{ON}$  Flatness  $<4\Omega$
- ◆ Guaranteed Charge Injection  $<5pC$
- ◆ Bipolar Supply Operation ( $\pm 3V$  to  $\pm 8V$ )
- ◆ Low Power Consumption,  $<1.25mW$
- ◆ Low Leakage Current Over Temperature,  $<2.5nA$  at  $+85^\circ C$
- ◆ Fast Switching,  $t_{ON} <150ns$ ,  $t_{OFF} <100ns$
- ◆ Guaranteed Break-Before-Make (MAX322 only)

### Ordering Information

PART	TEMP. RANGE	PIN-PACKAGE
MAX320CPA	$0^\circ C$ to $+70^\circ C$	8 Plastic DIP
MAX320CSA	$0^\circ C$ to $+70^\circ C$	8 SO
MAX320CUA	$0^\circ C$ to $+70^\circ C$	8 $\mu$ MAX
MAX320C/D	$0^\circ C$ to $+70^\circ C$	Dice*
MAX320EPA	$-40^\circ C$ to $+85^\circ C$	8 Plastic DIP
MAX320ESA	$-40^\circ C$ to $+85^\circ C$	8 SO
MAX320EJA	$-40^\circ C$ to $+85^\circ C$	8 CERDIP**
MAX320MJA	$-55^\circ C$ to $+125^\circ C$	8 CERDIP**

Ordering Information continued at end of data sheet.

\* Contact factory for dice specifications.

\*\* Contact factory for availability.

### Pin Configurations/Functional Diagrams/Truth Tables

TOP VIEW

MAX320  
DIP/SO/ $\mu$ MAX

MAX320	
LOGIC	SWITCH
0	OFF
1	ON

MAX321  
DIP/SO/ $\mu$ MAX

MAX321	
LOGIC	SWITCH
0	ON
1	OFF

MAX322  
DIP/SO/ $\mu$ MAX

MAX322		
LOGIC	SWITCH 1	SWITCH 2
0	OFF	ON
1	ON	OFF

SWITCHES SHOWN FOR LOGIC "0" INPUT

# Precision, Dual-Supply, SPST Analog Switches

## ABSOLUTE MAXIMUM RATINGS

Voltage Referenced to V-	$\mu$ MAX (derate 4.10mW/°C above +70°C) .....330mW
V+ .....(V- - 0.3V) to +17V	CERDIP (derate 8.00mW/°C above +70°C) .....640mW
IN_, COM_, NC_, NO_ (Note 1) .....(V- - 0.3V) to (V+ + 0.3V)	Operating Temperature Ranges
Continuous Current (any terminal) .....30mA	MAX32_C_ .....0°C to +70°C
Peak Current, COM_, NO_, NC_ (pulsed at 1ms, 10% duty cycle max) .....100mA	MAX32_E_ .....-40°C to +85°C
ESD per Method 3015.7 .....>2000V	MAX32_MJA .....-55°C to +125°C
Continuous Power Dissipation	Storage Temperature Range .....-65°C to +150°C
Plastic DIP (derate 9.09mW/°C above +70°C) .....727mW	Lead Temperature (soldering, 10sec) .....+300°C
Narrow SO (derate 5.88mW/°C above +70°C) .....471mW	

**Note 1:** Signals on NC\_, NO\_, COM\_, or IN\_ exceeding V+ or V- are clamped by internal diodes. Limit forward diode current to maximum current rating.

Stresses beyond those listed under "Absolute Maximum Ratings" may cause permanent damage to the device. These are stress ratings only, and functional operation of the device at these or any other conditions beyond those indicated in the operational sections of the specifications is not implied. Exposure to absolute maximum rating conditions for extended periods may affect device reliability.

## ELECTRICAL CHARACTERISTICS

(V+ = +5V  $\pm$ 10%, V- = -5V  $\pm$ 10%, VINH = 3.5V, VINL = 2.5V, TA = TMIN to TMAX, unless otherwise noted.)

PARAMETER	SYMBOL	CONDITIONS	MIN	TYP (Note 2)	MAX	UNITS		
<b>ANALOG SWITCH</b>								
Analog Signal Range	VCOM, VNO, VNC	(Note 3)	V-		V+	V		
On-Resistance	RON	V+ = 4.5V, V- = -4.5V, ICOM = 1.0mA, VNO or VNC = $\pm$ 3.5V	TA = +25°C	C, E	16	35	$\Omega$	
				M	16	30		
			TA = TMIN to TMAX			45		
On-Resistance Match Between Channels (Note 4)	$\Delta$ RON	V+ = 5V, V- = -5V, ICOM = 1.0mA, VNO or VNC = $\pm$ 3V	TA = +25°C		0.3	2	$\Omega$	
				TA = TMIN to TMAX				4
On-Resistance Flatness (Note 5)	RFLAT(ON)	V+ = 5V, V- = -5V, ICOM = 1.0mA, VNO or VNC = $\pm$ 3V	TA = +25°C		1	4	$\Omega$	
				TA = TMIN to TMAX				6
NO or NC Off Leakage Current (Note 6)	INO(OFF) or INC(OFF)	V+ = 5.5V, V- = -5.5V, VCOM = $\pm$ 4.5V, VNO or VNC = $\mp$ 4.5V	TA = +25°C		-0.1	0.01	0.1	nA
				TA = TMIN to TMAX	C, E	-5	5	
				M	-40	40		
COM Off Leakage Current (Note 6)	ICOM(OFF)	V+ = 5.5V, V- = -5.5V, VCOM = $\pm$ 4.5V, VNO or VNC = $\mp$ 4.5V	TA = +25°C		-0.1	0.01	0.1	nA
				TA = TMIN to TMAX	C, E	-5	5	
				M	-40	40		
COM On Leakage Current (Note 6)	ICOM(ON)	V+ = 5.5V, V- = -5.5V, VCOM = $\pm$ 4.5V, VNO or VNC = $\pm$ 4.5V	TA = +25°C		-0.2	0.05	0.2	nA
				TA = TMIN to TMAX	C, E	-10	10	
				M	-50	50		

# Precision, Dual-Supply, SPST Analog Switches

MAX320/MAX321/MAX322

## ELECTRICAL CHARACTERISTICS

(V+ = +5V ±10%, V- = -5V ±10%, VINH = 3.5V, VINL = 2.5V, TA = TMIN to TMAX, unless otherwise noted.)

PARAMETER	SYMBOL	CONDITIONS	MIN	TYP (Note 2)	MAX	UNITS	
<b>LOGIC INPUT</b>							
Input Current with Input Voltage High	I <sub>INH</sub>		-0.5	0.005	0.5	μA	
Input Current with Input Voltage Low	I <sub>INL</sub>		-0.5	0.005	0.5	μA	
Input Voltage High	V <sub>INH</sub>	V+ = 5V ±10%, V- ≤ 0V	3.5			V	
		3V < V+ < 8V, V- ≤ 0V	V+ - 1.5				
Input Voltage Low	V <sub>INL</sub>	V+ = 5V ±10%, V- ≤ 0V	2.5			V	
		3V < V+ < 8V, V- ≤ 0V	V+ - 2.5				
<b>DYNAMIC</b>							
Turn-On Time	t <sub>ON</sub>	V <sub>COM</sub> = ±3V, Figure 2	TA = +25°C	65	150	ns	
			TA = TMIN to TMAX	175			
Turn-Off Time	t <sub>OFF</sub>	V <sub>COM</sub> = ±3V, Figure 2	TA = +25°C	35	100	ns	
			TA = TMIN to TMAX	150			
Break-Before-Make Time Delay (Note 3)	t <sub>D</sub>	MAX322 only, RL = 300Ω, CL = 35pF, Figure 3	2	5		ns	
Charge Injection (Note 3)	Q	CL = 1.0nF, VGEN = 0V, RGEN = 0Ω, Figure 4	TA = +25°C	2	5	pC	
Off Isolation (Note 7)	OIRR	RL = 50Ω, CL = 5pF, f = 1MHz, Figure 5	TA = +25°C	72		dB	
Crosstalk (Note 8)		RL = 50Ω, CL = 5pF, f = 1MHz, Figure 6	TA = +25°C	85		dB	
NC or NO Capacitance	C <sub>(OFF)</sub>	f = 1MHz, Figure 7	TA = +25°C	9		pF	
COM Off Capacitance	C <sub>COM(OFF)</sub>	f = 1MHz, Figure 7	TA = +25°C	9		pF	
COM On Capacitance	C <sub>COM(ON)</sub>	f = 1MHz, Figure 8	TA = +25°C	22		pF	
<b>SUPPLY</b>							
Power-Supply Range			±2.7		±8	V	
Positive Supply Current	I+	V+ = 5.5V, V- = -5.5V, VIN = 0V or V+, all channels on or off	TA = +25°C	-125	80	125	μA
			TA = TMIN to TMAX	-200	200		
Negative Supply Current	I-	V+ = 5.5V, V- = -5.5V, VIN = 0V or V+, all channels on or off	TA = +25°C	-125	80	125	μA
			TA = TMIN to TMAX	-200	200		

**Note 2:** The algebraic convention where the most negative value is a minimum and the most positive value a maximum is used in this data sheet.

**Note 3:** Guaranteed by design.

**Note 4:** ΔRON = ΔRON max - ΔRON min.

**Note 5:** Flatness is defined as the difference between the maximum and minimum value of on-resistance as measured over the specified analog signal range.

**Note 6:** Leakage parameters are 100% tested at maximum rated hot temperature and guaranteed by correlation at +25°C.

**Note 7:** Off Isolation = 20 log<sub>10</sub> [ V<sub>COM</sub> / (V<sub>NC</sub> or V<sub>NO</sub>) ], V<sub>COM</sub> = output, V<sub>NC</sub> or V<sub>NO</sub> = input to off switch.

**Note 8:** Between any two switches.

# Precision, Dual-Supply, SPST Analog Switches

## Typical Operating Characteristics

( $V_+ = +5V$ ,  $V_- = -5V$ ,  $T_A = +25^\circ C$ , unless otherwise noted.)

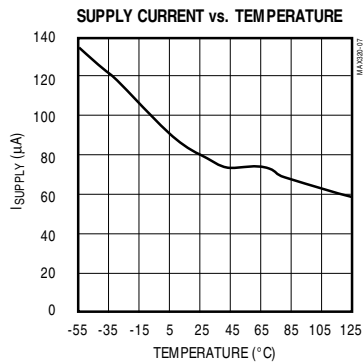
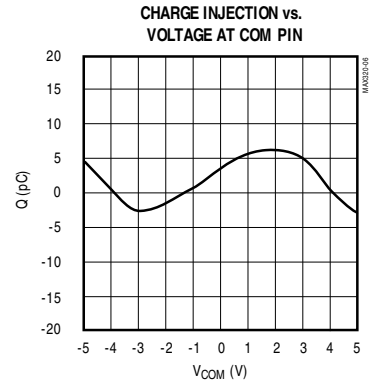
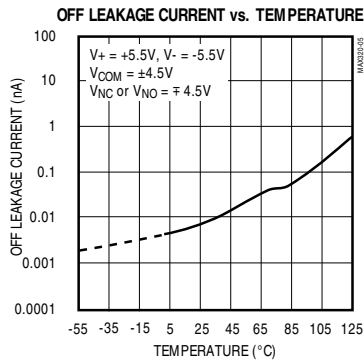
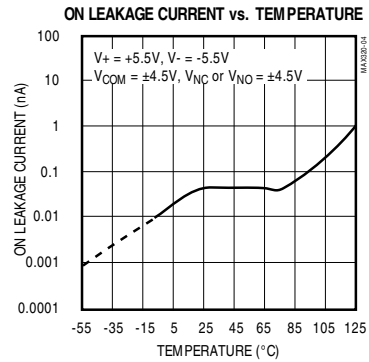
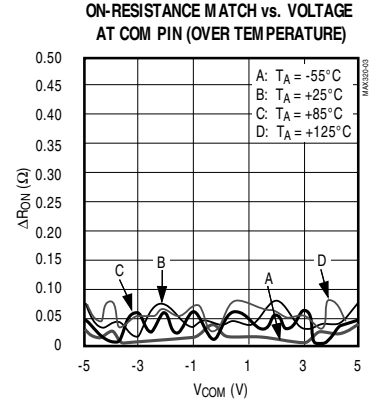
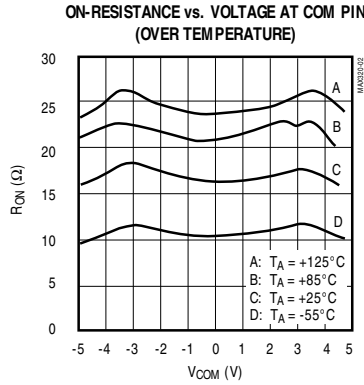
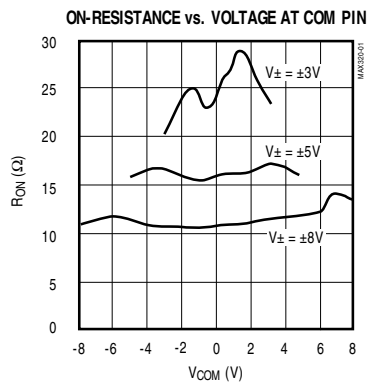

# Precision, Dual-Supply, SPST Analog Switches

## Pin Description

PIN	NAME	FUNCTION
1	NO1 (MAX320/MAX322)	Normally Open Analog Switch Terminal
	NC1 (MAX321)	Normally Closed Analog Switch Terminal
2, 6	COM1, COM2	Analog Switch Common Terminals
3, 7	IN2, IN1	Logic Inputs
4	V-	Negative Supply
5	NO2 (MAX320)	Normally Open Analog Switch Terminal
	NC2 (MAX321/MAX322)	Normally Closed Analog Switch Terminal
8	V+	Positive Supply

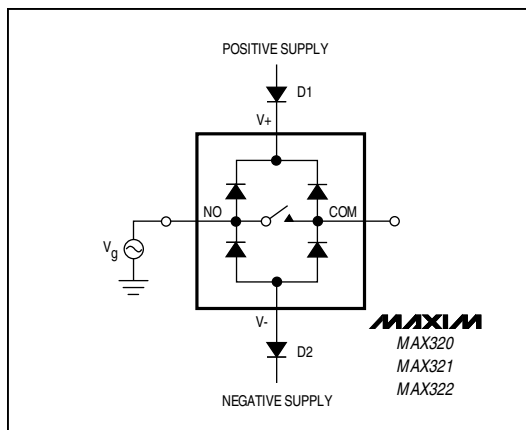

Figure 1. Overvoltage Protection Using Two External Blocking Diodes

## Applications Information

### Logic Levels

Calculate the logic thresholds typically as follows:  $V_{IH} = (V_+ - 1.5V)$  and  $V_{IL} = (V_+ - 2.5V)$ .

Power-supply consumption is minimized when IN1 and IN2 are driven with logic-high levels equal to  $V_+$  and logic-low levels well below the calculated  $V_{IL}$  of  $(V_+ - 2.5V)$ . IN1 and IN2 can be driven to  $V_-$  without damage.

### Analog Signal Levels

Analog signals that range over the entire supply voltage ( $V_-$  to  $V_+$ ) can be switched, with very little change in on-resistance over the entire voltage range (see *Typical Operating Characteristics*). All switches are bidirectional, so NO\_, NC\_, and COM\_ pins can be used as either inputs or outputs.

### Power-Supply Sequencing and Overvoltage Protection

Do not exceed the absolute maximum ratings, because stresses beyond the listed ratings may cause permanent damage to the devices.

Proper power-supply sequencing is recommended for all CMOS devices. Always apply  $V_+$ , followed by  $V_-$ , before applying analog signals or logic inputs, especially if the analog or logic signals are not current-limited. If

this sequencing is not possible, and if the analog or logic inputs are not current-limited to  $<30mA$ , add two small signal diodes (D1, D2) as shown in Figure 1. Adding protection diodes reduces the analog signal range to a diode drop (about 0.7V) below  $V_+$  for D1, and a diode drop above  $V_-$  for D2. Leakage is not affected by adding the diodes. On-resistance increases by a small amount at low supply voltages. Maximum supply voltage ( $V_-$  to  $V_+$ ) must not exceed 17V.

Adding protection diode D1 causes the logic thresholds to be shifted relative to the positive power-supply rail. This can be significant when low positive supply voltages (+5V or less) are used. Driving IN1 and IN2 all the way to the supply rails (i.e., to a diode drop higher than the  $V_+$  pin or a diode drop lower than the  $V_-$  pin) is always acceptable.

The protection diodes D1 and D2 also protect against some overvoltage situations. With the circuit of Figure 1, if the supply voltage is below the absolute maximum rating and if a fault voltage up to the absolute maximum rating is applied to an analog signal pin, no damage will result. For example, with  $\pm 5V$  supplies, analog signals up to  $\pm 8.5V$  will not damage the circuit of Figure 1. If only a single fault signal is present, the fault voltage can rise to +12V or to -12V without damage.

MAX320/MAX321/MAX322

# Precision, Dual-Supply, SPST Analog Switches

## Test Circuits/Timing Diagrams

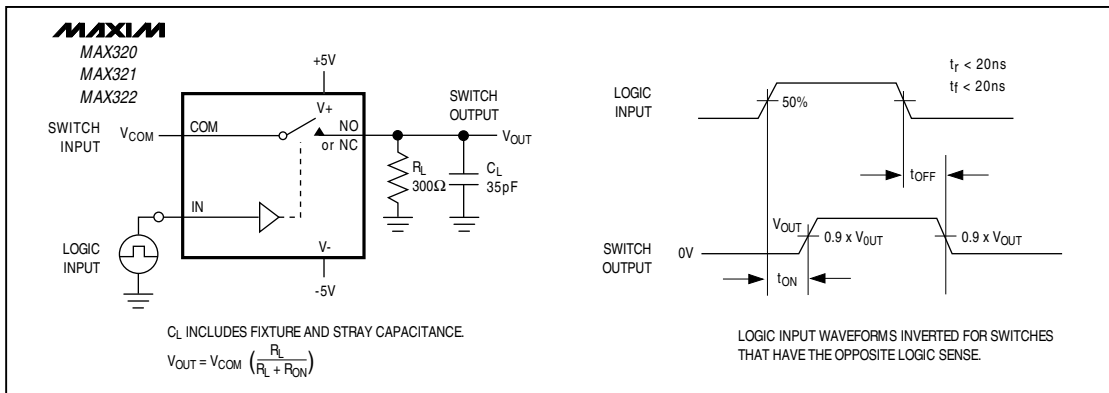

Figure 2. Switching Time

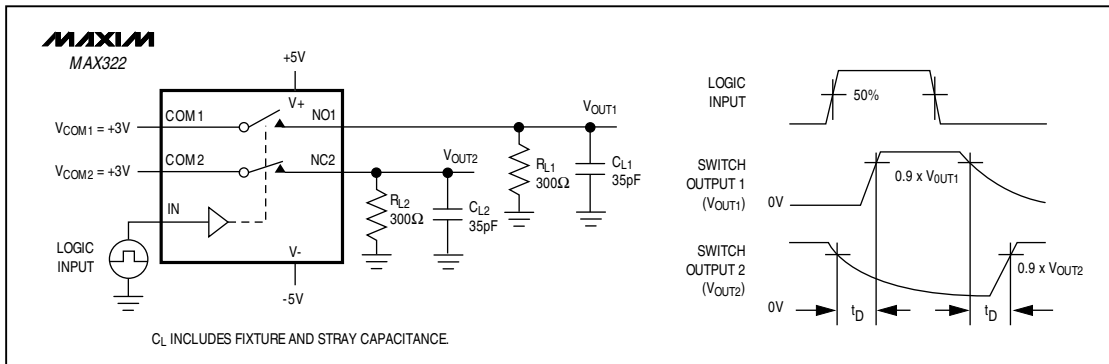

Figure 3. Break-Before-Make Interval (MAX322 only)

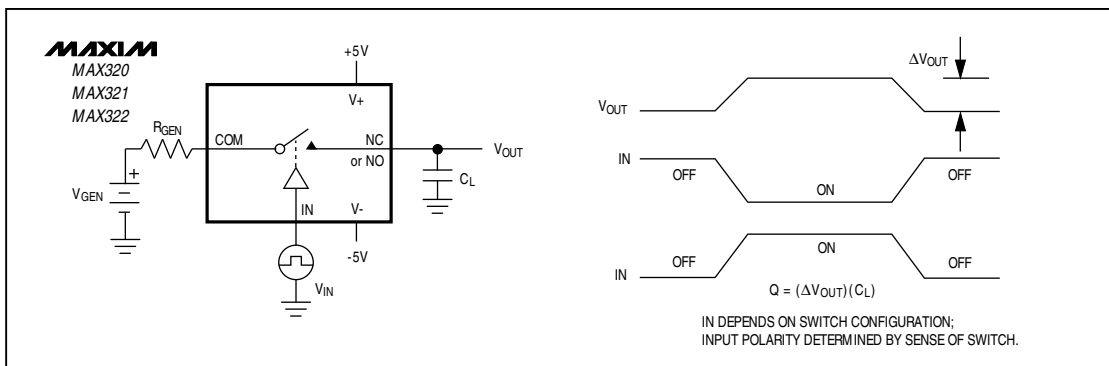

Figure 4. Charge Injection

# Precision, Dual-Supply, SPST Analog Switches

## Test Circuits/Timing Diagrams (continued)

MAX320/MAX321/MAX322

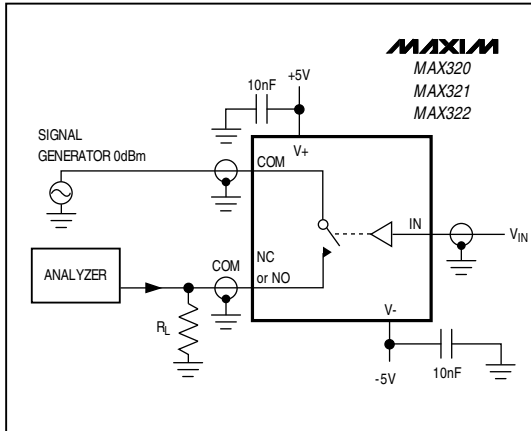

Figure 5. Off Isolation

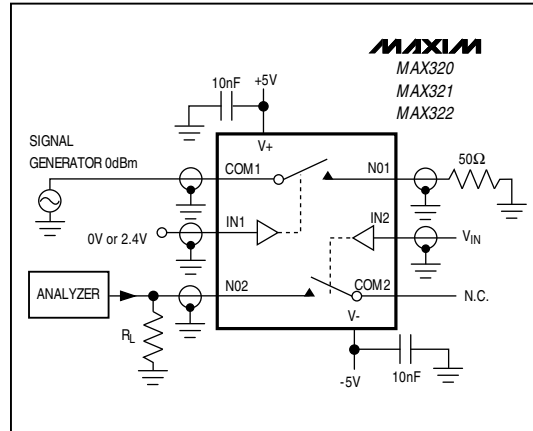

Figure 6. Crosstalk

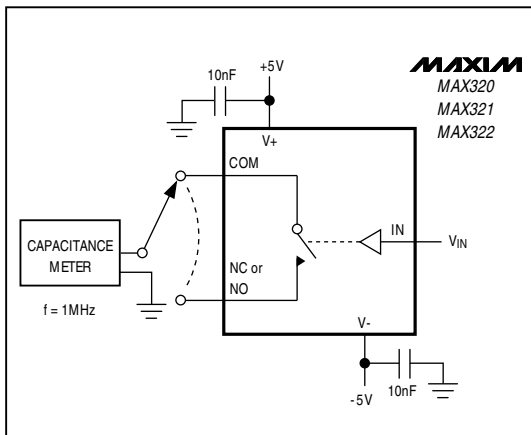

Figure 7. Channel-Off Capacitance

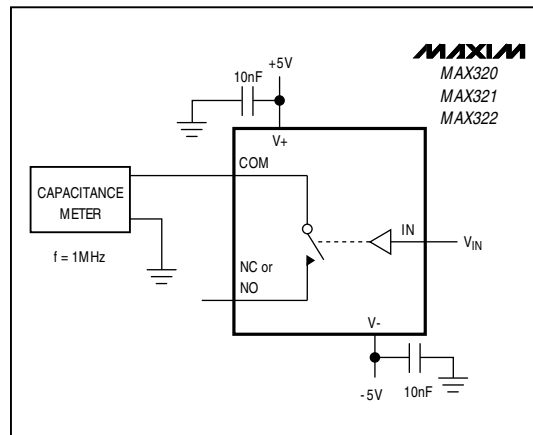

Figure 8. Channel-On Capacitance



# Precision, Dual-Supply, SPST Analog Switches

## Ordering Information (continued)

PART	TEMP. RANGE	PIN-PACKAGE
MAX321CPA	0°C to +70°C	8 Plastic DIP
MAX321CSA	0°C to +70°C	8 SO
MAX321CUA	0°C to +70°C	8 $\mu$ MAX
MAX321C/D	0°C to +70°C	Dice*
MAX321EPA	-40°C to +85°C	8 Plastic DIP
MAX321ESA	-40°C to +85°C	8 SO
MAX321EJA	-40°C to +85°C	8 CERDIP**
MAX321MJA	-55°C to +125°C	8 CERDIP**
MAX322CPA	0°C to +70°C	8 Plastic DIP
MAX322CSA	0°C to +70°C	8 SO
MAX322CUA	0°C to +70°C	8 $\mu$ MAX
MAX322C/D	0°C to +70°C	Dice*
MAX322EPA	-40°C to +85°C	8 Plastic DIP
MAX322ESA	-40°C to +85°C	8 SO
MAX322EJA	-40°C to +85°C	8 CERDIP**
MAX322MJA	-55°C to +125°C	8 CERDIP**

\* Contact factory for dice specifications.

\*\* Contact factory for availability.

## Chip Topography

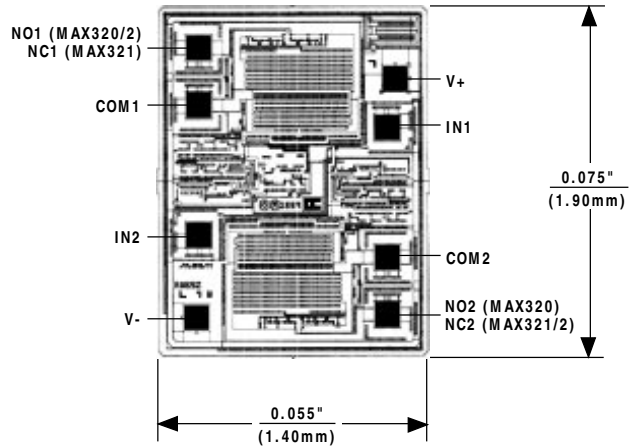

TRANSISTOR COUNT: 91  
SUBSTRATE CONNECTED TO V+

## Package Information

DIM	INCHES		MILLIMETERS	
	MIN	MAX	MIN	MAX
A	0.036	0.044	0.91	1.11
A1	0.004	0.008	0.10	0.20
B	0.010	0.014	0.25	0.36
C	0.005	0.007	0.13	0.18
D	0.116	0.120	2.95	3.05
E	0.116	0.120	2.95	3.05
e	0.0256		0.65	
H	0.188	0.198	4.78	5.03
L	0.016	0.026	0.41	0.66
$\alpha$	0°	6°	0°	6°

**8-PIN  $\mu$ MAX  
MICROMAX SMALL OUTLINE  
PACKAGE**

Maxim cannot assume responsibility for use of any circuitry other than circuitry entirely embodied in a Maxim product. No circuit patent licenses are implied. Maxim reserves the right to change the circuitry and specifications without notice at any time.

8 Maxim Integrated Products, 120 San Gabriel Drive, Sunnyvale, CA 94086 (408) 737-7600

© 1994 Maxim Integrated Products

Printed USA

MAXIM is a registered trademark of Maxim Integrated Products.