



Chipsmall Limited consists of a professional team with an average of over 10 year of expertise in the distribution of electronic components. Based in Hongkong, we have already established firm and mutual-benefit business relationships with customers from,Europe,America and south Asia,supplying obsolete and hard-to-find components to meet their specific needs.

With the principle of “Quality Parts,Customers Priority,Honest Operation,and Considerate Service”,our business mainly focus on the distribution of electronic components. Line cards we deal with include Microchip,ALPS,ROHM,Xilinx,Pulse,ON,Everlight and Freescale. Main products comprise IC,Modules,Potentiometer,IC Socket,Relay,Connector.Our parts cover such applications as commercial,industrial, and automotives areas.

We are looking forward to setting up business relationship with you and hope to provide you with the best service and solution. Let us make a better world for our industry!



Contact us

Tel: +86-755-8981 8866 Fax: +86-755-8427 6832

Email & Skype: info@chipsmall.com Web: www.chipsmall.com

Address: A1208, Overseas Decoration Building, #122 Zhenhua RD., Futian, Shenzhen, China



MAX32625/MAX32626 Evaluation Kits

Evaluate: MAX32625, MAX32626

General Description

The MAX32625/MAX32626 evaluation kit (EV kit) provides a convenient platform for evaluating the capabilities of the MAX32625/MAX32626 microcontroller. The EV kit also provides a complete, functional system ideal for developing and debugging applications.

EV Kit Contents

- EV kit board with a MAX32625 or MAX32626 microcontroller
- Olimex ARM-USB-TINY-H JTAG debugger with JTAG ribbon cable (for connecting from debugger to EV kit header J1) and USB standard A-to-B cable (for connecting from PC to debugger)
- Standard-A to Micro-B USB cable (for connecting from PC or standalone USB power supply to EV kit USB Micro-B connector CN2) allows connection from PC USB host to the IC's USB device controller peripheral
- Standard-A to Micro-B USB cable (for connecting PC to EV kit USB connector CN1) allows virtual COM port interface to the IC's UART 0 or UART 1 through a USB/UART bridge
- MAX32625/MAX32626 EV Kit Quick Start Guide
- Hex Keys for the Socket (MAX32626 EV Kit Only)

Benefits and Features

- Easily Load and Debug Code Using the Supplied Olimex ARM-USB-TINY-H JTAG Debugger Connected Through a Standard 20-Pin ARM JTAG Header
- Selectable Power Sources for PMIC Include USB Power Through the CN1 or CN2 Connector, Optional External Battery Through J2 Connector, or Bench Supply Through Test Points TP8 and TP9
- Selectable Power Source for On-Board Peripherals (Switches, LEDs, OLED Display, SPI Flash, Bluetooth® LE Transceiver)
- Headers for Accessing the IC's I/O Pins and Analog Front End (AFE) Input Signals
- USB Micro-B Connection to the IC's USB Device Controller
- USB Micro-B Connection to USB-UART Bridge Selectable Between the IC's Internal UART 0 and UART 1
- On-Board Bluetooth 4.0 BLE Transceiver with Chip Antenna
- General-Purpose Pushbutton Switches and Indicator LEDs (All Connected to GPIOs) for User I/O
- Prototyping Matrix (0.1in Grid) with Integrated Power Rails for Customer Circuitry

MAX32625 EV Kit



Ordering Information appears at end of data sheet.

The Bluetooth word mark and logos are registered trademarks owned by Bluetooth SIG, Inc. and any use of such marks by Maxim is under license.

Getting Started

- 1) While observing safe ESD practices, carefully remove the EV kit board out of its packaging. Quickly inspect the board to ensure that no damage occurred during shipment. Jumpers/shunts were preinstalled prior to testing and packaging. By default, the USB-UART bridge is the source of power for the EV kit board. See [Table 1](#) and [Figure 3](#) for the default settings and descriptions.
- 2) The IC is preprogrammed with a demo program. To power up the board and run the demo, simply connect the Micro-USB cable to the Micro-USB jack found at the top left of the EV kit PCB. The jack is labeled CN1. The other end of the Micro-USB cable can be connected either to a computer **or** to a USB wall charger to get +5V power.
- 3) Once power is applied, the demo initiates. The demo displays text and graphics on the OLED display, flashes LED0–LED3, and outputs data to UART0.
- 4) Do not connect any of the additional USB cables or Olimex JTAG adapter until after the tool chain/drivers are installed.

If the demo runs as expected, the next step is to download and run the installer. Refer to the EV kit's quick start guide. The installer is a small application that allows the user to select which components to download and install including tools, drivers, and documentation. A description of each component and the hard drive size required for each can be seen by clicking on each component.

Detailed Description

This section describes each major function or component on the EV kit. This EV kit is general purpose in nature and provides many user-selectable options that are described in the following sections. Each jumper setting is described and its default setting illustrated.

Board Power

The EV kit's main power supply input is +5V, made available through Micro-USB type-B connector CN1 or CN2. The board is default jumpered for power to be provided by CN1.

Current Monitoring

Jumpers JP15, JP16, JP18, and JP19 provide convenient current monitoring points for VDD12 (JP15), VRTC (JP18), VDDDB (JP19), and VDD18 (JP16). VDDIO (JP27) and VDDIOH (JP28) current can be monitored using these source selection jumpers.

Pushbuttons

Pushbuttons (normally open) SW1, SW2, and SW3 can be used to generate a logic 0 signal on their corresponding GPIO port pins. Firmware defines the action taken on switch closure.

Pushbutton SW4 provides a global POR reset function for the IC by asserting the RSTN input.

Pushbutton SW5 controls the PFN1 input of the PMIC. The function of the PFN1 input is configurable but is preset to reset the PMIC when depressed for at least 12 seconds.

USB

The IC provides an integrated USB2.0 full-speed interface (12Mbps). This interface is accessed through the Micro-USB type-B connector, CN2.

USB-UART Bridge

The EV kit board provides a USB-to-UART bridge chip, FTDI FT230X. This bridge eliminates the requirement for a physical RS-232 COM port. Instead, the IC's UART access is through the Micro-USB type-B connector, CN1. Virtual COM port drivers and guides for installing Windows® drivers are available at the FTDI Chip website. Default parameters are 115,200 baud, 8 bits, no parity, 1 stop bit, no flow control.

The USB-to-UART bridge can be connected to UART 0 or UART 1 of the IC with jumpers JP10 (RX), JP12 (TX), JP13 (CTS), and JP14 (RTS). This interface is the default power source for the EV kit.

LEDs

The EV kit board has four LEDs with series current-limiting resistors. LEDs D1 (red), D2 (green), D3 (red), and D4 (green) are connected to the IC's GPIO pins P3.0, P3.1, P3.2, and P3.3, respectively. LED GPIOs must be configured as open-drain due to 3.3V LED source voltages. A LED illuminates when the appropriate GPIO pin is driven low.

Bluetooth Low-Energy (BLE) Controller

The EV kit board has a low-power Bluetooth controller, EM9301. Communication with the IC is through SPIM2. This particular SPI port was selected due to the additional flow control signals that it features. The EM9301 controller is Bluetooth specification V4.0 compliant. Refer to the EM Microelectronic EM9301 data sheet for additional details.

Windows is a registered trademark and service mark of Microsoft Corp

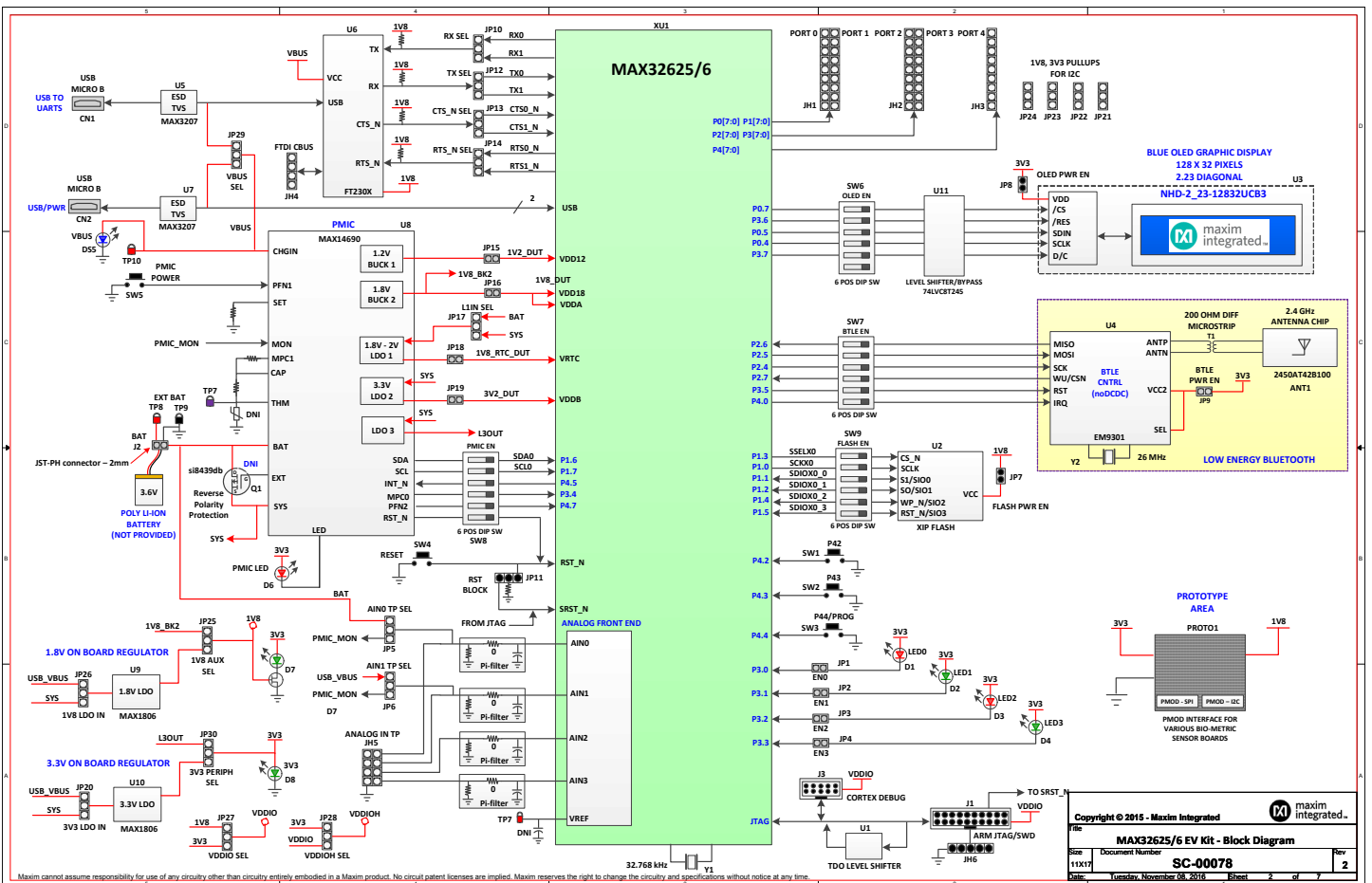

Figure 1. EV Kit Block Diagram

Clocking

The IC operates from an internal 96MHz relaxation oscillator. The internal oscillator is adequate to run the core digital logic and peripherals. The accuracy of the internal oscillator is not suitable for accurate RTC timekeeping or USB operation. The external 32.768kHz crystal, Y1, provides the RTC with an accurate time base and is also used to calibrate the internal oscillator for the accuracy required for USB operation.

JTAG Connector

The ARM standard 20-pin connector pinout is provided by shrouded header J1. JH6 is provided as an optional debugging access point, it is not populated by default. The Olimex ARM-USB-TINY-H debugger is supplied with the EV kit. Various debugger modules are available for this interface. See the schematic notes for instructions when using other than supplied debugger. JTAG logic levels are set by VDDIO and are 3.3V tolerant. Refer to the IC's data sheet for more detail.

JTAG Serial Wire Debug (SWD) Support

SWD is supported by the IC and this EV kit. The port shares its clock (SWCLK) with JTAG TCK and a bidirectional data pin (SWDIO) is shared with JTAG TMS.

Graphic OLED Display Module

A 128 x 32 pixel graphic OLED display module, NHD-2.23-12832UCB3, is provided on the EV kit board. Communications with the NHD-2.23-12832UCB3 is through SPIM0.

Power Management IC (PMIC)

The MAX14690 manages the EV kit power rails. It also manages the selection of EV kit power from either VBUS from CN1 or CN2 or an (optional) external lithium-ion polymer battery. The MAX14690 can also function as a battery charger. Refer to the MAX14690 IC data sheet for additional information.

GPIO Headers and Port configuration

The IC provides support for both 1.8V and 3.3V peripherals through power rails VDDIO and VDDIOH. GPIO voltages can be programmed on a port-by-port basis, refer to the IC's user's guide for more detail. Multiple pullup options are supported when using special function port modes, with user selectable pullup voltage options to both rail voltages supported through jumper selection.

Prototyping Area

An area for adding customer-specific circuitry is provided. This matrix is on a 0.1in spacing and is usable for solder or wire-wrap construction. Power and ground rails run through the matrix.

Jumper Descriptions

[Table 1](#) details the functions of the configurable jumper headers on the EV kit board. The headers are standard 0.1in spacing, 0.025in posts. Settings in [Table 1](#) marked with an asterisk (“*”) indicate default placements. [Figure 3](#) also shows the default placements highlighted in red.

Table 1. Jumper Functions and Default Settings

JUMPER	SIGNAL	SETTINGS	DESCRIPTION
JP1	P3_0	1-2*	Connects P3_0 to LED0
		Open	Disconnects LED0
JP2	P3_1	1-2*	Connects P3_1 to LED1
		Open	Disconnects LED1
JP3	P3_2	1-2*	Connects P3_2 to LED2
		Open	Disconnects LED2
JP4	P3_3	1-2*	Connects P3_3 to LED3
		Open	Disconnects LED3
JP5	AIN0	1-2	Connects AIN0 to BAT
		2-3	Connects AIN0 to PMIC_MON
JP6	AIN1	1-2	Connects AIN1 to VBUS
		2-3	Connects AIN1 to PMIC_MON

Table 1. Jumper Functions and Default Settings (continued)

JUMPER	SIGNAL	SETTINGS	DESCRIPTION
JP7	1V8	1-2*	Connects FLASH VCC to 1V8 power
		Open	Disconnects FLASH VCC
JP8	3V3	1-2*	Connects OLED display to 3V3 power
		Open	Disconnects OLED display
JP9	3V3	1-2*	Connects BTLE to 3V3 power
		Open	Disconnects BTLE
JP10	TXD of USB-SERIAL IC	1-2*	Connects TXD of USB—Serial IC to P0_0 (UART0A_RX)
		2-3	Connects TXD of USB—Serial IC to P2_0 (UART1A_RX)
JP11	—	—	Not applicable
JP12	RXD of USB-SERIAL IC	1-2*	Connects RXD of USB—Serial IC to P0_1 (UART0A_TX)
		2-3	Connects RXD of USB—Serial IC to P2_1 (UART1A_TX)
JP13	RTS of USB-SERIAL IC	1-2*	Connects RTS of USB—Serial IC to P0_2 (UART0A_CTS)
		2-3	Connects RTS of USB—Serial IC to P2_2 (UART1A_CTS)
JP14	CTS of USB-SERIAL IC	1-2*	Connects CTS of USB—Serial IC to P0_3 (UART0A_RTS)
		2-3	Connects CTS of USB—Serial IC to P2_3 (UART1A_RTS)
JP15	VDD12	1-2*	Connects VDD12 to the PMIC B1OUT (1V2)
		Open	Disconnects the PMIC B2OUT (1V2)
JP16	VDD18	1-2*	Connects VDD18 to the PMIC B1OUT (1V8)
		Open	Disconnects the PMIC B1OUT (1V8)
JP17	L1IN of PMIC	1-2	Connects L1IN of the PMIC to BAT (battery)
		2-3*	Connects L1IN of the PMIC to SYS
JP18	VRTC	1-2*	Connects VRTC to the PMIC L1OUT (1V8)
		Open	Disconnects the PMIC L1OUT (1V8)
JP19	VDDB	1-2*	Connects VDDB to the PMIC L2OUT (3V2)
		Open	Disconnects the PMIC L2OUT (3V2)
JP20	IN of the 3V3 LDO	1-2*	Connects IN of the 3V3 on-board LDO to VBUS
		2-3	Connects IN of the 3V3 on-board LDO to SYS
JP21	P3_4	1-2	Connects P3_4 to 1V8 10kΩ pullup
		2-3	Connects P3_4 to 3V3 10kΩ pullup
JP22	P3_5	1-2	Connects P3_5 to 1V8 10kΩ pullup
		2-3	Connects P3_5 to 3V3 10kΩ pullup
JP23	P1_6	1-2	Connects P1_6 to 1V8 10kΩ pullup
		2-3	Connects P1_6 to 3V3 10kΩ pullup
JP24	P1_7	1-2	Connects P1_7 to 1V8 10kΩ pullup
		2-3	Connects P1_7 to 3V3 10kΩ pullup

Table 1. Jumper Functions and Default Settings (continued)

JUMPER	SIGNAL	SETTINGS	DESCRIPTION
JP25	1V8	1-2*	Connects 1V8 to PMIC B2OUT (1V8)
		2-3	Connects 1V8 to 1V8 on-board LDO
JP26	IN of the 1V8 LDO	1-2*	Connects IN of the 1V8 on-board LDO to VBUS
		2-3	Connects IN of the 1V8 on-board LDO to SYS
JP27	VDDIO	1-2*	Connects VDDIO to 1V8
		2-3	Connects VDDIO to 3V3
JP28	VDDIOH	1-2*	Connects VDDIOH to 3V3
		2-3	Connects VDDIOH to VDDIO
JP29	USB_VBUS	1-2*	Connects USB_VBUS to USB-UARTS (CN1)
		2-3	Connects USB_VBUS to USB (CN2)
JP30	3V3	1-2	Connects 3V3 to PMIC L3OUT (3V0)
		2-3*	Connects 3V3 to 3V3 on-board LDO

*Default position.

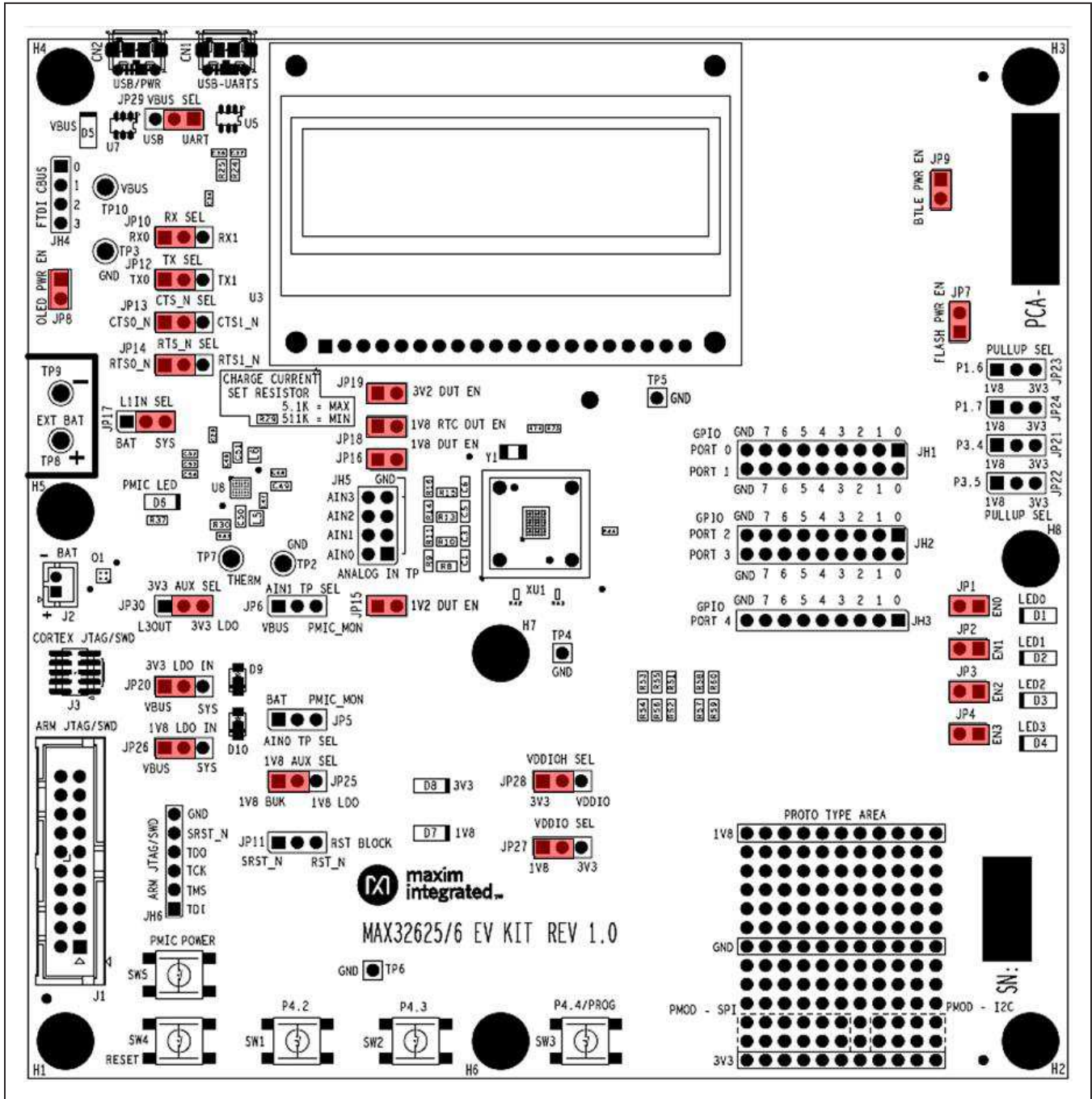

Figure 3. Default Jumper Placement

Additional Resources

- MAX32625/MAX32626 EV kit Quick Start
- MAX32625/MAX32626 EV kit data sheet (this document)
- MAX32625/MAX32626 EV kit schematic (attached to this PDF)
- MAX32625/MAX32626 data sheet
- MAX32625/MAX32626 User's Guide
- Getting Started with Eclipse Using the Maxim ARM® Cortex® Toolchain*
- MAX326XX SDK: Firmware Developer's Guide*
- Example projects*

*Additional information resides in the installer. Once installed, the information can be found in the Windows **Start** Menu under **Maxim Integrated**, or it can be found by exploring the installation directory. It is recommended to visit www.maximintegrated.com to check whether updates have been made to any of the documents.

Technical Support

For technical support, go to:

<http://support.maximintegrated.com/micro>.

Ordering Information

PART	TYPE
MAX32625-EVKIT#	EV Kit
MAX32626-EVKIT#	EV Kit

#Denotes RoHS compliant.

ARM and Cortex are registered trademarks of ARM Limited (or its subsidiaries) in the EU and/or elsewhere. All rights reserved.

MAX32625/MAX32626 Evaluation Kits

Evaluate: MAX32625, MAX32626

MAX32625/MAX32626 EV Kit Bill of Materials

QTY	PART	VALUE	BOM DESCRIPTION	MANUFACTURER PN	MANUFACTURER
1	ANT1	2450AT42B100E	ANTENNA CHIP 2.4GHZ	2450AT42B100E	Johanson Technology Inc
8	BMP1,BMP2,BMP3,BMP4,BMP5,BMP6,BMP7,BMP8	RB Bump	BUMPER RECESSED #4 SCREW BLACK	720	Keystone Electronics
4	C1,C3,C5,C6	DNI	DNI		
16	C2,C4,C7,C8,C9,C10,C21,C29,C46,C47,C48,C52,C53,C54,C56,C59	1uF	CAP CER 1UF 6.3V 10% X5R 0402	C1005X5R01105K050B8	TDK Corporation
1	C11	DNI	DNI	C0603C30015GACTU	Kemet
2	C12,C33	4.7nF	CAP CER 4700PF 25V 10% X7R 0402	GRM155R71E472KA01D	Murata
12	C13,C14,C17,C20,C24,C27,C28,C34,C39,C58,C60,C61	100nF	CAP CER 0.1UF 10V 10% X5R 0402	GRM155R61A104KA01D	Murata
1	C15	DNI	DNI	GRM155R71E472KA01D	Murata
2	C16,C31	1uF	CAP CER 1uF 16V 10% X7R 0603	GCM188R71C105KA64D	Murata
2	C18,C57	10uF	CAP CER 10UF 6.3V 20% X5R 0603	CL10A106MQ8NNNC	Samsung
2	C19,C55	22uF	CAP CER 22UF 6.3V 20% X5R 1206	C3216X5R01226M/0.85	TDK Corporation
2	C22,C23	15pF	CAP CER 15PF 50V 5% NPO 0402	GRM1555C1H150JA01D	Murata
1	C25	47uF	CAP CER 47uF 6.3V 20% X5R 1206	C3216X5R01476M	TDK Corporation
1	C26	DNI	DNI		
2	C30,C32	100pF	CAP CER 100PF 50V 5% NPO 0402	C1005C0G1H101J050BA	TDK Corporation
2	C35,C44	10nF	CAP CER 10nF 25V 10% X7R 0603	GRM188R71E103KA01D	Murata
2	C36,C37	47pF	CAP CER 47PF 50V 1% NPO 0402	C1005C0G1H470F050BA	TDK Corporation
1	C38	4.7uF	CAP CER 4.7uF 10V 10% X5R 0603	C0603C475K8PACTU	Kemet
3	C40,C42,C45	100nF	CAP CER 0.1UF 25V 10% X8R 0603	C1608X8R1E104K080AA	TDK Corporation
1	C41	100nF	CAP CER 0.1uF 16V 10% X7R 0603	C0603C104K4RACTU	Kemet
1	C43	1uF	CAP CER 1UF 35V 10% X5R 0603	GMK107B1105KA-T	Taiyo Yuden
3	C49,C50,C51	22uF	CAP CER 22UF 4V 20% X5R 0603	AMK107B1226MA-T	Taiyo Yuden
2	CN1,CN2	MICRO USB R/A	CONN RCPT MICRO USB R/A SMD	105017-0001	Molex
2	D1,D3	RED	LED 660NM RED WTR CLR 1206 SMD	SML-LX1206SRC-TR	Lumex Opto
4	D2,D4,D7,D8	GRN	LED 565NM WTR CLR GREEN 1206 SMD	SML-LX1206GC-TR	Lumex Opto
1	D5	BLUE	LED 469NM BLUE DIFF 1206 SMD	HSMR-C150	Avago Technologies US Inc.
1	D6	DNI	DNI	SML-LX1206SRC-TR	Lumex Opto
2	D9,D10	DFLS230L-7	DIODE SCHOTTKY 30V 2A POWERDI123	DFLS230L-7	Diodes Inc
8	H1,H2,H3,H4,H5,H6,H7,H8	DNI	DNI	DNI	
1	HDR1	20P 1x20	CONN HEADER .100 SINGL STR 20POS	PEC20SAAN	Sullins
1	J1	20P 10x2	CONN HEADER LOPRO STR 20POS GOLD	5103308-5	TE Connectivity
1	J2	DNI	CONN HEADER PH TOP 2POS 2MM	B2B-PH-K-S(LF)(SN)	JST Sales America Inc
1	J3	10P CORTEX DEBUG	CONN HEADER 10POS DUAL .05" SMD	FTSH-105-01-F-DV-K	Samtec
2	JH1,JH2	JH1 2x9	CONN HEADER .100 DUAL STR 18POS	PEC09DAAN	Sullins
1	JH3	9P 1x9	CONN HEADER .100 SINGL STR 9POS	PEC09SAAN	Sullins
1	JH4	DNI	CONN HEADER .100 SINGL STR 4POS	PEC04SAAN	Sullins
1	JH5	8P 2x4	CONN HEADER .100 DUAL STR 8POS	PEC04DAAN	Sullins
1	JH6	DNI	CONN HEADER .100 SINGL STR 6POS	PEC06SAAN	Sullins
11	JP1,JP2,JP3,JP4,JP7,JP8,JP9,JP15,JP16,JP18,JP19	JUMPER	CONN HEADER .100 SINGL STR 2POS	PEC02SAAN	Sullins
18	JP5,JP6,JP10,JP12,JP13,JP14,JP17,JP20,JP21,JP22,JP23,JP24,JP25,JP26,JP27,JP28,JP29,JP30	3P 3x1	CONN HEADER .100 SINGL STR 3POS	PEC03SAAN	Sullins
1	JP11	DNI	CONN HEADER .100 SINGL STR 3POS	PEC03SAAN	Sullins
1	L1	3.3nH	INDUCTOR MULTILAYER 3.3NH 0402	MLK100553N3ST000	TDK Corporation
1	L2	1.5nH	INDUCTOR MULTILAYER 1.5NH 0402	MLK100551N5ST000	TDK Corporation
2	L3,L4	HZ1206C202R-10	FERRITE CHIP SIGNAL 2000 OHM SMD	HZ1206C202R-10	Laird-Signal Integrity Products
2	L5,L6	2.2uH	INDUCTOR POWER 2.2UH 1.05A SMD	VLS201610ET-2R2M	TDK Corporation
1	L7	BLM21PG2215N1D	FERRITE CHIP 220 OHM 0805	BLM21PG2215N1D	Murata Electronics
8	MS1,MS2,MS3,MS4,MS5,MS6,MS7,MS8	Screw Steel	MACHINE SCREW PAN PHILLIPS 4-40	PMS55 440 0025 PH	B&F Fastener Supply
8	MST1,MST2,MST3,MST4,MST5,MST6,MST7,MST8	STANDOFF	HEX STANDOFF 4-40 ALUMINUM 5/8"	1808	Keystone Electronics
1	PCB1	PCB			
1	PROTO1	DNI	Proto Type Area 11x13 (0.1" LS)		
1	Q1	DNI	MOSFET P-CH 8V MICROFOOT	S18439DB-T1-E1	Vishay Siliconix
1	Q2	MMBT2222ALT1G	TRANS GP SS NPN 40V SOT23	MMBT2222ALT1G	ON Semi
3	R1,R2,R3	100	RES 100 OHM 1/10W 1% 0603 SMD	ERJ-3EKF1000V	Panasonic
3	R4,R6,R37	470	RES 470 OHM 1/10W 1% 0603 SMD	ERJ-3EKF4700V	Panasonic
4	R5,R7,R38,R40	332	RES 332 OHM 1/10W 1% 0603 SMD	ERJ-3EKF3320V	Panasonic
10	R8,R10,R13,R15,R22,R51,R53,R55,R58,R60	0	RES 0.0 OHM 1/10W JUMP 0603 SMD	ERJ-3GEY0R00V	Panasonic
4	R9,R11,R14,R16	DNI	DNI		
1	R12	DNI	RES 62 OHM 1/10W 1% 0402 SMD	ERJ-2RF62R0X	Panasonic
4	R17,R19,R21,R50	215K	RES 215K OHM 1/10W 1% 0603 SMD	ERJ-3EKF2153V	Panasonic
6	R18,R52,R54,R56,R57,R59	DNI	RES 0.0 OHM 1/10W JUMP 0603 SMD	ERJ-3GEY0R00V	Panasonic
1	R20	27K	RES 27K OHM 1/10W 1% 0402 SMD	ERJ-2RF2702X	Panasonic
4	R23,R26,R27,R28	10K	RES 10K OHM 1/10W 1% 0603 SMD	ERJ-3EKF1002V	Panasonic
2	R24,R25	27	RES 27 OHM 1/10W 1% 0603 SMD	ERJ-3EKF27R0V	Panasonic
1	R29	511K	RES 511K OHM 1/10W 1% 0603 SMD	ERJ-3EKF5113V	Panasonic
1	R30	100K	RES 100K OHM 1/10W 1% 0603 SMD	ERJ-3EKF1003V	Panasonic
2	R31,R45	2.7K	RES 2.7K OHM 1/10W 1% 0603 SMD	ERJ-3EKF2701V	Panasonic
1	R32,R34,R35,R39,R41,R46,R47,R48,R49,R73	10K	RES 10K OHM 1/10W 1% 0402 SMD	ERJ-2RF1002X	Panasonic
1	R33	100K	THERMISTOR 100K OHM NTC 0402 SMD	NCP15WF104F03RC	Murata Electronics
1	R36	DNI	RES 4.7K OHM 1/10W 1% 0402 SMD	ERJ-2RF4701X	Panasonic
2	R42,R43	0	RES 0.0 OHM 1/20W JUMP 0201 SMD	ERJ-1GNOR00C	Panasonic
7	R44,R67,R68,R69,R70,R71,R74	0	RES 0.0 OHM 1/10W JUMP 0402 SMD	ERJ-2GEOR00X	Panasonic
7	R61,R62,R63,R64,R65,R66,R75	DNI	RES 0.0 OHM 1/10W JUMP 0402 SMD	ERJ-2GEOR00X	Panasonic
1	R76	1M	RES SMD 1M OHM 5% 1/8W 0805	ERJ-6GEY1105V	Panasonic

MAX32625/MAX32626
Evaluation Kits

Evaluate: MAX32625, MAX32626

MAX32625/MAX32626 EV Kit Bill of Materials (continued)

QTY	PART	VALUE	BOM DESCRIPTION	MANUFACTURER_PN	MANUFACTURER
3	SW1,SW2,SW3	B35-1000	SWITCH TACTILE SPST-NO 0.05A 24V	B35-1000	Omron Electronics
2	SW4,SW5	B35-1002 BY OMZ	SWITCH TACTILE SPST-NO 0.05A 24V	B35-1002 BY OMZ	Omron Electronics
4	SW6,SW7,SW8,SW9	DIP SW 6POS SMT	SWITCH DIP 6POS HALF PITCH SMD	TDA06H05B1R	C&K Components
1	T1	2450BL15B200	BALUN 2.4GHZ WIFI/BLUETOOTH	2450BL15B200E	Johanson Technology Inc
4	TP1,TP2,TP3,TP9	BLK	TEST POINT PC MULTI PURPOSE BLK	5011	Keystone Electronics
3	TP4,TP5,TP6	1P	CONN HEADER .100 SINGL STR 1POS	PEC01SAAN	Sullins
1	TP7	PRPL	TEST POINT PC MULTI PURPOSE PRPL	5129	Keystone Electronics
2	TP8,TP10	RED	TEST POINT PC MULTI PURPOSE RED	5010	Keystone Electronics
1	U1	74LVC2T45DC	TXRX TRANSLATING 3ST 8VSSOP	74LVC2T45DC,125	NXP Semiconductors
1	U2	MX25U12835FZ2I-10G	IC FLASH 128MBIT 104MHZ 8WSON	MX25U12835FZ2I-10G	Macronix International
1	U3	NHD-2.23-12832UCB3	LCD OLED GRAPHIC 128 X 32 BLUE	NHD-2.23-12832UCB3	Newhaven Display Intl
1	U4	EM9301V02LF24D+	BLE Controller without DCDC	EM9301V02LF24D+	EM Microelectronic
2	U5,U7	MAX3207EAUT+T	ESD PROT DIFF SOT23-6	MAX3207EAUT+T	Maxim Integrated
1	U6	FT230XS-R	IC USB SERIAL BASIC UART 16SSOP	FT230XS-R	FTDI
1	U8	MAX14690NEWX +	MAX14690 36P WLP	MAX14690NEWX +	Maxim Integrated
1	U9	MAX1806EUA18+	Low Dropout Linear Regulator	MAX1806EUA18+	Maxim Integrated
1	U10	MAX1806EUA33+	IC REG LDO 3.3V/ADI 0.5A 8UMAX	MAX1806EUA33+	Maxim Integrated
1	U11	74LVC8T245PW,118	TXRX 8BIT TRANSLATING 24TSSOP	74LVC8T245PW,118	NXP Semiconductors
1	XU1 (Exclusive to the MAX32625 EV Kit Bill of Materials)	MAX32625	MAX32625 Microcontroller	MAX32625IWY+	Maxim Integrated
1	XU1 (Exclusive to the MAX32626 EV Kit Bill of Materials)	SOCKET	63P SKT C15407	C15407	Ironwood Electronics, INC.
1	XU1 (Exclusive to the MAX32626 EV Kit Bill of Materials)	MAX32626	MAX32626 Microcontroller	MAX32626IWY+	Maxim Integrated
1	Y1	32.768KHz	CRYSTAL 32.768KHZ 6.0PF SMD	ABS07-32.768KHZ-6-T	Abracon Corp
1	Y2	26MHz	CRYSTAL 26MHZ 10PF SMD	ABM8-26.000MHZ-10-1-U-T	Abracon Corporation

MAX32625/MAX32626 Schematics

NOTES:

REV 2.0

- 1) Changed GPIO4_1 to GPIO4_0 because Bluetooth uses GPIO2_7 for its SPIM2 Slave Select and GPIO4_0 is SPIM2 cooresponding Slave Ready signal.
Changed the net names to BTLE_SR0 and BTLE_SSEL2_0.

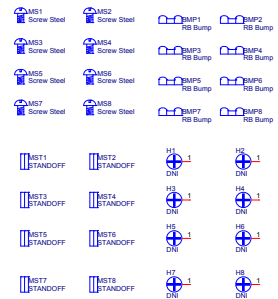

PCB1
PCB-00078-2-0

Copyright © 2015 - Maxim Integrated  maxim integrated

MAX32625/6 EV Kit - Rev History & Notes

Doc	Document Number	Rev
11517	SC-00078	2

Date: Tuesday, November 08, 2018 Sheet 1 of 7

Maxim cannot assume responsibility for use of any circuitry other than circuitry entirely embodied in a Maxim product. No circuit patent licenses are implied. Maxim reserves the right to change the circuitry and specifications without notice at any time.

MAX32625/MAX32626 Schematics (continued)

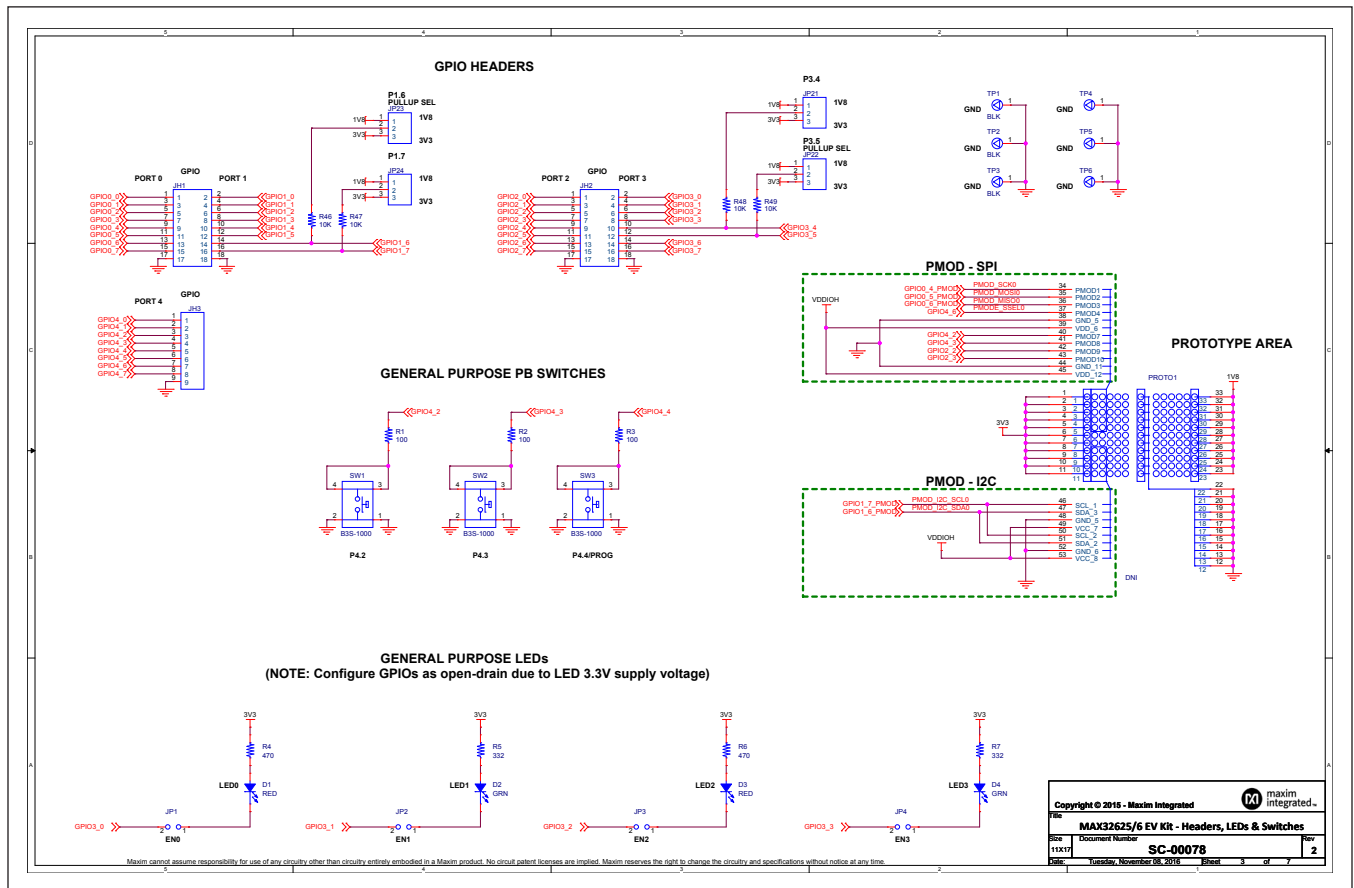

MAX32625/MAX32626 Schematics (continued)

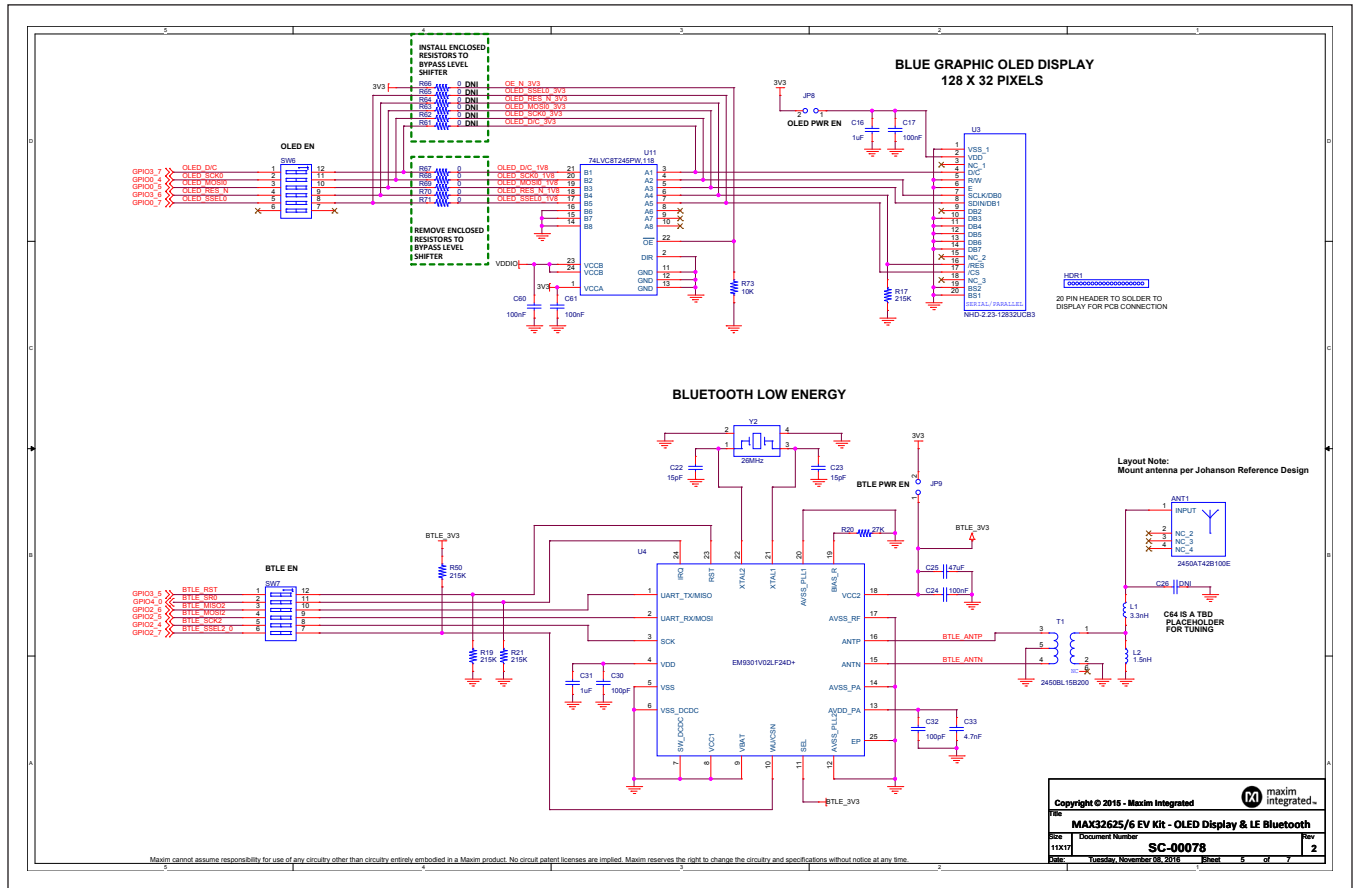

MAX32625/MAX32626 Schematics (continued)

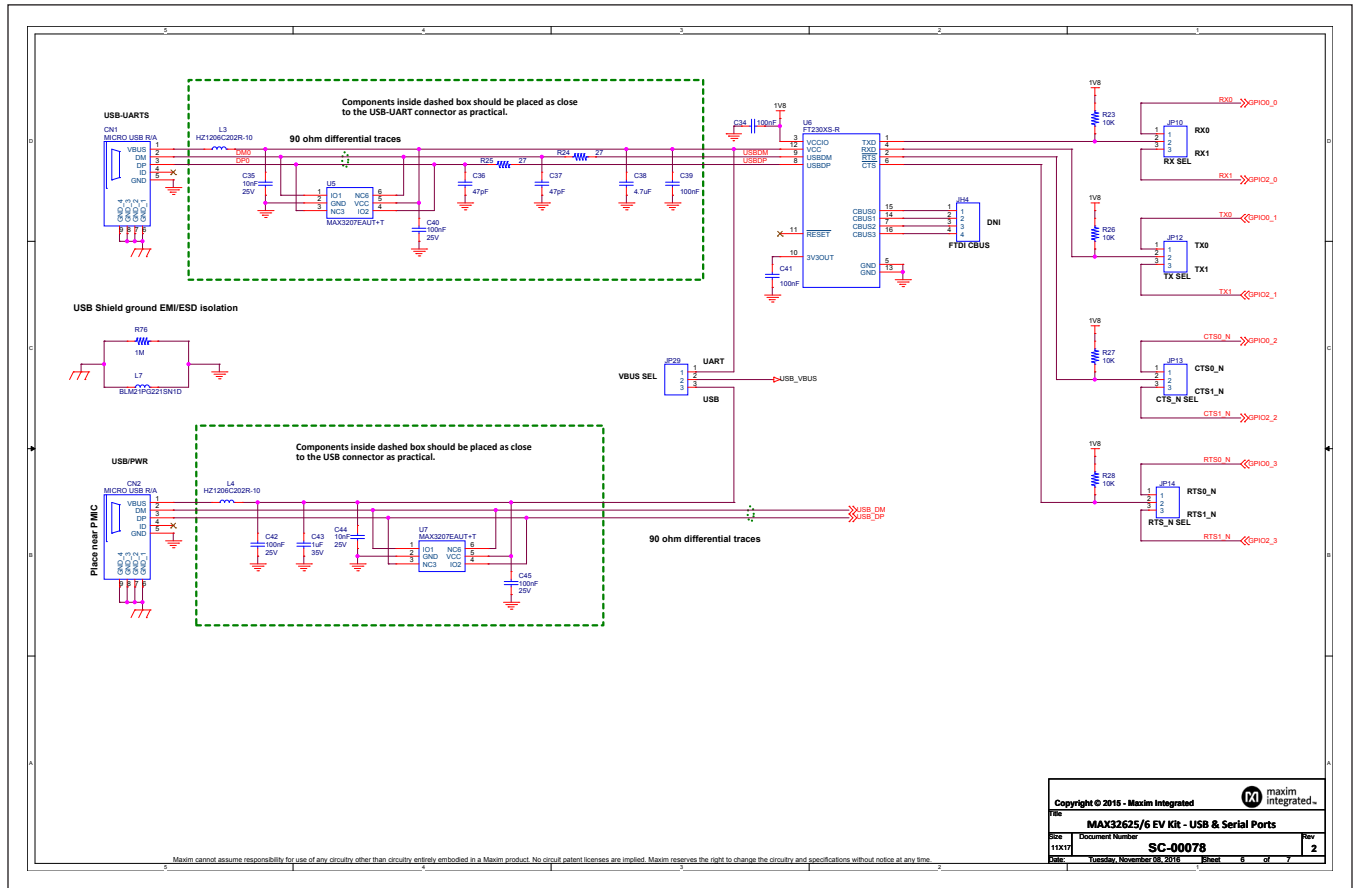

MAX32625/MAX32626 Schematics (continued)

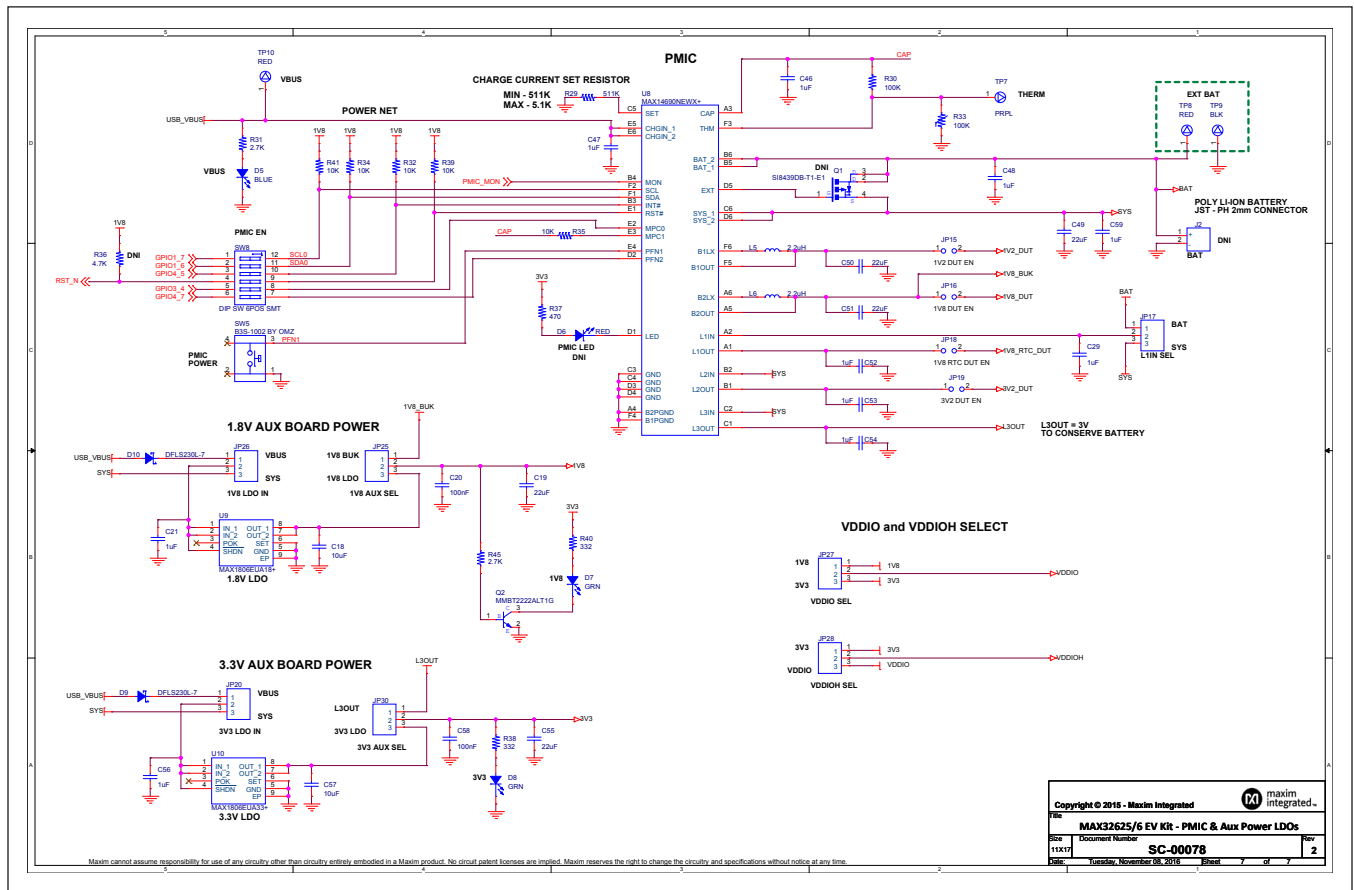

Revision History

REVISION NUMBER	REVISION DATE	DESCRIPTION	PAGES CHANGED
0	9/16	Initial release	—
1	11/16	Updated title, <i>General Description</i> , <i>EV Kit Contents, Benefits and Features</i> , first page photo, <i>Getting Started Detailed Description</i> , <i>Pushbuttons</i> , <i>USB</i> , <i>USB-UART Bridge</i> , <i>LEDs</i> , <i>Bluetooth Low-Energy (BLE) Controller</i> ; Figure 1, Figure 2, <i>Graphic OLED Display Module</i> , <i>GPIO Headers and Port Configuration</i> , <i>Additional Resources</i> , <i>Ordering Information</i> , <i>MAX32625/MAX32626 EV Kit Bill of Materials</i> , and <i>MAX32625/MAX32626 Schematics</i>	1–19

For pricing, delivery, and ordering information, please contact Maxim Direct at 1-888-629-4642, or visit Maxim Integrated's website at www.maximintegrated.com.

Maxim Integrated cannot assume responsibility for use of any circuitry other than circuitry entirely embodied in a Maxim Integrated product. No circuit patent licenses are implied. Maxim Integrated reserves the right to change the circuitry and specifications without notice at any time.