



Chipsmall Limited consists of a professional team with an average of over 10 year of expertise in the distribution of electronic components. Based in Hongkong, we have already established firm and mutual-benefit business relationships with customers from,Europe,America and south Asia,supplying obsolete and hard-to-find components to meet their specific needs.

With the principle of “Quality Parts,Customers Priority,Honest Operation,and Considerate Service”,our business mainly focus on the distribution of electronic components. Line cards we deal with include Microchip,ALPS,ROHM,Xilinx,Pulse,ON,Everlight and Freescale. Main products comprise IC,Modules,Potentiometer,IC Socket,Relay,Connector.Our parts cover such applications as commercial,industrial, and automotives areas.

We are looking forward to setting up business relationship with you and hope to provide you with the best service and solution. Let us make a better world for our industry!



Contact us

Tel: +86-755-8981 8866 Fax: +86-755-8427 6832

Email & Skype: info@chipsmall.com Web: www.chipsmall.com

Address: A1208, Overseas Decoration Building, #122 Zhenhua RD., Futian, Shenzhen, China





±15kV ESD-Protected, 2.5V, 1µA, 460kbps, RS-232 Compatible Transceivers

General Description

The MAX3316E–MAX3319E are 2.5V powered RS-232 compatible transceivers. These devices feature shutdown (MAX3317E), AutoShutdown Plus™ (MAX3318E/MAX3319E), and enhanced electrostatic discharge (ESD) protection integrated into the chip. All transmitter outputs and receiver inputs are protected to ±15kV using the IEC 1000-4-2 Air-Gap Discharge method, ±8kV using the IEC 1000-4-2 Contact Discharge method, and ±15kV using the Human Body Model.

All devices are guaranteed at a data rate of 460kbps. The transceivers have a proprietary low-dropout transmitter output stage enabling RS-232 compatible operation from a +2.25V to +3.0V supply with a dual charge pump. The charge pump requires only four 0.1µF capacitors. The MAX3318E/MAX3319E feature a logic-level output (READY) that asserts when the charge pump is regulating and the device is ready to begin transmitting.

The MAX3318E/MAX3319E achieve a 1µA supply current using Maxim's revolutionary AutoShutdown Plus feature. These devices automatically enter a low-power shutdown mode when the RS-232 cable is disconnected or the transmitters of the connected peripherals are inactive for more than 30 seconds. They turn on again when they sense a valid transition at any transmitter or receiver input. AutoShutdown Plus saves power without changes to the existing BIOS or operating system. The MAX3317E also features a 1µA shutdown mode that can be entered by driving SHDN low. The MAX3317E's receivers remain active while in shutdown mode, allowing external devices such as modems to be monitored using only 1µA supply current.

These devices are available in space-saving packages: MAX3316E (16-pin SSOP and 20-pin TSSOP), MAX3317E/MAX3318E (20-pin SSOP and 20-pin TSSOP), and MAX3319E (16-pin SSOP).

Applications

- Palmtop Computers
- Hand-Held Instruments
- Pagers
- Cellular Phones
- GPS
- Handy Terminals
- Hand-Held Electronic Books

Selector Guide and Typical Application Circuits appear at end of data sheet.

AutoShutdown Plus is a trademark of Maxim Integrated Products.



Features

- ◆ ESD Protection for RS-232 I/O Pins
 - ±15kV—Human Body Model
 - ±8kV—IEC 1000-4-2, Contact Discharge
 - ±15kV—IEC 1000-4-2, Air-Gap Discharge
- ◆ 300µA Operating Supply Current
- ◆ 1µA Low-Power Shutdown with Receivers Active
- ◆ Guaranteed 460kbps Data Rate
- ◆ Guaranteed 4V/µs Slew Rate
- ◆ RS-232 Compatible Down to 2.25V

Ordering Information

PART	TEMP. RANGE	PIN-PACKAGE
MAX3316ECUP	0°C to +70°C	20 TSSOP
MAX3316ECAE	0°C to +70°C	16 SSOP
MAX3316EEUP	-40°C to +85°C	20 TSSOP
MAX3316EEAE	-40°C to +85°C	16 SSOP
MAX3317ECUP	0°C to +70°C	20 TSSOP
MAX3317ECAP	0°C to +70°C	20 SSOP
MAX3317EEUP	-40°C to +85°C	20 TSSOP
MAX3317EEAP	-40°C to +85°C	20 SSOP
MAX3318ECUP	0°C to +70°C	20 TSSOP
MAX3318ECAP	0°C to +70°C	20 SSOP
MAX3318EEUP	-40°C to +85°C	20 TSSOP
MAX3318EEAP	-40°C to +85°C	20 SSOP
MAX3319ECAE	0°C to +70°C	16 SSOP
MAX3319EEAE	-40°C to +85°C	16 SSOP

Pin Configurations

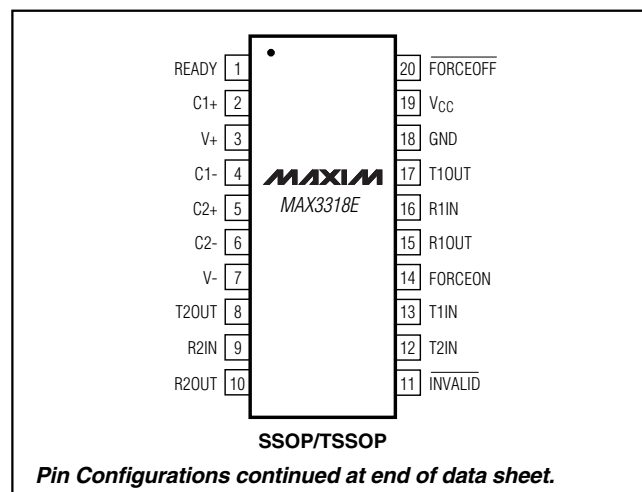

MAX3316E–MAX3319E

±15kV ESD-Protected, 2.5V, 1µA, 460kbps, RS-232 Compatible Transceivers

ABSOLUTE MAXIMUM RATINGS

V _{CC} to GND	-0.3V to +6V	Short-Circuit Duration, T _{OUT} to GND.....	Continuous
V+ to GND (Note 1)	-0.3V to +7V	Continuous Power Dissipation (T _A = +70°C)	
V- to GND (Note 1)	-7V to +0.3V	16-Pin SSOP (derate 7.14mW/°C above +70°C)	571mW
V+ + IV-I (Note 1)	+13V	20-Pin SSOP (derate 8.00mW/°C above +70°C)	640mW
Input Voltages		20-Pin TSSOP (derate 7.00mW/°C above +70°C)	559mW
T _{IN} , $\overline{\text{EN}}$, $\overline{\text{SHDN}}$, FORCEON,		Operating Temperature Range	
$\overline{\text{FORCEOFF}}$ to GND	-0.3V to +6V	MAX331_EC_	0°C to +70°C
R _{IN} to GND	±25V	MAX331_EE_	-40°C to +85°C
Output Voltages		Storage Temperature Range	-65°C to +150°C
T _{OUT} to GND.....	±13.2V	Lead Temperature (soldering, 10s)	+300°C
R _{OUT} , $\overline{\text{INVALID}}$, READY to GND	-0.3V to (V _{CC} + 0.3V)		

Note 1: V+ and V- can have maximum magnitudes of 7V, but their absolute difference cannot exceed 13V.

Stresses beyond those listed under "Absolute Maximum Ratings" may cause permanent damage to the device. These are stress ratings only, and functional operation of the device at these or any other conditions beyond those indicated in the operational sections of the specifications is not implied. Exposure to absolute maximum rating conditions for extended periods may affect device reliability.

ELECTRICAL CHARACTERISTICS

(V_{CC} = +2.25V to +3.0V, C1–C4 = 0.1µF, T_A = T_{MIN} to T_{MAX}, unless otherwise noted. Typical values are at V_{CC} = +2.5V, T_A = +25°C.)

PARAMETER	SYMBOL	CONDITIONS	MIN	TYP	MAX	UNITS
DC CHARACTERISTICS (V _{CC} = +2.5V, T _A = +25°C)						
AutoShutdown Plus Supply Current		FORCEON = GND, $\overline{\text{FORCEOFF}}$ = V _{CC} , all R _{IN} idle, all T _{IN} idle (MAX3318E/MAX3319E)		1	10	µA
Shutdown Supply Current		$\overline{\text{SHDN}}$ = GND (MAX3317E); $\overline{\text{FORCEOFF}}$ = GND (MAX3318E/MAX3319E)		1	10	µA
Supply Current		$\overline{\text{SHDN}}$ = V _{CC} , no load (MAX3317E); FORCEON = $\overline{\text{FORCEOFF}}$ = V _{CC} , no load (MAX3318E/MAX3319E)		0.3	1	mA
LOGIC INPUTS						
Input Logic Threshold Low		T _{IN} , $\overline{\text{EN}}$, $\overline{\text{SHDN}}$, FORCEON, $\overline{\text{FORCEOFF}}$		0.3 • V _{CC}		V
Input Logic Threshold High		T _{IN} , $\overline{\text{EN}}$, $\overline{\text{SHDN}}$, FORCEON, $\overline{\text{FORCEOFF}}$	0.7 • V _{CC}			V
Transmitter Input Hysteresis			0.3			V
Input Leakage Current		T _{IN} , $\overline{\text{EN}}$, $\overline{\text{SHDN}}$, FORCEON, $\overline{\text{FORCEOFF}}$	±0.01		±1	µA
RECEIVER OUTPUTS						
Output Leakage Current		$\overline{\text{EN}}$ = V _{CC} (MAX3317E), receivers disabled	±0.05		±10	µA
Output Voltage Low		I _{OUT} = 0.5mA	0.1 • V _{CC}			V
Output Voltage High		I _{OUT} = -0.5mA	0.9 • V _{CC}			V
RECEIVER INPUTS						
Input Voltage Range			-25		+25	V
Input Threshold Low		T _A = +25°C	0.3 • V _{CC}			V
Input Threshold High		T _A = +25°C	0.7 • V _{CC}			V
Input Hysteresis			0.3			V
Input Resistance		T _A = +25°C	3	5	7	kΩ
TRANSMITTER OUTPUTS						
Output Voltage Swing		All transmitter outputs loaded with 3kΩ to ground	±3.7	±4		V

±15kV ESD-Protected, 2.5V, 1μA, 460kbps, RS-232 Compatible Transceivers

MAX3316E-MAX3319E

ELECTRICAL CHARACTERISTICS (continued)

(V_{CC} = +2.25V to +3.0V, C1-C4 = 0.1μF, T_A = T_{MIN} to T_{MAX}, unless otherwise noted. Typical values are at V_{CC} = +2.5V, T_A = +25°C.)

PARAMETER	SYMBOL	CONDITIONS	MIN	TYP	MAX	UNITS
Output Resistance		V _{CC} = 0, transmitter output = ±2V	300	10M		Ω
Output Short-Circuit Current				±25	±60	mA
Output Leakage Current		V _{CC} = 0 or 2.25V to 3.0V, V _{OUT} = ±12V, transmitters disabled			±25	μA
ESD PROTECTION						
R _{IN} , T _{OUT}		Human Body Model		±15		kV
		IEC 1000-4-2 Air-Gap Discharge method		±15		
		IEC 1000-4-2 Contact Discharge method		±8		
AutoShutdown Plus (FORCEON = GND, FORCEOFF = V _{CC}) (MAX3318E/MAX3319E)						
Receiver Input Threshold to <u>INVALID</u> Output High		Figure 4a	Positive threshold		2.7	V
			Negative threshold		-2.7	
Receiver Input Threshold to <u>INVALID</u> Output Low		Figure 4a	-0.3		0.3	V
<u>INVALID</u> , READY Output Voltage Low		I _{OUT} = 0.5mA			0.1 • V _{CC}	V
<u>INVALID</u> , READY Output Voltage High		I _{OUT} = -0.5mA	0.9 • V _{CC}			V
Receiver Positive or Negative Threshold to <u>INVALID</u> High	t _{INVH}	V _{CC} = 2.5V, Figure 4b		1		μs
Receiver Positive or Negative Threshold to <u>INVALID</u> Low	t _{INVL}	V _{CC} = 2.5V, Figure 4b		30		μs
Receiver or Transmitter Edge to Transmitters Enabled	t _{WU}	V _{CC} = 2.5V, Figure 4b (Note 2)		100		μs
Receiver or Transmitter Edge to Transmitters Shutdown	t _{AUTO-SHDN}	V _{CC} = 2.5V, Figure 4b (Note 2)	15	30	60	s

TIMING CHARACTERISTICS

(V_{CC} = +2.25V to +3.0V, C1-C4 = 0.1μF, T_A = T_{MIN} to T_{MAX}, unless otherwise noted. Typical values are at V_{CC} = +2.5V, T_A = +25°C.)

PARAMETER	SYMBOL	CONDITIONS	MIN	TYP	MAX	UNITS
Maximum Data Rate		R _L = 3kΩ, C _L = 1000pF, one transmitter switching	460			kbps
Receiver Propagation Delay	t _{PHL}	R _{IN} to R _{OUT} , C _L = 150pF		0.175		μs
	t _{PLH}			0.175		
Receiver Output Enable Time		Normal operation (MAX3317E)		250		ns
Receiver Output Disable Time		Normal operation (MAX3317E)		250		ns
Transmitter Skew	t _{PHL} - t _{PLH}	(Note 3)		100		ns
Receiver Skew	t _{PHL} - t _{PLH}			50		ns

±15kV ESD-Protected, 2.5V, 1µA, 460kbps, RS-232 Compatible Transceivers

TIMING CHARACTERISTICS (continued)

($V_{CC} = +2.25V$ to $+3.0V$, $C_1-C_4 = 0.1\mu F$, $T_A = T_{MIN}$ to T_{MAX} , unless otherwise noted. Typical values are at $V_{CC} = +2.5V$, $T_A = +25^\circ C$.)

PARAMETER	SYMBOL	CONDITIONS	MIN	TYP	MAX	UNITS
Transition-Region Slew Rate		$V_{CC} = 2.5V$, $T_A = +25^\circ C$, $R_L = 3k\Omega$ to $7k\Omega$, measured from $+3V$ to $-3V$ or $-3V$ to $+3V$, $C_L = 150pF$ to $2500pF$	4		30	V/ μs

Note 2: A transmitter/receiver edge is defined as a transition through the transmitter/receiver input logic thresholds.

Note 3: Transmitter skew is measured at the transmitter zero crosspoints.

Typical Operating Characteristics

($V_{CC} = +2.5V$, $C_1-C_4 = 0.1\mu F$, 460kbps data rate, all transmitters loaded with $3k\Omega$, $T_A = +25^\circ C$, unless otherwise noted.)

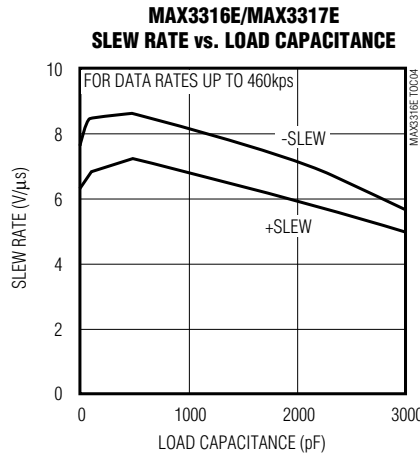
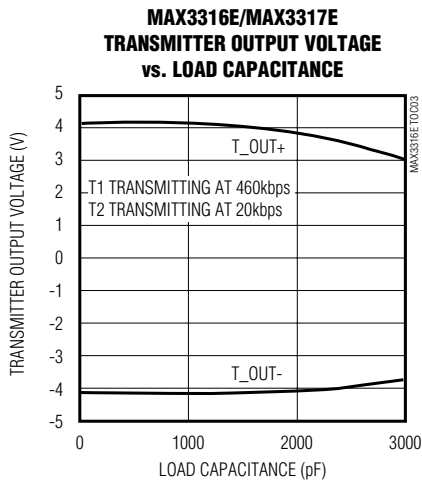
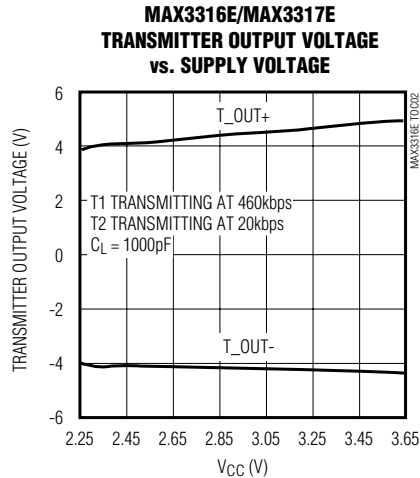
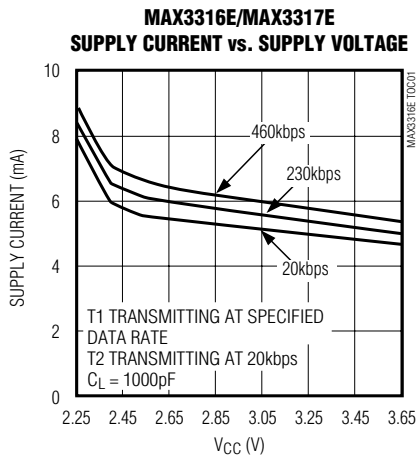

±15kV ESD-Protected, 2.5V, 1µA, 460kbps, RS-232 Compatible Transceivers

Typical Operating Characteristics (continued)

(V_{CC} = +2.5V, C₁–C₄ = 0.1µF, 460kbps data rate, all transmitters loaded with 3kΩ, T_A = +25°C, unless otherwise noted.)

**MAX3316E/MAX3317E
OPERATING SUPPLY CURRENT
vs. LOAD CAPACITANCE**

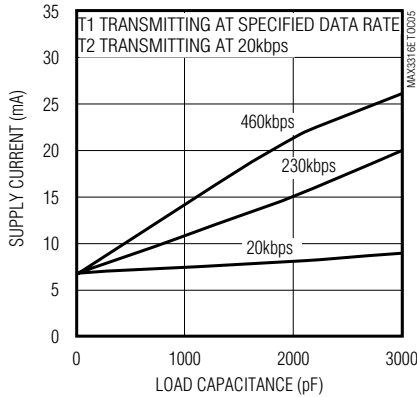

**MAX3318E/MAX3319E
SUPPLY CURRENT vs. SUPPLY VOLTAGE**

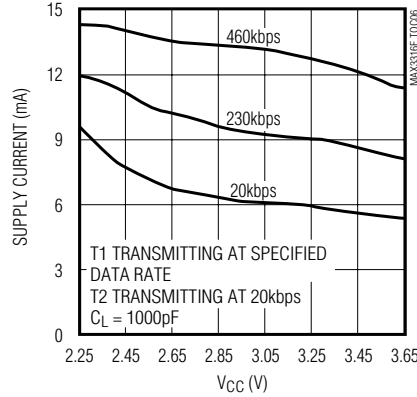

**MAX3318E/MAX3319E
TRANSMITTER OUTPUT VOLTAGE
vs. SUPPLY VOLTAGE**

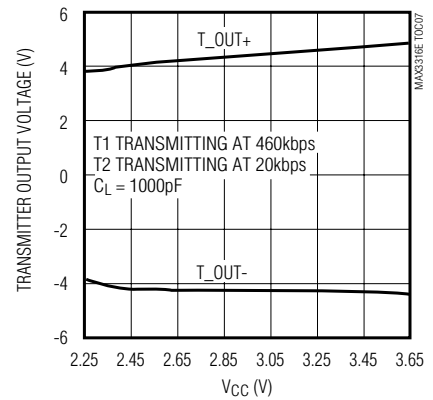

**MAX3318E/MAX3319E
TRANSMITTER OUTPUT VOLTAGE
vs. LOAD CAPACITANCE**

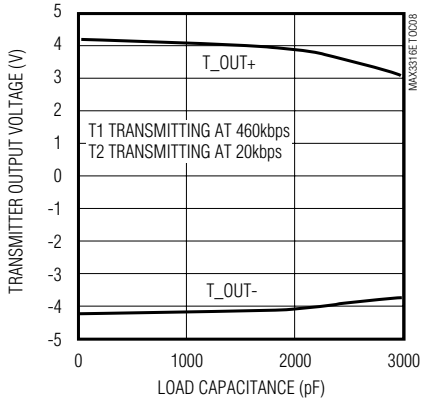

**MAX3318E/MAX3319E
SLEW RATE vs. LOAD CAPACITANCE**

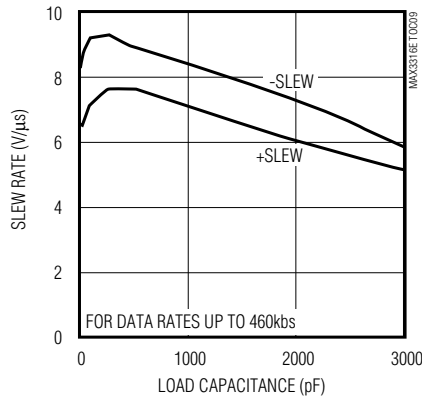

**MAX3318E/MAX3319E
OPERATING SUPPLY CURRENT
vs. LOAD CAPACITANCE**

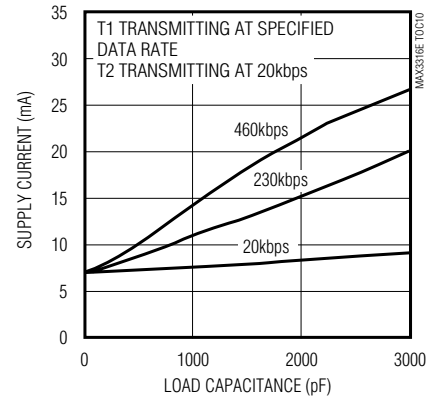

MAX3316E-MAX3319E

±15kV ESD-Protected, 2.5V, 1µA, 460kbps, RS-232 Compatible Transceivers

Typical Operating Characteristics (continued)

(V_{CC} = +2.5V, C1–C4 = 0.1µF, 460kbps data rate, all transmitters loaded with 3kΩ, T_A = +25°C, unless otherwise noted.)

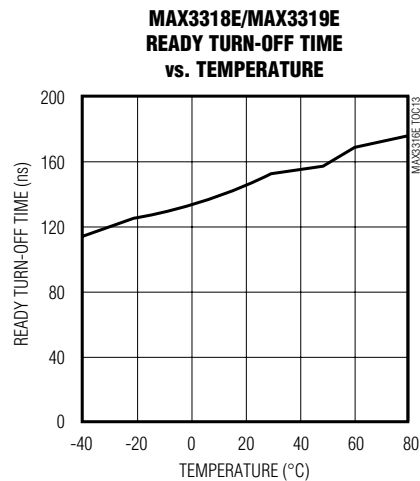
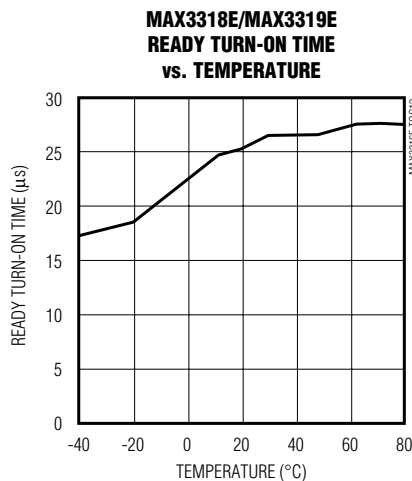
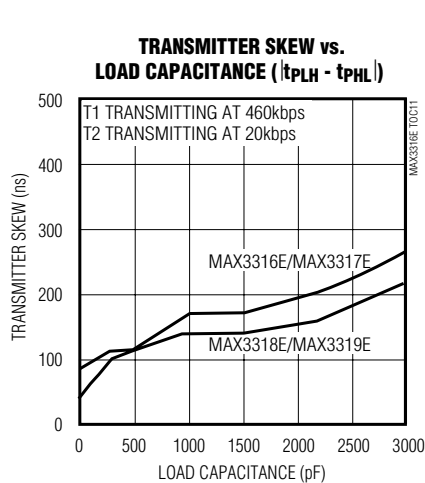

Pin Description

PIN					NAME	FUNCTION
MAX3316E		MAX3317E	MAX3318E	MAX3319E		
SSOP	TSSOP					
1	2	2	2	2	C1+	Positive Terminal of Voltage-Doubler Charge-Pump Capacitor
2	3	3	3	3	V+	+2 · V _{CC} Generated by the Charge Pump
3	4	4	4	4	C1-	Negative Terminal of Voltage-Doubler Charge-Pump Capacitor
4	5	5	5	5	C2+	Positive Terminal of Inverting Charge-Pump Capacitor
5	6	6	6	6	C2-	Negative Terminal of Inverting Charge-Pump Capacitor
6	7	7	7	7	V-	-2 · V _{CC} Generated by the Charge Pump
7, 14	8, 17	8, 17	8, 17	13	T_OUT	RS-232 Transmitter Outputs
8, 13	9, 16	9, 16	9, 16	8	R_IN	RS-232 Receiver Inputs
9, 12	12, 15	10, 15	10, 15	9	R_OUT	CMOS Receiver Outputs
10, 11	13, 14	12, 13	12, 13	11	T_IN	CMOS Transmitter Inputs
15	18	18	18	14	GND	Ground
16	19	19	19	15	V _{CC}	+2.25V to +3.0V Single-Supply Voltage
—	—	1	—	—	$\overline{\text{EN}}$	Receiver Enable, Active Low
—	1, 10, 11, 20	11, 14	—	—	N.C.	No Connection

±15kV ESD-Protected, 2.5V, 1µA, 460kbps, RS-232 Compatible Transceivers

MAX3316E-MAX3319E

Pin Description (continued)

		PIN			NAME	FUNCTION
MAX3316E		MAX3317E	MAX3318E	MAX3319E		
SSOP	TSSOP					
—		20	—	—	$\overline{\text{SHDN}}$	Shutdown Control, Active Low
—		—	1	1	READY	Ready to Transmit Output, Active High. READY is enabled high when V- goes below -3.5V and the device is ready to transmit.
—		—	11	10	$\overline{\text{INVALID}}$	Valid Signal Detector Output, Active Low. A logic high indicates that a valid RS-232 level is present on a receiver input.
—		—	14	12	FORCEON	Force-On Input, Active High. Drive high to override AutoShutdown Plus, keeping transmitters and receivers on (FORCEOFF must be high) (Table 1).
—		—	20	16	$\overline{\text{FORCEOFF}}$	Force-Off Input, Active Low. Drive low to shut down transmitters, receivers, and charge pump. This overrides AutoShutdown Plus and FORCEON (Table 1).

Detailed Description

Dual Charge-Pump Voltage Converter

The MAX3316E–MAX3319Es' internal power supply consists of a regulated dual charge pump that provides output voltages of +4.4V (doubling charge pump) and -4.3V (inverting charge pump), over the +2.25V to +3.0V range. The charge pump operates in discontinuous mode: if the output voltages are less than 4.4V, the charge pump is enabled; if the output voltages exceed 4.4V, the charge pump is disabled. Each charge pump requires a flying capacitor (C1, C2) and a reservoir capacitor (C3, C4) to generate the V+ and V- supplies.

The READY output (MAX3318E/MAX3319E) is low when the charge pumps are disabled in shutdown mode. The READY signal asserts high when V- goes below -2.75V.

RS-232 Compatible Transmitters

The MAX3316E–MAX3319Es' transmitters are inverting level translators that convert CMOS-logic levels to RS-232 compatible voltage levels. They guarantee a 460kbps data rate with worst-case loads of 3kΩ in parallel with 1000pF, providing compatibility with PC-to-PC communication software (such as LapLink™).

The MAX3317E's transmitters are turned off (high impedance) when $\overline{\text{SHDN}}$ is asserted low, putting the device in shutdown mode. The MAX3318E/MAX3319Es'

transmitters are turned off (high impedance) when $\overline{\text{FORCEOFF}}$ is asserted low, or when the AutoShutdown Plus circuitry senses that all receiver and transmitter inputs are inactive for more than 30 seconds.

The transmitter outputs can be driven to ±12V when power is off. The transmitter inputs do not have internal pull-up resistors. Connect unused inputs to GND or VCC.

RS-232 Receivers

The MAX3316E–MAX3319Es' receivers convert ±3.7V to ±13.2V RS-232 signal levels into CMOS-logic output levels. The receivers are rated to receive signals up to ±25V. The MAX3316E/MAX3318E/MAX3319Es' receivers feature inverting outputs that always remain active (Table 1). The MAX3317E's receivers have inverting, three-state outputs. In shutdown, the receivers can be active or inactive (Table 2).

The MAX3318E/MAX3319E feature an $\overline{\text{INVALID}}$ output that is asserted low when no valid RS-232 voltage levels have been detected on all receiver inputs. Because $\overline{\text{INVALID}}$ indicates the receiver's input condition, it is independent of the states of FORCEON and $\overline{\text{FORCEOFF}}$.

MAX3317E Shutdown Mode

Supply current falls to less than 1µA in shutdown mode (SHDN = low). When shut down, the device's charge pumps are turned off, V+ is pulled down to VCC, V- is pulled to ground, and the transmitter outputs are disabled (high impedance). The time required to exit shut-

LapLink is a trademark of Traveling Software.

±15kV ESD-Protected, 2.5V, 1µA, 460kbps, RS-232 Compatible Transceivers

Table 1. Output Control Truth Table (MAX3318E/MAX3319E)

OPERATION STATUS	FORCEON	$\overline{\text{FORCEOFF}}$	VALID RECEIVER LEVEL	RECEIVER OR TRANSMITTER EDGE WITHIN 30s	T_OUT	R_OUT
Shutdown (Forced Off)	X	0	X	X	High-Z	Active
Normal Operation (Forced On)	1	1	X	X	Active	Active
Normal Operation (AutoShutdown Plus)	0	1	X	Yes	Active	Active
Shutdown (AutoShutdown Plus)	0	1	X	No	High-Z	Active
Normal Operation	$\overline{\text{INVALID}}^*$	1	Yes	X	Active	Active
Normal Operation	$\overline{\text{INVALID}}^*$	1	X	Yes	Active	Active
Shutdown	$\overline{\text{INVALID}}^*$	1	No	No	High-Z	Active
Normal Operation (AutoShutdown)	$\overline{\text{INVALID}}^{**}$	$\overline{\text{INVALID}}^{**}$	Yes	X	Active	Active
Shutdown (AutoShutdown)	$\overline{\text{INVALID}}^{**}$	$\overline{\text{INVALID}}^{**}$	No	X	High-Z	Active

X = Don't care

* $\overline{\text{INVALID}}$ connected to FORCEON

** $\overline{\text{INVALID}}$ connected to FORCEON and $\overline{\text{FORCEOFF}}$

Table 2. Shutdown and Enable Control Truth Table (MAX3317E)

SHDN	$\overline{\text{EN}}$	T_OUT	R_OUT
0	0	High-Z	Active
0	1	High-Z	High-Z
1	0	Active	Active
1	1	Active	High-Z

down is typically 30µs, as shown in Figure 2. Connect SHDN to V_{CC} if the shutdown mode is not used; SHDN has no effect on R_OUT.

MAX3318E/MAX3319E AutoShutdown Plus Mode

Maxim's AutoShutdown Plus feature on the MAX3318E/MAX3319E allows the supply current to fall to 1µA. These devices will enter the AutoShutdown Plus mode if $\overline{\text{FORCEOFF}}$ is high, FORCEON is low, and they do not

sense a valid signal transition on any receiver or transmitter input for 30 seconds. This may occur if the RS-232 cable is disconnected or if the peripheral transmitters are turned off, and the UART driving the transmitter inputs is inactive. The system turns on again when a valid transition is applied to any RS-232 receiver or transmitter input. As a result, the system saves power without changes to the existing BIOS or operating system.

Figure 4a depicts valid and invalid RS-232 receiver voltage levels. $\overline{\text{INVALID}}$ indicates the receiver input's condition and is independent of FORCEON and $\overline{\text{FORCEOFF}}$ states. Figure 3 and Table 1 summarize the operating modes of the MAX3318E/MAX3319E. FORCEON and $\overline{\text{FORCEOFF}}$ override AutoShutdown Plus circuitry. When neither control is asserted, the IC selects between these states automatically based on the last receiver or transmitter edge received.

When shut down, the device's charge pumps turn off, V₊ is pulled to V_{CC}, V₋ is pulled to ground, the transmitter outputs are high impedance, and READY is driven low. The time required to exit shutdown is typically 30µs (Figure 2).

±15kV ESD-Protected, 2.5V, 1μA, 460kbps, RS-232 Compatible Transceivers

MAX3316E-MAX3319E

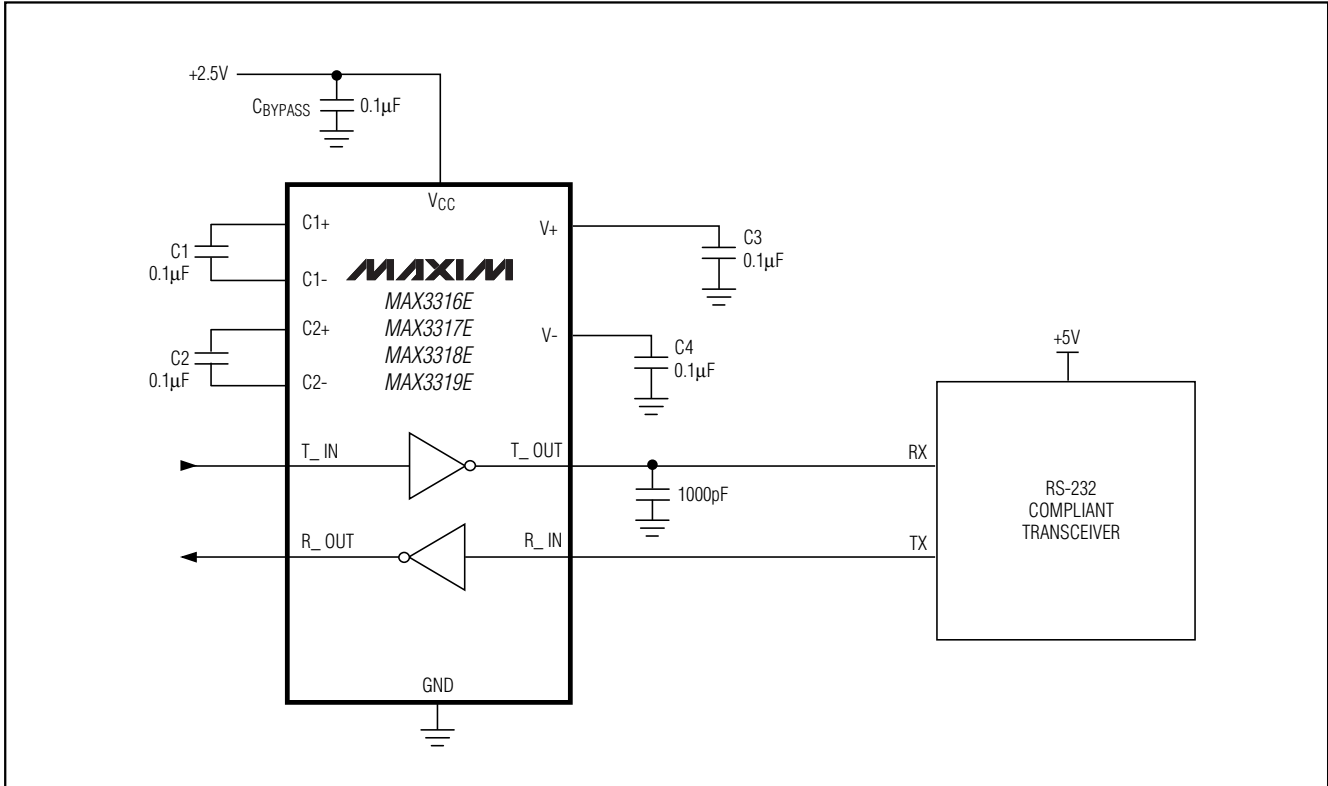

Figure 1a. RS-232 Compatibility Circuit

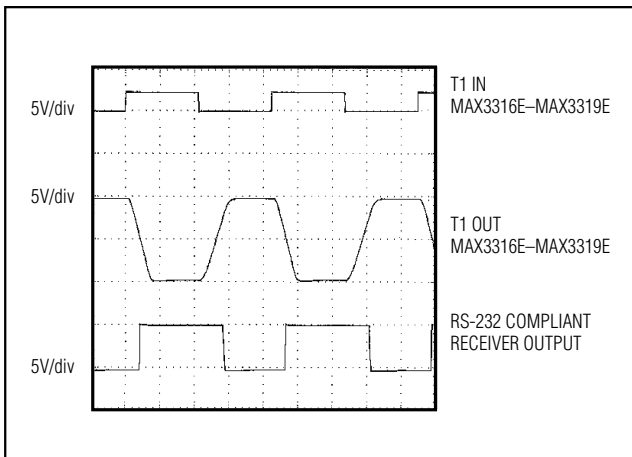

Figure 1b. MAX3316E-MAX3319E Transmitter Output Compatibility with an RS-232 Receiver

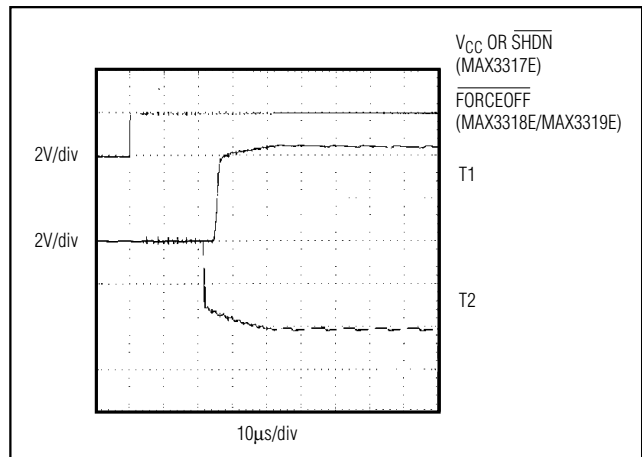

Figure 2. Transmitter Outputs when Exiting Shutdown or Powering Up

±15kV ESD-Protected, 2.5V, 1µA, 460kbps, RS-232 Compatible Transceivers

By connecting FORCEON to $\overline{\text{INVALID}}$, the MAX3318E/MAX3319E shut down when no valid receiver level is detected and wake up when a valid receiver level is detected.

A system with AutoShutdown Plus may need time to wake up. Figure 5 shows a circuit that forces the transmitters on for 100ms, allowing enough time for the other system to realize that the MAX3318E/MAX3319E is awake. If the other system outputs valid RS-232 signal transitions within that time, the RS-232 ports on both systems remain enabled.

Connecting to the PC (MAX3318E/MAX3319E)

If direct software control is desired, use $\overline{\text{INVALID}}$ to indicate DTR or ring indicator (RI) signal. This can be used to connect a hand-held device to a PC. One example is using the Hot Sync™ function on a personal digital assistant (PDA). The transmitter and receiver signals (T_OUT and R_IN) are used for communication, while $\overline{\text{INVALID}}$ causes a change of state on RI. The change of state on RI will trigger an interrupt on the PC and allow communication to begin between the device and the PC. This eliminates the need for the PC to poll constantly the receiver or transmitter lines to determine if the device is connected.

±15kV ESD Protection

All the pins on the MAX3316E-MAX3319E are protected against ESDs encountered during handling and assembly. The driver outputs and receiver inputs have extra protection against static electricity. Maxim's engineers have developed state-of-the-art structures to protect these pins against ESD of ±15kV without damage. The ESD structures withstand high ESD in all states: normal operation, shutdown, and powered down. After an ESD event, Maxim's E versions keep working without latchup, whereas competing products can latch and must be powered down to remove latchup.

ESD protection can be tested in various ways; the transmitter outputs and receiver inputs of the product family are characterized for protection to the following limits:

- ±15kV using the Human Body Model
- ±8kV using the IEC 1000-4-2 Contact Discharge method
- ±15kV using IEC 1000-4-2 Air-Gap method

ESD Test Conditions

ESD performance depends on a variety of conditions. Contact Maxim for a reliability report that documents test setup, test methodology, and test results.

Hot Sync is a trademark of 3Com.

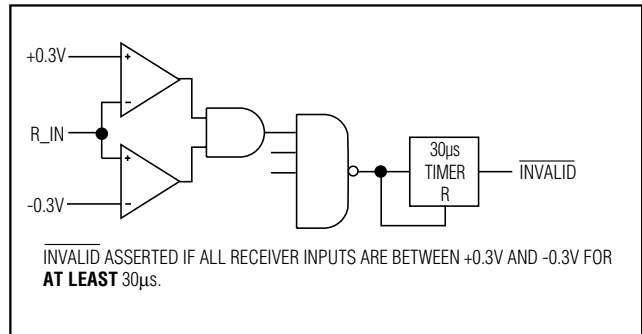

Figure 3a. $\overline{\text{INVALID}}$ Functional Diagram, $\overline{\text{INVALID}}$ Low

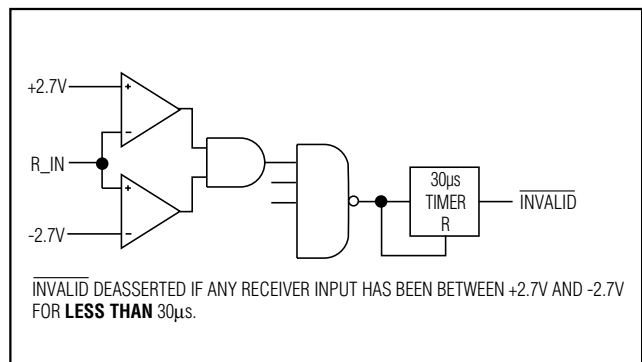

Figure 3b. $\overline{\text{INVALID}}$ Functional Diagram, $\overline{\text{INVALID}}$ High

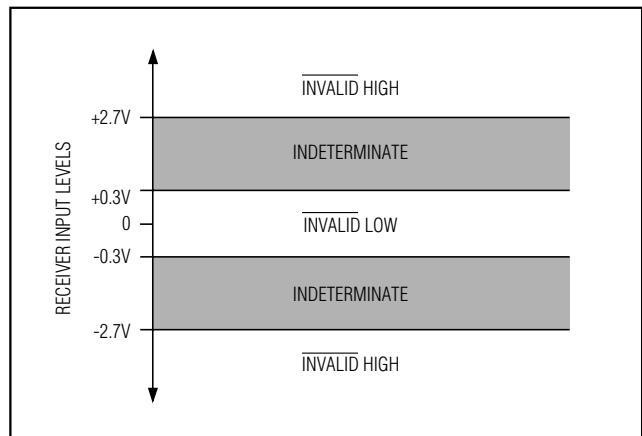

Figure 4a. Receiver Positive/Negative Thresholds for $\overline{\text{INVALID}}$

Human Body Model

Figure 6a shows the Human Body Model, and Figure 6b shows the current waveform it generates when discharged into low impedance. This model consists of a 100pF capacitor charged to the ESD voltage of interest, which is then discharged into the test device through a 1.5kΩ resistor.

±15kV ESD-Protected, 2.5V, 1μA, 460kbps, RS-232 Compatible Transceivers

MAX3316E-MAX3319E

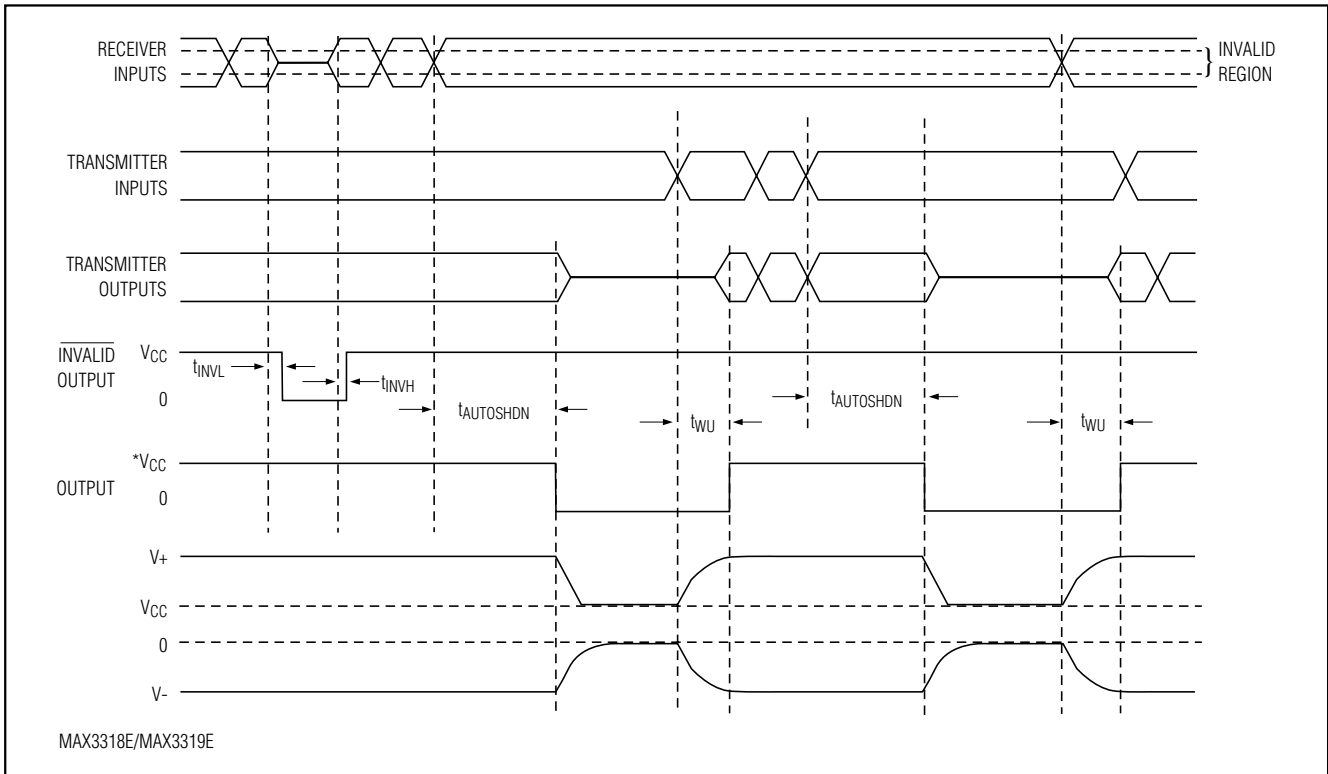

Figure 4b. AutoShutdown Plus, $\overline{\text{INVALID}}$, and READY Timing Diagram

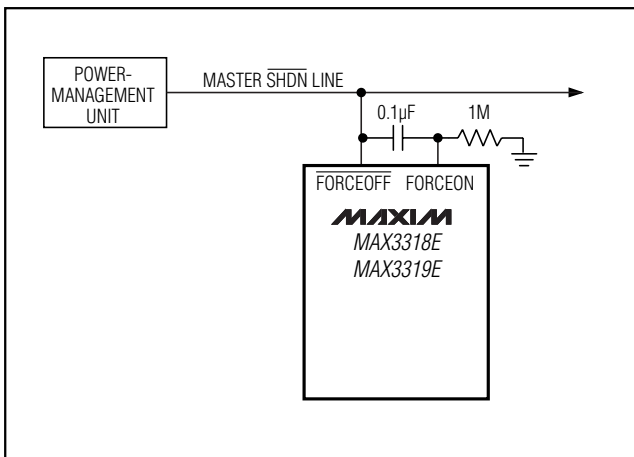

Figure 5. AutoShutdown Plus Initial Turn-On to Wake Up a Mouse or Another System

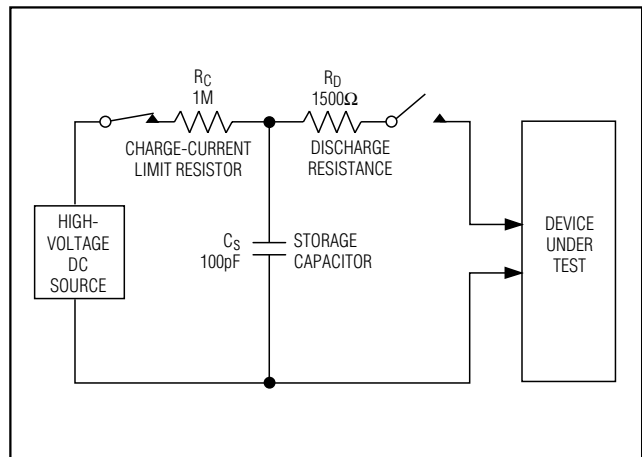

Figure 6a. Human Body ESD Test Model

±15kV ESD-Protected, 2.5V, 1μA, 460kbps, RS-232 Compatible Transceivers

IEC 1000-4-2

The IEC 1000-4-2 standard covers ESD testing and performance of finished equipment; it does not specifically refer to ICs. The MAX3316E-MAX3319E help you design equipment that meets Level 4 (the highest level) of IEC 1000-4-2 without the need for additional ESD-protection components.

The major difference between tests done using the Human Body Model and IEC 1000-4-2 is higher peak current in IEC 1000-4-2 because series resistance is lower in the IEC 1000-4-2 model. Hence, the ESD withstand voltage measured to IEC 1000-4-2 is generally lower than that measured using the Human Body Model. Figure 7a shows the IEC 1000-4-2 model, and Figure 7b shows the current waveform for the 8kV, IEC 1000-4-2, Level 4, ESD Contact Discharge test.

The Air-Gap Discharge test involves approaching the device with a charged probe. The Contact Discharge method connects the probe to the device before the probe is energized.

Machine Model

The Machine Model for ESD tests all pins using a 200pF storage capacitor and zero discharge resistance. Its objective is to emulate the stress caused by contact that occurs with handling and assembly during manufacturing. All pins require this protection during manufacturing, not just RS-232 inputs and outputs. Therefore, after PC board assembly, the Machine Model is less relevant to I/O ports.

Applications Information

RS-232 Compatible Operation

The MAX3316E-MAX3319E do not meet EIA-232 requirements for transmitter output voltage levels. EIA-232 compliance specifies transmitter output voltage swings of ±5V when loaded with 3kΩ and 2500pF.

The receiver inputs are fully EIA-232 compliant.

The MAX3316E-MAX3319E will function properly with most modern RS-232 interfaces. This allows RS-232 compatible communication in low-voltage systems without the added expense of a voltage tripler or switched-mode power supply.

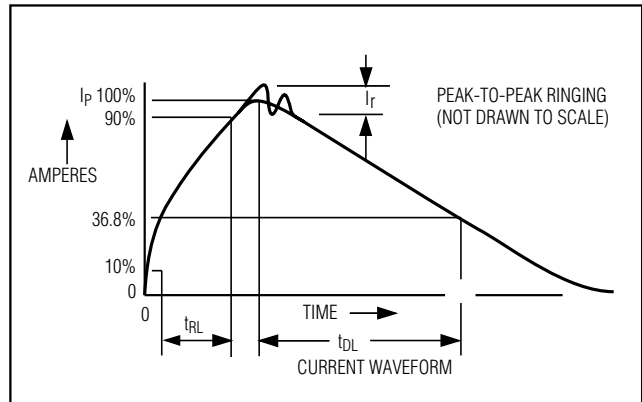

Figure 6b. Human Body Current Waveform

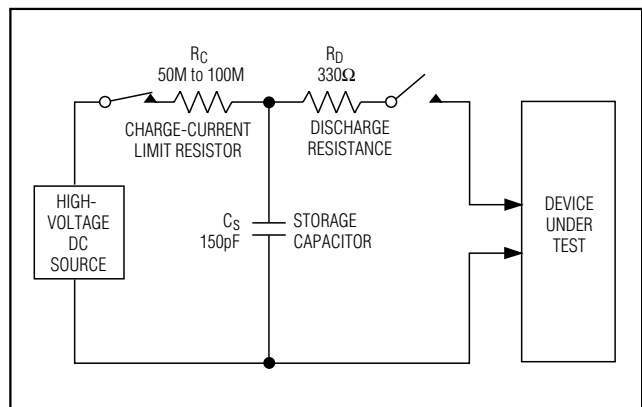

Figure 7a. IEC 1000-4-2 ESD Test Model

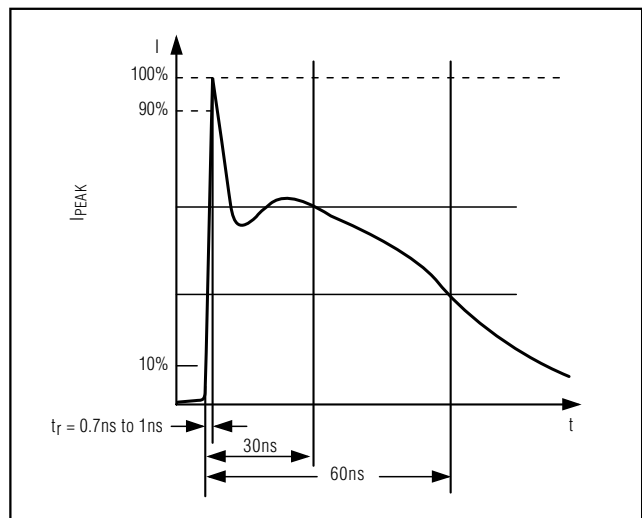

Figure 7b. IEC 1000-4-2 ESD Generator Current Waveform

±15kV ESD-Protected, 2.5V, 1μA, 460kbps, RS-232 Compatible Transceivers

MAX3316E-MAX3319E

Capacitor Selection

The capacitor type used for C1–C4 is not critical for proper operation; polarized or nonpolarized capacitors can be used. The charge pump requires 0.1μF capacitors. Increasing the capacitor values (e.g., by a factor of 2) reduces ripple on the transmitter outputs and slightly reduces power consumption. C2, C3, and C4 can be increased without changing C1's value. **However, do not increase C1 without also increasing the values of C2, C3, C4, and CBYPASS to maintain proper ratios (C1 to other capacitors).**

When using the minimum-required capacitor values, make sure the capacitor value does not degrade excessively with temperature. If in doubt, use capacitors with a higher nominal value. The capacitor's equivalent series resistance (ESR), which usually rises at low temperatures, influences the amount of ripple on V+ and V-.

Power-Supply Decoupling

In most circumstances, a 0.1μF bypass capacitor is adequate. In applications that are sensitive to power-supply noise, decouple VCC to ground with a capacitor of the same value as charge pump capacitor C1. Connect bypass capacitors as close to the IC as possible.

Transmitter Outputs when Exiting Shutdown

Figure 2 shows two transmitter outputs when exiting shutdown mode. As they become active, the two transmitter outputs are shown going to opposite RS-232 compatible levels (one transmitter input is high, the other is low). Each transmitter is loaded with 3kΩ in parallel with 2500pF. The transmitter outputs display no ringing or undesirable transients as they come out of shutdown. Note that the transmitters are enabled only when the magnitude of V- exceeds approximately -3V.

High Data Rates

The MAX3316E–MAX3319E maintain RS-232 compatible ±3.7V minimum transmitter output voltage even at high data rates. Figure 8 shows a transmitter loopback test circuit. Figure 9 shows a loopback test result at 230kbps. For Figure 9, all transmitters were driven simultaneously at 230kbps into EIA/TIA-562 loads in parallel with 1000pF.

Chip Information

TRANSISTOR COUNT: 1130

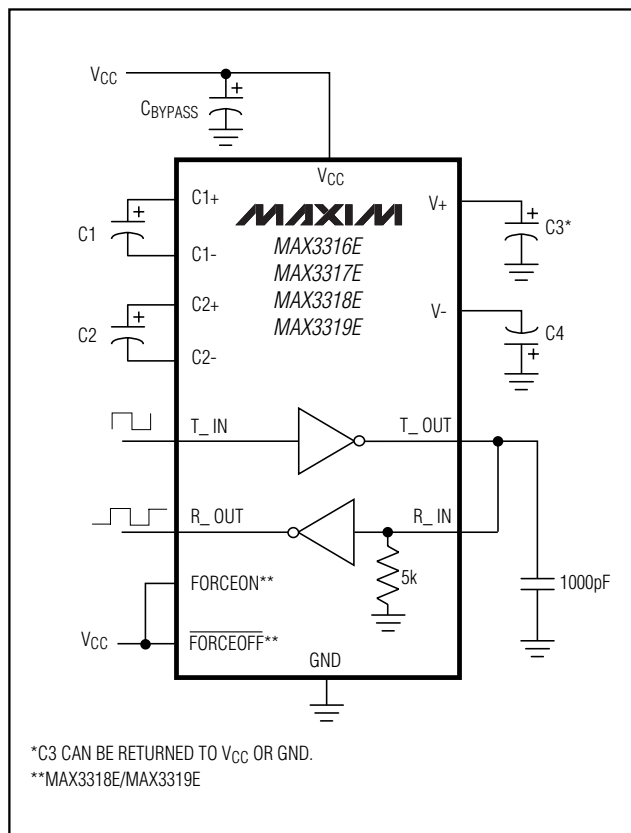

Figure 8. Loopback Test Circuit

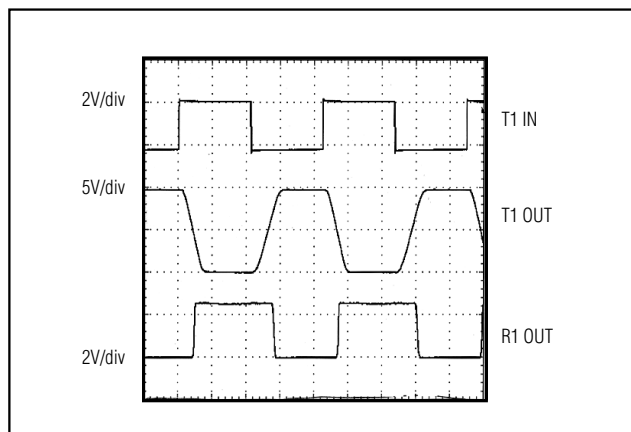
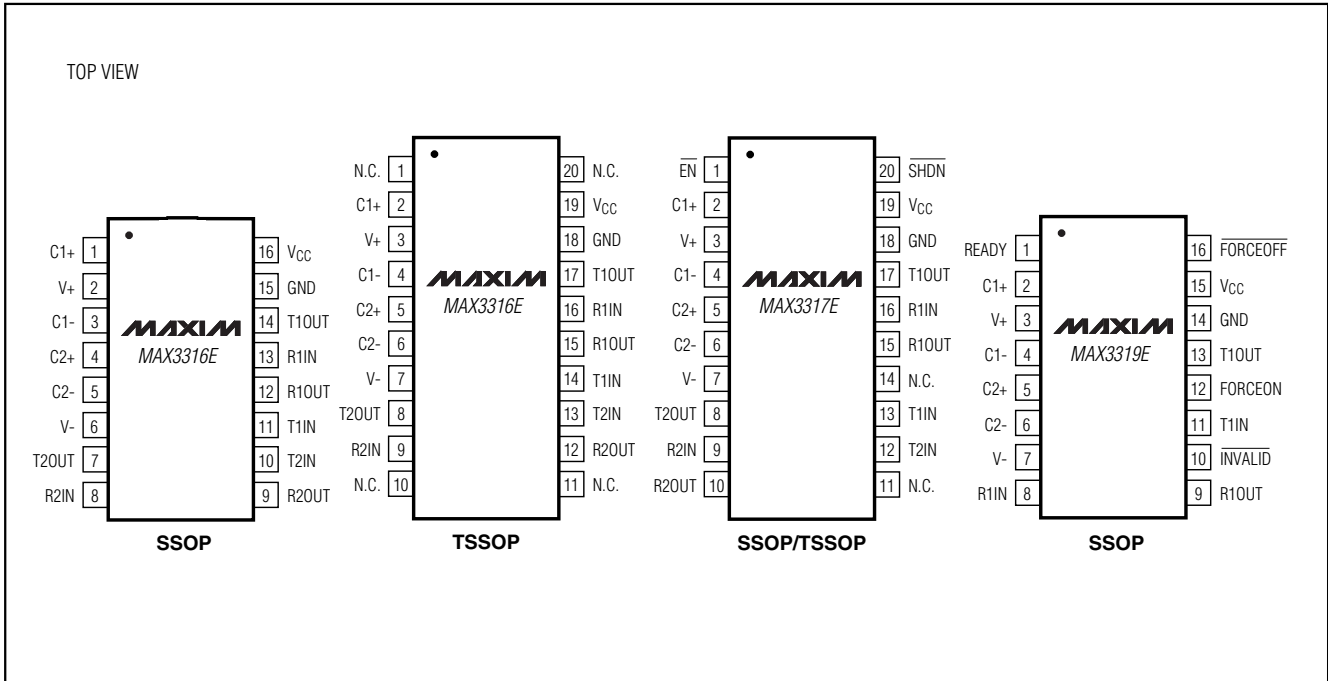

Figure 9. Loopback Test Result at 230kbps

$\pm 15\text{kV}$ ESD-Protected, 2.5V, 1 μA , 460kbps, RS-232 Compatible Transceivers

Pin Configurations (continued)



±15kV ESD-Protected, 2.5V, 1µA, 460kbps, RS-232 Compatible Transceivers

Selector Guide

PART	NO. OF DRIVERS/ RECEIVERS	GUARANTEED DATA RATE (kbps)	READY OUTPUT	SHUTDOWN	AutoShutdown Plus
MAX3316E	2/2	460	—	—	—
MAX3317E	2/2	460	—	✓	—
MAX3318E	2/2	460	✓	—	✓
MAX3319E	1/1	460	✓	—	✓

MAX3316E-MAX3319E

Typical Application Circuits

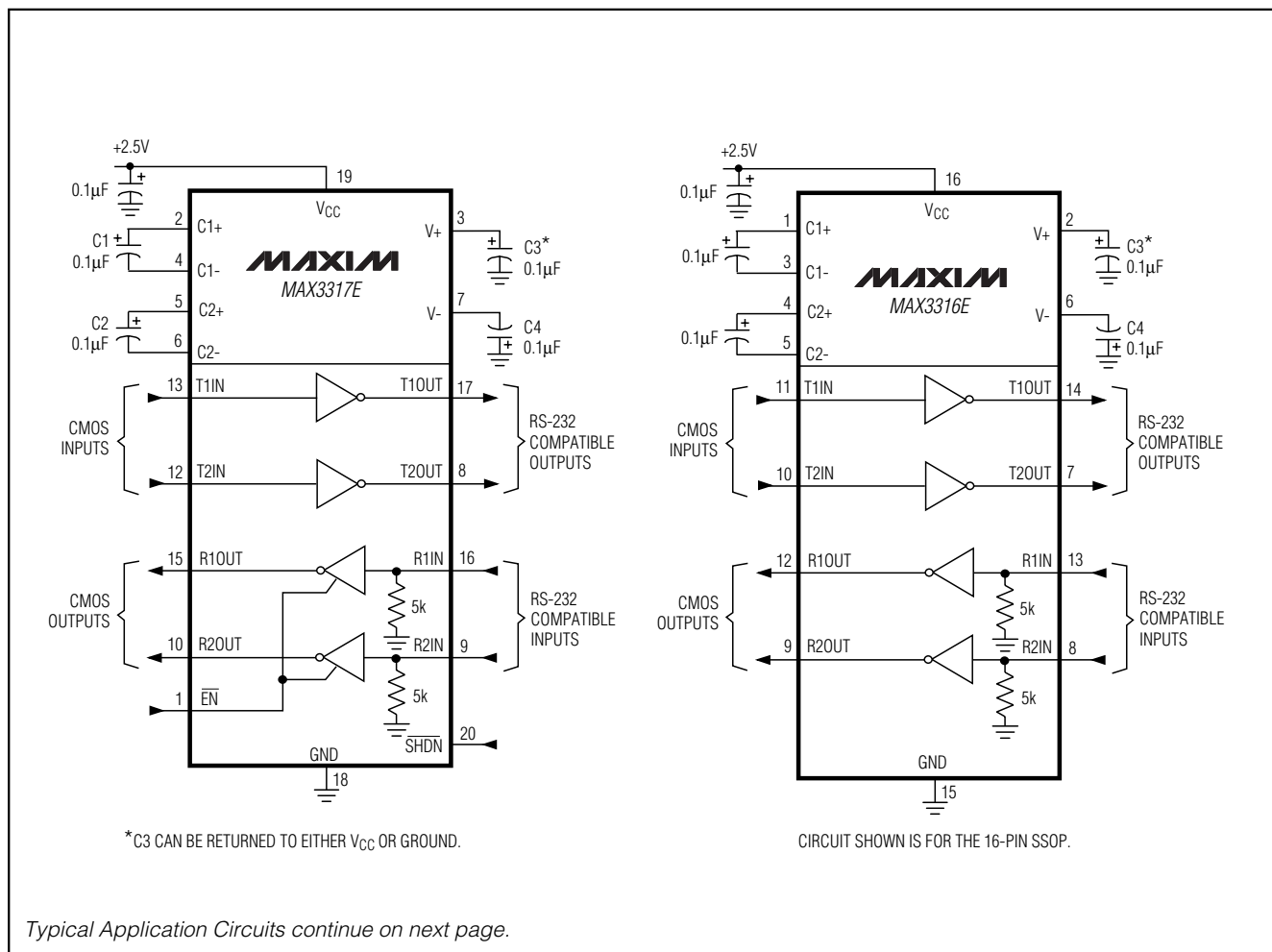

±15kV ESD-Protected, 2.5V, 1µA, 460kbps, RS-232 Compatible Transceivers

Typical Application Circuits (continued)

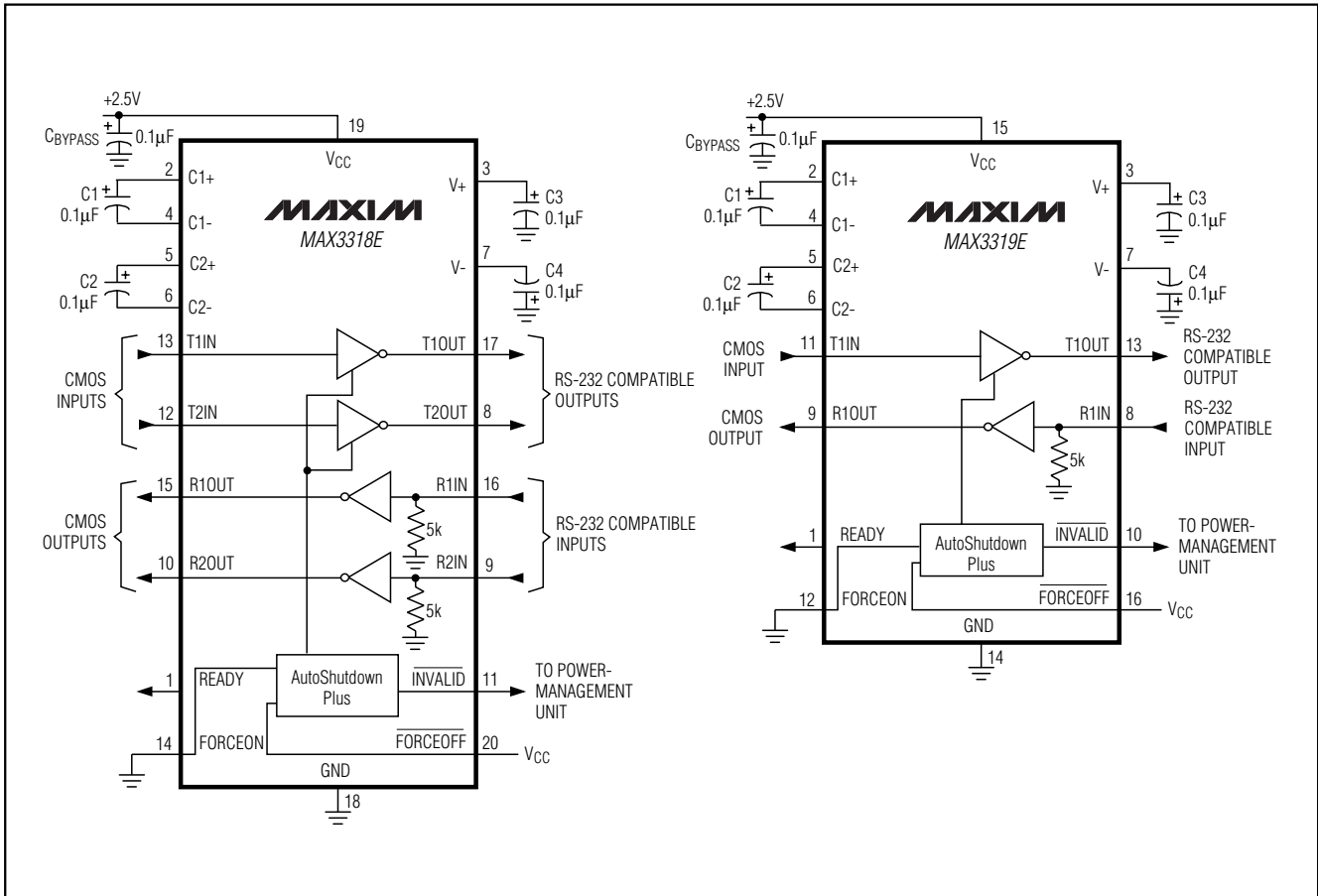

Maxim cannot assume responsibility for use of any circuitry other than circuitry entirely embodied in a Maxim product. No circuit patent licenses are implied. Maxim reserves the right to change the circuitry and specifications without notice at any time.

16 **Maxim Integrated Products, 120 San Gabriel Drive, Sunnyvale, CA 94086 408-737-7600**