



Chipsmall Limited consists of a professional team with an average of over 10 year of expertise in the distribution of electronic components. Based in Hongkong, we have already established firm and mutual-benefit business relationships with customers from,Europe,America and south Asia,supplying obsolete and hard-to-find components to meet their specific needs.

With the principle of “Quality Parts,Customers Priority,Honest Operation,and Considerate Service”,our business mainly focus on the distribution of electronic components. Line cards we deal with include Microchip,ALPS,ROHM,Xilinx,Pulse,ON,Everlight and Freescale. Main products comprise IC,Modules,Potentiometer,IC Socket,Relay,Connector.Our parts cover such applications as commercial,industrial, and automotives areas.

We are looking forward to setting up business relationship with you and hope to provide you with the best service and solution. Let us make a better world for our industry!



Contact us

Tel: +86-755-8981 8866 Fax: +86-755-8427 6832

Email & Skype: info@chipsmall.com Web: www.chipsmall.com

Address: A1208, Overseas Decoration Building, #122 Zhenhua RD., Futian, Shenzhen, China



MAXIM

MAX3654 Evaluation Kit

General Description

The MAX3654 evaluation kit (EV kit) is a factory-assembled printed circuit board (PCB) that provides two circuit versions—optical input and electrical input.

The optical circuit includes the photodiode bias circuitry, an op amp for feed-forward AGC operation, and a balun for single-ended 75Ω output. Through-hole pads are provided to attach a triplexer analog photodiode. It is important to select a photodiode with capacitance and inductance in the anode and cathode connections as symmetric as possible for optimum linearity.

The electrical circuit is normally configured with a 50Ω input for use with conventional test and measurement equipment and a 75Ω output. The 75Ω output can be connected to 50Ω test and measurement equipment using a minimum loss pad. If desired, the MAX3654 input can also provide a 75Ω input by replacing R12 and R13 with 25Ω resistors.

Features

- ◆ Fully Assembled and Tested
- ◆ Optical and Electrical Inputs
- ◆ Automatic Gain Control

Ordering Information

PART	TEMP RANGE	IC-PACKAGE
MAX3654EVKIT	-40°C to +85°C	16 QFN

Evaluation Component List

DESIGNATION	QTY	DESCRIPTION
C1, C2, C4, C5, C19–C22	8	0.001μF ±10% ceramic capacitors (0402)
C3, C7, C8, C9, C12, C16, C17, C23, C24, C27, C29	11	0.1μF ±5% ceramic capacitors (0603)
C6, C10, C11, C25, C26	5	1μF 10V, ±10% min ceramic capacitors
C13, C14, C28	3	33μF 10V, ±20% min tantalum capacitors
R6, R18	2	1.62kΩ ±1% resistors (0402)
R2	1	10Ω ±1% resistor (0402)
R3, R4, R5, R16, R17	6	100kΩ ±1% resistors (0402)
R1, R21	2	1kΩ ±1% resistors (0402)
R7, R19	2	2.43kΩ ±1% resistors (0402)
R9, R15	2	20kΩ ±1% resistors (0402)
R12, R13	2	12.1Ω ±1% resistors (0402)
R8, R20	2	6.04kΩ ±1% resistors (0402)
R22	1	open (0402)

DESIGNATION	QTY	DESCRIPTION
J2, J4	2	BNC 75Ω, Edge Mount Trompeter UCBJE20-1
J3	1	SMA connector, tab contact, Johnson, 142-0701-851
TP1–TP13	13	Test Points
JU1–JU3, JU5, JU6	5	2-pin headers, 0.1in centers
L1, L5	2	Bead, Murata BLM15HD182SN1 (0402)
L2, L6	2	10μH inductor, TDK MLF1608E100K (0603)
U1, U3	2	MAX3654ETE+
U2, U4	2	MAX4240EUK
U5	0	Photodiode not supplied
U6	1	Balun Pulse Engineering CX2039
U7, U8	2	Balun Pulse Engineering CX2038

MAX3654 Evaluation Kit

Component Suppliers

SUPPLIER	PHONE	WEBSITE
AVX	803-448-9411	www.avxcorp.com
Pulse Engineering	858-674-8100	www.pulseeng.com
Murata	770-436-1300	www.murata.com

Note: Please indicate that you are using the MAX3654 when contacting these component suppliers.

Quick Start

Optical Evaluation

- 1) Attach triplexer photodiode to IN+ and IN- of the MAX3654. The cathode normally connects to IN+. The photodiode case should be grounded to the most convenient ground via. Make certain that the anode and cathode leads are symmetric in length and orientation, lead lengths should normally be about 5mm.
- 2) Set JU2 to R4 to manually adjust the gain with an input from 0 to 1.4V on TP3.
- 3) Leave JU3 open for minimum hysteresis.
- 4) Set JU1 to R8 to enable the output signal.
- 5) Connect the signal output at J2 to a 75Ω spectrum-analyser input. A minimum loss pad may also be used to connect J2 to 50Ω test equipment.
- 6) Connect a +5V supply to the VCC terminal, TP1 and ground to the GND terminal, TP2.
- 7) Connect the photodiode bias supply to TP13. Typically use +12V bias supply, or as required by the photodiode.

Electrical Evaluation

- 1) Connect a 50Ω signal source to IN at J3. Set the input signal level to $P_{IN} = -18\text{dBm}$, so that the voltage on 50Ω produces the maximum input level of 1.6mA_{P-P}.
- 2) Connect the RF output at J4 to a 75Ω spectrum analyser input. A minimum loss pad may also be used to connect J4 to 50Ω test equipment.
- 3) Leave JU6 open for minimum hysteresis.
- 4) Set JU5 to R20 to enable output.

- 5) Connect a +5V supply to the VCC terminal, TP7 and ground to the GND terminal, TP8.
- 6) Apply 1.4V to TP12 to set the MAX3654 gain to minimum, 43.5dBΩ. A voltage from 0.175V to 1.4V at TP12 adjusts the gain from 62dBΩ to 43.5dBΩ

Input and Output Signal Levels

When used in the electrical input configuration shown in Figure 2, the MAX3654 is intended to operate with AC input signal current from 175μA_{P-P} to 1.6mA_{P-P}. The corresponding electrical input is -37dBm ($0 \leq V_{AGC} \leq 0.175\text{V}$) to -18dBm ($V_{AGC} = 1.4\text{V}$), on 50Ω. The MAX3654 EV Kit can also be configured to provide 75Ω input impedance by replacing R12 and R13 with 25Ω resistors.

When used in the optical input configuration shown in Figure 2, JU2 may be connected to R3 to configure the MAX3654 for AGC operation based on the average optical power level. In this case, the MAX3654 transimpedance is controlled by the average optical power level, as measured by the voltage across R21. The values of R1, R21 and R22 shown in Figure 1 will provide an output level of 15dBmV/ch ($\pm 1\text{dB}$) for optical input signals ranging from -6dBm to +2dBm, ($\text{OMI} = 3.5\%$, $N = 129$) using a typical triplexer photodiode. The total output signal level in this case is $15\text{dBmV/ch} + 10 \log(129 \text{ channels}) = 36\text{dBmV}$, which is the maximum operating level at which the specified linearity will be achieved. Operating at higher outputs may reduce MAX3654 performance.

Operating conditions (OMI, number of channels, responsivity, etc) change the VAGC setting required for a given output voltage. EV Kit AGC circuit gain can be increased by adding a voltage-divider, R22, to the op amp. To reduce gain the values of R1 and R21 should both be increased. Remember to keep the total output at 36dBmV or less to maintain the desired MAX3654 performance.

Photodiode Lead Configuration

Photodiode lead parasitic impedances can significantly effect performance of the MAX3654. It is especially important that the anode and cathode connections are electrically symmetric. Refer to Figure 1 in the MAX3654 data sheet. Note that the EV Kit layout is designed to minimize capacitance to ground in the input signal path.

MAX3654 Evaluation Kit

Adjustments and Control Descriptions

COMPONENT		NAME	FUNCTION
ELECTRICAL	OPTICAL		
JU5	JU1	MUTE	MUTE. TTL high enables output. Low mutes output.
NA	JU2	VAGC	Gain Control. Set JU2 to R4 for manual gain control. Set JU2 to R3 to allow feedforward AGC operation. The electrical circuit board is always set for manual gain control.
JU6	JU3	Hysteresis	Hysteresis. Leave open for (minimum) $\pm 0.13\text{dB}$ hysteresis between gain switch points. Connect $20\text{k}\Omega$ to ground for $\pm 0.3\text{dB}$ and short to GND for (maximum) $\pm 0.65\text{dB}$ hysteresis.

Evaluates: MAX3654

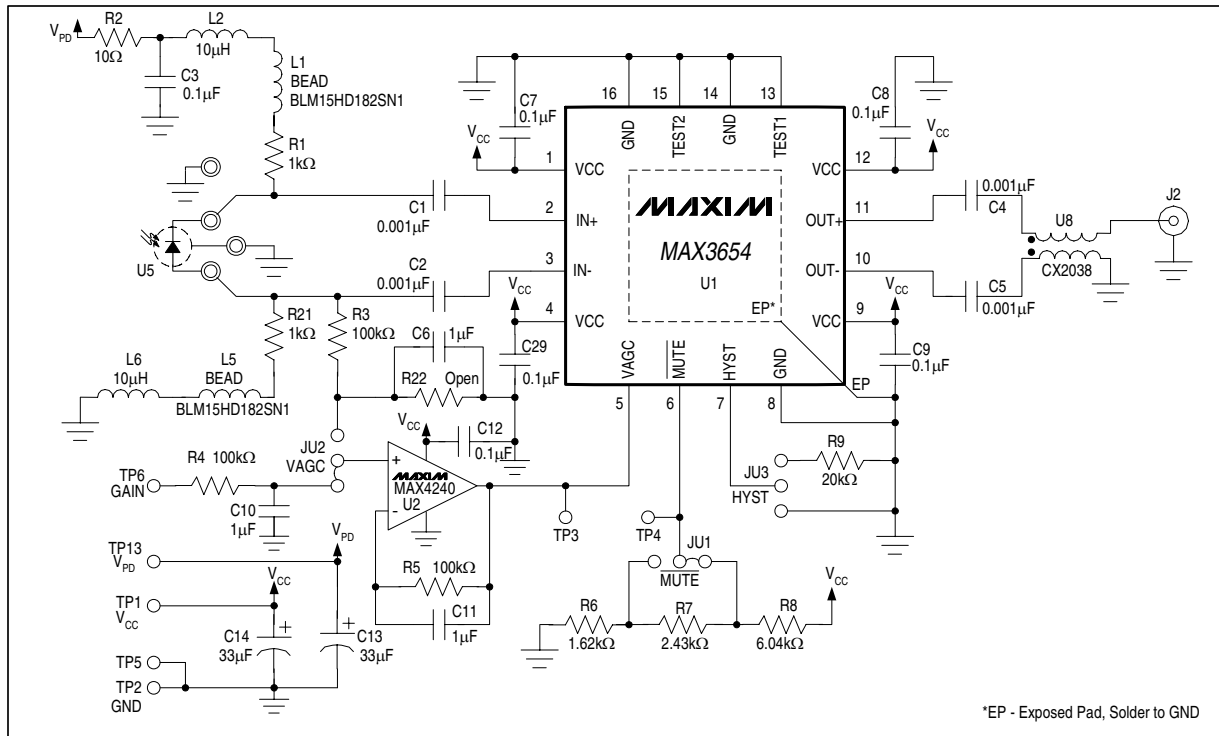

Figure 1. MAX3654 Optical EV Kit Schematic

MAX3654 Evaluation Kit

Evaluates: MAX3654

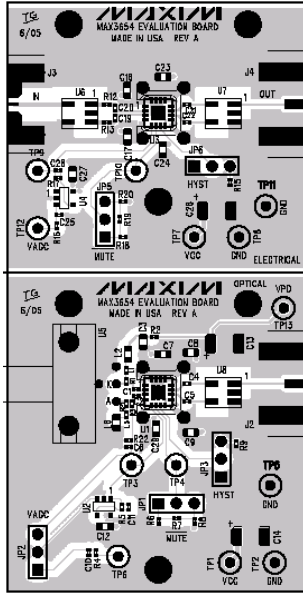

Figure 3. MAX3654 EV Kit PC Component Placement Guide—Component Side

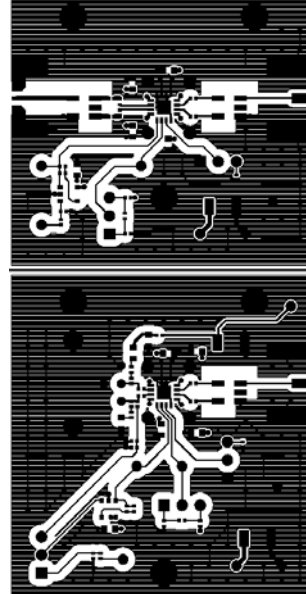

Figure 4. MAX3654 EV Kit PC Board Layout—Component Side

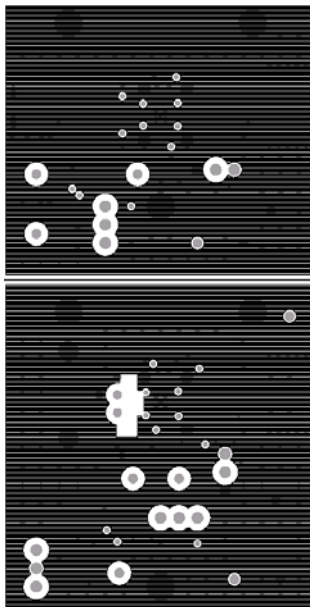

Figure 5. MAX3654 EV Kit PC Board Layout—Ground Plane

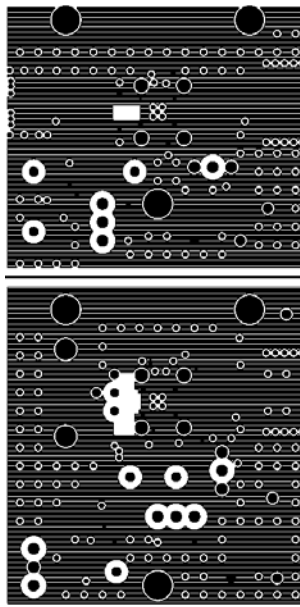

Figure 6. MAX3654 EV Kit PC Board Layout—Power Plane

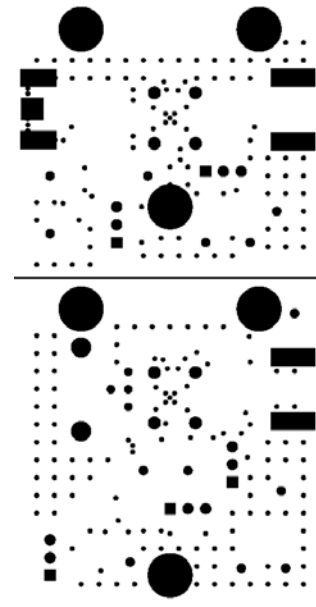

Figure 7. MAX3654 EV Kit PC Board Layout—Solder Side

Maxim cannot assume responsibility for use of any circuitry other than circuitry entirely embodied in a Maxim product. No circuit patent licenses are implied. Maxim reserves the right to change the circuitry and specifications without notice at any time.