



Chipsmall Limited consists of a professional team with an average of over 10 year of expertise in the distribution of electronic components. Based in Hongkong, we have already established firm and mutual-benefit business relationships with customers from,Europe,America and south Asia,supplying obsolete and hard-to-find components to meet their specific needs.

With the principle of “Quality Parts,Customers Priority,Honest Operation,and Considerate Service”,our business mainly focus on the distribution of electronic components. Line cards we deal with include Microchip,ALPS,ROHM,Xilinx,Pulse,ON,Everlight and Freescale. Main products comprise IC,Modules,Potentiometer,IC Socket,Relay,Connector.Our parts cover such applications as commercial,industrial, and automotives areas.

We are looking forward to setting up business relationship with you and hope to provide you with the best service and solution. Let us make a better world for our industry!



## Contact us

Tel: +86-755-8981 8866 Fax: +86-755-8427 6832

Email & Skype: info@chipsmall.com Web: www.chipsmall.com

Address: A1208, Overseas Decoration Building, #122 Zhenhua RD., Futian, Shenzhen, China





# 1Gbps to 10Gbps Preemphasis Driver with Receive Equalizer

## General Description

The MAX3984 is a single-channel, preemphasis driver with input equalization that operates from 1Gbps to 10.3Gbps. It provides compensation for copper links, such as 8.5Gbps Fibre Channel and 10.3Gbps Ethernet, allowing spans of up to 10m with 24 AWG cable. The driver provides four selectable preemphasis levels, and the selectable input equalizer compensates for up to 10in of FR-4 circuit board material at 10Gbps.

The MAX3984 also features SFP-compliant loss-of-signal (LOS) detection and TX\_DISABLE. Selectable output swing reduces EMI and power consumption. The MAX3984 is packaged in a lead-free, 3mm x 3mm, 16-pin thin QFN and operates from a 0°C to +85°C temperature range.

## Applications

8.5Gbps Fibre Channel	Active Cable Assemblies
10.3Gbps Ethernet	STM-64

Pin Configuration appears at end of data sheet.

## Features

- ◆ Drives Up to 10m of 24 AWG Cable
- ◆ Drives Up to 30in of FR-4
- ◆ Selectable 1000mVp-p or 1200mVp-p Differential Output Swing
- ◆ Selectable Output Preemphasis
- ◆ Selectable Input Equalization
- ◆ LOS Detection with Built-In Squelch
- ◆ Transmit Disable
- ◆ Hot Pluggable

## Ordering Information

PART	TEMP RANGE	PIN-PACKAGE	PKG CODE
MAX3984UTE+	0°C to +85°C	16 Thin QFN-EP*	T1633F-3

+Denotes a lead-free package.

\*EP = Exposed pad.

## Typical Operating Circuits

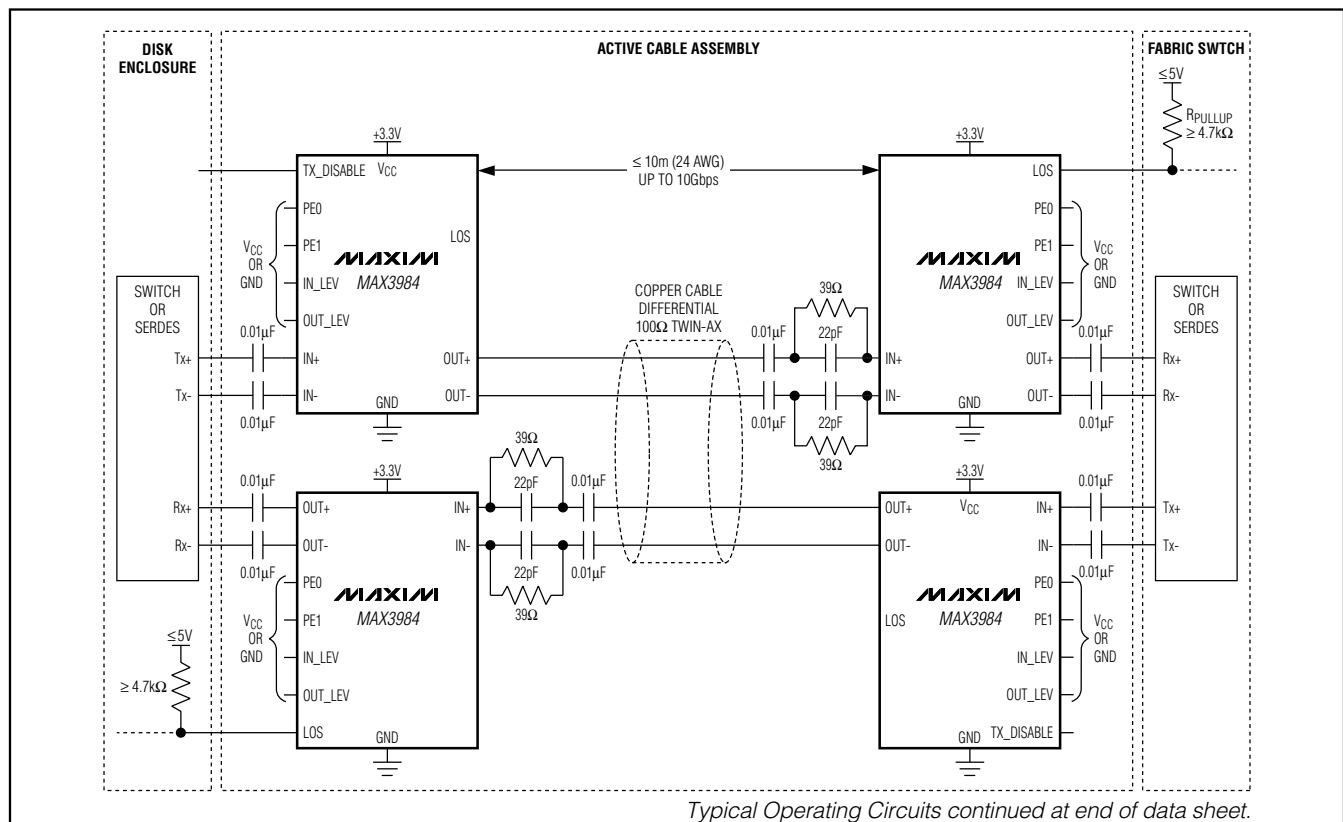

MAX3984

# 1Gbps to 10Gbps Preemphasis Driver with Receive Equalizer

## ABSOLUTE MAXIMUM RATINGS

Supply Voltage Range ( $V_{CC}$ ).....-0.5V to +4.1V  
 Continuous Output Current Range  
 (OUT+, OUT-) .....-25mA to +25mA  
 Input Voltage Range (IN+, IN-) .....-0.5V to ( $V_{CC} + 0.5V$ )

Logic Inputs Range (PE1, PE0,  
 TX\_DISABLE, IN\_LEV, OUT\_LEV) .....-0.5V to ( $V_{CC} + 0.5V$ )  
 LOS Open-Collector Supply Voltage Range  
 (with  $\geq 4.7k\Omega$  pullup) .....-0.5V to +5.5V  
 Storage Ambient Temperature Range ( $T_{STG}$ ) ...-55°C to +150°C

*Stresses beyond those listed under "Absolute Maximum Ratings" may cause permanent damage to the device. These are stress ratings only, and functional operation of the device at these or any other conditions beyond those indicated in the operational sections of the specifications is not implied. Exposure to absolute maximum rating conditions for extended periods may affect device reliability.*

## OPERATING CONDITIONS

PARAMETER	SYMBOL	CONDITIONS	MIN	TYP	MAX	UNITS
Supply Voltage	$V_{CC}$		3.0	3.3	3.6	V
Supply Noise Tolerance		$1MHz \leq f < 2GHz$		40		mV <sub>P-P</sub>
Operating Ambient Temperature	$T_A$		0	25	85	°C
Bit Rate		NRZ data	1.0	8.5	10.3	Gbps
Consecutive Identical Digits (CID)		CID (bits)			100	Bits
Input Swing (Measured differentially at data source, point A of Figure 2 and 3. Pins LOS and TX_DISABLE are floating.)		IN_LEV = high, Figure 2; 4.25Gbps < data rate ≤ 10.3Gbps	360		1200	mV <sub>P-P</sub>
		IN_LEV = high, Figure 2; 1.25Gbps < data rate ≤ 4.25Gbps	360		1600	
		IN_LEV = high, Figure 2; 1.0Gbps ≤ data rate ≤ 1.25Gbps	360		2400	
		IN_LEV = low, Figure 3; 1.0Gbps < data rate ≤ 10.3Gbps	100		360	
Time to Reach 50% Mark/Space Ratio					1	μs

# 1Gbps to 10Gbps Preemphasis Driver with Receive Equalizer

**MAX3984**

## ELECTRICAL CHARACTERISTICS

(V<sub>CC</sub> = +3.0V to +3.6V, T<sub>A</sub> = 0°C to +85°C. Typical values are at T<sub>A</sub> = +25°C, V<sub>CC</sub> = +3.3V, unless otherwise noted.)

PARAMETER	SYMBOL	CONDITIONS		MIN	TYP	MAX	UNITS
Supply Current	I <sub>CC</sub>	OUT_LEV = low, TX_DISABLE = low			100	124	mA
		OUT_LEV = high, TX_DISABLE = low			120	148	
Inrush Current		Beyond steady state supply current (Note 1)				10	mA
Power-On Delay		(Note 1)		1		30	ms
<b>EQUALIZER AND DRIVE SPECIFICATIONS</b>							
Input Return Loss	S11	100MHz to 5GHz			10		dB
Input Resistance		Measured differentially (Note 2)		85	100	115	Ω
Differential Output Swing (Notes 3, 4)		Measured differentially at point B in Figure 2; TX_DISABLE = low, OUT_LEV = high, PE1 = PE0 = high		1000		1300	mV <sub>P-P</sub>
		Measured differentially at point B in Figure 2; TX_DISABLE = low, OUT_LEV = low, PE1 = PE0 = high		800		1100	
		TX_DISABLE = high, PE1 = PE0 = high				10	
Common-Mode Output (AC) (Note 4)		Measured at point B in Figure 2; TX_DISABLE = low, OUT_LEV = high (Note 5)				25	mV <sub>RMS</sub>
Output Resistance	R <sub>OUT</sub>	OUT+ or OUT-, single-ended		42	50	58	Ω
Output Return Loss	S22	100MHz to 5GHz			12		dB
Output Transition Time 20% to 80%	t <sub>r</sub> , t <sub>f</sub>	20% to 80% (Note 6)			32	40	ps
Random Jitter (Note 4)		Measured at point D in Figure 3 (Note 7)				0.8	ps <sub>RMS</sub>
Output Preemphasis		Figure 1 (Note 3)		PE1	PE0		dB
				0	0	3.5	
				0	1	6.5	
				1	0	9.5	
				1	1	13	
Residual Output Deterministic Jitter at 1.0Gbps (Notes 4, 8, and 9)		Source to IN	OUT to load	PE1	PE0	0.02	UI <sub>P-P</sub>
		6-mil, 10in of FR-4	3m, 24 AWG	0	0		
			5m, 24 AWG	0	1		
			7m, 24 AWG	1	0		
			10m, 24 AWG	1	1		

# 1Gbps to 10Gbps Preemphasis Driver with Receive Equalizer

## ELECTRICAL CHARACTERISTICS (continued)

(V<sub>CC</sub> = +3.0V to +3.6V, T<sub>A</sub> = 0°C to +85°C. Typical values are at T<sub>A</sub> = +25°C, V<sub>CC</sub> = +3.3V, unless otherwise noted.)

PARAMETER	SYMBOL	CONDITIONS				MIN	TYP	MAX	UNITS
Residual Output Deterministic Jitter at 5.0Gbps (Notes 4, 8, and 9)		Source to IN	OUT to load	PE1	PE0	0.09	0.12	UI <sub>P-P</sub>	
		6-mil, 10in of FR-4	3m, 24 AWG	0	1				
			5m, 24 AWG	1	0				
			7m, 24 AWG	1	0				
			10m, 24 AWG	1	1				
Residual Output Deterministic Jitter at 8.5Gbps (Notes 4, 8, and 9)		Source to IN	OUT to load	PE1	PE0	0.15	0.20	UI <sub>P-P</sub>	
		6-mil, 10in of FR-4	3m, 24 AWG	0	1				
			5m, 24 AWG	1	0				
			7m, 24 AWG	1	0				
			10m, 24 AWG	1	1				
Residual Output Deterministic Jitter at 10Gbps (Notes 4, 8, and 9)		Source to IN	OUT to load	PE1	PE0	0.18	0.25	UI <sub>P-P</sub>	
		6-mil, 10in of FR-4	3m, 24 AWG	0	1				
			5m, 24 AWG	1	0				
			7m, 24 AWG	1	1				
			10m, 24 AWG	1	1				
Residual Output Deterministic Jitter at 10.0Gbps (Notes 4, 8, and 10)		10in of FR-4 at OUT±; no cable; see Figure 3		PE1	PE0	0.10		UI <sub>P-P</sub>	
				0	0				
Propagation Delay						230		ps	
<b>STATUS OUTPUT: LOS</b>									
LOS Deassert		IN_LEV = high (Note 11)				300		mV <sub>P-P</sub>	
		IN_LEV = low (Note 11)				100			
LOS Assert		IN_LEV = high (Note 11)				80			
LOS Hysteresis (Note 4)		IN_LEV = high (Note 11)				20		mV <sub>P-P</sub>	
		IN_LEV = low (Note 11)				10			

# 1Gbps to 10Gbps Preemphasis Driver with Receive Equalizer

MAX3984

## ELECTRICAL CHARACTERISTICS (continued)

( $V_{CC} = +3.0V$  to  $+3.6V$ ,  $T_A = 0^\circ C$  to  $+85^\circ C$ . Typical values are at  $T_A = +25^\circ C$ ,  $V_{CC} = +3.3V$ , unless otherwise noted.)

PARAMETER	SYMBOL	CONDITIONS	MIN	TYP	MAX	UNITS
LOS Open-Collector Current Sink		LOS asserted	0		25	$\mu A$
		LOS asserted; $V_{OL} \leq 0.4V$	1.0			mA
		(Note 12)	0		25	$\mu A$
LOS Response Time (Note 4)		Time from $V_{IN}$ dropping below deassert level or rising above assert level to 50% point of LOS output transition			10	$\mu s$
LOS Transition Time		Rise time or fall time (10% to 90%); pullup supply = 5.5V; external pullup $R \geq 4.7k\Omega$		200		ns
<b>CONTROL INPUTS: TX_DISABLE, PE0, PE1, OUT_LEV, IN_LEV</b>						
Logic-High Voltage	$V_{IH}$		2.0			V
Logic-Low Voltage	$V_{IL}$				0.8	V
Logic-High Current	$I_{IH}$	Current required to maintain logic-high state at $V_{IH} > +2.0V$			-150	$\mu A$
Logic-Low Current	$I_{IL}$	Current required to maintain logic-low state at $V_{IL} < +0.8V$			350	$\mu A$

**Note 1:** Supply voltage to reach 90% of final value in less than 100 $\mu s$ , but not less than 10 $\mu s$ . Power-on delay interval measured from the 50% level of the final voltage at the filter's device side to 50% level of final current. The supply is to remain at or above 3V for at least 100ms. Only one full-scale transition is permitted during this interval. Aberrations on the transition are limited to less than 100mV.

**Note 2:** IN+ and IN- are single-ended, 50 $\Omega$  terminations to  $(V_{CC} - 1.5V) \pm 0.2V$ .

**Note 3:** Load is 50 $\Omega \pm 1\%$  at each side and the pattern is 0000011111 or equivalent pattern at 2.5Gbps.

**Note 4:** Guaranteed by design and characterization.

**Note 5:** PE1 = PE0 = logic-high (maximum preemphasis), load is 50 $\Omega \pm 1\%$  at each side. The pattern is 11001100 (50% edge density) at 10Gbps. AC common-mode output is computed as:

$$V_{ACCM\_RMS} = RMS[(V_P + V_N) / 2] - V_{DCCM}$$

where:

$V_P$  = time-domain voltage measured at OUT+ with at least 10GHz bandwidth.

$V_N$  = time-domain voltage measured at OUT- with at least 10GHz bandwidth.

AC common-mode voltage ( $V_{ACCM\_RMS}$ ) expressed as an RMS value.

DC common-mode voltage ( $V_{DCCM}$ ) = average DC voltage of  $(V_P + V_N) / 2$ .

**Note 6:** Using 0000011111 or equivalent pattern at 2.5Gbps. PE0 = PE1 = logic-low for minimum preemphasis. Measured within 2in of the output pins with Rogers 4350 dielectric, or equivalent, and  $\geq 10$ -mil line width. For transition time, the 0% reference is the steady state level after four zeros, just before the transition, and the 100% reference level is the steady state level after four consecutive logic ones.

**Note 7:** Pattern is 0000011111 or equivalent pattern at 10Gbps and 100mV<sub>P-P</sub> differential swing. IN\_LEV = logic-low and PE0 = PE1 = logic-low for minimum preemphasis. Signal transition time is controlled by the 4th-order BT filter (7.5GHz bandwidth) or equivalent. See Figure 3 for setup.

**Note 8:** Test pattern (464 bits): 100 zeros, 1010, PRBS7, 100 ones, 0101, PRBS7.

**Note 9:** Input range selection is IN\_LEV = logic-high for FR-4 input equalization. Cables are unequalized, Amphenol Spectra-Strip (160-2499-997) 24 AWG or equivalent. Residual deterministic jitter is the difference between the source jitter at point A and the load jitter point D in Figure 2. The deterministic jitter (DJ) at the output of the transmission line must be from media induced loss and not from clock source modulation. DJ is measured at point D of Figure 2.

**Note 10:** Input range selection is IN\_LEV = logic-low. Residual deterministic jitter is the difference between the source jitter at point A and the load jitter point D in Figure 3. The deterministic jitter (DJ) at the output of the transmission line must be from media induced loss and not from clock source modulation. DJ is measured at point D of Figure 3.

**Note 11:** Measured with 101010... pattern at 10Gbps with less than 1in of FR-4 at the input.

**Note 12:** True open-collector outputs.  $V_{CC} = 0$  and the external 4.7k $\Omega$  pullup resistor is connected to +5.5V.

# 1Gbps to 10Gbps Preemphasis Driver with Receive Equalizer

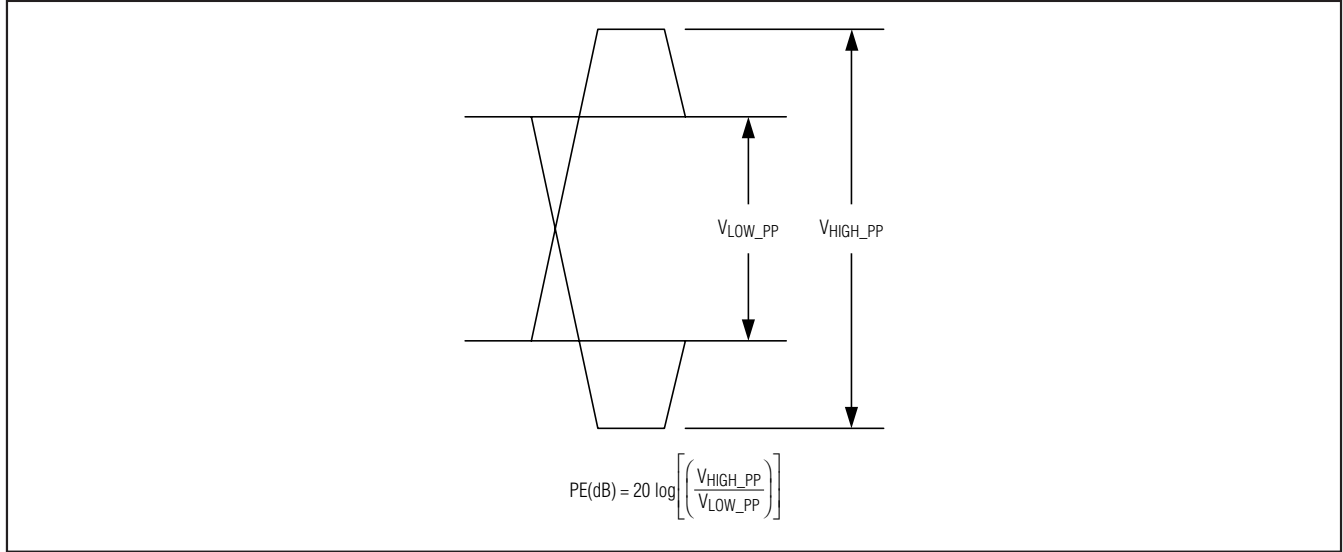

Figure 1. TX Preemphasis in dB

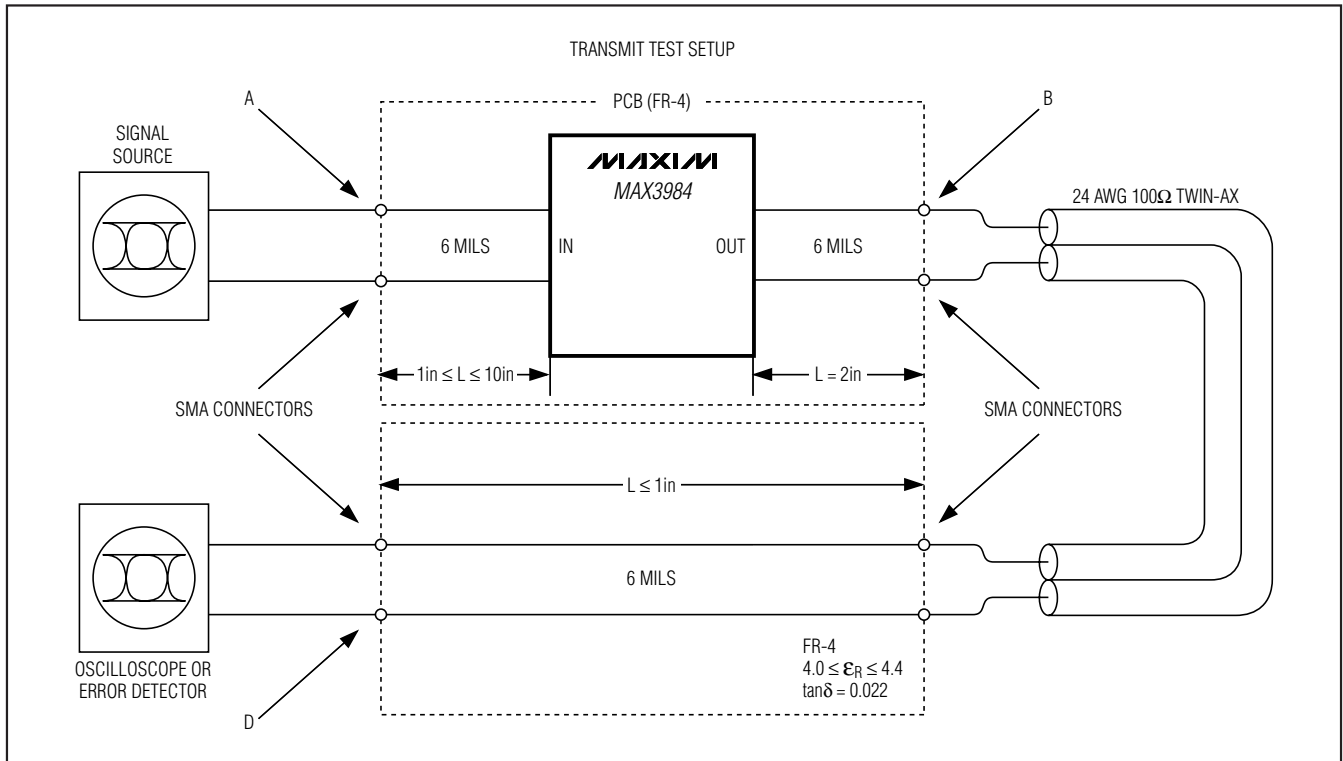

Figure 2. Transmit Test Setup (The points labeled A, B, and D are referenced for AC parameter test conditions. Deterministic jitter and eye diagrams measured at point D.)

# 1Gbps to 10Gbps Preemphasis Driver with Receive Equalizer

MAX3984

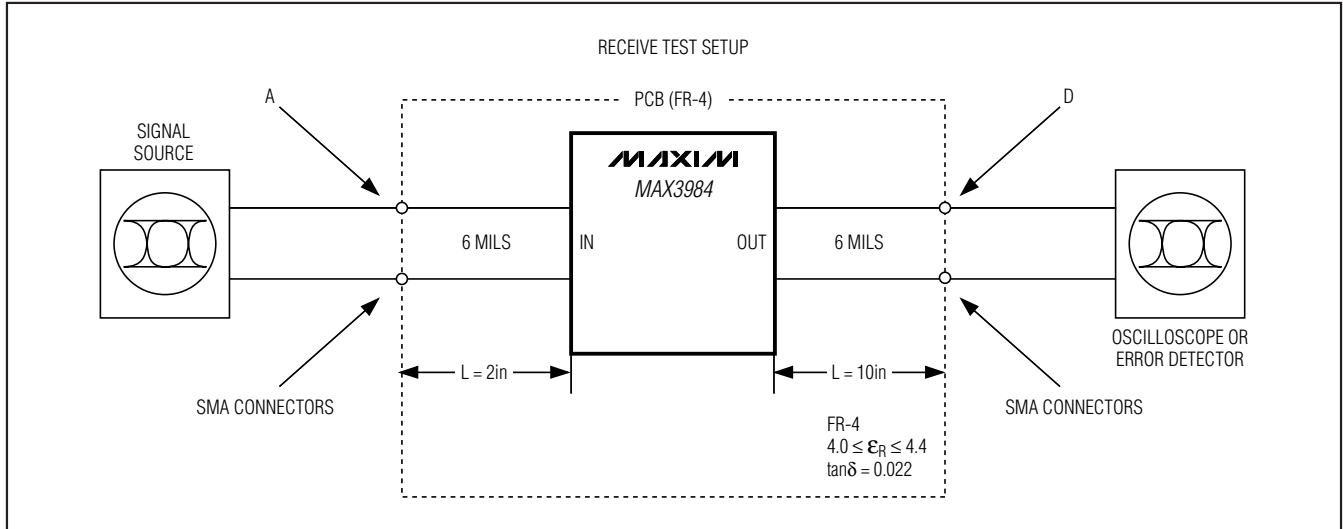
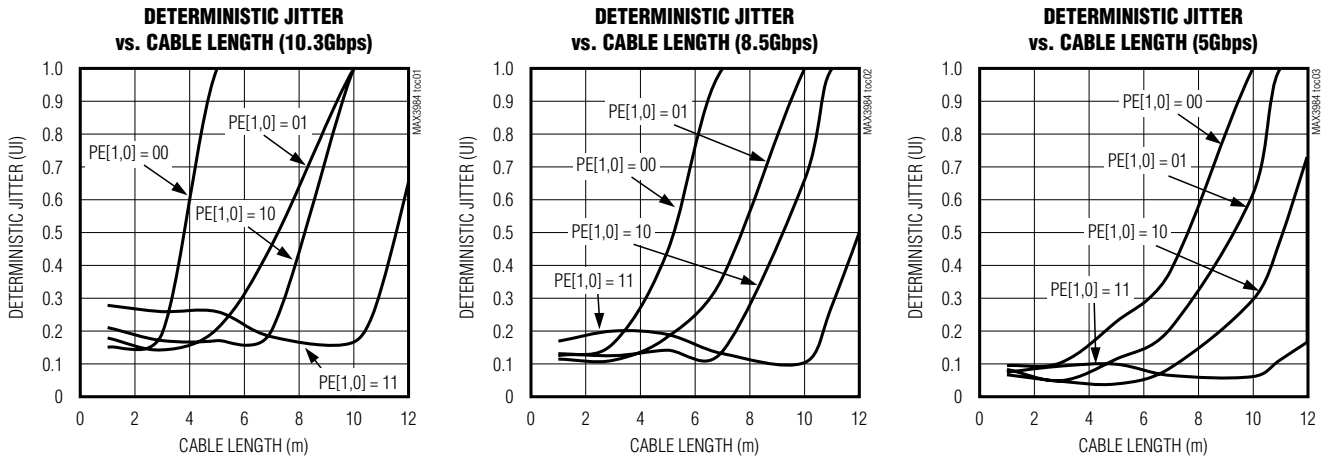

Figure 3. Receive-Side Test Setup (The points labeled A and D are referenced for AC parameter tests.)

## Typical Operating Characteristics

( $V_{CC} = +3.3V$ ,  $T_A = +25^\circ C$ , PRBS7 + 100 CID pattern is PRBS  $2^7$ , 100 zeros, 1010, PRBS  $2^7$ , 100 ones, 0101, OUT\_LEV = high, 10in of FR-4 at the input, IN\_LEV = high, 360mV<sub>p-p</sub> at input of FR-4, unless otherwise noted.)



# 1Gbps to 10Gbps Preemphasis Driver with Receive Equalizer

## Typical Operating Characteristics (continued)

( $V_{CC} = +3.3V$ ,  $T_A = +25^\circ C$ , PRBS7 + 100 CID pattern is PRBS 2<sup>7</sup>, 100 zeros, 1010, PRBS 2<sup>7</sup>, 100 ones, 0101, OUT\_LEV = high, 10in of FR-4 at the input, IN\_LEV = high, 360mV<sub>p-p</sub> at input of FR-4, unless otherwise noted.)

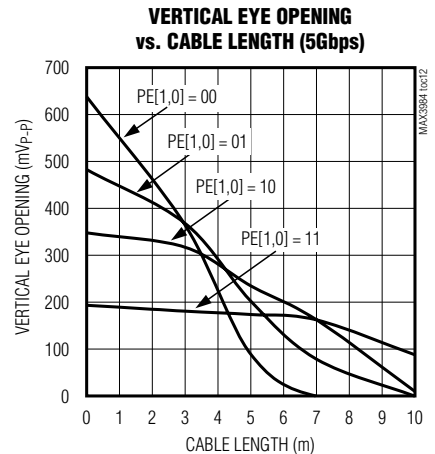
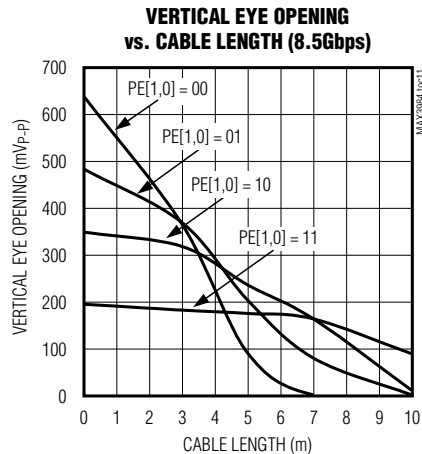
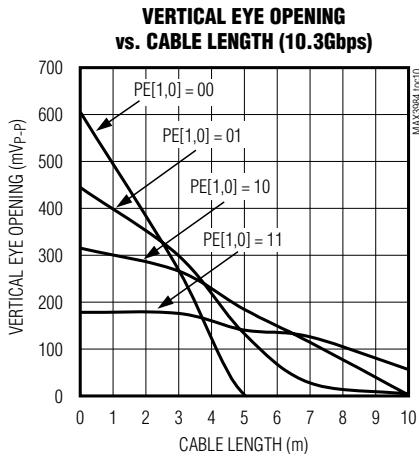
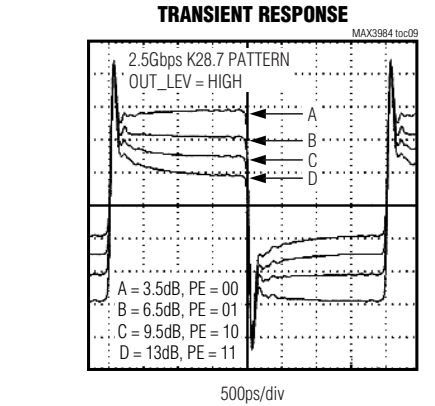
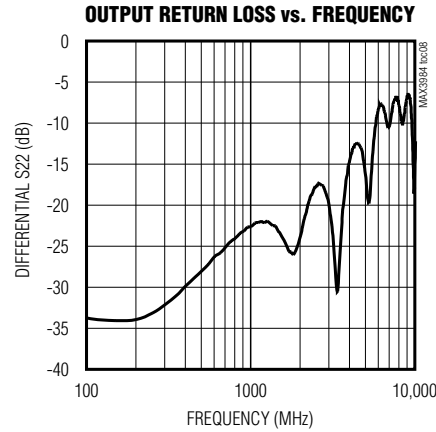
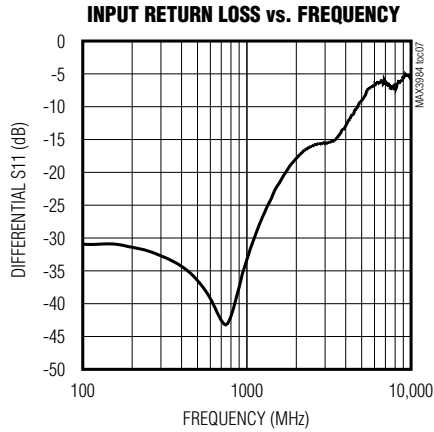
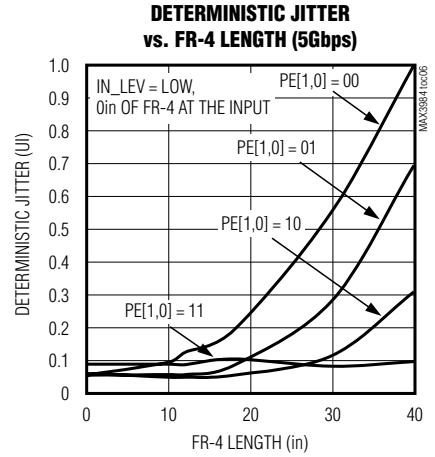
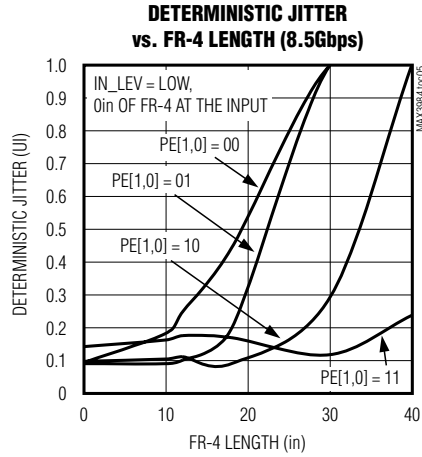
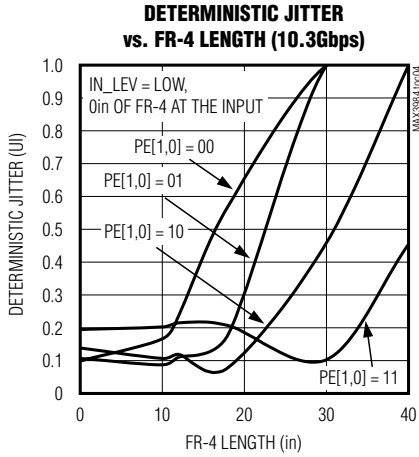

# 1Gbps to 10Gbps Preemphasis Driver with Receive Equalizer

MAX3984

## Typical Operating Characteristics (continued)

( $V_{CC} = +3.3V$ ,  $T_A = +25^\circ C$ , PRBS7 + 100 CID pattern is PRBS  $2^7$ , 100 zeros, 1010, PRBS  $2^7$ , 100 ones, 0101,  $OUT\_LEV = high$ , 10in of FR-4 at the input,  $IN\_LEV = high$ , 360mV<sub>p-p</sub> at input of FR-4, unless otherwise noted.)

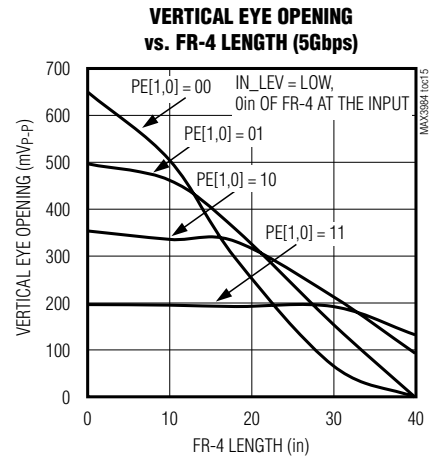
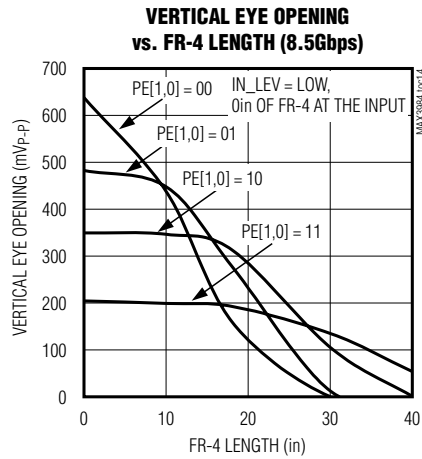
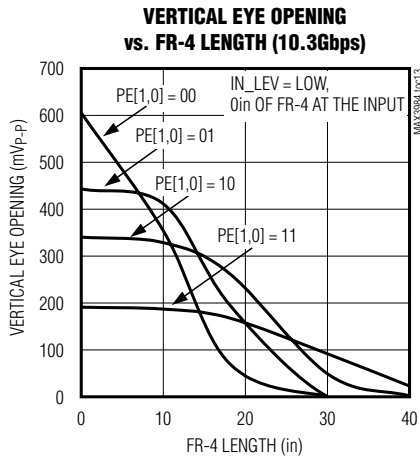

**10m 24 AWG CABLE ASSEMBLY OUTPUT WITHOUT MAX3984 AT 10.3Gbps**

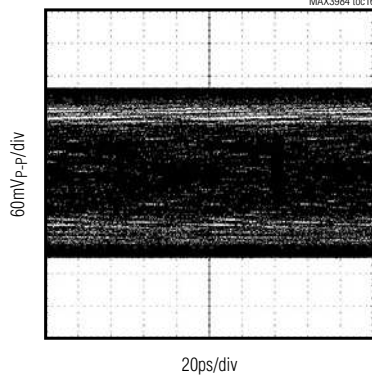

**10m 24 AWG CABLE ASSEMBLY OUTPUT WITH MAX3984 AT 10.3Gbps (PREEMPHASIS, PE[1,0] = 11, OUT\_LEV = HIGH)**

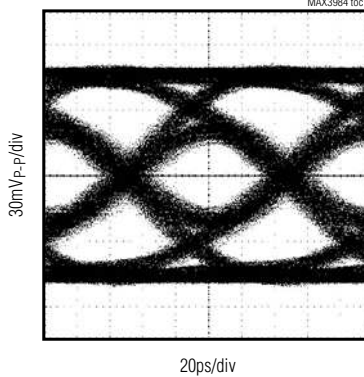

**10m 24 AWG CABLE ASSEMBLY OUTPUT WITHOUT MAX3984 AT 8.5Gbps**

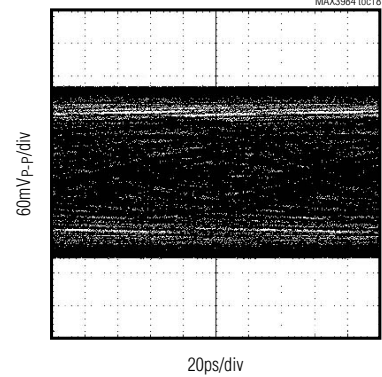

**10m 24 AWG CABLE ASSEMBLY OUTPUT WITH MAX3984 AT 8.5Gbps (PREEMPHASIS, PE[1,0] = 11, OUT\_LEV = HIGH)**

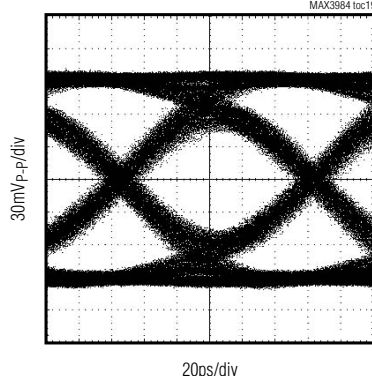

**10m 24 AWG CABLE ASSEMBLY OUTPUT WITHOUT MAX3984 AT 5Gbps**

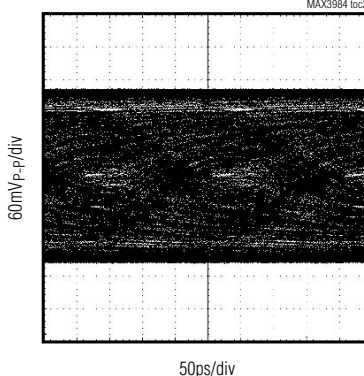

**10m 24 AWG CABLE ASSEMBLY OUTPUT WITH MAX3984 AT 5Gbps (PREEMPHASIS, PE[1,0] = 11, OUT\_LEV = HIGH)**

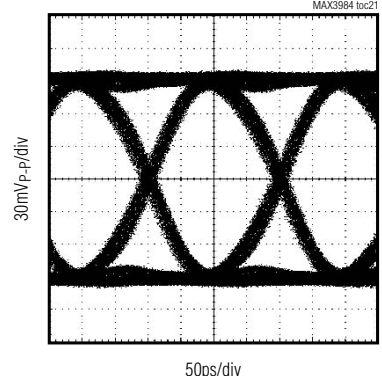

# 1Gbps to 10Gbps Preemphasis Driver with Receive Equalizer

## Pin Description

PIN	NAME	FUNCTION
1	V <sub>CC1</sub>	Power-Supply Connection for Inputs. Connect to +3.3V.
2	IN+	Positive Data Input, CML. This input is internally terminated with 50Ω.
3	IN-	Negative Data Input, CML. This input is internally terminated with 50Ω.
4, 8, 9, 16	GND	Circuit Ground
5	OUT_LEV	Output-Swing Control Input, LVTTTL with 20kΩ Internal Pullup. Set to TTL high or open for maximum output swing, or set to TTL low for reduced swing.
6	PE1	Output Preemphasis Control Input, LVTTTL with 10kΩ Internal Pullup. This pin is the most significant bit of the 2-bit preemphasis control. Set high or open to assert this pin.
7	PE0	Output Preemphasis Control Input, LVTTTL with 10kΩ Internal Pullup. This pin is the least significant bit of the 2-bit preemphasis control. Set high or open to assert this pin.
10	OUT-	Negative Data Output, CML. This output is terminated with 50Ω to V <sub>CC2</sub> .
11	OUT+	Positive Data Output, CML. This output is terminated with 50Ω to V <sub>CC2</sub> .
12	V <sub>CC2</sub>	Power-Supply Connection for Output. Connect to +3.3V.
13	TX_DISABLE	Transmitter Disable Input, LVTTTL with 10kΩ Internal Pullup. When high or open, differential output is less than 10mV <sub>P-P</sub> . Set low for normal operation.
14	LOS	Loss-of-Signal Detect, Open-Collector TTL Output. Requires an external pullup $\geq 4.7k\Omega$ (+5.5V maximum). This output sinks current when the input signal is above the LOS deassert level. To disable squelch pull LOS to ground.
15	IN_LEV	Receive Equalization Control Input, LVTTTL 40kΩ Internal Pullup. Set to TTL high or open for higher LOS assert/deassert levels and 10in FR-4 compensation. Set to TTL low for lower LOS assert/deassert levels and to bypass the FR-4 equalization.
—	EP	Exposed Pad. For optimal thermal conductivity, this pad must be soldered to the circuit board ground.

## Detailed Description

The MAX3984 is composed of a receiver, a driver, and an LOS detector with selectable threshold. Equalization is provided in the receiver. Selectable preemphasis and selectable output amplitude are included in the transmitter. The MAX3984 also includes transmit disable control for the output.

### Receiver

Data is fed into the MAX3984 through a CML input stage and a selectable equalization stage. The fixed equalizer in the receiver corrects for up to 10in of PCB loss on FR-4 material at 10Gbps. The fixed equalizer can be bypassed by setting the IN\_LEV pin to a logic-low.

### Driver

The driver includes four-state preemphasis to compensate for up to 10m of 24 AWG, 100Ω balanced cable, or 30in of FR-4. The OUT\_LEV pin selects the output amplitude. When OUT\_LEV is low, the peak-to-peak amplitude is 1000mV<sub>P-P</sub>. When OUT\_LEV is high, the peak-to-peak amplitude is 1200mV<sub>P-P</sub>.

### Loss of Signal (LOS)

Input LOS detection is provided. This is an open-collector output and requires an external pullup resistor ( $\geq 4.7k\Omega$ ). The pullup resistors should be connected from LOS to a supply in the +3.0V to +5.5V range. The LOS output is not valid until power-up is complete.

# 1Gbps to 10Gbps Preemphasis Driver with Receive Equalizer

MAX3984

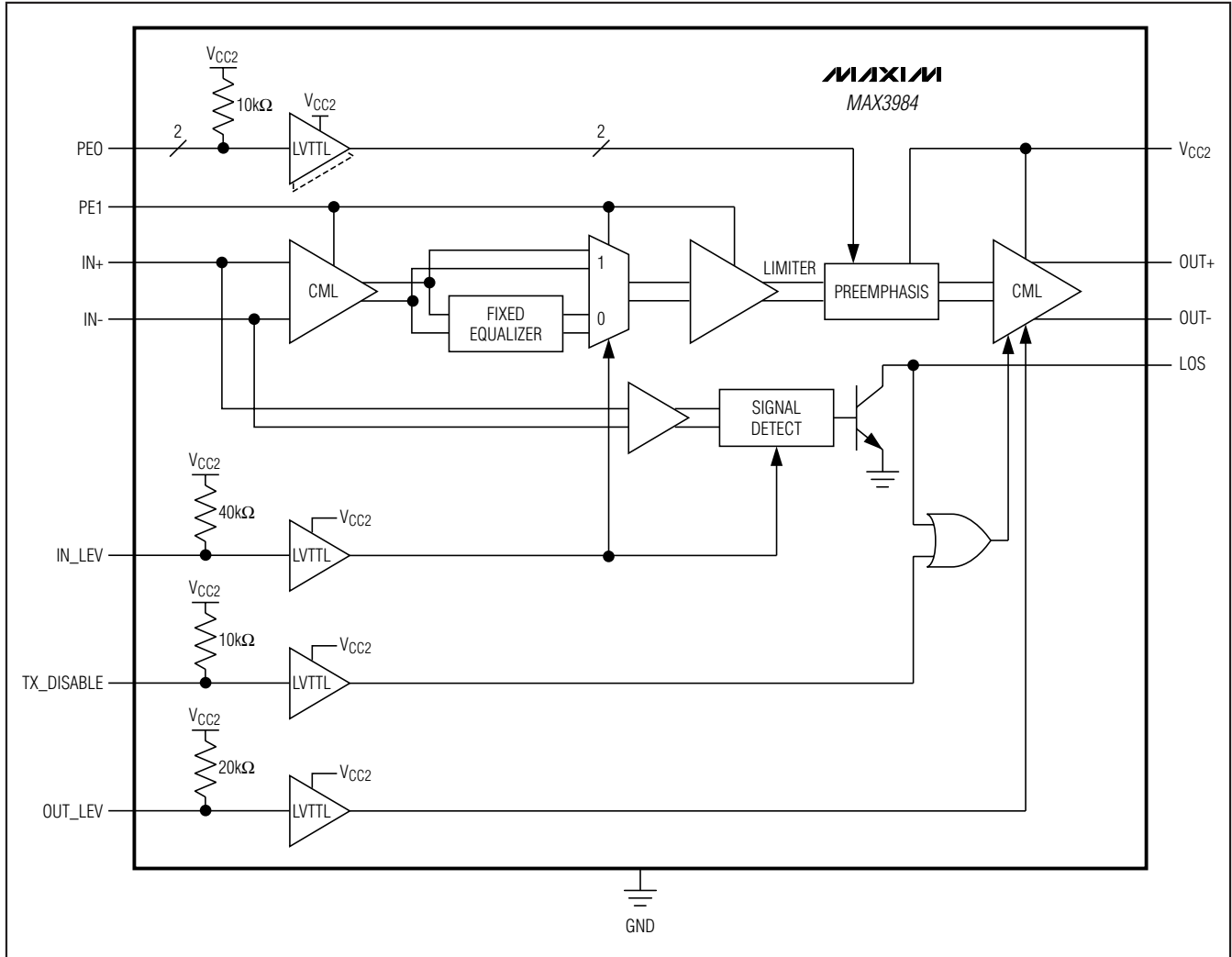

Figure 4. Functional Diagram

The IN\_LEV pin sets the LOS assert and deassert levels. When IN\_LEV is LVTTTL high or open, the LOS assert threshold is 300mV<sub>p-p</sub>. When IN\_LEV is LVTTTL low, the LOS assert threshold is 100mV<sub>p-p</sub>.

TX\_DISABLE provides manual control for turning the output off. The MAX3984 has a squelch function that disables the output when there is an LOS condition. To disable the squelch function, connect LOS to ground (see the *Squelch* section).

## Applications Information

### Squelch

The MAX3984 can automatically detect an incoming signal and enable or disable the data outputs. To enable squelch, the LOS pin must be connected to a TTL high or V<sub>CC</sub> with a pullup resistor ( $\geq 4.7\text{k}\Omega$ ). Internally, TX\_DISABLE and LOS are connected through an OR-gate to control the CML outputs. The outputs are disabled if LOS asserts. To turn off the squelch function, LOS must be pulled to TTL low. The output can also be disabled when TX\_DISABLE is forced high.

# 1Gbps to 10Gbps Preemphasis Driver with Receive Equalizer

## Typical Characteristics at -40°C

The MAX3984 is guaranteed to work from 0°C to +85°C. Table 1 indicates typical performance outside the guaranteed limits.

**Table 1. Typical Characteristics at -40°C**

PARAMETER	SYMBOL	CONDITIONS				MIN	TYP	MAX	UNITS
Different Output Swing (Note 1)		Measured differentially at point B in Figure 2; TX_DISABLE = low, OUT_LEV = high, PE1 = PE0 = high					1100		mV <sub>P-P</sub>
		Measured differentially at point B in Figure 2; TX_DISABLE = low, OUT_LEV = low, PE1 = PE0 = high					920		
		TX_DISABLE = high, PE1 = PE0 = high					3.5		
Common-Mode Output (AC)		Measured at point B in Figure 2; TX_DISABLE = low, OUT_LEV = high (Note 2)					5		mV <sub>RMS</sub>
Random Jitter		Measured at point D in Figure 3 (Note 3)					0.5		pS <sub>RMS</sub>
Residual Output Deterministic Jitter at 1.0Gbps (Notes 4, 5)		Source to IN	OUT to load	PE1	PE0		0.02		UI <sub>P-P</sub>
		6-mil, 10in of FR-4	3m, 24 AWG	0	0				
			5m, 24 AWG	0	1				
			7m, 24 AWG	1	0				
			10m, 24 AWG	1	1				
Residual Output Deterministic Jitter at 5.0Gbps (Notes 4, 5)		Source to IN	OUT to load	PE1	PE0		0.12		UI <sub>P-P</sub>
		6-mil, 10in of FR-4	3m, 24 AWG	0	1				
			5m, 24 AWG	1	0				
			7m, 24 AWG	1	0				
			10m, 24 AWG	1	1				
Residual Output Deterministic Jitter at 8.5Gbps (Notes 4, 5)		Source to IN	OUT to load	PE1	PE0		0.2		UI <sub>P-P</sub>
		6-mil, 10in of FR-4	3m, 24 AWG	0	1				
			5m, 24 AWG	1	0				
			7m, 24 AWG	1	0				
			10m, 24 AWG	1	1				

# 1Gbps to 10Gbps Preemphasis Driver with Receive Equalizer

**MAX3984**

**Table 1. Typical Characteristics at -40°C (continued)**

PARAMETER	SYMBOL	CONDITIONS				MIN	TYP	MAX	UNITS
Residual Output Deterministic Jitter at 10Gbps (Notes 4, 5)		Source to IN	OUT to load	PE1	PE0		0.25		UI <sub>p-p</sub>
		6-mil, 10in of FR-4	3m, 24 AWG	0	1				
			5m, 24 AWG	1	0				
			7m, 24 AWG	1	1				
			10m, 24 AWG	1	1				

**Note 1:** Load is  $50\Omega \pm 1\%$  at each side and the pattern is 0000011111 or equivalent pattern at 2.5Gbps.

**Note 2:** PE1 = PE0 = logic-high (maximum preemphasis), load is  $50\Omega \pm 1\%$  at each side. The pattern is 11001100 (50% edge density) at 10Gbps. AC common-mode output is computed as:

$$V_{ACCM\_RMS} = \text{RMS}[(V_P + V_N) / 2] - V_{DCCM}$$

where:

$V_P$  = time-domain voltage measured at OUT+ with at least 10GHz bandwidth.

$V_N$  = time-domain voltage measured at OUT- with at least 10GHz bandwidth.

AC common-mode voltage ( $V_{ACCM\_RMS}$ ) expressed as an RMS value.

DC common-mode voltage ( $V_{DCCM}$ ) = average DC voltage of  $(V_P + V_N) / 2$ .

**Note 3:** Pattern is 0000011111 or equivalent pattern at 10Gbps and 100mV<sub>p-p</sub> differential swing. IN\_LEV = logic-low and PE0 = PE1 = logic-low for minimum preemphasis. Signal transition time is controlled by the 4th-order BT filter (7.5GHz bandwidth) or equivalent. See Figure 3 for setup.

**Note 4:** Test pattern (464 bits): 100 zeros, 1010, PRBS7, 100 ones, 0101, PRBS7.

**Note 5:** Input range selection is IN\_LEV = logic-high for FR-4 input equalization. Cables are unequalized, Amphenol Spectra-Strip (160-2499-997) 24 AWG or equivalent. Residual deterministic jitter is the difference between the source jitter at point A and the load jitter point D in Figure 2. The deterministic jitter (DJ) at the output of the transmission line must be from media induced loss and not from clock source modulation. DJ is measured at point D of Figure 2.

# 1Gbps to 10Gbps Preemphasis Driver with Receive Equalizer

## Layout Considerations

Circuit board layout and design can significantly affect the performance of the MAX3984. Use good high-frequency design techniques, including minimizing ground inductance and using controlled-impedance transmission lines on the data signals. Power-supply decoupling should also be placed as close as possible to the VCC pins. Always connect all VCC pins to a power plane. Take care to isolate the input from the output signals to reduce feed through.

## Exposed-Pad Package

The exposed-pad, 16-pin thin QFN package incorporates features that provide a very low thermal resistance path for heat removal from the IC. The exposed pad on the MAX3984 must be soldered to the circuit board for proper thermal performance. Refer to Maxim Application Note HFAN-08.1: *Thermal Considerations of QFN and Other Exposed-Paddle Packages* for additional information.

## Interface Schematics

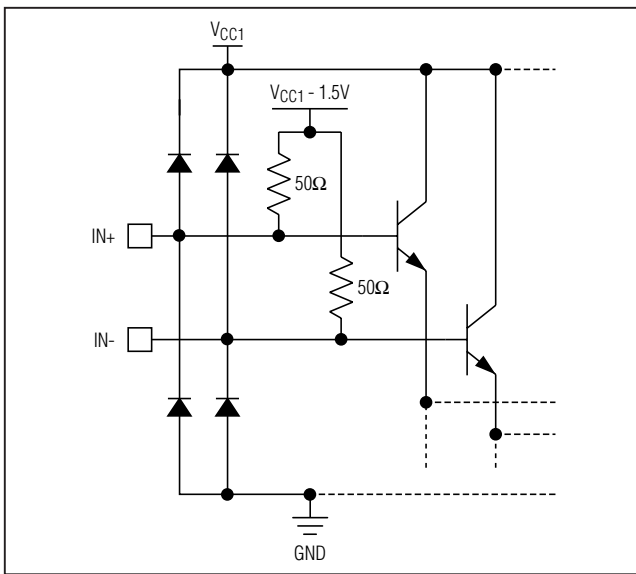

Figure 5. IN+/IN- Equivalent Input Structure

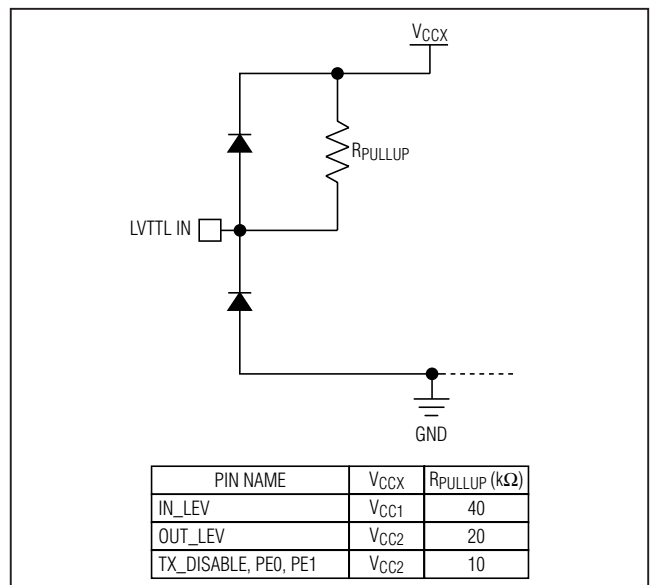

Figure 7. LVTTTL Equivalent Input Structure

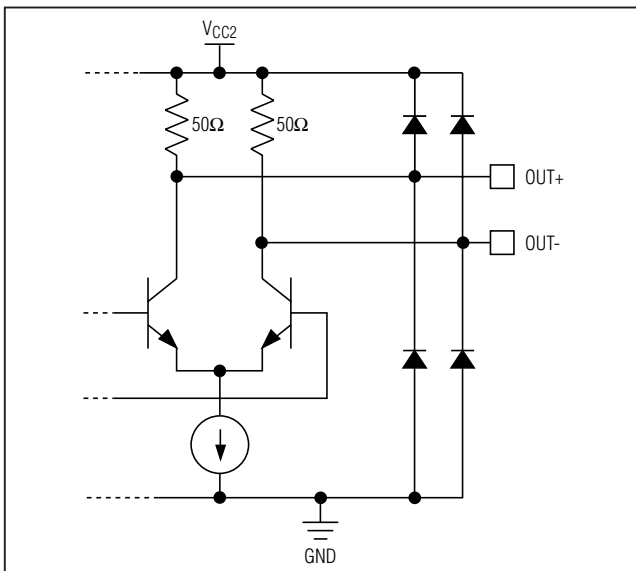

Figure 6. OUT+/OUT- Equivalent Output Structure

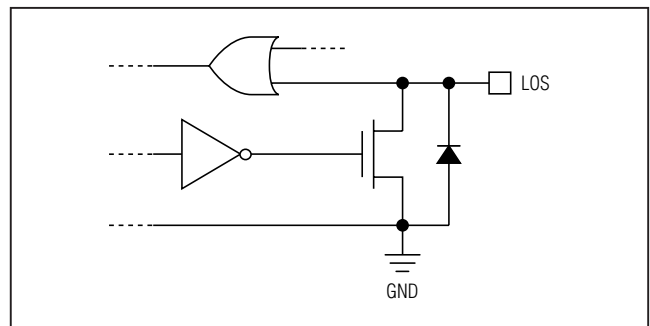
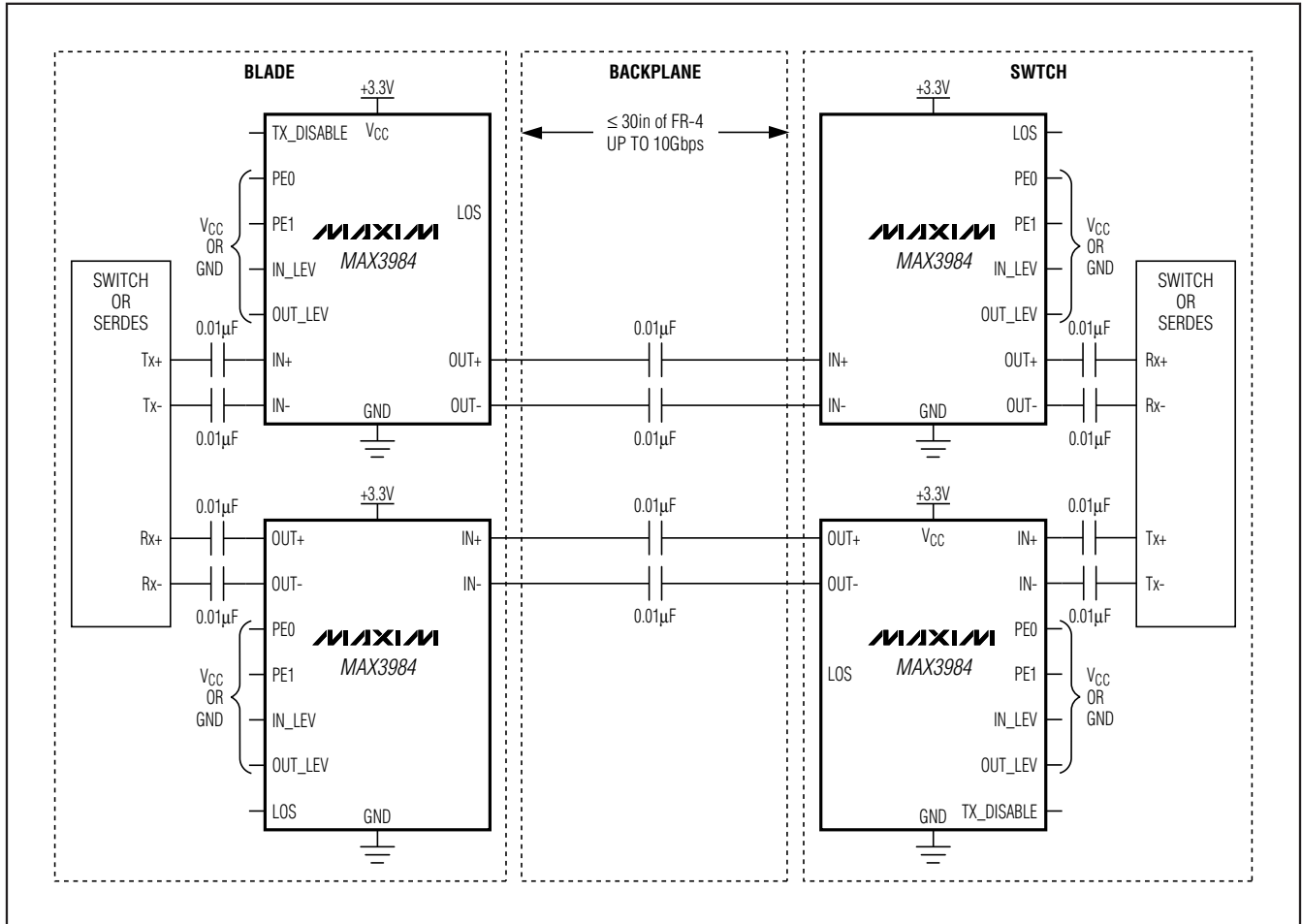

Figure 8. Loss-of-Signal Equivalent Output Structure

# 1Gbps to 10Gbps Preemphasis Driver with Receive Equalizer

## Typical Operating Circuits (continued)

MAX3984



# 1Gbps to 10Gbps Preemphasis Driver with Receive Equalizer

## Pin Configuration

## Chip Information

PROCESS: SiGe Bipolar

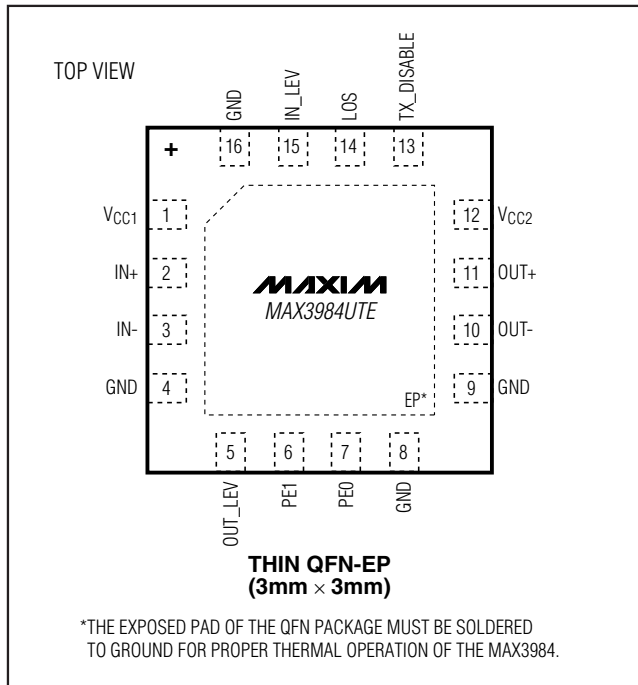

# 1Gbps to 10Gbps Preemphasis Driver with Receive Equalizer

## Package Information

(The package drawing(s) in this data sheet may not reflect the most current specifications. For the latest package outline information go to [www.maxim-ic.com/packages](http://www.maxim-ic.com/packages).)

**MAX3984**

12X16L QFN THIN LEPS

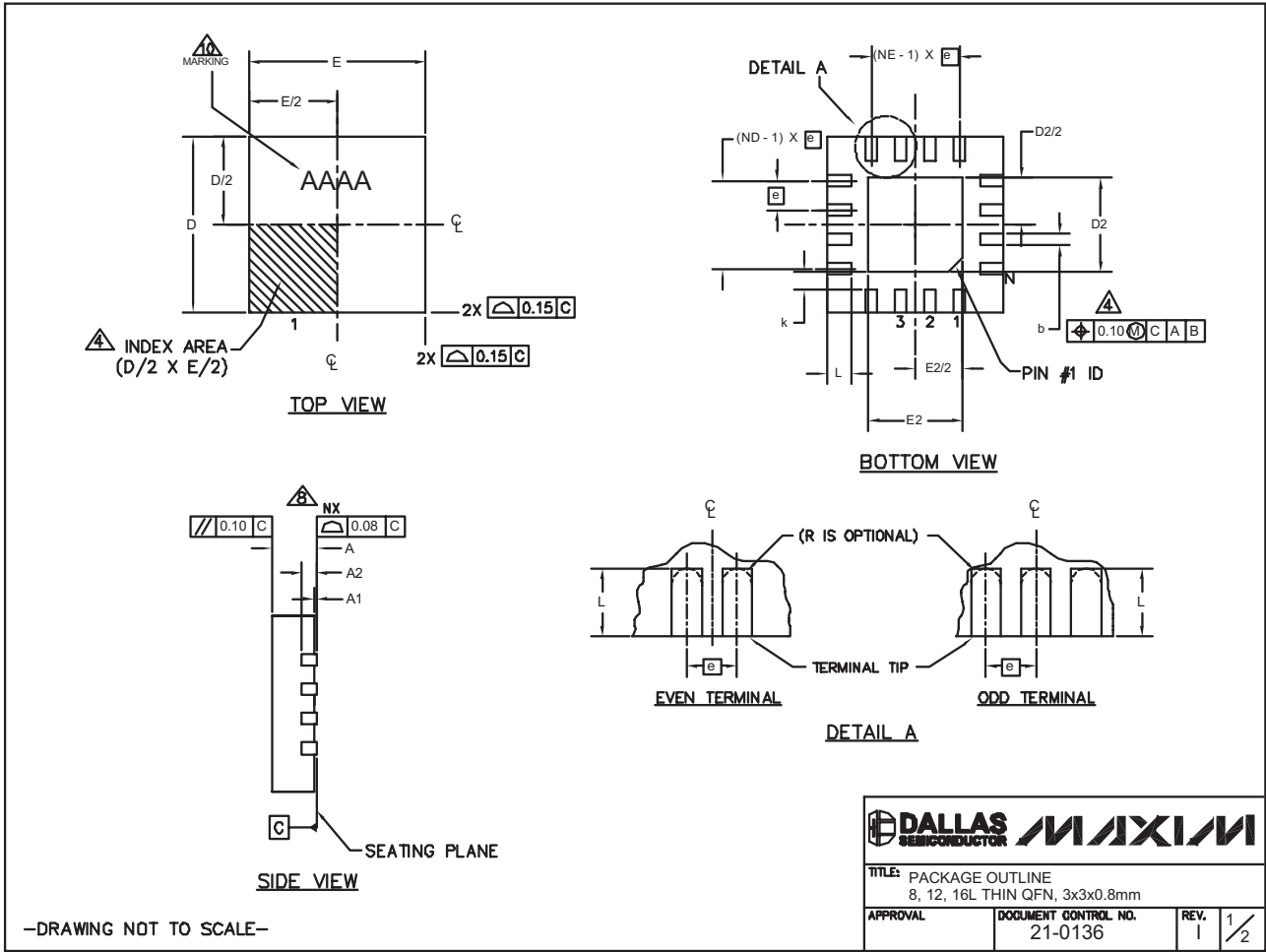

-DRAWING NOT TO SCALE-

# 1Gbps to 10Gbps Preemphasis Driver with Receive Equalizer

## Package Information (continued)

(The package drawing(s) in this data sheet may not reflect the most current specifications. For the latest package outline information go to [www.maxim-ic.com/packages](http://www.maxim-ic.com/packages).)

PKG	8L 3x3			12L 3x3			16L 3x3		
REF.	MIN.	NOM.	MAX.	MIN.	NOM.	MAX.	MIN.	NOM.	MAX.
A	0.70	0.75	0.80	0.70	0.75	0.80	0.70	0.75	0.80
b	0.25	0.30	0.35	0.20	0.25	0.30	0.20	0.25	0.30
D	2.90	3.00	3.10	2.90	3.00	3.10	2.90	3.00	3.10
E	2.90	3.00	3.10	2.90	3.00	3.10	2.90	3.00	3.10
e	0.65 BSC.			0.50 BSC.			0.50 BSC.		
L	0.35	0.55	0.75	0.45	0.55	0.65	0.30	0.40	0.50
N	8			12			16		
ND	2			3			4		
NE	2			3			4		
A1	0	0.02	0.05	0	0.02	0.05	0	0.02	0.05
A2	0.20 REF			0.20 REF			0.20 REF		
k	0.25	-	-	0.25	-	-	0.25	-	-

EXPOSED PAD VARIATIONS								
PKG CODES	D2			E2			PIN ID	JEDEC
	MIN.	NOM.	MAX.	MIN.	NOM.	MAX.		
TQ833-1	0.25	0.70	1.25	0.25	0.70	1.25	0.35 x 45°	WEEC
T1233-1	0.95	1.10	1.25	0.95	1.10	1.25	0.35 x 45°	WEED-1
T1233-3	0.95	1.10	1.25	0.95	1.10	1.25	0.35 x 45°	WEED-1
T1233-4	0.95	1.10	1.25	0.95	1.10	1.25	0.35 x 45°	WEED-1
T1633-2	0.95	1.10	1.25	0.95	1.10	1.25	0.35 x 45°	WEED-2
T1633F-3	0.65	0.80	0.95	0.65	0.80	0.95	0.225 x 45°	WEED-2
T1633FH-3	0.65	0.80	0.95	0.65	0.80	0.95	0.225 x 45°	WEED-2
T1633-4	0.95	1.10	1.25	0.95	1.10	1.25	0.35 x 45°	WEED-2
T1633-5	0.95	1.10	1.25	0.95	1.10	1.25	0.35 x 45°	WEED-2

**NOTES:**

1. DIMENSIONING & TOLERANCING CONFORM TO ASME Y14.5M-1994.
2. ALL DIMENSIONS ARE IN MILLIMETERS. ANGLES ARE IN DEGREES.
3. N IS THE TOTAL NUMBER OF TERMINALS.
- ⚠ THE TERMINAL #1 IDENTIFIER AND TERMINAL NUMBERING CONVENTION SHALL CONFORM TO JESD 95-1 SPP-012. DETAILS OF TERMINAL #1 IDENTIFIER ARE OPTIONAL, BUT MUST BE LOCATED WITHIN THE ZONE INDICATED. THE TERMINAL #1 IDENTIFIER MAY BE EITHER A MOLD OR MARKED FEATURE.
- ⚠ DIMENSION b APPLIES TO METALLIZED TERMINAL AND IS MEASURED BETWEEN 0.20 mm AND 0.25 mm FROM TERMINAL TIP.
- ⚠ ND AND NE REFER TO THE NUMBER OF TERMINALS ON EACH D AND E SIDE RESPECTIVELY.
7. DEPOPULATION IS POSSIBLE IN A SYMMETRICAL FASHION.
- ⚠ COPLANARITY APPLIES TO THE EXPOSED HEAT SINK SLUG AS WELL AS THE TERMINALS.
9. DRAWING CONFORMS TO JEDEC MO220 REVISION C.
- ⚠ MARKING IS FOR PACKAGE ORIENTATION REFERENCE ONLY.
11. NUMBER OF LEADS SHOWN ARE FOR REFERENCE ONLY.
12. WARPAGE NOT TO EXCEED 0.10mm.

-DRAWING NOT TO SCALE-

		
<b>TITLE:</b> PACKAGE OUTLINE 8, 12, 16L THIN QFN, 3x3x0.8mm		
<b>APPROVAL</b>	<b>DOCUMENT CONTROL NO.</b> 21-0136	<b>REV.</b> 1 <span style="float: right;">2/2</span>

Maxim cannot assume responsibility for use of any circuitry other than circuitry entirely embodied in a Maxim product. No circuit patent licenses are implied. Maxim reserves the right to change the circuitry and specifications without notice at any time.

18 **Maxim Integrated Products, 120 San Gabriel Drive, Sunnyvale, CA 94086 408-737-7600**