



Chipsmall Limited consists of a professional team with an average of over 10 year of expertise in the distribution of electronic components. Based in Hongkong, we have already established firm and mutual-benefit business relationships with customers from,Europe,America and south Asia,supplying obsolete and hard-to-find components to meet their specific needs.

With the principle of “Quality Parts,Customers Priority,Honest Operation,and Considerate Service”,our business mainly focus on the distribution of electronic components. Line cards we deal with include Microchip,ALPS,ROHM,Xilinx,Pulse,ON,Everlight and Freescale. Main products comprise IC,Modules,Potentiometer,IC Socket,Relay,Connector.Our parts cover such applications as commercial,industrial, and automotives areas.

We are looking forward to setting up business relationship with you and hope to provide you with the best service and solution. Let us make a better world for our industry!



Contact us

Tel: +86-755-8981 8866 Fax: +86-755-8427 6832

Email & Skype: info@chipsmall.com Web: www.chipsmall.com

Address: A1208, Overseas Decoration Building, #122 Zhenhua RD., Futian, Shenzhen, China



General Description

The MAX40000 and MAX40001 evaluation kits (EV kits) are fully assembled and tested PC boards that evaluate the MAX40000 and MAX40001 single comparators with internal voltage references, respectively. By default, the MAX40001 EV kit has an open-drain output, while the MAX40000 EV kit has a push-pull output. These EV kits come with a MAX40000ANT12+/MAX40001ANT12+ installed that operate off a V_{CC} supply between 1.7V and 5.5V, an internal reference voltage of 1.252V, and have a wide -0.2V to +5.7V input voltage (V_{IN}) range. These EV kits demonstrate the MAX40000ANT12+/MAX40001ANT12+ in an ultra-small, 1.1mm x 0.76mm, 6-bump wafer-level package (WLP) with 0.35mm bump spacing.

These EV kits can be used to evaluate the entire family of MAX40000/MAX40001 with 6-bump WLP options. Remove pullup resistor R3 on the MAX40001 EV kit when evaluating the MAX40000 in place of the default MAX40001 IC included in the MAX40001 EV kit.

Features

- -0.2V to V_{DD} + 0.2 Input Voltage Range
- 1.7V to 5.5V V_{DD} Range with Internal Reference
 - 1.252V, 1.66V, 1.94V, and 2.22V Internal Voltage Reference Options Available (V_{DD} min Depends on the Voltage Reference Option)

Note: Refer to the Electrical Characteristics table of the MAX40000 IC data sheet for more information on minimum V_{DD} .

- Configured to Add External Hysteresis
- Evaluates 6-Bump WLP
- Proven PCB Layout
- Fully Assembled and Tested

Quick Start

Required Equipment

Before beginning, the following equipment is needed:

- Three +5V DC power supplies (V_{DD} , INP, and V_{PULL} on MAX40001EVKIT)
- Two digital multimeters (DMMs)

Ordering Information appears at end of data sheet.

Procedure

The MAX40000/MAX40001 EV kits are fully assembled and tested. Follow steps below to verify board operation. **Caution: Do not turn on the power supply until all connections are completed. By default, the MAX40000 EV kit comes with the MAX40000ANT12+.**

- 1) Connect the positive terminal of a DC power supply to the VDD test point and the ground terminal to the GND test point.
- 2) Connect the positive terminal of a DC power supply to the VPULL test point and the ground terminal to the GND test point (not applicable for the MAX40000 EV kit). This is not necessary while evaluating the MAX40000 on the MAX40001 EV kit. R3 needs to be removed while using MAX40001 EV kit to evaluate the MAX40000 push-pull version.
- 3) Connect the positive terminal of a DC power supply to the INP test point and the ground terminal to the GND test point.
- 4) Use a wire to short INM test point and V_{REF} test point to connect voltage reference output (1.252V, default) to inverting input.
- 5) Turn on the V_{CC} power supply and set it to any voltage between 1.7V to 5.5V.
- 6) Monitor the output voltage at the VREF test point using DMM. This should be 1.252V (default) when either the MAX40000ANT12+/MAX40001ANT12+ is used.
- 7) Turn on the V_{PULL} power supply and set it to any voltage between 1.7V to 5.5V (MAX40001 only). Do not need V_{PULL} supply when MAX40000 (push-pull output) is used on the MAX40001 EV kit.
- 8) Turn on the INP power supply and set it to the desired level.
- 9) Monitor the output using a DMM at the VOUT test point and study its response to varying voltage at INP. Ideally, voltage at the VOUT test point of the MAX40001 EV kit should be at logic-high (V_{PULL}) when voltage applied on INP is greater than 1.252V and should be at logic-low (0V) when voltage applied on INP is less than 1.252V.
- 10) While, on the MAX40000 EV kit, the voltage on the VOUT test point will be at V_{CC} when the voltage on INP is greater than 1.252V, it should be at GND when the voltage applied on INP is less than 1.252.

Detailed Description of Hardware

The MAX40000/MAX40001 EV kits are fully assembled and tested PC boards that evaluate the 6-bump WLP MAX40000ANT12+/MAX40001ANT12+ push-pull/open-drain output comparators, respectively. These EV kits require a 1.7V to 5.5V supply voltage for normal operation and can be used to evaluate all other MAX40000/MAX40001 parts that come with a WLP.

These EV kits allow users to add external hysteresis in addition to the 4mV internal hysteresis through the addition of appropriate resistors on the R2 and R1 pads provided on the EV board. The amount of hysteresis added is given by the equation below, based on R1, R2 values:

$$\text{Hysteresis} = \frac{R1}{R2} \times VCC$$

These EV kits also allow users to apply an internal voltage reference to either the IP or IN input pins of the comparator by installing resistor components on R4, R5, and R6 pads. R4 and R5 resistor combination can be used if a voltage-divided version voltage of internal voltage reference is needed in the application.

Table 1. Default Jumper Settings

JUMPER	SHUNT POSITION
J1 (MAX40001EVKIT Only)	Installed
J2	Not Installed

The VPULL test point on the MAX40001 EV kit is utilized to apply a pullup supply voltage between 1.7V to 5.5V for the open-drain output devices for proper operation. Remove R3 and eliminate VPULL if evaluating the comparators with the push-pull output (MAX40000) on the MAX40001 EV kit.

The MAX40000 EV kit, by default, comes with the MAX40000ANT12+. If the user would like to evaluate the MAX40001 on the MAX40000 EV kit, the user should provide a pullup resistor to supply voltage on the VOUT test point.

The MAX40001 EV kit, by default, comes with the MAX40001ANT12+. If the user would like to evaluate the MAX40000 on the MAX40001 EV kit, the user should remove jumper J1 to the pullup resistor on the output pin.

MAX40000/MAX40001 EV Kit Schematics

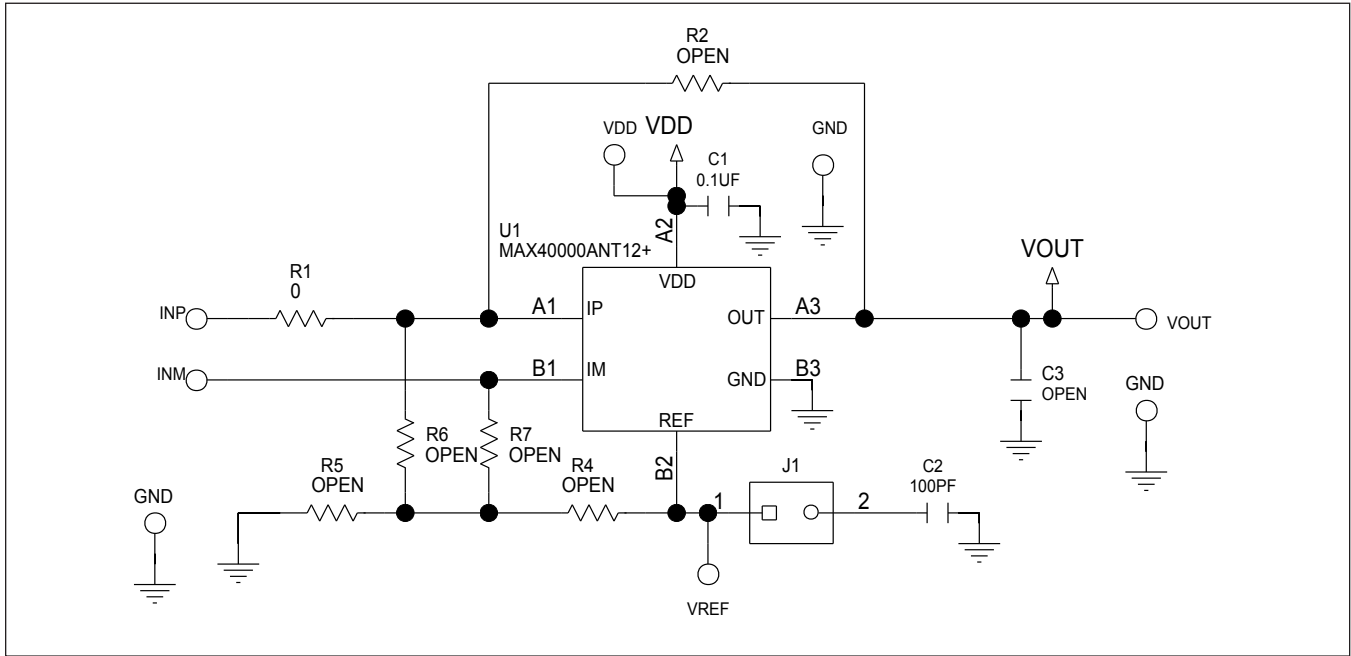

MAX40000 EV Kit Schematic

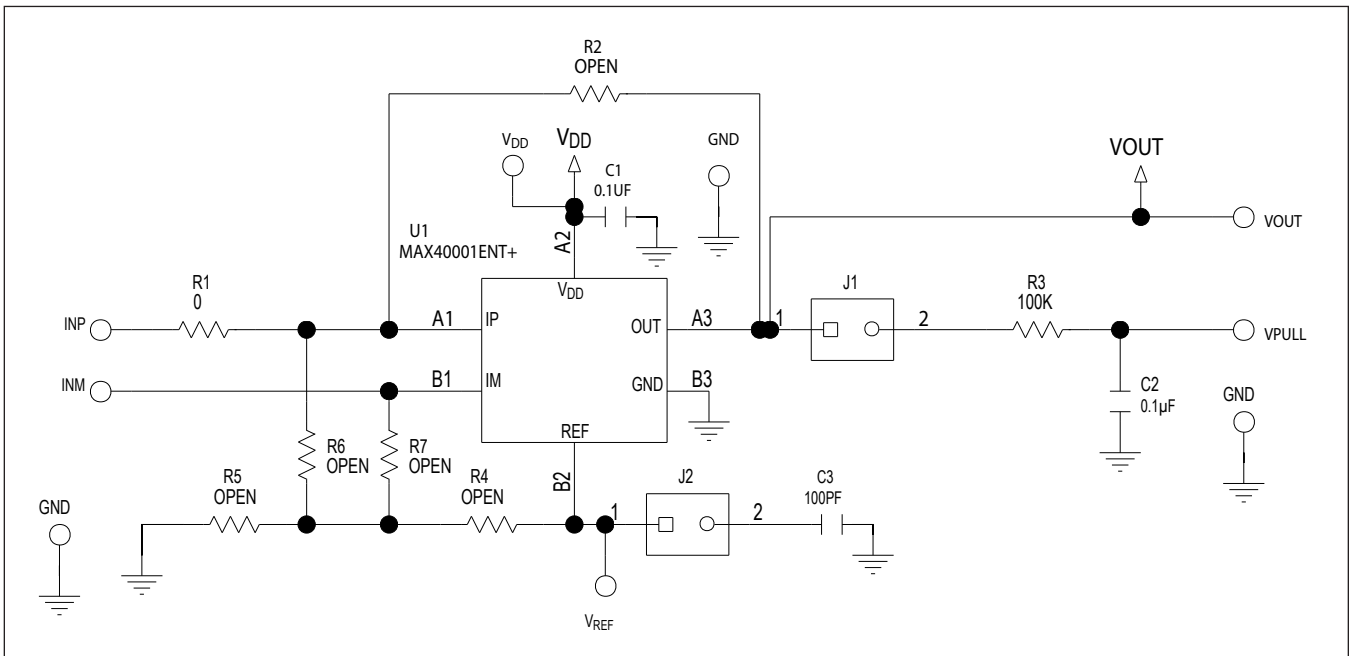

MAX40001 EV Kit Schematic

MAX40000 EV Kit PCB Layout Diagrams

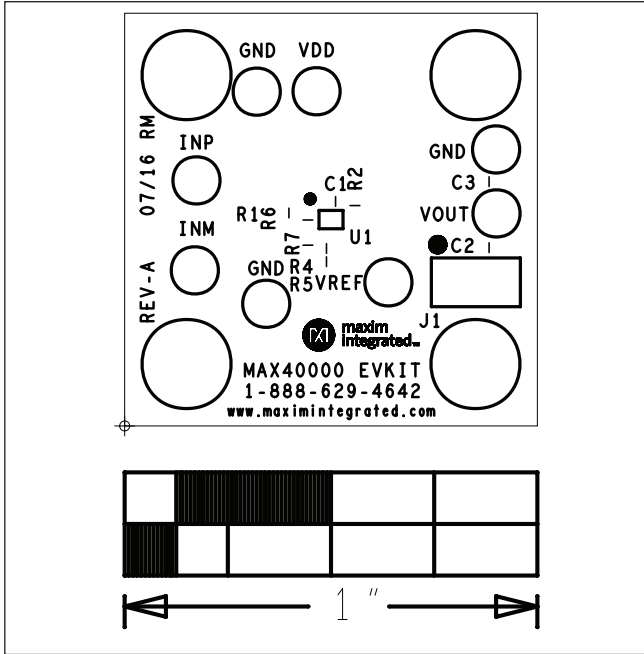

MAX40000 EV Kit—Top Silkscreen

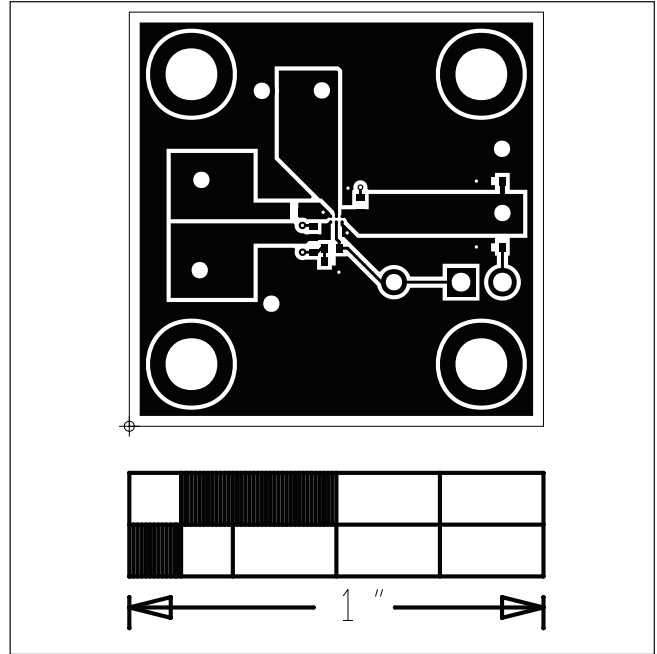

MAX40000 EV Kit—Top

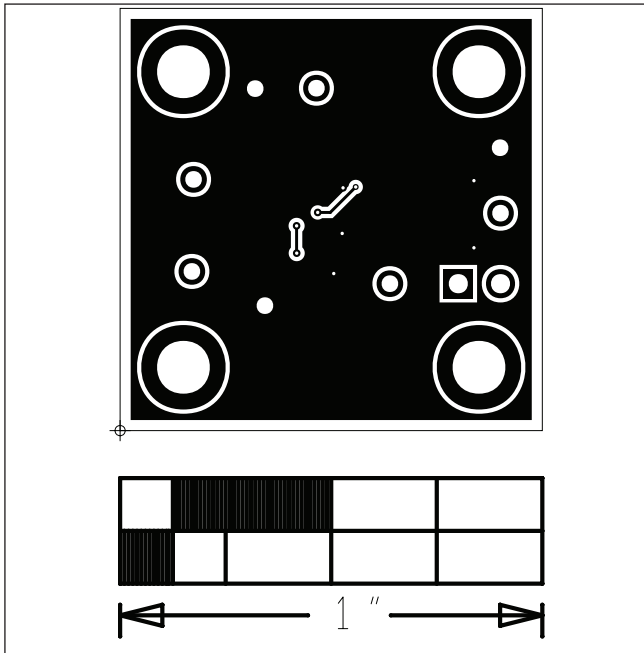

MAX40000 EV Kit—Bottom

MAX40000 EV Kit PCB Layout Diagrams (continued)

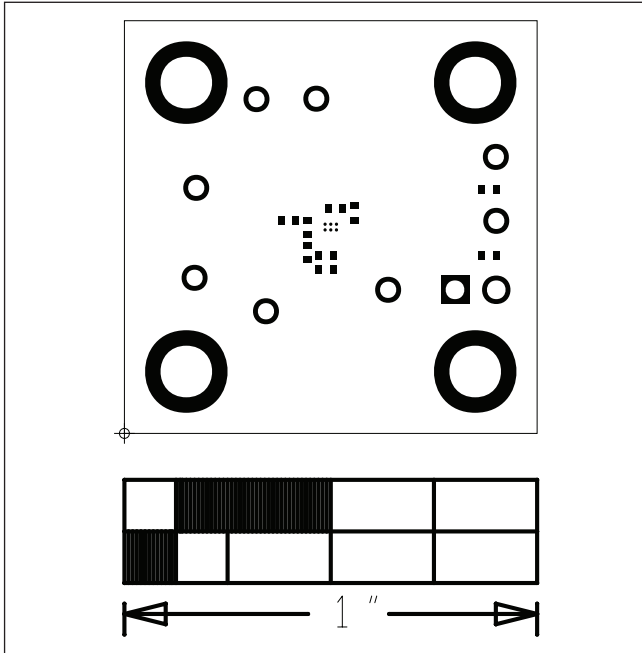

MAX40000 EV Kit—Top Mask

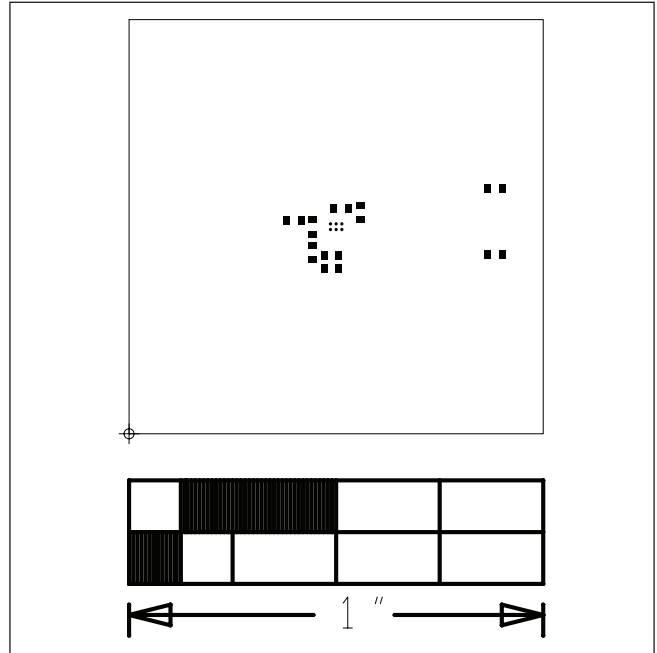

MAX40000 EV Kit—Top Paste

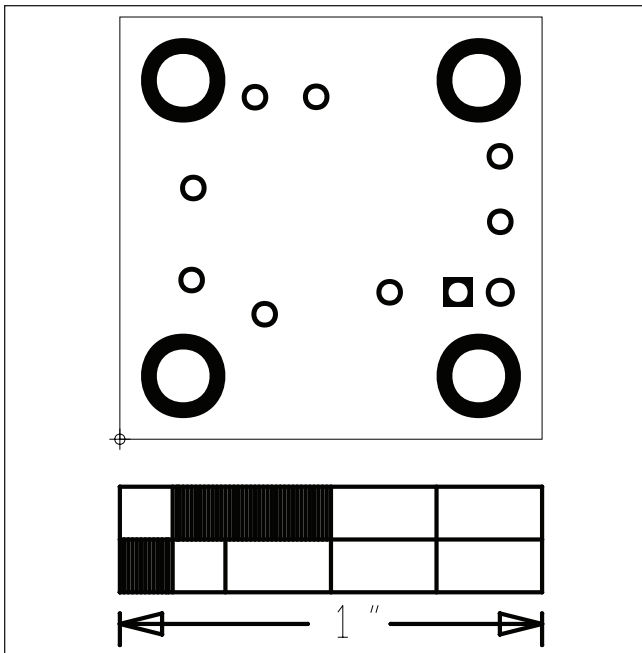

MAX40000 EV Kit—Bottom Mask

MAX40001 EV Kit PCB Layout Diagrams

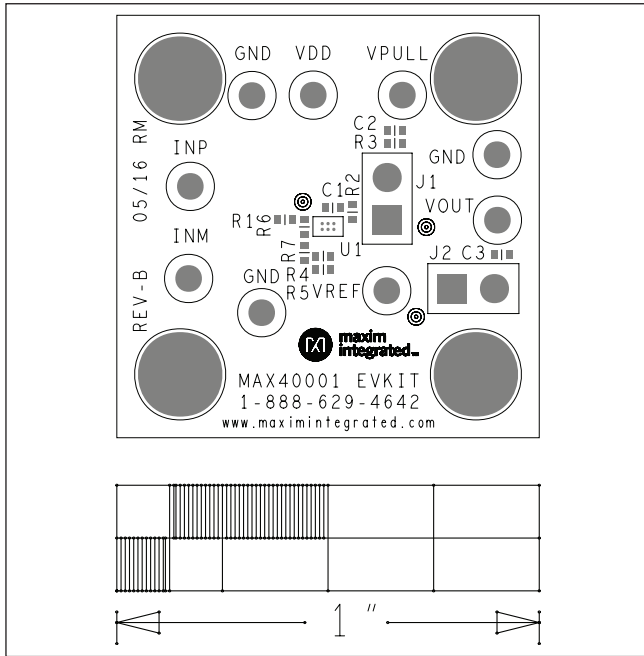

MAX40001 EV Kit—Top Silkscreen

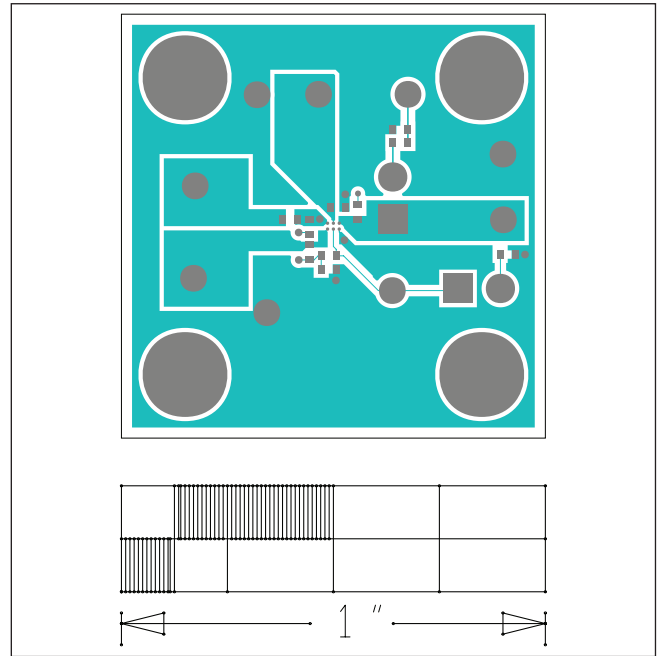

MAX40001 EV Kit—Top

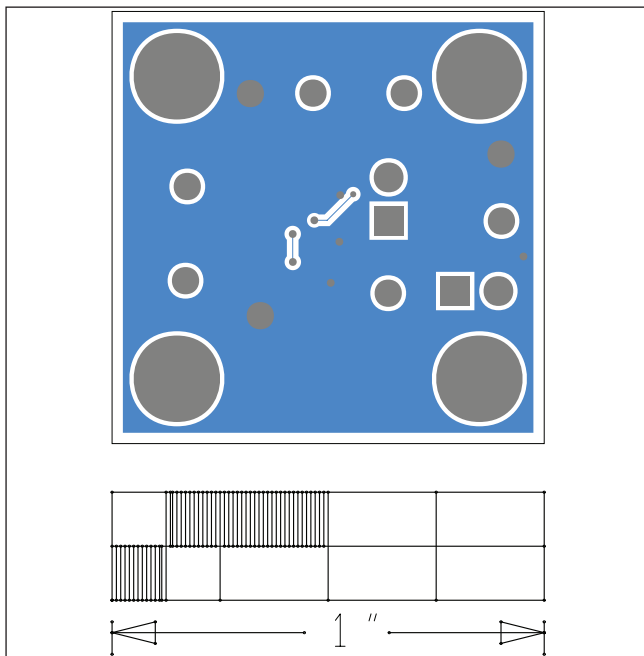

MAX40001 EV Kit—Bottom

Ordering Information

PART	TYPE
MAX40000EVKIT#	EV Kit
MAX40001EVKIT#	EV Kit

#Denotes RoHS compliant.

Revision History

REVISION NUMBER	REVISION DATE	DESCRIPTION	PAGES CHANGED
0	8/16	Initial release	—
1	10/16	Added MAX40000 part number, schematic, and PCB layout diagrams	1-7
2	6/17	Removed future product asterisk from MAX40001EVKIT#	6

For pricing, delivery, and ordering information, please contact Maxim Direct at 1-888-629-4642, or visit Maxim Integrated's website at www.maximintegrated.com.

Maxim Integrated cannot assume responsibility for use of any circuitry other than circuitry entirely embodied in a Maxim Integrated product. No circuit patent licenses are implied. Maxim Integrated reserves the right to change the circuitry and specifications without notice at any time.