



Chipsmall Limited consists of a professional team with an average of over 10 year of expertise in the distribution of electronic components. Based in Hongkong, we have already established firm and mutual-benefit business relationships with customers from,Europe,America and south Asia,supplying obsolete and hard-to-find components to meet their specific needs.

With the principle of "Quality Parts,Customers Priority,Honest Operation,and Considerate Service",our business mainly focus on the distribution of electronic components. Line cards we deal with include Microchip,ALPS,ROHM,Xilinx,Pulse,ON,Everlight and Freescale. Main products comprise IC,Modules,Potentiometer,IC Socket,Relay,Connector.Our parts cover such applications as commercial,industrial, and automotives areas.

We are looking forward to setting up business relationship with you and hope to provide you with the best service and solution. Let us make a better world for our industry!



Contact us

Tel: +86-755-8981 8866 Fax: +86-755-8427 6832

Email & Skype: info@chipsmall.com Web: www.chipsmall.com

Address: A1208, Overseas Decoration Building, #122 Zhenhua RD., Futian, Shenzhen, China



MAXIM

MAX4278 Evaluation Kit

Evaluates: MAX4178/MAX4278

General Description

The MAX4278 evaluation kit (EV kit) simplifies evaluation of the MAX4178/MAX4278 330MHz/310MHz high-speed buffers. RF-style connectors (SMA) and 75Ω terminating resistors are included for video test equipment compatibility.

The EV kit comes with the MAX4278 installed. To evaluate the MAX4178, simply order a free sample (MAX4178ESA) and replace the MAX4278 with the MAX4178. No other changes are necessary.

Component List

DESIGNATION	QTY	DESCRIPTION
U1	1	Maxim MAX4278ESA
C1, C6	2	10μF, 10V, 20% tantalum capacitors AVX TAJB106M010 or Sprague 293D106X0010B
C2, C5	2	0.1μF, 10% ceramic capacitors Vitraron VJ1206Y104KXX
C3, C4	2	1000pF, 10% ceramic capacitors Vitraron VJ1206Y102KXX
R1, R2	2	75Ω, 5% resistors
RG	1	0Ω resistor
IN, OUT	2	SMA connectors
None	1	High-frequency amplifier PC board

Component Suppliers

SUPPLIER	PHONE	FAX
AVX	(803) 946-0690	(803) 626-3123
Sprague	(603) 224-1961	(603) 224-1430
Vishay/Vitraron	(203) 268-6261	(203) 452-5670

Features

- ◆ 310MHz -3dB Bandwidth
- ◆ 75Ω Terminated Input and Output
- ◆ Fully Assembled and Tested

Ordering Information

PART	TEMP. RANGE	BOARD TYPE
MAX4278EVKIT-SO	+25°C	Surface Mount

Note: To evaluate the MAX4178, request a MAX4178ESA free sample.

Quick Start

The MAX4278 evaluation kit is fully assembled and tested. Follow these steps to verify board operation. **Do not turn on the power supply until all connections are completed.**

- 1) The circuit requires supply voltages of ±5V. Connect the +5V supply to the V+ pad, and the -5V supply to the V- pad. Connect the power-supply ground to the pad marked GND.
- 2) Apply a signal of ±1.5V maximum to the SMA connector marked IN.
- 3) Connect the output marked OUT to an oscilloscope through a terminated 75Ω cable.
- 4) Turn on the power supply and verify the output signal on the oscilloscope.

MAX4278 Evaluation Kit

Detailed Description

Shutdown Control

Although the EV kit provides shutdown control circuitry (J1) for other amplifiers, the MAX4278 and MAX4178 do not have a shutdown feature. Therefore, pin 8 is not connected.

Layout Considerations

The MAX4278 EV kit layout is optimized for high-speed signals. Careful attention was given to grounding, power-supply bypassing, and signal path layout. Small,

surface-mount ceramic capacitors are placed as close to the MAX4278 supply pins as possible. The N.C. pins (pins 1 and 5) are grounded to prevent unwanted noise from coupling into the circuit. Refer to the *Grounding, Bypassing, and PC Board Layout* section of the MAX4178/MAX4278 data sheet for further details.

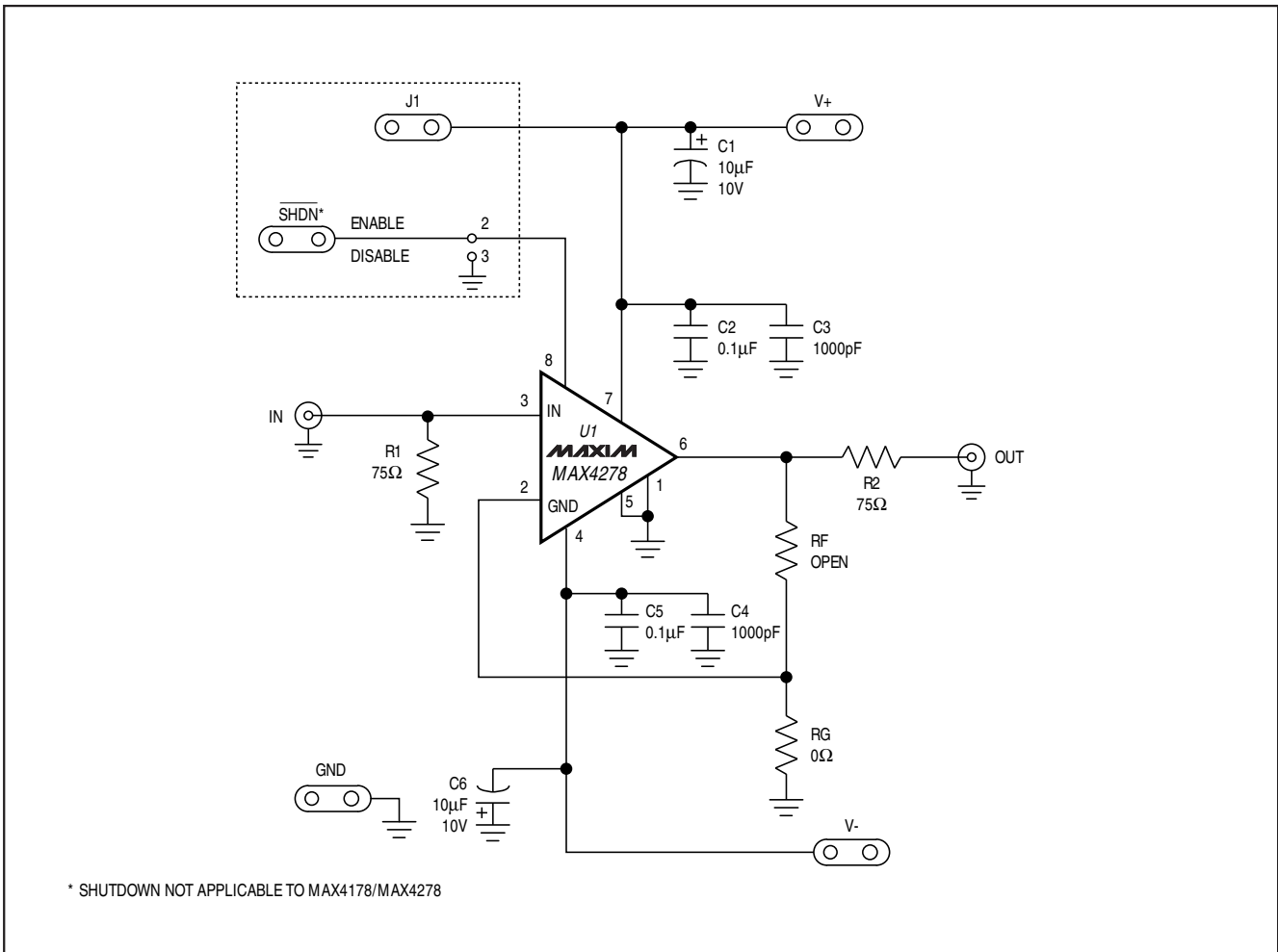

Figure 1. MAX4278 EV Kit Schematic

MAX4278 Evaluation Kit

Evaluates: MAX4178/MAX4278

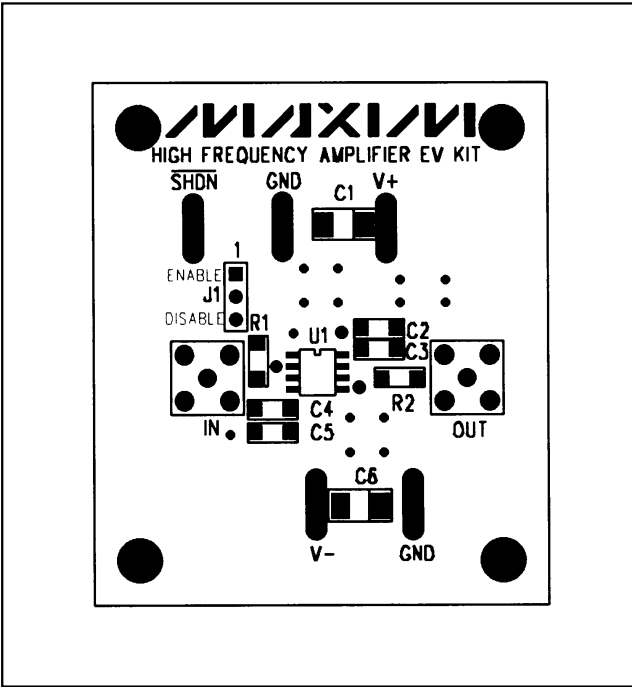

Figure 2. MAX4278 EV Kit Component Placement Guide—Component Side

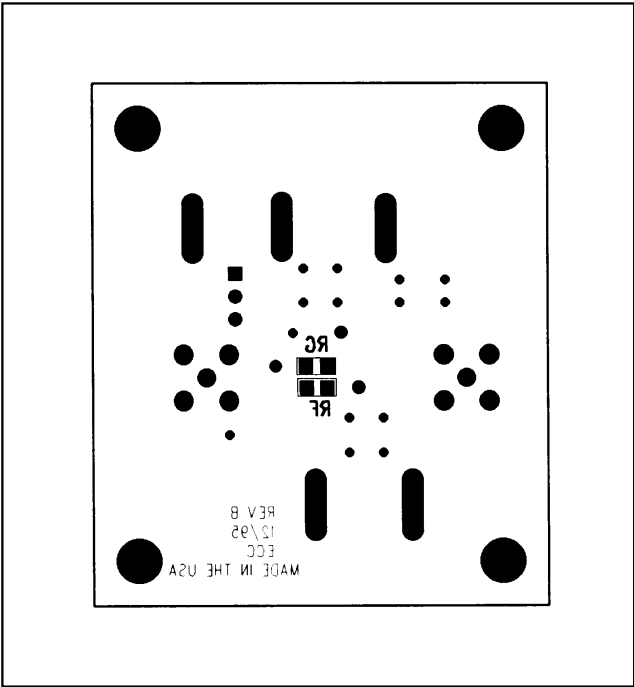

Figure 3. MAX4278 EV Kit Component Placement Guide—Solder Side

MAX4278 Evaluation Kit

Evaluates: MAX4178/MAX4278

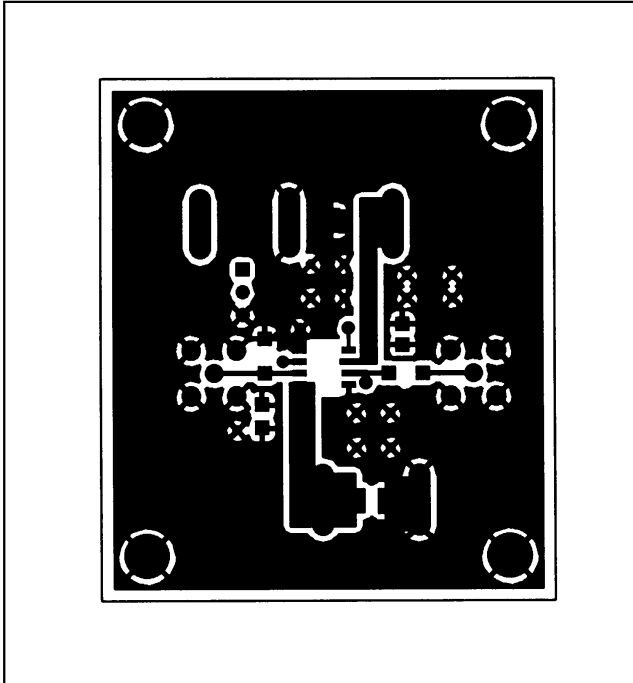

Figure 4. MAX4278 EV Kit PC Board Layout—Component Side

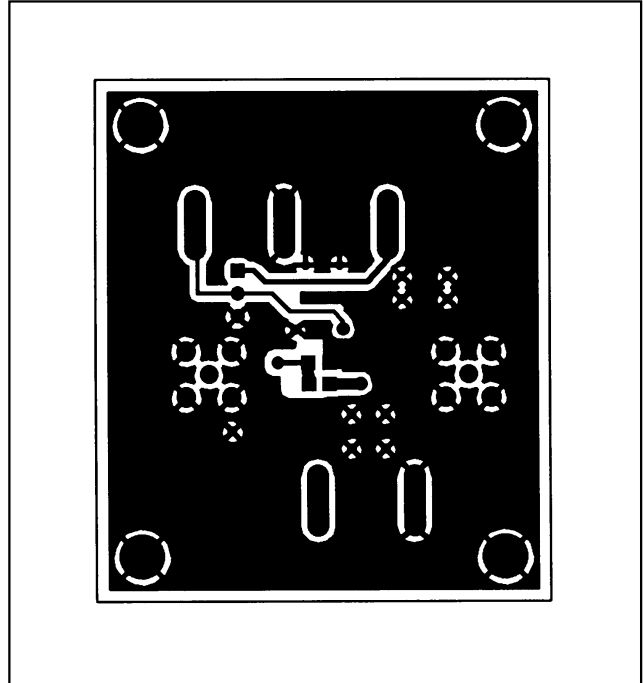

Figure 5. MAX4278 EV Kit Board Layout—Solder Side

Maxim cannot assume responsibility for use of any circuitry other than circuitry entirely embodied in a Maxim product. No circuit patent licenses are implied. Maxim reserves the right to change the circuitry and specifications without notice at any time.

4 _____ Maxim Integrated Products, 120 San Gabriel Drive, Sunnyvale, CA 94086 408-737-7600

© 1997 Maxim Integrated Products

Printed USA

MAXIM is a registered trademark of Maxim Integrated Products.