



Chipsmall Limited consists of a professional team with an average of over 10 year of expertise in the distribution of electronic components. Based in Hongkong, we have already established firm and mutual-benefit business relationships with customers from,Europe,America and south Asia,supplying obsolete and hard-to-find components to meet their specific needs.

With the principle of “Quality Parts,Customers Priority,Honest Operation,and Considerate Service”,our business mainly focus on the distribution of electronic components. Line cards we deal with include Microchip,ALPS,ROHM,Xilinx,Pulse,ON,Everlight and Freescale. Main products comprise IC,Modules,Potentiometer,IC Socket,Relay,Connector.Our parts cover such applications as commercial,industrial, and automotives areas.

We are looking forward to setting up business relationship with you and hope to provide you with the best service and solution. Let us make a better world for our industry!



Contact us

Tel: +86-755-8981 8866 Fax: +86-755-8427 6832

Email & Skype: info@chipsmall.com Web: www.chipsmall.com

Address: A1208, Overseas Decoration Building, #122 Zhenhua RD., Futian, Shenzhen, China



General Description

The MAX44284 evaluation kit (EV kit) provides a proven design to evaluate the MAX44284 high-precision, low-power, current-sense amplifier. This EV kit demonstrates the MAX44284 in an ultra-small, 1.3mm x 0.9mm, 6-bump WLP package.

The EV kit PCB comes with a MAX44284HAWT+ installed, which is the 100V/V gain version. Other gain options are available. Contact the factory for the pin-compatible MAX44284FAWT+ (G = 50V/V), MAX44284WAWT+ (200V/V), and MAX44284EAWT+ (G = 500V/V).

EV Kit Contents

- MAX44284 EV Kit Board

Features and Benefits

- Precision Real-Time Current Monitoring
- -0.1V to +36V Input Common-Mode Range
- Proven PCB Layout
- Fully Assembled and Tested

[Ordering Information](#) appears at end of data sheet.

Quick Start

Required Equipment

The following items are required for operation:

- MAX44284 EV kit
- +3.3V, 1.5A DC power supply
- +2.7, 1A DC power supply
- An electronic load capable of sinking 1A (i.e., HP6060B)
- Two digital voltmeters

Procedure

The MAX44284 EV kit is fully assembled and tested. Follow the steps below to verify the board operation.

Caution: Do not turn on power supply or the electronic load until all connections are made.

- 1) Connect the positive terminal of the +3.3V supply to the VDD test point and the negative terminal of the supply to the nearest GND test point.
- 2) Connect the positive terminal of the +2.7V supply to the VBATT test point and the negative terminal of the supply to the nearest GND test point.
- 3) Set the electronic load to sink 650mA.
- 4) Connect the positive terminal of the electronic load to the LOAD test point and the negative terminal of the supply to the nearest GND test point.
- 5) Connect the first voltmeter between test points RS+ and RS- to measure V_{SENSE} .
- 6) Connect the second voltmeter between VOUT and the nearest GND test points.
- 7) Turn on the power supplies.
- 8) Enable the electronic load.
- 9) Verify that the first voltmeter displays 33mV and the second voltmeter displays 3.3V.

Detailed Description of Hardware

The MAX44284 EV kit provides a proven design to evaluate the MAX44284 high-side, current-sense amplifier, which offers precision accuracy specifications of input offset voltage (V_{OS}) less than $2\mu V$ (max) and gain error less than 0.05% (max).

Applying the V_{RS+} Supply and the Load

The EV kit is installed with a MAX44284H, which has a 100V/V gain. The current-sense resistors (R_{SENSE}) value is 0.05Ω with $\pm 0.5\%$ tolerance. The V_{OUT} for each channel given by:

$$V_{OUT} = I_{LOAD} \times R_{SENSE} \times A_V$$

where A_V is the gain and I_{LOAD} is the current load applied to the device. Normal operating V_{RS+} and V_{RS-} range is $-0.1V$ to $+36V$.

Measuring the Load Current

The load current is measured as a voltage drop (V_{SENSE}) across an external sense resistor. This voltage is then amplified by the current-sense amplifier and presented at

its $V_{OUT_}$ pin. Like all differential amplifiers, the output voltage has two components of error (an offset error and a gain error). The offset error affects accuracy at low currents and a gain error affects accuracy at large currents—both errors affect accuracy at intermediate currents. By minimizing both offset and gain errors, accuracy can be optimized over a wide dynamic range.

\overline{SHDN}

To place the device into shutdown mode, install a shunt in the 2-3 position on jumper JU1. See Table 1 for shunt positions.

Table 1. \overline{SHDN} Jumper Description (JU1)

JUMPER	SHUNT POSITION	DESCRIPTION
JU1	1-2*	Normal operation
	2-3	\overline{SHDN} , MAX44284 is in shutdown mode

*Default position.

Component List

Refer to file “max44284_evkit_reva_parts checklist.xls” attached to this PDF for component information.

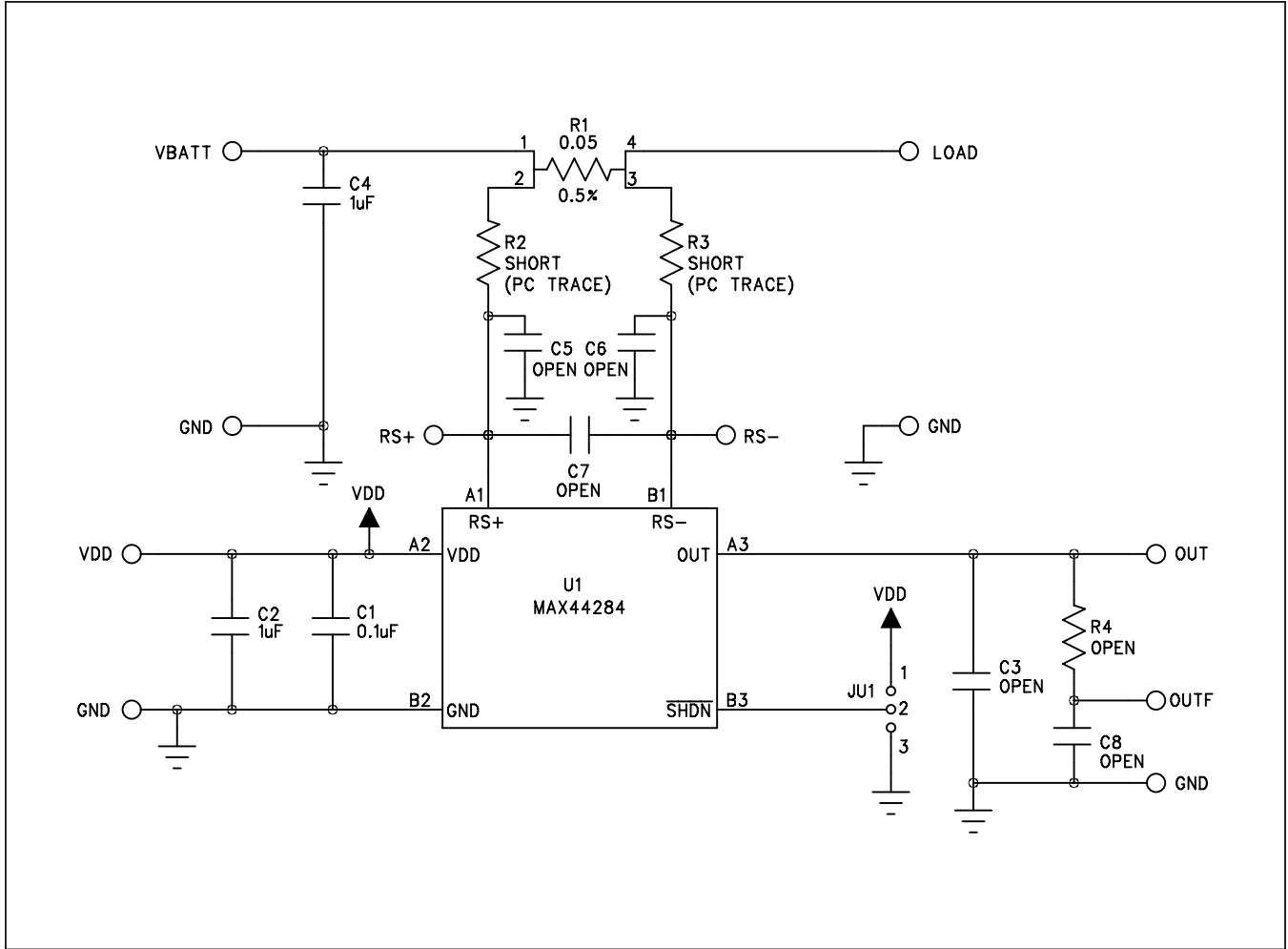

Figure 1. MAX44284 EV Kit Schematic

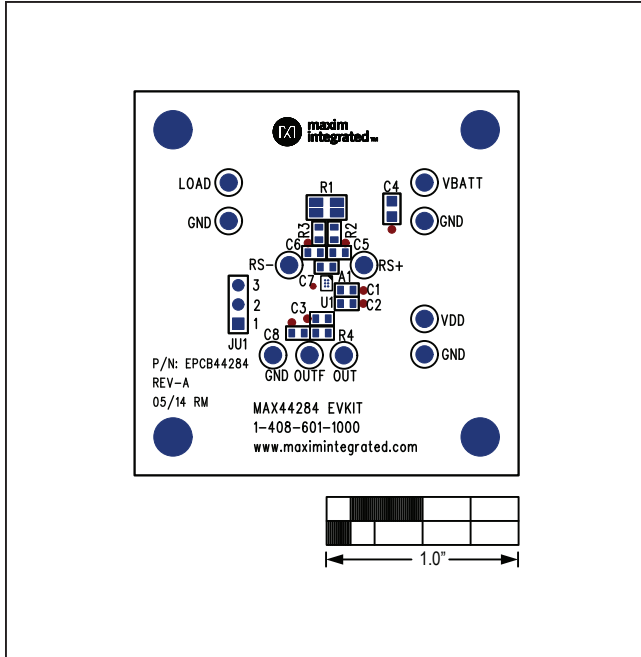

Figure 2. MAX44284 EV Kit Component Placement Guide—Component Side

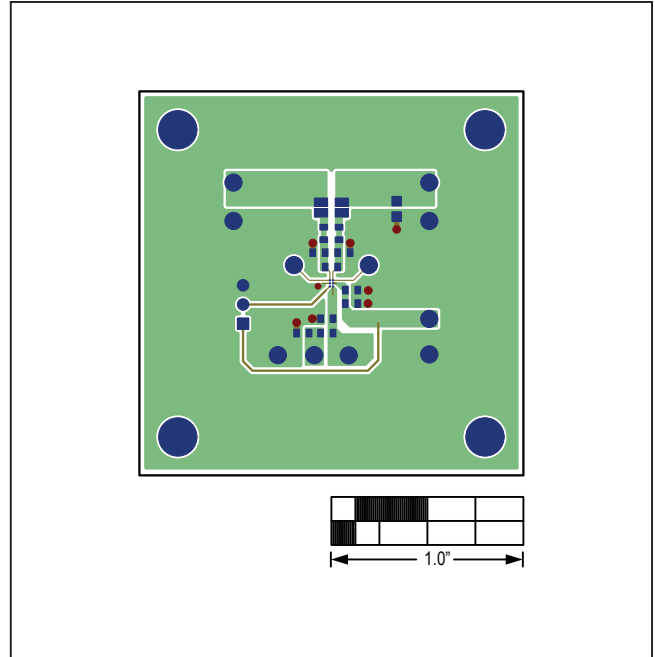

Figure 3. MAX44284 EV Kit PCB Layout—Component Side

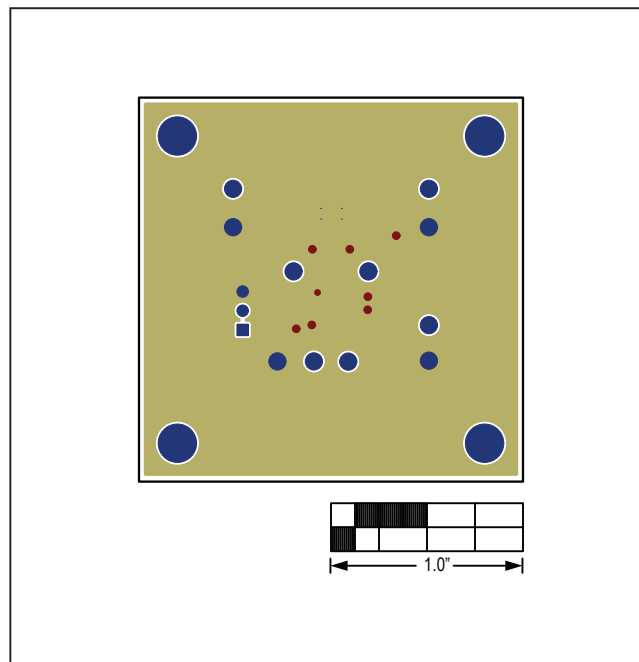

Figure 4. MAX44284 EV Kit PCB Layout—Solder Side

Ordering Information

PART	TYPE
MAX44284EVKIT#	EV Kit

#Denotes RoHS compliant.

Revision History

REVISION NUMBER	REVISION DATE	DESCRIPTION	PAGES CHANGED
0	7/14	Initial release	—

For pricing, delivery, and ordering information, please contact Maxim Direct at 1-888-629-4642, or visit Maxim Integrated's website at www.maximintegrated.com.

Maxim Integrated cannot assume responsibility for use of any circuitry other than circuitry entirely embodied in a Maxim Integrated product. No circuit patent licenses are implied. Maxim Integrated reserves the right to change the circuitry and specifications without notice at any time.