



Chipsmall Limited consists of a professional team with an average of over 10 year of expertise in the distribution of electronic components. Based in Hongkong, we have already established firm and mutual-benefit business relationships with customers from,Europe,America and south Asia,supplying obsolete and hard-to-find components to meet their specific needs.

With the principle of “Quality Parts,Customers Priority,Honest Operation,and Considerate Service”,our business mainly focus on the distribution of electronic components. Line cards we deal with include Microchip,ALPS,ROHM,Xilinx,Pulse,ON,Everlight and Freescale. Main products comprise IC,Modules,Potentiometer,IC Socket,Relay,Connector.Our parts cover such applications as commercial,industrial, and automotives areas.

We are looking forward to setting up business relationship with you and hope to provide you with the best service and solution. Let us make a better world for our industry!



Contact us

Tel: +86-755-8981 8866 Fax: +86-755-8427 6832

Email & Skype: info@chipsmall.com Web: www.chipsmall.com

Address: A1208, Overseas Decoration Building, #122 Zhenhua RD., Futian, Shenzhen, China



Low-Voltage 3.5Ω, SPDT, CMOS Analog Switches

General Description

The MAX4729/MAX4730 single-pole/double-throw (SPDT) switches operate from a single supply ranging from +1.8V to +5.5V. These switches provide low 3.5Ω on-resistance (RON), as well as 0.45Ω RON flatness with a +2.7V supply. These devices typically consume only 1nA of supply current, making them ideal for use in low-power, portable applications. The MAX4729/MAX4730 feature low-leakage currents over the extended temperature range, TTL/CMOS-compatible digital logic, and excellent AC characteristics.

The MAX4729/MAX4730 are available in small 6-pin SC70 and 6-pin μDFN packages. The MAX4729/MAX4730 are offered in three pinout configurations to ease design. The MAX4729/MAX4730 are specified over the extended -40°C to +85°C temperature range.

Features

- ◆ Low 3.5Ω RON (+2.7V Supply)
- ◆ 0.45Ω RON Flatness (+2.7V Supply)
- ◆ 0.05Ω RON Match Between Channels (+2.7V Supply)
- ◆ Tiny SC70 and μDFN Packages
- ◆ -3dB Bandwidth: 300MHz
- ◆ Low On-Capacitance: 19.5pF
- ◆ 0.036% Total Harmonic Distortion
- ◆ Low Supply Current: 1nA
- ◆ +1.8V to +5.5V Single-Supply Operation

Applications

Battery-Operated Equipment
 Audio and Video-Signal Routing
 Low-Voltage Data-Acquisition Systems
 Sample-and-Hold Circuits
 Communications Circuits
 Relay Replacement

Pin Configurations/Functional Diagrams/Truth Table

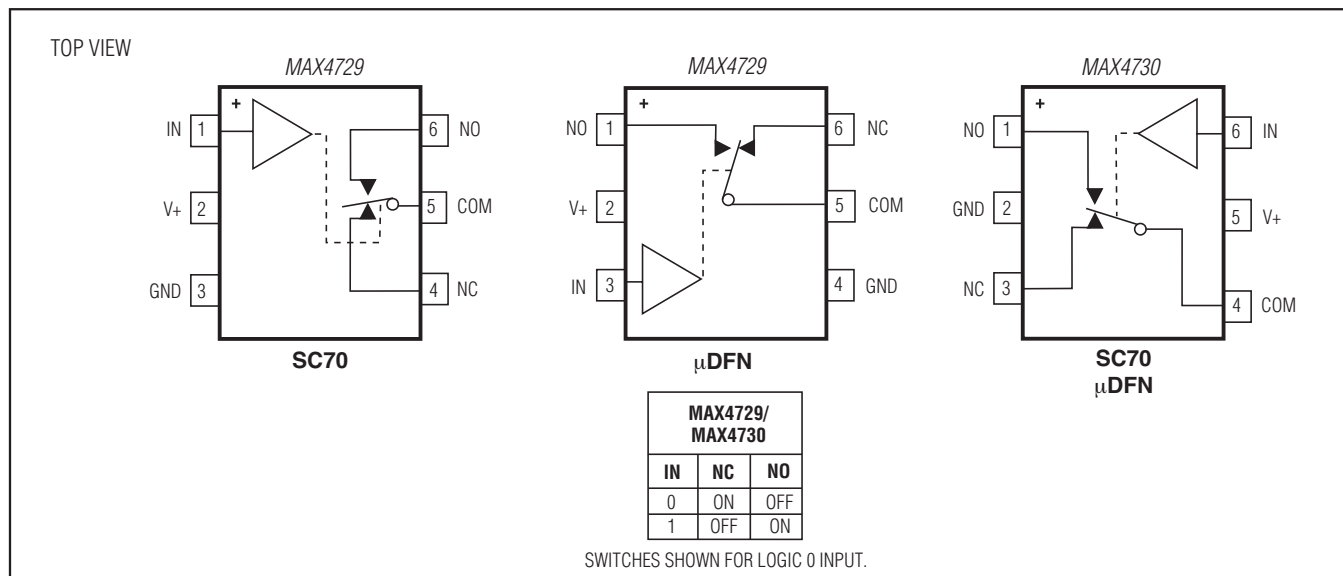

MAX4729/MAX4730

Low-Voltage 3.5Ω, SPDT, CMOS Analog Switches

ABSOLUTE MAXIMUM RATINGS

(All voltages referenced to ground.)

V+, IN	-0.3V to +6V
COM, NO, NC (Note 1)	-0.3V to (V+ +0.3V)
Continuous Current (IN, V+, GND)	±30mA
Continuous Current (COM, NO, NC)	±80mA
Peak Current COM, NO, NC (Pulsed at 1ms, 10% Duty Cycle)	±150mA

Continuous Power Dissipation (T _A = +70°C)	
μDFN (derate 2.1mW/°C above +70°C)	168mW
SC70 (derate 3.1mW/°C above +70°C)	245mW
Operating Temperature Range	-40°C to +85°C
Maximum Junction Temperature	+150°C
Storage Temperature Range	-65°C to +150°C
Lead Temperature (soldering, 10s)	+300°C
Soldering Temperature (reflow)	+260°C

Note 1: Signals on NO, NC, or COM exceeding V+ or GND are clamped by internal diodes. Signals on IN exceeding GND are clamped by an internal diode. Limit forward-diode current to maximum current rating.

Stresses beyond those listed under "Absolute Maximum Ratings" may cause permanent damage to the device. These are stress ratings only, and functional operation of the device at these or any other conditions beyond those indicated in the operational sections of the specifications is not implied. Exposure to absolute maximum rating conditions for extended periods may affect device reliability.

ELECTRICAL CHARACTERISTICS

(V+ = +2.7V to +3.6V, V_{IH} = +2.0V, V_{IL} = +0.4V, T_A = -40°C to +85°C, unless otherwise noted. Typical values are at T_A = +25°C.) (Note 2)

PARAMETER	SYMBOL	CONDITIONS	MIN	TYP	MAX	UNITS	
ANALOG SWITCH							
Analog Signal Range	V _{COM} , V _{NO} , V _{NC}		0		V+	V	
On-Resistance (Note 6)	R _{ON}	V+ = 2.7V, I _{COM} = 10mA, V _{NO} or V _{NC} = 0V to V+	T _A = +25°C	3.5	5.5	Ω	
			T _A = -40°C to +85		5.7		
On-Resistance Match Between Channels (Notes 3, 6)	ΔR _{ON}	V+ = 2.7V, I _{COM} = 10mA, V _{NO} or V _{NC} = 0.7V, 1.2V, 2V (MAX4729)	T _A = +25°C	0.05	0.15	Ω	
			T _A = -40°C to +85		0.2		
			T _A = +25°C	0.2	0.34		
			T _A = -40°C to +85		0.37		
On-Resistance Flatness (Note 4)	R _{FLAT(ON)}	V+ = 2.7V, I _{COM} = 10mA, V _{NO} or V _{NC} = 0.7V, 1.2V, 2V (MAX4729)	T _A = +25°C	0.8	1.5	Ω	
			T _A = -40°C to +85		2.2		
			T _A = +25°C	0.45	0.95		
			T _A = -40°C to +85		1.3		
NO, NC Off-Leakage Current	I _{NO (OFF)} , I _{NC (OFF)}	V+ = 3.3V, V _{COM} = 1V, 3V, V _{NO} or V _{NC} = 3V, 1V	T _A = +25°C	-2	+0.01	+2	nA
			T _A = -40°C to +85	-3		+3	
COM On-Leakage Current	I _{COM (ON)}	V+ = 3.3V, V _{COM} = 1V or 3V, V _{NO} or V _{NC} = 1V, 3V, or float	T _A = +25°C	-3	+0.01	+3	nA
			T _A = -40°C to +85	-4		+4	
DIGITAL INPUTS							
Input Logic High	V _{IH}		T _A = -40°C to +85	2.0			V
Input Logic Low	V _{IL}		T _A = -40°C to +85			0.4	V
Input Leakage Current	I _{IN}	V _{IN} = 0V or 3.6V	T _A = -40°C to +85	-1	+0.005	+1	μA

MAX4729/MAX4730

Low-Voltage 3.5Ω, SPDT, CMOS Analog Switches

ELECTRICAL CHARACTERISTICS (continued)

(V+ = +2.7V to +3.6V, V_{IH} = +2.0V, V_{IL} = +0.4V, T_A = -40°C to +85°C, unless otherwise noted. Typical values are at T_A = +25°C.) (Note 2)

PARAMETER	SYMBOL	CONDITIONS	T _A	MIN	TYP	MAX	UNITS
DYNAMIC							
Turn-On Time (Note 5)	t _{ON}	V _{NO} , V _{NC} = 2V, R _L = 300Ω, C _L = 35pF, Figure 1	T _A = +25°C	18	45		ns
			T _A = -40°C to +85		45		
Turn-Off Time (Note 5)	t _{OFF}	V _{NO} , V _{NC} = 2V, R _L = 300Ω, C _L = 35pF, Figure 1	T _A = +25°C	10	26		ns
			T _A = -40°C to +85		26		
Break-Before-Make (Note 5)		V _{NO} , V _{NC} = 2V, R _L = 300Ω, C _L = 35pF, Figure 1	T _A = +25°C	5			ns
			T _A = -40°C to +85	1			
Charge Injection	Q	V _{GEN} = 0V, R _{GEN} = 0, C _L = 1.0nF, Figure 3		3			pC
NO, NC Off-Capacitance	C _{NO(OFF)} , C _{NC(OFF)}	f = 1MHz, Figure 4		6.5			pF
Switch On-Capacitance	C _{ON}	f = 1MHz, Figure 4		19.5			pF
Off-Isolation (Note 7)	V _{ISO}	V _{NO} = V _{NC} = 1V _{RMS} , R _L = 50Ω, C _L = 5pF, Figure 2	f = 1MHz	-67			dB
			f = 10MHz	-45			
On-Channel Bandwidth -3dB	BW	Signal = 0dBm, 50Ω in and out, Figure 2		300			MHz
Crosstalk (Note 8)	V _{CT}	NO or NC = 1V _{RMS} , C _L = 5pF, R _L = 50Ω, Figure 2	f = 1MHz	-67			dB
			f = 10MHz	-52			
Total Harmonic Distortion	THD	R _L = 600Ω, V _{NC} or V _{NO} = 2V _{P-P} , f = 20Hz to 20kHz	+25°C	0.035			%
POWER SUPPLY							
Power-Supply Range	V+			1.8		5.5	V
Positive Supply Current	I+	V+ = 5.5V, V _{IN} = 0V or 5.5V	T _A = +25°C	0.001			μA
			T _A = -40°C to +85		1		

Note 2: SC70 and μDFN parts are 100% tested at T_A = +25°C. Limits across the full-temperature range are guaranteed by design and correlation.

Note 3: ΔR_{ON} = R_{ON(MAX)} - R_{ON(MIN)}.

Note 4: R_{ON} flatness is defined as the difference between the maximum and minimum value of on-resistance as measured over the specified analog signal ranges.

Note 5: Guaranteed by design.

Note 6: μDFN is guaranteed by design.

Note 7: Off-Isolation = 20log₁₀ (V_O / V_I), where V_O is V_{COM} and V_I is either V_{NC} or V_{NO} from the network analyzer.

Note 8: Crosstalk is measured between the two switches.

MAX4729/MAX4730

Low-Voltage 3.5Ω, SPDT, CMOS Analog Switches

Typical Operating Characteristics

($T_A = +25^\circ\text{C}$, unless otherwise noted.)

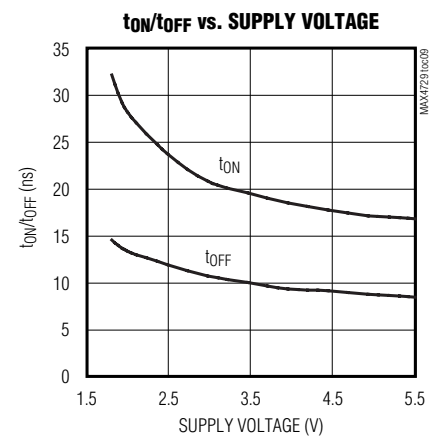
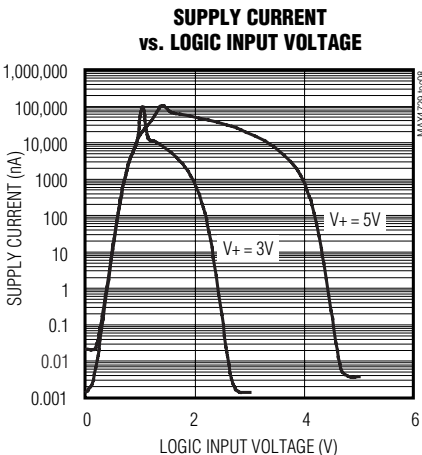
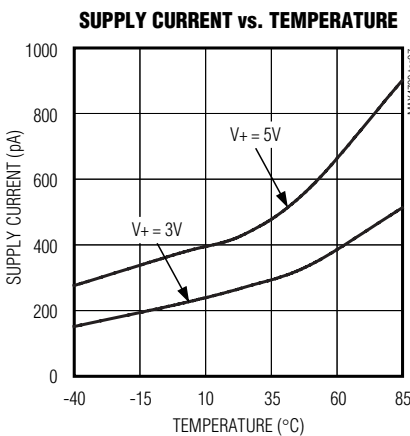
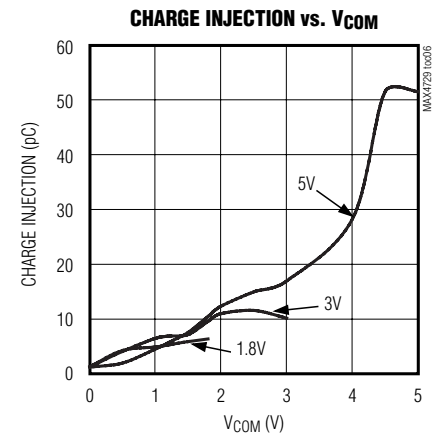
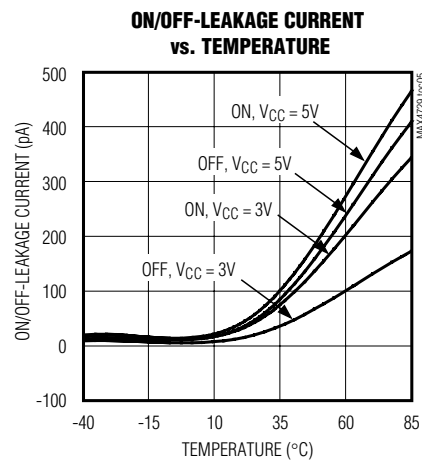
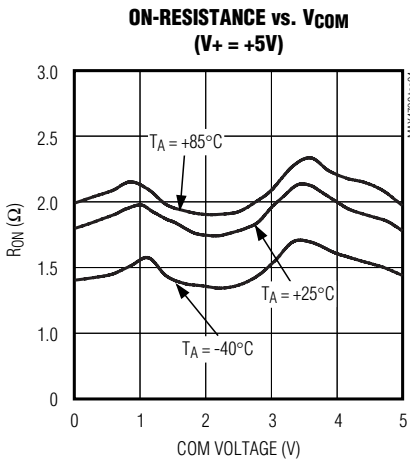
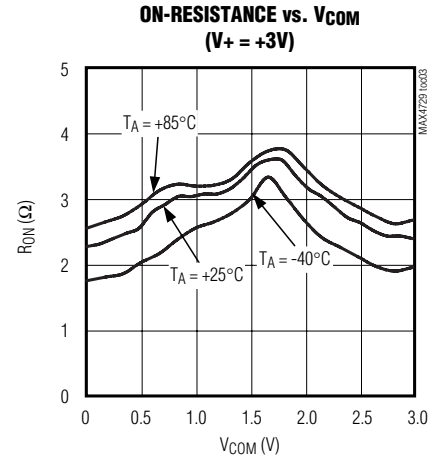
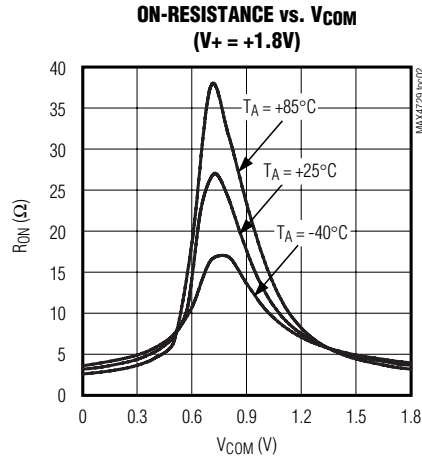
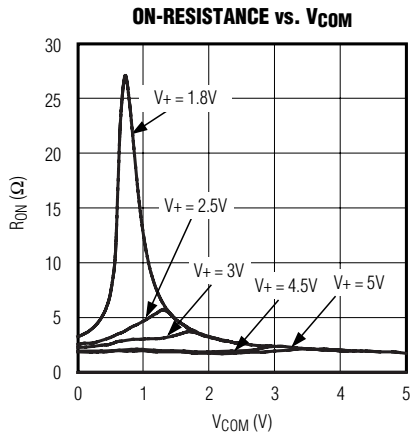

MAX4729/MAX4730

Low-Voltage 3.5Ω, SPDT, CMOS Analog Switches

Typical Operating Characteristics (continued)

(T_A = +25°C, unless otherwise noted.)

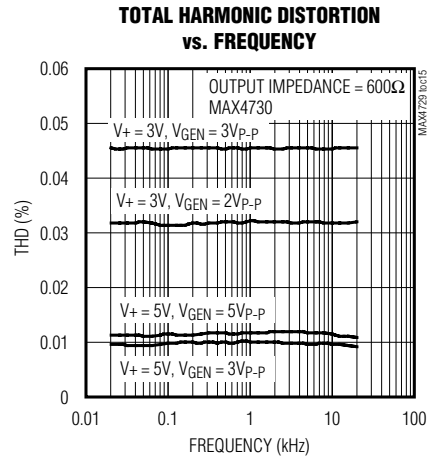
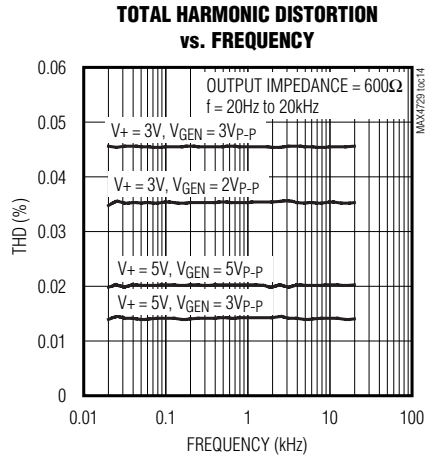
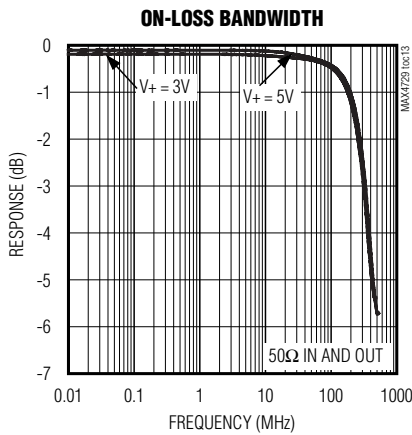
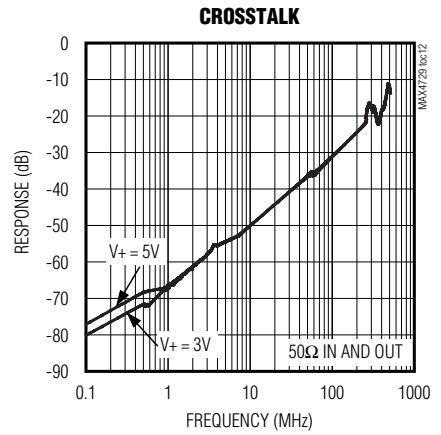
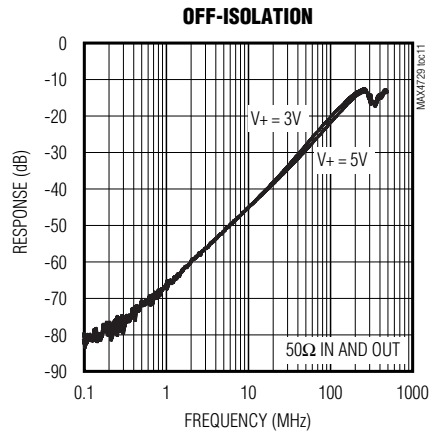
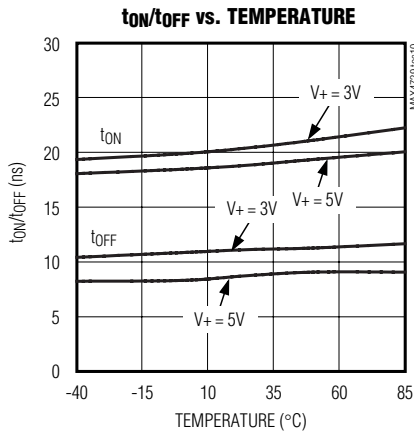

Pin Description

PIN			NAME	FUNCTION
MAX4729	MAX4730			
SC70	μDFN	SC70/μDFN		
1	3	6	IN	Logic-Control Input
2	2	5	V+	Positive Supply Voltage
3	4	2	GND	Ground
4	6	3	NC	Analogue Switch Normally Closed Terminal
5	5	4	COM	Analogue Switch Common Terminal
6	1	1	NO	Analogue Switch Normally Open Terminal

MAX4729/MAX4730

Low-Voltage 3.5Ω, SPDT, CMOS Analog Switches

Detailed Description

The MAX4729/MAX4730 single-pole/double-throw (SPDT) switches operate from a single supply ranging from +1.8V to +5.5V. These switches provide low 3.5Ω on-resistance (RON), as well as 0.45Ω RON flatness with a 2.7V supply. These devices typically consume only 1nA of supply current, making them suitable for use in low-power, portable applications. The MAX4729/MAX4730 feature low-leakage currents over the entire temperature range, TTL/CMOS-compatible digital logic, and excellent AC characteristics.

Applications Information

Digital Control Inputs

The MAX4729/MAX4730 logic inputs accept up to +5.5V, regardless of supply voltage. For example, with a +3.3V

supply, IN can be driven low to GND and high to +5.5V, allowing for mixing of logic levels in a system. With a 2.7V to 3.6V power-supply voltage range, the logic thresholds are set so $V_{IL} = 0.4V$ (max) and $V_{IH} = 2V$ (min).

Power-Supply Sequencing and Overvoltage Protection

Caution: Do not exceed the absolute maximum ratings because stresses beyond the listed ratings can cause permanent damage to the device. Proper power-supply sequencing is recommended for all CMOS devices. Always apply V_+ before applying analog signals, especially if the analog signal is not current limited.

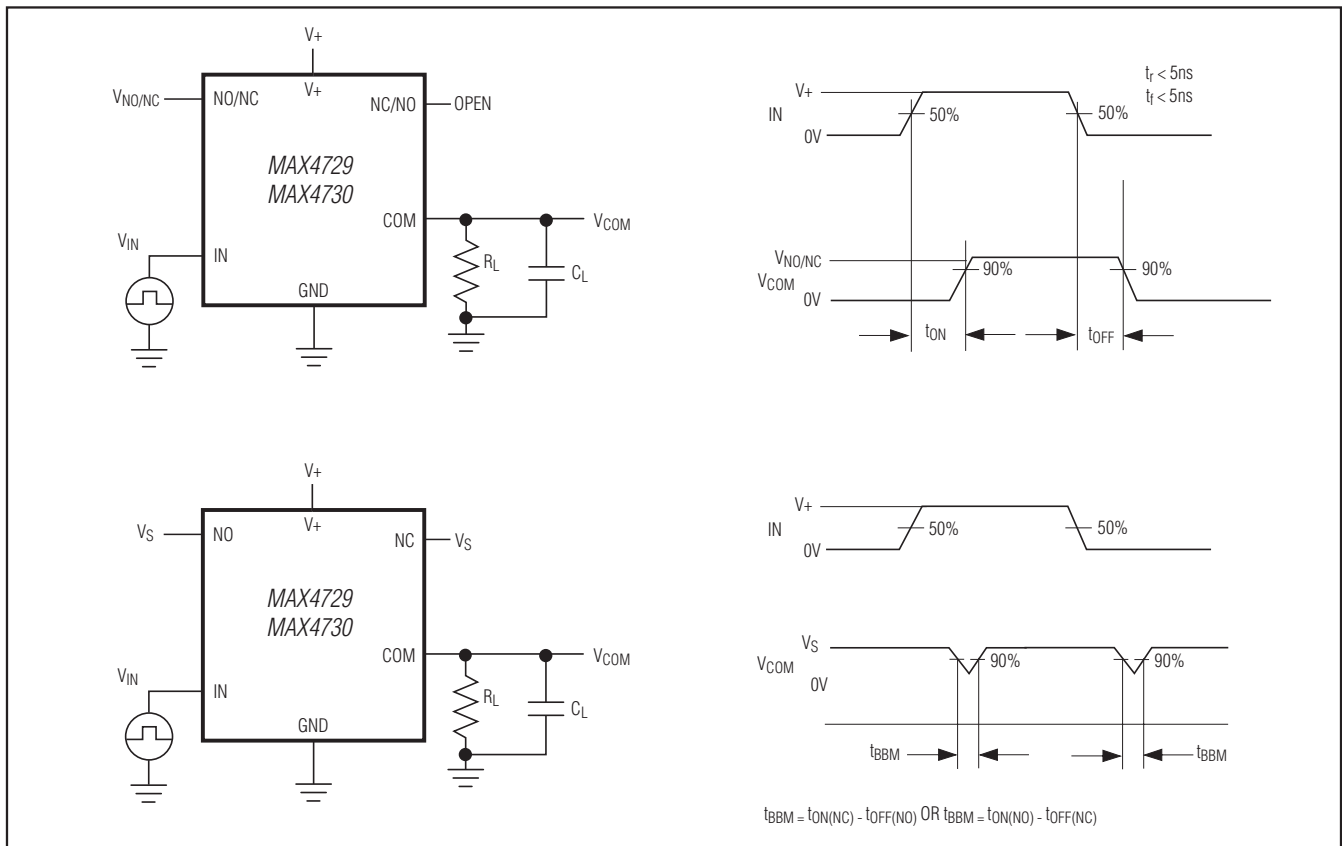

Figure 1. Switching Times

MAX4729/MAX4730

Low-Voltage 3.5Ω, SPDT, CMOS Analog Switches

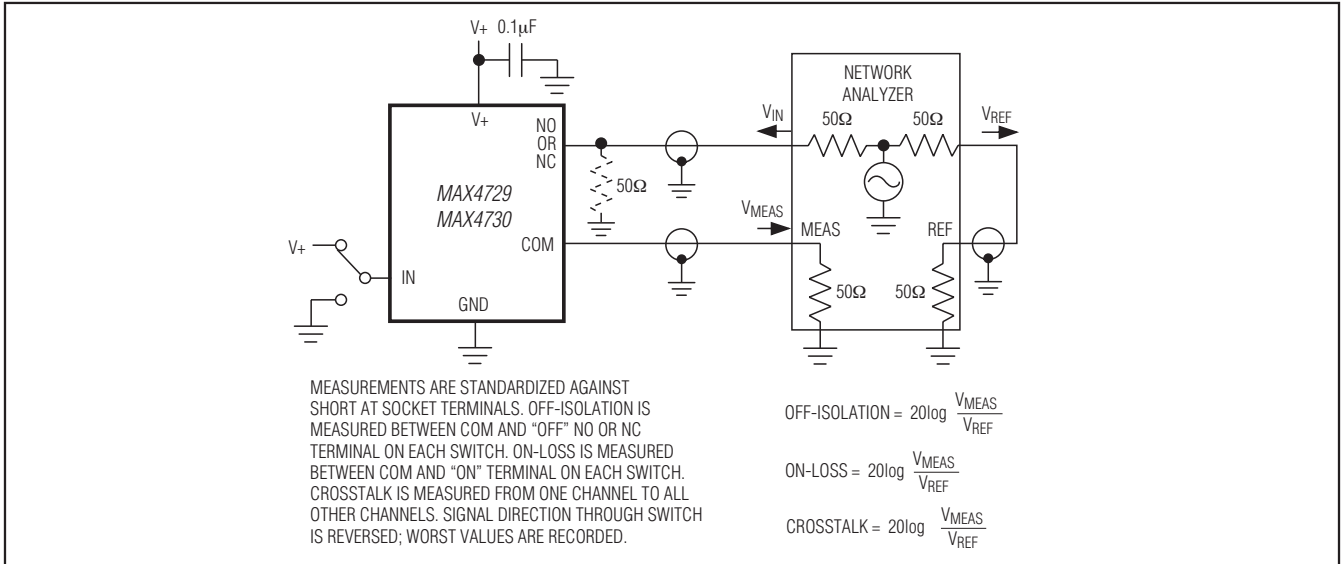

Figure 2. Off-Isolation/On-Loss Bandwidth, Crosstalk

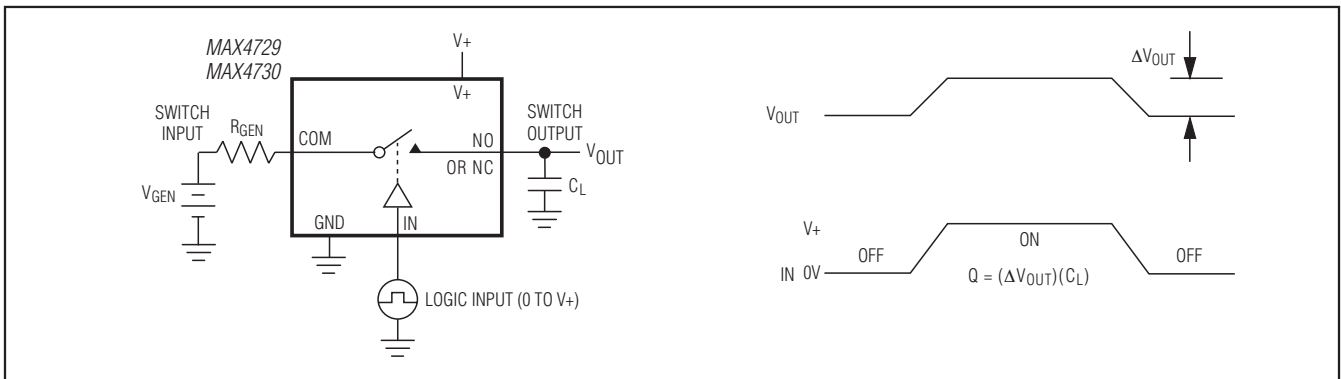

Figure 3. Charge Injection

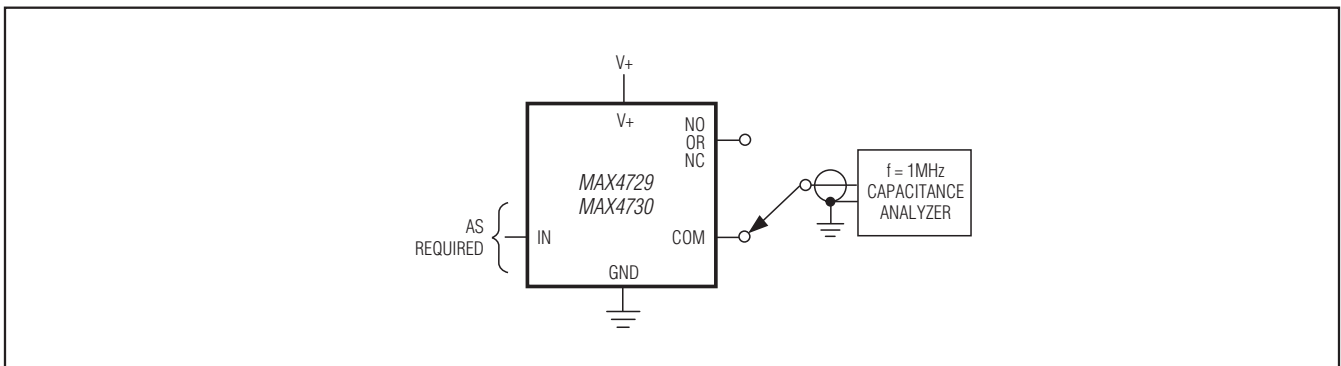

Figure 4. NO, NC, and COM Capacitance

MAX4729/MAX4730

Low-Voltage 3.5Ω, SPDT, CMOS Analog Switches

Chip Information

PROCESS: CMOS

Ordering Information

PART	TEMP RANGE	PIN-PACKAGE
MAX4729EXT+T	-40°C to +85°C	6 SC70
MAX4729ELT+T	-40°C to +85°C	6 μDFN
MAX4730EXT+T	-40°C to +85°C	6 SC70
MAX4730ELT+T	-40°C to +85°C	6 μDFN

+Denotes lead(Pb)-free/RoHS-compliant package.

Package Information

For the latest package outline information and land patterns (footprints), go to www.maximintegrated.com/packages. Note that a "+", "#", or "-" in the package code indicates RoHS status only. Package drawings may show a different suffix character, but the drawing pertains to the package regardless of RoHS status.

PACKAGE TYPE	PACKAGE CODE	OUTLINE NO.	LAND PATTERN NO.
6 SC70	X6SN+1	21-0077	90-0189
6 μDFN	L611+1	21-0147	90-0080

MAX4729/MAX4730

Low-Voltage 3.5Ω, SPDT, CMOS Analog Switches

Revision History

REVISION NUMBER	REVISION DATE	DESCRIPTION	PAGES CHANGED
2	6/14	ELT+ production status corrected	—



Maxim Integrated cannot assume responsibility for use of any circuitry other than circuitry entirely embodied in a Maxim Integrated product. No circuit patent licenses are implied. Maxim Integrated reserves the right to change the circuitry and specifications without notice at any time. The parametric values (min and max limits) shown in the Electrical Characteristics table are guaranteed. Other parametric values quoted in this data sheet are provided for guidance.

Maxim Integrated 160 Rio Robles, San Jose, CA 95134 USA 1-408-601-1000

9