



Chipsmall Limited consists of a professional team with an average of over 10 year of expertise in the distribution of electronic components. Based in Hongkong, we have already established firm and mutual-benefit business relationships with customers from,Europe,America and south Asia,supplying obsolete and hard-to-find components to meet their specific needs.

With the principle of “Quality Parts,Customers Priority,Honest Operation,and Considerate Service”,our business mainly focus on the distribution of electronic components. Line cards we deal with include Microchip,ALPS,ROHM,Xilinx,Pulse,ON,Everlight and Freescale. Main products comprise IC,Modules,Potentiometer,IC Socket,Relay,Connector.Our parts cover such applications as commercial,industrial, and automotives areas.

We are looking forward to setting up business relationship with you and hope to provide you with the best service and solution. Let us make a better world for our industry!



## Contact us

Tel: +86-755-8981 8866 Fax: +86-755-8427 6832

Email & Skype: info@chipsmall.com Web: www.chipsmall.com

Address: A1208, Overseas Decoration Building, #122 Zhenhua RD., Futian, Shenzhen, China





# HDMI 2:1 Low-Frequency Translating Switch

MAX4929E

## General Description

The MAX4929E low-frequency 2:1 switch is ideal for HDMI™/DVI™ switching applications. The device features a voltage clamp function to protect low-voltage systems at the output. The MAX4929E operates with a single 5V supply or dual or triple supplies. The MAX4929E provides clamping and voltage translation without additional components. All external inputs/outputs are electrostatic-discharge (ESD)-protected to ±6kV Human Body Model (HBM).

The MAX4929E is available in 20-pin QSOP and 20-pin, 4mm x 4mm, TQFN packages. The device is specified for the extended -40°C to +85°C operating temperature range.

## Applications

- HD Television Receivers
- HD Monitors
- High-Resolution Computer Monitors

HDMI is a trademark of HDMI Licensing, LLC.  
DVI is a trademark of Digital Display Working Group (DDWG).

## Typical Operating Circuit

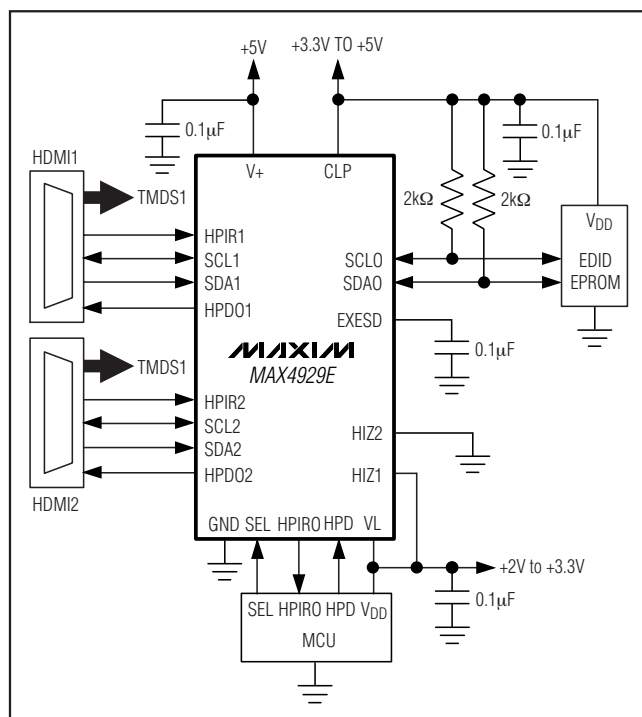

## Features

- ◆ DDC Switches
  - Low 20pF (typ) Capacitance
- ◆ Protects EDID (Extended Display Identification Data) EPROM or MCU from Excess Voltage
- ◆ Hot-Plug Detect Signal
  - Translates MCU Voltage to TTL Levels
- ◆ Two Devices Can Be Used to Form a 4:1 Switch
  - No Added Active Components Needed
- ◆ ±6kV ESD Protection HBM on All External I/Os
- ◆ Available in Lead-Free, 20-Pin TQFN or 20-Pin QSOP Packages

## Ordering Information

PART	TEMP RANGE	PIN-PACKAGE	PKG CODE
MAX4929EEEP+	-40°C to +85°C	20 QSOP	E20-1
MAX4929EETP+	-40°C to +85°C	20 TQFN-EP*	T2044-3

+ Denotes a lead-free package

\*EP = Exposed paddle.

## Pin Configurations

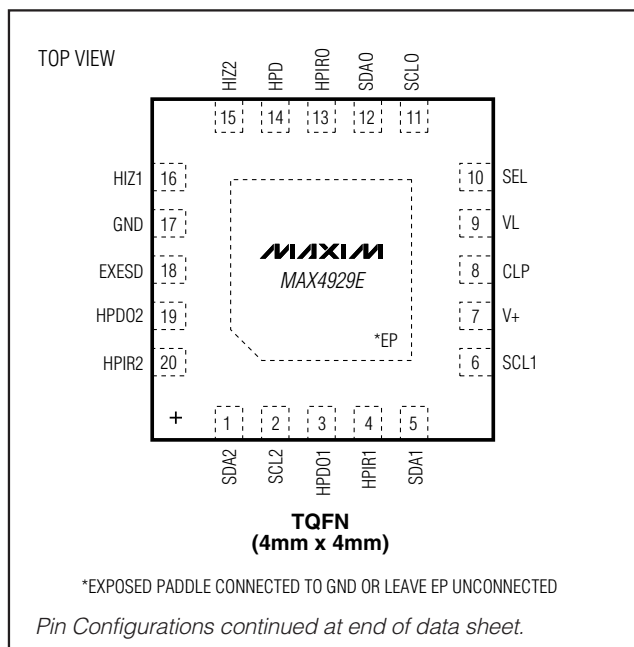

# HDMI 2:1 Low-Frequency Translating Switch

## ABSOLUTE MAXIMUM RATINGS

(All voltages referenced to GND, unless otherwise noted.)

V+	-0.3V to +6V
All Pins (except GND)	-0.3V to +6V
Continuous Current into Any I/O Terminal	25mA
Continuous Power Dissipation (T <sub>A</sub> = +70°C)	
20-Pin QSOP (derate 9.1mW/°C above +70°C)	727mW
20-Pin TQFN (derate 16.9mW/°C above +70°C)	1356mW

Operating Temperature Range	-40°C to +85°C
Storage Temperature Range	-65°C to +150°C
Junction Temperature	+150°C
Lead Temperature (soldering, 10s)	+300°C

Stresses beyond those listed under "Absolute Maximum Ratings" may cause permanent damage to the device. These are stress ratings only, and functional operation of the device at these or any other conditions beyond those indicated in the operational sections of the specifications is not implied. Exposure to absolute maximum rating conditions for extended periods may affect device reliability.

## ELECTRICAL CHARACTERISTICS

(V+ = +5V ±10%, CLP = VL = +3.3V ±10%, T<sub>A</sub> = T<sub>MIN</sub> to T<sub>MAX</sub>, unless otherwise noted. Typical values are at T<sub>A</sub> = +25°C.)

PARAMETER	SYMBOL	CONDITIONS	MIN	TYP	MAX	UNITS
<b>POWER SUPPLY</b>						
V+ Supply Current	I+	V+ = 5.5V, VL = CLP = 3.6V		3	8	μA
V+ Supply Current	I+	V+ = 0V, VL = CLP = 0V, V <sub>HPIR1</sub> = +5.5V			200	μA
VL Supply Current	I <sub>VL</sub>	V+ = 5.5V, VL = CLP = 3.6V			1	μA
CLP Supply Current	I <sub>CLP</sub>	V+ = 5.5V, VL = CLP = 3.6V			1	μA
<b>ANALOG SWITCH</b>						
On-Resistance	R <sub>ON(SCL_)</sub> , R <sub>ON(SDA_)</sub>	V+ = 4.5V, CLP = 3V, V <sub>SCL_</sub> or V <sub>SDA_</sub> = 0 to 1.5V; I <sub>SCL_</sub> or I <sub>SDA_</sub> = ±10mA		10	25	Ω
On-Resistance Match Between Channels	ΔR <sub>ON</sub>	V+ = 4.5V, CLP = 3V, V <sub>SCL_</sub> or V <sub>SDA_</sub> = 0 to 1.5V; I <sub>SCL_</sub> or I <sub>SDA_</sub> = ±10mA		2	8	Ω
On-Resistance Flatness	R <sub>FLAT</sub>	V+ = 4.5V, CLP = 3V, V <sub>SCL_</sub> or V <sub>SDA_</sub> = 0 to 1.5V; I <sub>SCL_</sub> or I <sub>SDA_</sub> = ±10mA			13	Ω
Off-Leakage Current	I <sub>SCL_(OFF)</sub> , I <sub>SDA_(OFF)</sub>	V+ = 5.5V, V <sub>SCL_</sub> or V <sub>SDA_</sub> = 0V, 5.5V; HIZ1 = HIZ2 = 0V or VL (Note 1)	-5		+5	μA
On-Leakage Current	I <sub>SCL_(ON)</sub> , I <sub>SDA_(ON)</sub>	V+ = 5.5V, V <sub>SCL_</sub> or V <sub>SDA_</sub> = 0V, 5.5V (Note 1)	-5		+5	μA
Output Clamped Voltage	V <sub>OVC(SCL_)</sub> , V <sub>OVC(SDA_)</sub>	V+ = 5V, CLP = 3.3V, VL = 5V, R <sub>P</sub> = 1kΩ (Note 2)		3.3		V
<b>SWITCH DYNAMIC CHARACTERISTICS</b>						
SCL_, SDA_ Off-Capacitance	C <sub>SCL_(OFF)</sub> , C <sub>SDA_(OFF)</sub>	V+ = 5V, T <sub>A</sub> = +25°C, Figure 1		20		pF
SCL_, SDA_ On-Capacitance	C <sub>SCL_(ON)</sub> , C <sub>SDA_(ON)</sub>	V+ = 5V, T <sub>A</sub> = +25°C, Figure 1		30		pF
Bandwidth	BW	R <sub>S</sub> = R <sub>L</sub> = 50Ω, C <sub>L</sub> = 10pF		40		MHz
Crosstalk	V <sub>CT</sub>	R <sub>S</sub> = R <sub>L</sub> = 50Ω, f = 1MHz, Figure 2 (Note 3)		-75		dB
Off-Isolation	V <sub>ISO</sub>	R <sub>S</sub> = R <sub>L</sub> = 50Ω, f = 1MHz, Figure 2 (Note 4)		-70		dB
<b>LOGIC INPUT (HPIR1, HPIR2)</b>						
Input Logic-Low Voltage	V <sub>IL</sub>	V+ = 4.5V			0.8	V
Input Logic-High Voltage	V <sub>IH</sub>	V+ = 5.5V	3.8			V
Input Logic Leakage	I <sub>INL</sub>			0.01	1	μA



# HDMI 2:1 Low-Frequency Translating Switch

MAX4929E

## ELECTRICAL CHARACTERISTICS (continued)

(V+ = +5V ±10%, CLP = VL = +3.3V ±10%, TA = TMIN to TMAX, unless otherwise noted. Typical values are at TA = +25°C.)

PARAMETER	SYMBOL	CONDITIONS	MIN	TYP	MAX	UNITS
<b>LOGIC INPUT (SEL, HPD, HIZ1, HIZ2)</b>						
Input Logic-Low Voltage	V <sub>IL</sub>	V+ = 4.5V, VL = CLP = 3V			0.8	V
Input Logic-High Voltage	V <sub>IH</sub>	V+ = 5.5V, VL = CLP = 3.6V	2.0			V
Hysteresis	V <sub>HYST</sub>	3V ≤ VL = CLP ≤ 3.6V		150		mV
Input Logic-Leakage Current	I <sub>INL</sub>			0.01	1	μA
<b>LOGIC OUTPUT (HPDO1, HPDO2, HPIRO)</b>						
HPDO_ Output Logic-Low Voltage	V <sub>OL</sub> (HPDO_)	V+ = 4.5V, VL = CLP = 3.0V, I <sub>SINK</sub> = 4mA			0.5	V
HPDO_ Output Logic-High Voltage	V <sub>OH</sub> (HPDO_)	V+ = 4.5V, VL = CLP = 3.0V, I <sub>SOURCE</sub> = 4mA	4.0			V
HPIRO Output Logic-Low Voltage	V <sub>OL</sub> (HPIRO)	V+ = 4.5V, VL = CLP = 3.0V, I <sub>SINK</sub> = 2mA			0.5	V
HPIRO Output Logic-High Voltage	V <sub>OH</sub> (HPIRO)	V+ = 4.5V, VL = CLP = 3.0V, I <sub>SOURCE</sub> = 2mA	2.5			V
Output-Logic Leakage Current	I <sub>O</sub>	HIZ1 = HIZ2 = 0V or VL			1	μA
<b>TIMING CHARACTERISTICS</b>						
Logic Delay	t <sub>PD</sub> (HPDO_)	V+ = 4.5V, VL = CLP = 3.0V, C <sub>L</sub> = 15pF, SEL = 0V or VL (Figure 3)		33		ns
	t <sub>PD</sub> (HPIRO)	V+ = 4.5V, VL = CLP = 3.0V, C <sub>L</sub> = 15pF, SEL = 0V or VL (Figure 3)		33		
<b>ESD PROTECTION</b>						
ESD Protection, Human Body Model		HPIR1, HPIR2, HPDO1, HPDO2, SCL1, SCL2, SDA1, SDA2 (Note 5)		±6		kV
		HPIRO, HPD, SEL, SCLO, SDAO, HIZ1, HIZ2 (Note 6)		±2		
EXESD Leakage Current				1.0		μA

**Note 1:** Leakage measured at SCLO or SDAO with SCL\_ and SDA\_ open.

**Note 2:** Pullup resistor of R<sub>P</sub> = 1kΩ at SCLO and SDAO. These resistors are necessary for the clamp/translation to operate correctly.

**Note 3:** Crosstalk is measured between any two analog inputs, crosstalk = 20log(V<sub>OUT</sub> / V<sub>IN</sub>).

**Note 4:** Off-isolation = 20log<sub>10</sub> (V<sub>SCLO</sub> / V<sub>SCL\_</sub>), V<sub>SCLO</sub> = output, V<sub>SCL\_</sub> = input to off switch.

**Note 5:** Referenced to GND.

**Note 6:** Any combination of pin to any other pin.

# HDMI 2:1 Low-Frequency Translating Switch

## Test Circuits/Timing Diagrams

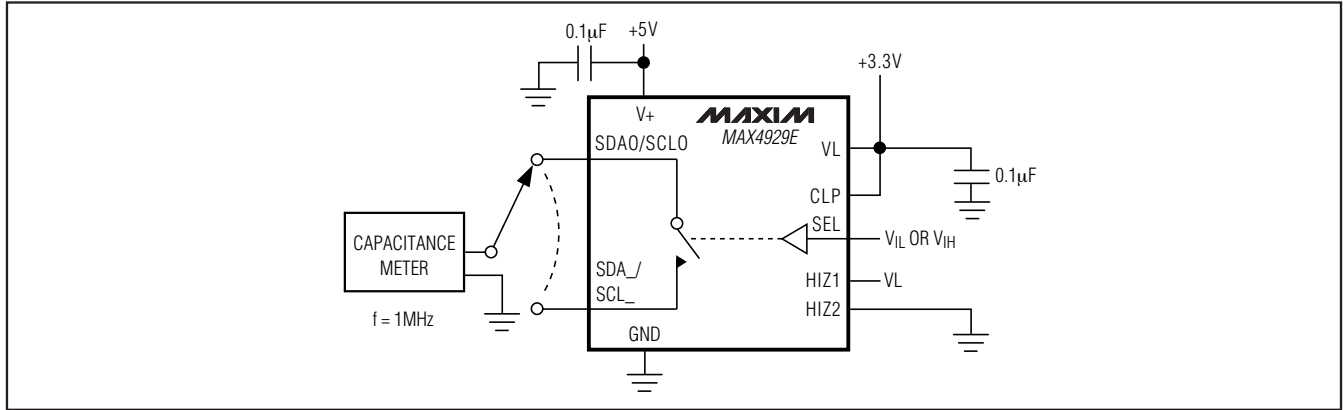

Figure 1. Channel Off-/On-Capacitance

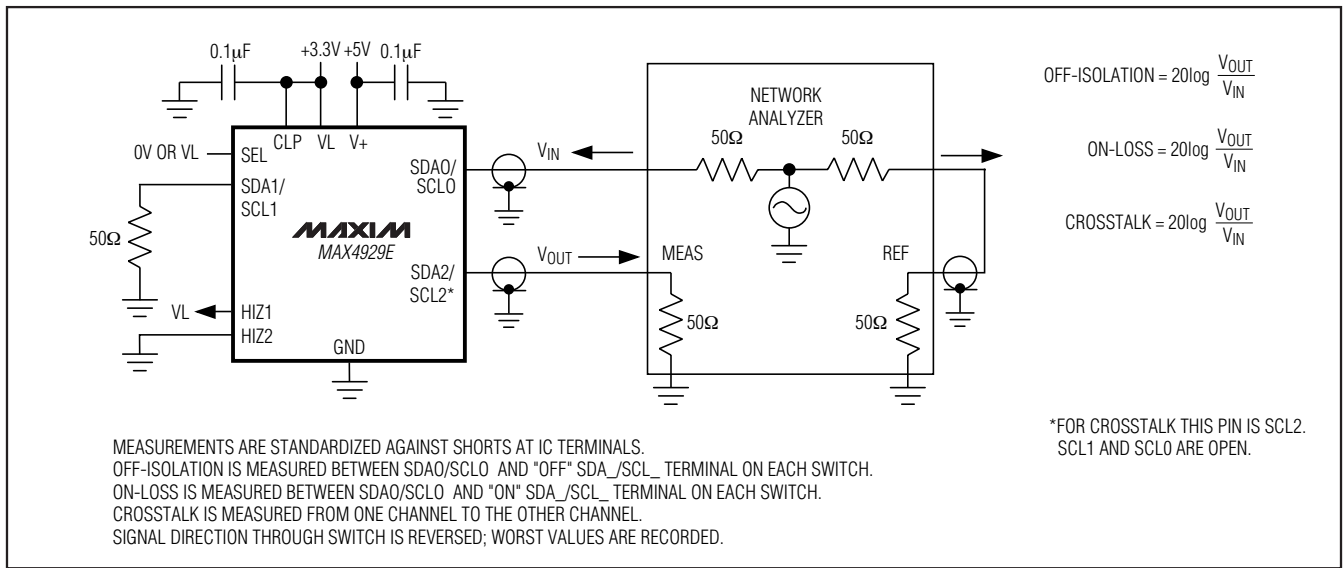

Figure 2. On-Loss, Off-Isolation, and Crosstalk

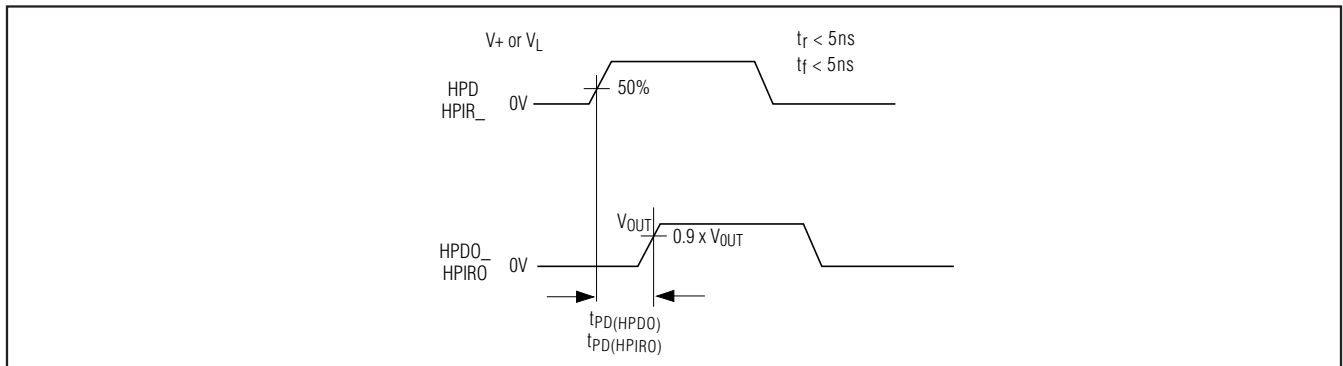

Figure 3. Logic Delay Timing

# HDMI 2:1 Low-Frequency Translating Switch

MAX4929E

## Typical Operating Characteristics

( $V_+ = 5V$ ,  $V_L = 3.3V$ ,  $CLP = 3.3V$ ,  $T_A = +25^\circ C$ , unless otherwise noted.)

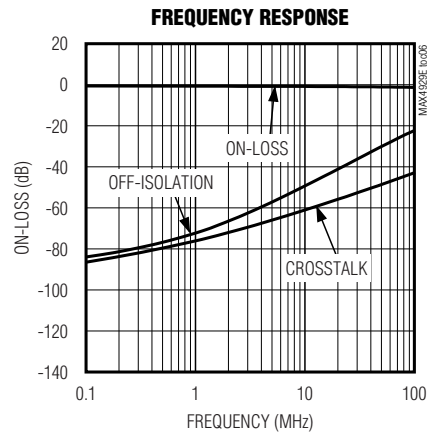
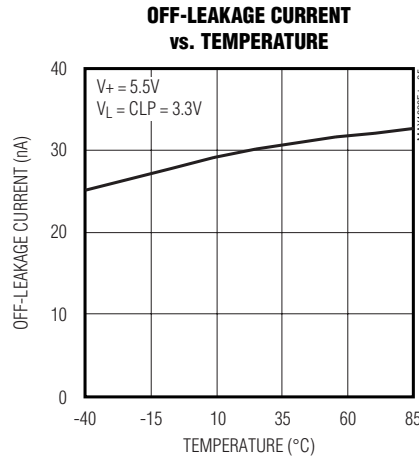
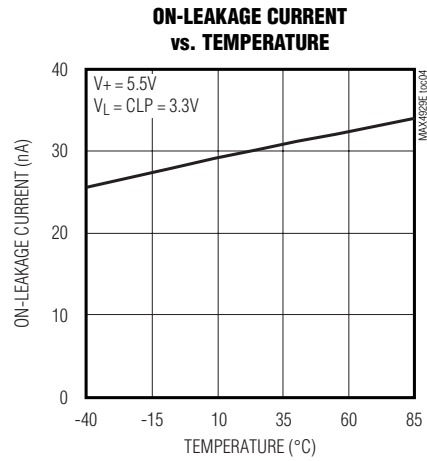
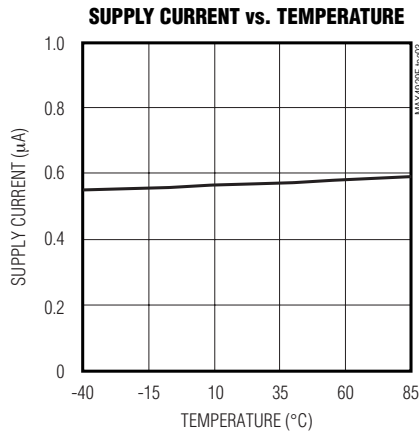
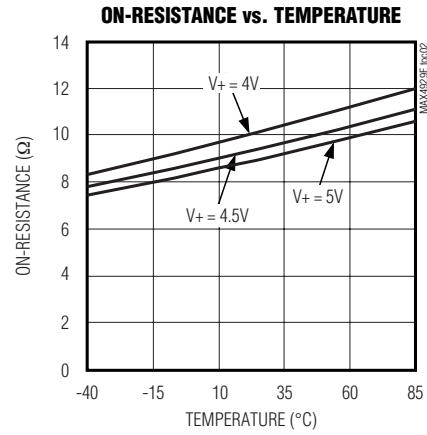
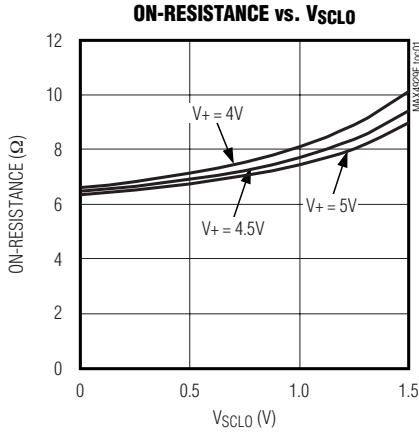

# HDMI 2:1 Low-Frequency Translating Switch

## Pin Description

PIN		NAME	FUNCTION
QSOP	TQFN		
1	19	HPDO2	Hot-Plug Detect Output 2. Translate logic level of HPD to V+ compatible (see Table 2).
2	20	HPIR2	Hot-Plug Interrupt Request 2
3	1	SDA2	Serial Data Input. SDA Mux Input 2.
4	2	SCL2	Serial Clock Input. SCL Mux Input 2.
5	3	HPDO1	Hot-Plug Detect Output 1. Translate logic level of HPD to V+ compatible (see Table 2).
6	4	HPIR1	Hot-Plug Interrupt Request 1
7	5	SDA1	Serial Data Input. SDA Mux Input 1.
8	6	SCL1	Serial Clock Input. SCL Mux Input 1.
9	7	V+	Positive Supply Voltage. Bypass V+ to GND with a 0.1 $\mu$ F or greater ceramic capacitor.
10	8	CLP	Clamp-Voltage Reference. Clamp the maximum voltage of SCLO and SDAO. Bypass CLP to GND with a 0.1 $\mu$ F or greater ceramic capacitor (see Figure 6 and the <i>Typical Operating Circuit</i> ).
11	9	VL	Logic Supply for HIZ_, SEL, HPD, HPIRO. Bypass VL to GND with a 0.1 $\mu$ F or greater ceramic capacitor. VL should have the same voltage level as any MCU interface.
12	10	SEL	Select Input. Logic input for Mux connection (see Table 1).
13	11	SCLO	SCL Mux Output. Connect SCLO to EDID EPROM.
14	12	SDAO	SDA Mux Output. Connect SDAO to EDID EPROM.
15	13	HPIRO	Hot-Plug Interrupt Request Output. Translate logic level of HPIR_ to VL compatible (see Table 3).
16	14	HPD	Hot-Plug Detect Input. Logic level on HPD is compatible with MCU.
17	15	HIZ2	Enable Input 2 (see Table 4).
18	16	HIZ1	Enable Input 1 (see Table 4).
19	17	GND	Ground
20	18	EXESD	External ESD Discharge. Connect 0.1 $\mu$ F capacitor from EXESD to GND.
—	EP	EP	Exposed Paddle. Connect EP to GND or leave EP unconnected.

# HDMI 2:1 Low-Frequency Translating Switch

## Functional Diagram

MAX4929E

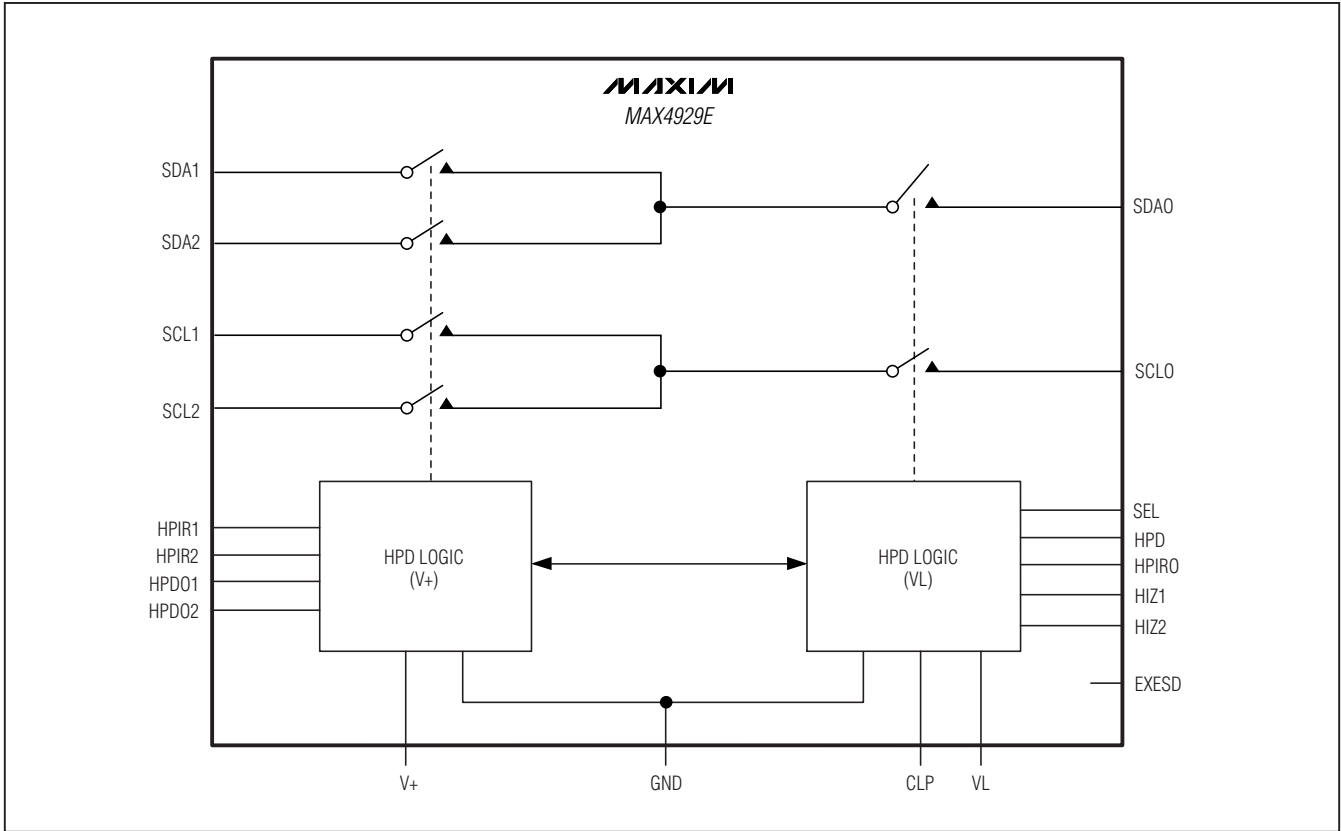

### Detailed Description

The MAX4929E low-frequency 2:1 switch is ideal for the low-frequency portion of HDMI/DVI switching applications. The device features three independent voltage inputs that allow the user to match any voltage level encountered in switching without additional components. The V+ range is from 4.5V to 5.5V to match the HDMI/DVI 5V requirements. CLP is set to match the EDID EPROM from 3.3V to 5.5V. VL is connected to the same supply as the system MCU. All pins going to the HDMI/DVI connectors are ESD-protected to  $\pm 6kV$  Human Body Model (HBM).

The MAX4929E has two enable inputs. The enable function allows the device to operate in normal mode or go into a high-Z state. It is possible to control two MAX4929Es with a single control bit, creating a 4:1 equivalent switch using a minimum of external components (see Figure 6).

Supply or signals sequencing are not required for the MAX4929E. Supply voltages V+, VL, and CLP can be

applied in any order. Signals can be applied in any order as well.

### Analog Switch

The MAX4929E features a voltage clamp function for the two 2:1 switch. Inputs to SCL\_/SDA\_ are V+ level compatible. Maximum output voltages of SCLO/SDAO are clamped to CLP. For optimum performance connect the EDID EPROM supply voltage to CLP (see Figure 6). For proper operation of the voltage clamp, connect SCLO/SDAO to CLP through the pullup resistors. For maximum output range, connect CLP to V+. The output of the switch is connected to the EDID EPROM, voltages from 3V to 5.5V are expected.

### Logic Inputs

VL is the supply to input logic HIZ\_, SEL, and HPD. Connect VL to the same supply as the system MCU for compatibility.

V+ is the supply to the input logic of the HPIR1 and HPIR2 inputs.



# HDMI 2:1 Low-Frequency Translating Switch

**Table 1. Inputs Selection for 2:1 Mux Truth Table**

INPUTS			SWITCH CONNECTIONS
SEL	HIZ1	HIZ2	
0	0	1	SDAO to SDA1, SCLO to SCL1
0	1	0	SDAO to SDA1, SCLO to SCL1
1	0	1	SDAO to SDA2, SCLO to SCL2
1	1	0	SDAO to SDA2, SCLO to SCL2
X	0	0	High Impedance
X	1	1	High Impedance

**Table 2. HPD Output Channel Selection**

INPUTS				OUTPUTS	
SEL	HPD	HIZ1	HIZ2	HPDO1	HPDO2
X	0	0	1	0	0
		1	0		
0	1	0	1	1	0
		1	0		
1	1	0	1	0	1
		1	0		
X	X	1	1	High Impedance	High Impedance
X	X	0	0	High Impedance	High Impedance

**Table 3. HPIRO Output Channel Selection**

INPUTS					OUTPUT
SEL	HPIR1	HPIR2	HIZ1	HIZ2	HPIRO
X	0	0	0	1	0
			1	0	
X	1	1	0	1	1
			1	0	
0	0	X	0	1	0
			1	0	
0	1	X	0	1	1
			1	0	
1	X	0	0	1	0
			1	0	
1	X	1	0	1	1
			1	0	
X	X	X	0	0	High Impedance
X	X	X	1	1	High Impedance

**Table 4. Mode of Operation**

INPUTS		OUTPUTS
HIZ1	HIZ2	MODE OF OPERATION
0	0	High Impedance: SDA0, SDA1, SDA2, SCLO, SCL1, SCL2, HPDO1, HPDO2, HPIRO
0	1	Normal Operation
1	0	Normal Operation
1	1	High Impedance: SDA0, SDA1, SDA2, SCLO, SCL1, SCL2, HPDO1, HPDO2, HPIRO

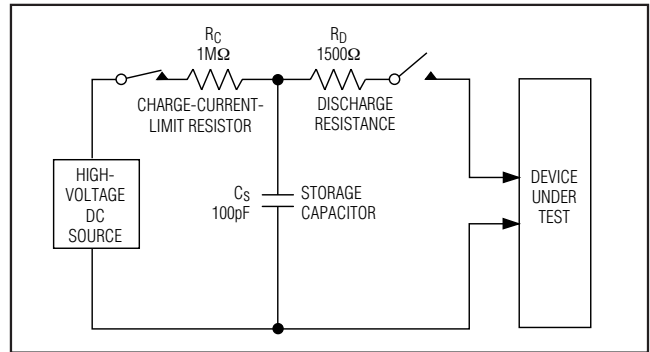

Figure 4. Human Body ESD Test Model

**Logic Outputs**

The HPDO\_ signals are 5V TTL-compatible, per HDMI/DVI specifications. HPIRO is VL compatible.

**ESD Protection**

As with all Maxim devices, ESD-protection structures are incorporated on all pins to protect against ESD encountered during handling and assembly. Additionally, the MAX4929E is protected to ±6kV (HBM) on SCL1, SCL2, SDA1, SDA2, HPDO1, HPDO2, HPIR1, and HPIR2 by the HBM.

**Human Body Model**

Several ESD testing standards exist for measuring the robustness against ESD events. The ESD protection of the MAX4929E is characterized with the HBM method. Figure 4 shows the model used to simulate an ESD event resulting from contact with the human body. The model consists of a 100pF storage capacitor that is charged to a high voltage, then discharged through a 1.5kΩ resistor. Figure 5 shows the current waveform when the storage capacitor is discharged into a lower impedance.

**ESD Test Conditions**

ESD performance depends on a variety of conditions. Contact Maxim for a reliability report documenting test setup, methodology, and results.

# HDMI 2:1 Low-Frequency Translating Switch

**MAX4929E**

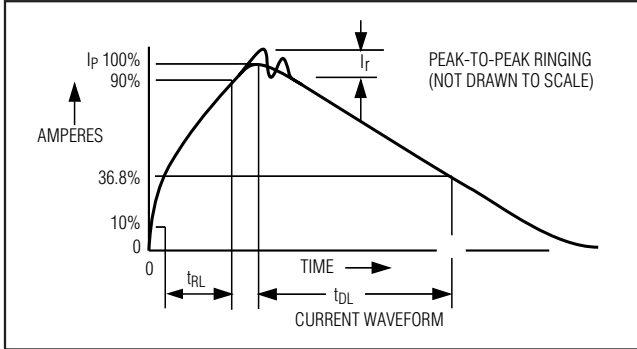

Figure 5. HBM Discharge Current Waveform

V+, VL, and CLP to GND using 0.1μF or larger ceramic capacitors as close to the device as possible.

### Hot Plug

The MAX4929E is designed for HDMI/DVI switching. The MAX4929E permits hot-plugging to any inputs/ outputs regardless of the power status of the device. A plug can be inserted, and thus connected to the MAX4929E whether the device is powered up or not. Therefore, sequencing of power supplies is not required; V+, CLP, and VL can be applied in any order.

### Configure Two Devices to Form 4:1 Switch

Two MAX4929Es can be connected together to form a 4:1 switch (see Figure 6).

## Applications Information

### Power-Supply Bypassing and Sequencing

There is no power-supply sequencing required. Power can be applied to V+, CLP, or VL in any order. Bypass

### Exposed Paddle

The MAX4929EETP+ provides an EP to improve thermal performance in the TQFN package. Connect the EP to GND or leave EP unconnected.

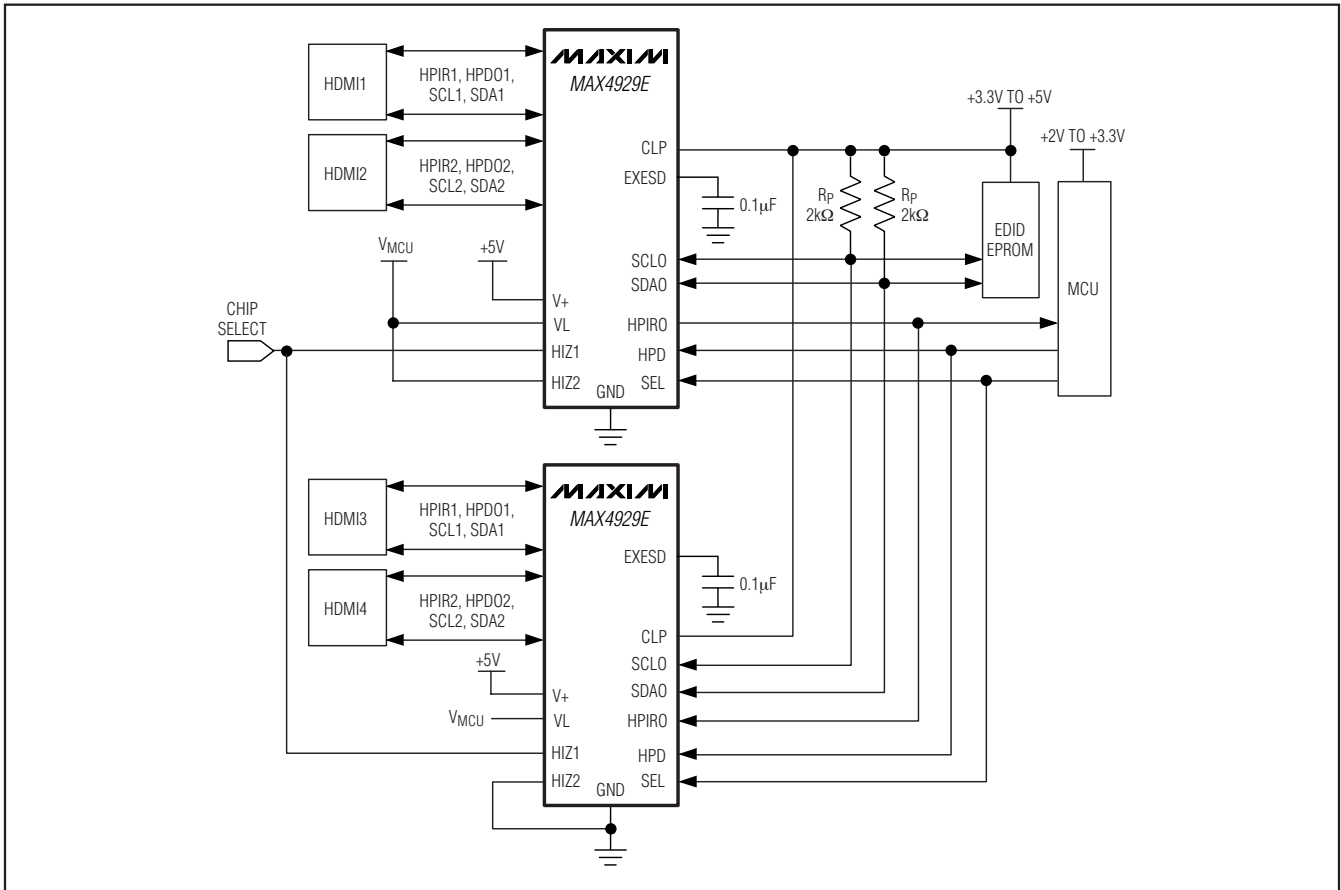

Figure 6. Two MAX4929Es Connected to Form a 4:1 Translating Switch

# HDMI 2:1 Low-Frequency Translating Switch

**MAX4929E**

## Pin Configurations (continued)

## Chip Information

PROCESS: BiCMOS

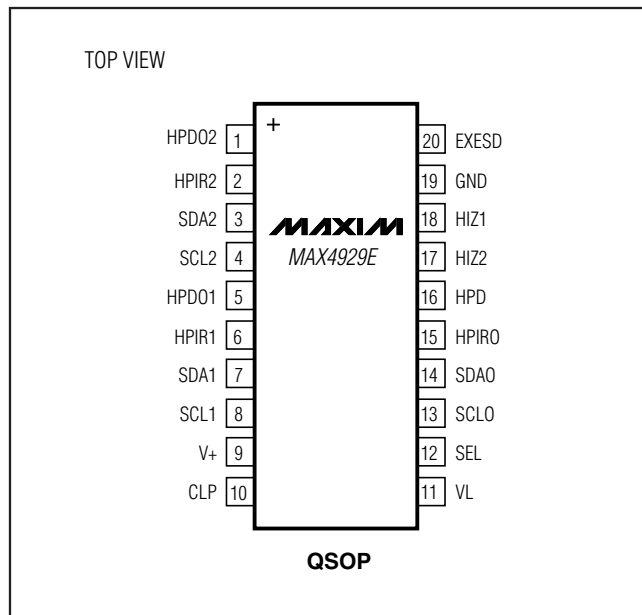

# HDMI 2:1 Low-Frequency Translating Switch

## Package Information

(The package drawing(s) in this data sheet may not reflect the most current specifications. For the latest package outline information go to [www.maxim-ic.com/packages](http://www.maxim-ic.com/packages).)

**MAX4929E**

24L QFN THINLEPS

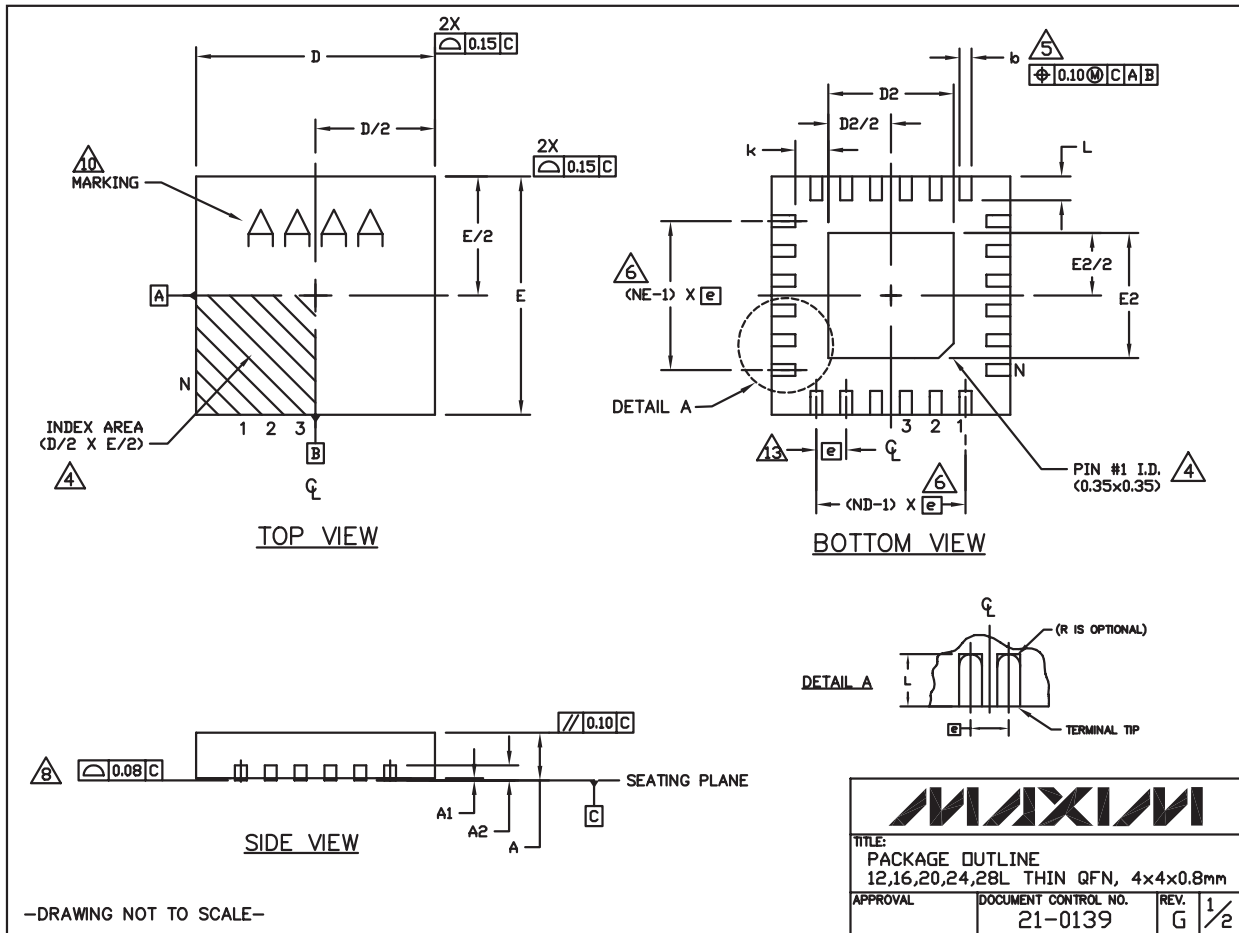

# HDMI 2:1 Low-Frequency Translating Switch

## Package Information (continued)

(The package drawing(s) in this data sheet may not reflect the most current specifications. For the latest package outline information go to [www.maxim-ic.com/packages](http://www.maxim-ic.com/packages).)

COMMON DIMENSIONS															
PKG	12L 4x4			16L 4x4			20L 4x4			24L 4x4			28L 4x4		
REF.	MIN.	NDM.	MAX.	MIN.	NDM.	MAX.	MIN.	NDM.	MAX.	MIN.	NDM.	MAX.	MIN.	NDM.	MAX.
A	0.70	0.75	0.80	0.70	0.75	0.80	0.70	0.75	0.80	0.70	0.75	0.80	0.70	0.75	0.80
A1	0.0	0.02	0.05	0.0	0.02	0.05	0.0	0.02	0.05	0.0	0.02	0.05	0.0	0.02	0.05
A2	0.20 REF			0.20 REF			0.20 REF			0.20 REF			0.20 REF		
b	0.25	0.30	0.35	0.25	0.30	0.35	0.20	0.25	0.30	0.18	0.23	0.30	0.15	0.20	0.25
D	3.90	4.00	4.10	3.90	4.00	4.10	3.90	4.00	4.10	3.90	4.00	4.10	3.90	4.00	4.10
E	3.90	4.00	4.10	3.90	4.00	4.10	3.90	4.00	4.10	3.90	4.00	4.10	3.90	4.00	4.10
e	0.80 BSC.			0.65 BSC.			0.50 BSC.			0.50 BSC.			0.40 BSC.		
k	0.25	-	-	0.25	-	-	0.25	-	-	0.25	-	-	0.25	-	-
L	0.45	0.55	0.65	0.45	0.55	0.65	0.45	0.55	0.65	0.30	0.40	0.50	0.30	0.40	0.50
N	12			16			20			24			28		
ND	3			4			5			6			7		
NE	3			4			5			6			7		
Jedec Var.	WGGB			WGGC			WGGD-1			WGGD-2			WGGE		

EXPOSED PAD VARIATIONS						
PKG. CODES	D2			E2		
	MIN.	NDM.	MAX.	MIN.	NDM.	MAX.
T1244-3	1.95	2.10	2.25	1.95	2.10	2.25
T1244-4	1.95	2.10	2.25	1.95	2.10	2.25
T1644-3	1.95	2.10	2.25	1.95	2.10	2.25
T1644-4	1.95	2.10	2.25	1.95	2.10	2.25
T2044-2	1.95	2.10	2.25	1.95	2.10	2.25
T2044-3	1.95	2.10	2.25	1.95	2.10	2.25
T2444-2	1.95	2.10	2.25	1.95	2.10	2.25
T2444-3	2.45	2.60	2.63	2.45	2.60	2.63
T2444-4	2.45	2.60	2.63	2.45	2.60	2.63
T2844-1	2.50	2.60	2.70	2.50	2.60	2.70

NOTES:

- DIMENSIONING & TOLERANCING CONFORM TO ASME Y14.5M-1994.
- ALL DIMENSIONS ARE IN MILLIMETERS. ANGLES ARE IN DEGREES.
- N IS THE TOTAL NUMBER OF TERMINALS.
- THE TERMINAL #1 IDENTIFIER AND TERMINAL NUMBERING CONVENTION SHALL CONFORM TO JESD 95-1 SPP-012. DETAILS OF TERMINAL #1 IDENTIFIER ARE OPTIONAL, BUT MUST BE LOCATED WITHIN THE ZONE INDICATED. THE TERMINAL #1 IDENTIFIER MAY BE EITHER A MOLD OR MARKED FEATURE.
- DIMENSION b APPLIES TO METALLIZED TERMINAL AND IS MEASURED BETWEEN 0.25mm AND 0.30mm FROM TERMINAL TIP.
- ND AND NE REFER TO THE NUMBER OF TERMINALS ON EACH D AND E SIDE RESPECTIVELY.
- DEPOPULATION IS POSSIBLE IN A SYMMETRICAL FASHION.
- COPLANARITY APPLIES TO THE EXPOSED HEAT SINK SLUG AS WELL AS THE TERMINALS.
- DRAWING CONFORMS TO JEDEC MO220, EXCEPT FOR T2444-3, T2444-4 AND T2844-1.
- MARKING IS FOR PACKAGE ORIENTATION REFERENCE ONLY.
- COPLANARITY SHALL NOT EXCEED 0.08mm.
- WARPAGE SHALL NOT EXCEED 0.10mm.
- LEAD CENTERLINES TO BE AT TRUE POSITION AS DEFINED BY BASIC DIMENSION 'e', ±0.05.
- NUMBER OF LEADS SHOWN ARE FOR REFERENCE ONLY.
- ALL DIMENSIONS ARE THE SAME FOR LEADED (-) & PbfREE (+) PACKAGE CODES.

-DRAWING NOT TO SCALE-

TITLE: PACKAGE OUTLINE 12,16,20,24,28L THIN QFN, 4x4x0.8mm			
APPROVAL	DOCUMENT CONTROL NO.	REV.	2/2
	21-0139	G	



# HDMI 2:1 Low-Frequency Translating Switch

## Package Information (continued)

(The package drawing(s) in this data sheet may not reflect the most current specifications. For the latest package outline information go to [www.maxim-ic.com/packages](http://www.maxim-ic.com/packages).)

MAX4929E

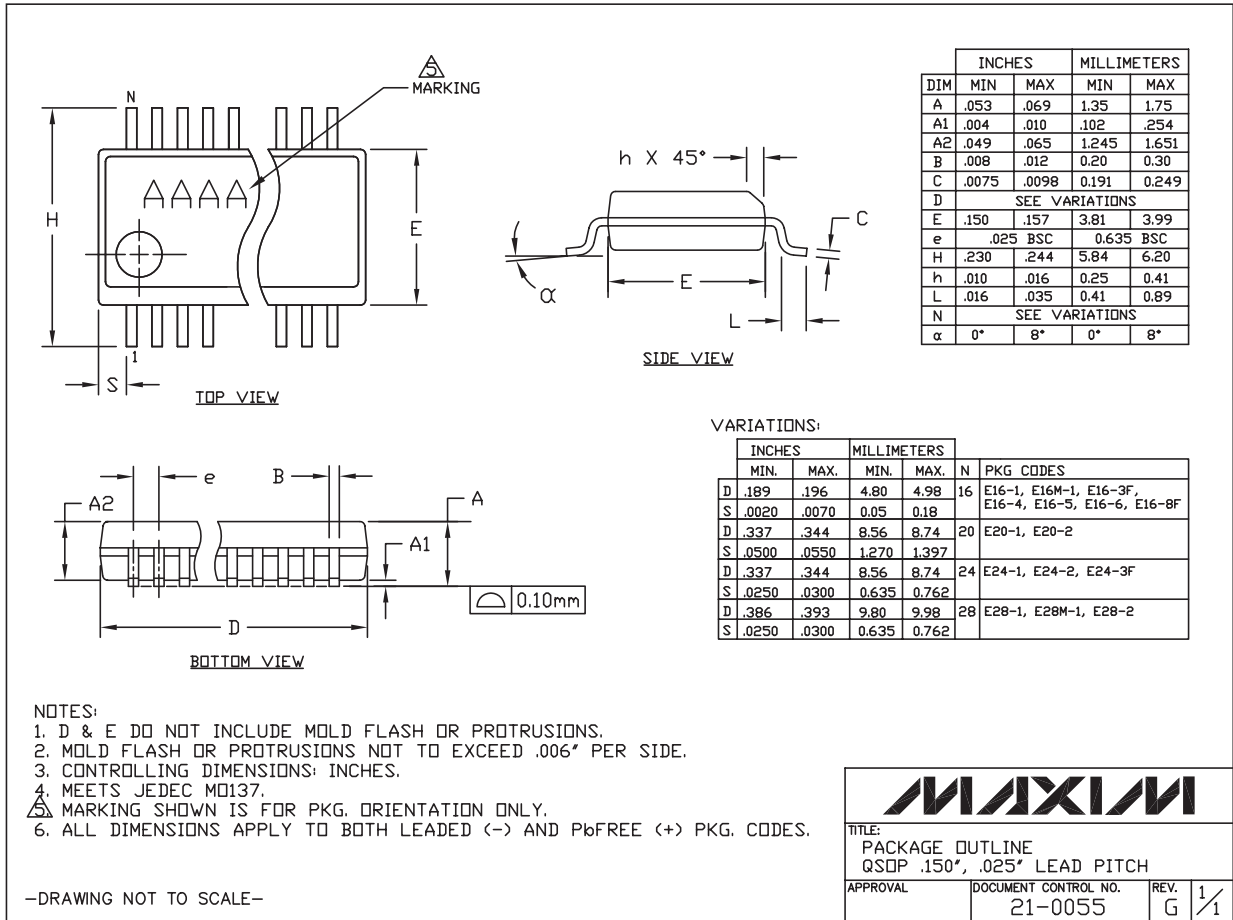

Maxim cannot assume responsibility for use of any circuitry other than circuitry entirely embodied in a Maxim product. No circuit patent licenses are implied. Maxim reserves the right to change the circuitry and specifications without notice at any time.

Maxim Integrated Products, 120 San Gabriel Drive, Sunnyvale, CA 94086 408-737-7600 13