



Chipsmall Limited consists of a professional team with an average of over 10 year of expertise in the distribution of electronic components. Based in Hongkong, we have already established firm and mutual-benefit business relationships with customers from,Europe,America and south Asia,supplying obsolete and hard-to-find components to meet their specific needs.

With the principle of “Quality Parts,Customers Priority,Honest Operation,and Considerate Service”,our business mainly focus on the distribution of electronic components. Line cards we deal with include Microchip,ALPS,ROHM,Xilinx,Pulse,ON,Everlight and Freescale. Main products comprise IC,Modules,Potentiometer,IC Socket,Relay,Connector.Our parts cover such applications as commercial,industrial, and automotives areas.

We are looking forward to setting up business relationship with you and hope to provide you with the best service and solution. Let us make a better world for our industry!



Contact us

Tel: +86-755-8981 8866 Fax: +86-755-8427 6832

Email & Skype: info@chipsmall.com Web: www.chipsmall.com

Address: A1208, Overseas Decoration Building, #122 Zhenhua RD., Futian, Shenzhen, China





Overvoltage Protector with Active Current Limit

General Description

The MAX4978–MAX4981 overvoltage-protection devices protect low-voltage systems against voltage faults up to +28V and feature a low 85mΩ R_{ON} FET, an active current limiter, and lithium-ion battery overcharge protection (MAX4980/MAX4981). These devices are used to protect the charger input port on a portable device.

The overvoltage protector feature protects against voltages up to 28V with two different trip thresholds: 5.7V (MAX4978/MAX4980/MAX4981) and 6.8V (MAX4979). There is an undervoltage protector with two different trip thresholds: 4.4V (MAX4978) and 2.63V (MAX4979/MAX4980/MAX4981).

The overcurrent limiter and battery voltage monitor features provide a second layer of protection for a lithium-ion battery charger. The overcurrent limiter is available in two different thresholds: 0.9A (MAX4978/MAX4979/MAX4980) and 1.95A (MAX4981). Once current reaches the threshold, it is held for a 20ms blanking time. If the current is still at the limit after the blanking time, the FET is turned off, and the device restarts the cycle after 160ms. The battery voltage monitor measures the voltage of a lithium-ion battery and disables the FET if the battery voltage reaches 4.4V (MAX4980/MAX4981).

The MAX4978–MAX4981 are available in a small 8-pin TDFN (2mm x 3mm) package and are specified over the extended -40°C to +85°C temperature range.

Applications

Cell Phones	PDA's and Palmtop Devices
MP3 Players	
Digital Still Cameras	

Typical Application Circuit appears at end of data sheet.

Features

- ◆ Input Voltage Protection Up to +28V
- ◆ Integrated nFET Switch, 85mΩ (typ)
- ◆ Preset Overvoltage Protection Trip Level
5.7V (typ) (MAX4978/MAX4980/MAX4981)
6.8V (typ) (MAX4979)
- ◆ Low-Current Undervoltage Lockout Mode
- ◆ Overcurrent Protection
- ◆ Internal 160ms (typ) Startup Delay
- ◆ Thermal-Shutdown Protection
- ◆ Battery Overcharge Protection (MAX4980/MAX4981)
- ◆ Startup Debounce Time Indicator (MAX4978/MAX4979)
- ◆ Small, 8-Pin (2mm x 3mm) TDFN Package

Pin Configuration

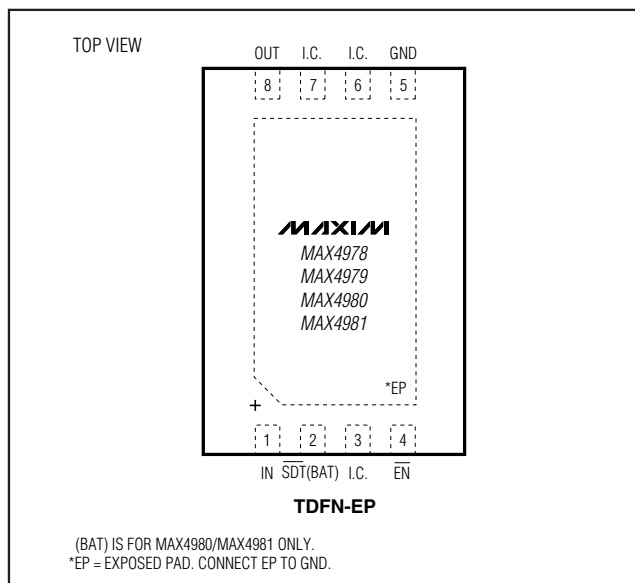

MAX4978-MAX4981

Ordering Information/Selector Guide

PART	PIN-PACKAGE	CURRENT LIMIT (mA)	BATTERY MONITOR	UVLO (V)	OVLO (V)	TOP MARK	PKG CODE
MAX4978ETA+	8 TDFN-EP*	900	No	4.4	5.7	AAK	T823-1
MAX4979ETA+**	8 TDFN-EP*	900	No	2.63	6.8	AAL	T823-1
MAX4980ETA+	8 TDFN-EP*	900	Yes	2.63	5.7	AAM	T823-1
MAX4981ETA+	8 TDFN-EP*	1950	Yes	2.63	5.7	AAN	T823-1

Note: All devices specified over the -40°C to +85°C operating temperature range.

+Denotes a lead-free package.

*EP = Exposed pad.

**Future product—contact factory for availability.



Maxim Integrated Products 1

For pricing, delivery, and ordering information, please contact Maxim Direct at 1-888-629-4642, or visit Maxim's website at www.maxim-ic.com.

Overvoltage Protector with Active Current Limit

ABSOLUTE MAXIMUM RATINGS

(Voltages referenced to GND.)

IN, SDT	-0.3V to +30V
OUT	-0.3V to IN
EN, BAT	-0.3V to +6V
SDT Continuous Current	±50mA
Continuous Power Dissipation (T _A = +70°C)	
8-Pin 2mm x 3mm TDFN (derate 16.7mW/°C above +70°C)	1333mW

Junction-to-Case Thermal Resistance (θ_{JC}) (Note 1)

 8-Pin 2mm x 3mm TDFN 10.8°C/W

Junction-to-Ambient Thermal Resistance (θ_{JA}) (Note 1)

 8-Pin 2mm x 3mm TDFN 60°C/W

Operating Temperature Range -40°C to +85°C

Junction Temperature +150°C

Storage Temperature Range -65°C to +150°C

Lead Temperature (soldering, 10s) +300°C

Note 1: Package thermal resistances were obtained using the method described in JEDEC specification JESD51-7, using a 4-layer board. For detailed information on package thermal considerations, refer to www.maxim-ic.com/thermal-tutorial.

Stresses beyond those listed under "Absolute Maximum Ratings" may cause permanent damage to the device. These are stress ratings only, and functional operation of the device at these or any other conditions beyond those indicated in the operational sections of the specifications is not implied. Exposure to absolute maximum rating conditions for extended periods may affect device reliability.

ELECTRICAL CHARACTERISTICS

(V_{IN} = 5.0V, V_{EN} = 0V, T_A = -40°C to +85°C, unless otherwise noted. Typical values are at T_A = +25°C.) (Note 2)

PARAMETER	SYMBOL	CONDITIONS	MIN	TYP	MAX	UNITS	
Input Voltage Range	V _{IN}		2.3		28	V	
Input Supply Current	I _{IN}	I _{OUT} < I _{LIM_MIN}		130	190	μA	
UVLO Supply Current	I _{UVLO}	V _{IN} = 2.3V		35	60	μA	
Shutdown Supply Current	I _{SHDN}	V _{EN} = 5V		15	23	μA	
IN Undervoltage Lockout	V _{UVLO}	MAX4978	V _{IN} falling	4.2			V
			V _{IN} rising	4.3	4.4	4.5	
		MAX4979/MAX4980/ MAX4981	V _{IN} falling	2.5			
			V _{IN} rising	2.56	2.63	2.70	
IN Undervoltage Lockout Hysteresis			1			%	
IN Overvoltage Lockout	V _{OVLO}	MAX4978/MAX4980/ MAX4981	V _{IN} falling	5.5			V
			V _{IN} rising	5.6	5.7	5.8	
		MAX4979	V _{IN} falling	6.5			
			V _{IN} rising	6.65	6.80	6.95	
IN Overvoltage Lockout Hysteresis			1			%	
BAT Overvoltage Trip Level	V _{BOTL}	MAX4980/MAX4981, V _{BAT} rising	4.3	4.4	4.5	V	
BAT Overvoltage Hysteresis		MAX4980/MAX4981		1		%	
BAT Input Leakage Current	I _{LKGB}	MAX4980/MAX4981, V _{BAT} = 4.2V			1	μA	
Switch On-Resistance	R _{ON}	I _{OUT} = 100mA		85	160	mΩ	
Overcurrent Protection Threshold	I _{LIM}	MAX4978, MAX4979, MAX4980	T _A = +25°C	850	900	950	mA
			T _A = 0°C to +85°C	800		1000	
			T _A = -40°C to +0°C	780		1000	
		MAX4981	T _A = +25°C	1850	1950	2050	
			T _A = -40°C to +85°C	1750	1950	2150	
Thermal Shutdown	T _{SHDN}	T _A rising		160		°C	

Overvoltage Protector with Active Current Limit

MAX4978-MAX4981

ELECTRICAL CHARACTERISTICS (continued)

($V_{IN} = 5.0V$, $V_{\overline{EN}} = 0V$, $T_A = -40^{\circ}C$ to $+85^{\circ}C$, unless otherwise noted. Typical values are at $T_A = +25^{\circ}C$.) (Note 2)

PARAMETER	SYMBOL	CONDITIONS	MIN	TYP	MAX	UNITS
Thermal-Shutdown Hysteresis				10		$^{\circ}C$
\overline{EN} Input High Voltage	V_{IH}		1.5			V
\overline{EN} Input Low Voltage	V_{IL}				0.6	V
\overline{EN} Input Leakage Current	I_{LKGE}	$V_{\overline{EN}} = 5.5V$ or $0V$	-1		+1	μA
\overline{SDT} Output Low Voltage	V_{OL}	MAX4978/MAX4979, $I_{SINK} = 20mA$			1	V
\overline{SDT} Leakage Current	I_{LKGS}	MAX4978/MAX4979, $V_{\overline{SDT}} = 28V$, \overline{SDT} deasserted			1	μA
DYNAMIC (Note 3)						
IN Debounce Time	t_{DEB}	$V_{UVLO} < V_{IN} < V_{OVLO}$ to charge-pump enable, Figure 1	120	160	200	ms
Switch Turn-On Time	t_{ON}	Time from $V_{OUT} = 10\%$ of V_{IN} to $V_{OUT} = 90\%$ of V_{IN} , $R_L = 10\Omega$, $C_L = 10\mu F$		1.5		ms
Switch Turn-Off Time	t_{OFF}	$V_{IN} < V_{UVLO}$ or $V_{IN} > V_{OVLO}$ to internal switch off, $R_L = 1k\Omega$		5	15	μs
Current-Limit Blanking Time	t_{BLANK}	Short circuit applied, Figure 1	15	20	25	ms
Current-Limit Reaction Time	t_{REAC}	Short circuit applied		5		μs
Overcurrent Autoretry Time	t_{RETRY}	Figure 1	120	160	200	ms

Note 2: All devices are 100% production tested at $T_A = +25^{\circ}C$. Specifications over $-40^{\circ}C$ to $+85^{\circ}C$ are guaranteed by design.

Note 3: All timing is measured using 10% and 90% levels, unless otherwise noted.

Overshoot Protector with Active Current Limit

Timing Diagram

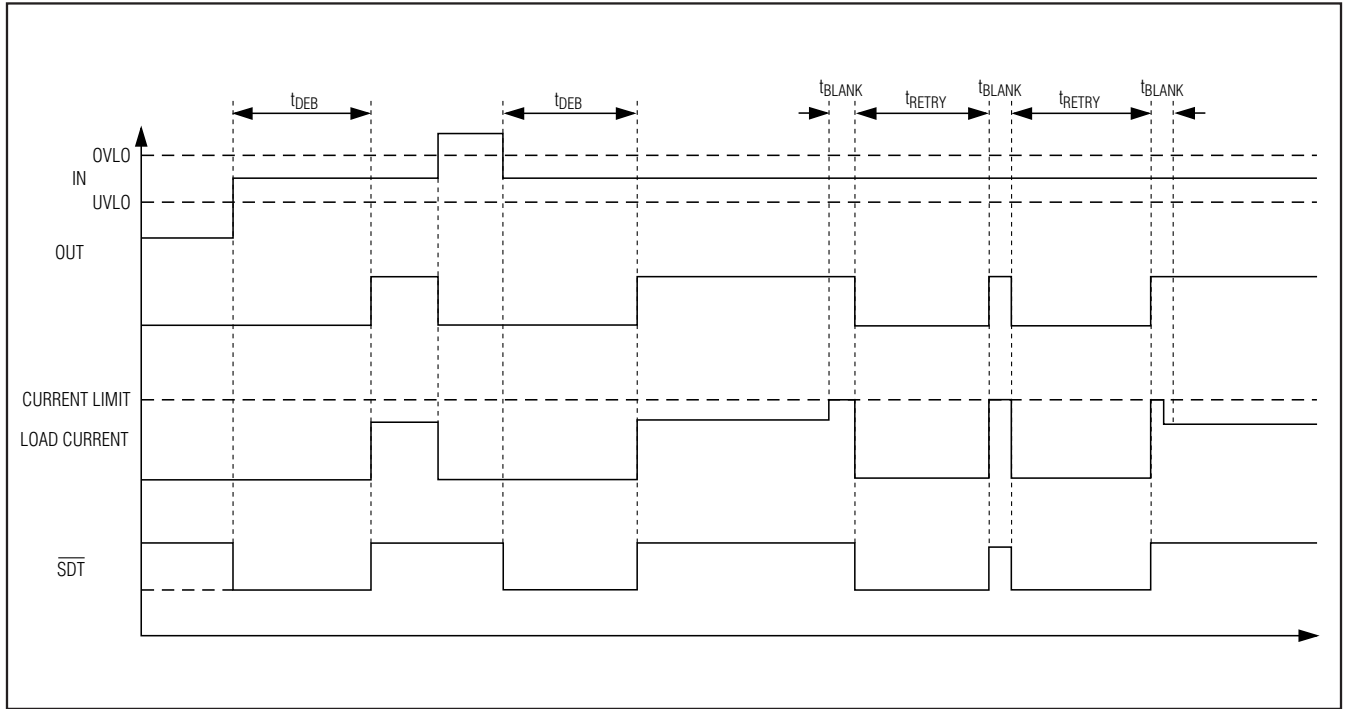

Figure 1. Timing Diagram

Overvoltage Protector with Active Current Limit

Typical Operating Characteristics

($V_{IN} = 5.0V$, $\overline{EN} = GND$, $T_A = +25^\circ C$, unless otherwise noted.)

MAX4978-MAX4981

SUPPLY CURRENT vs. SUPPLY VOLTAGE

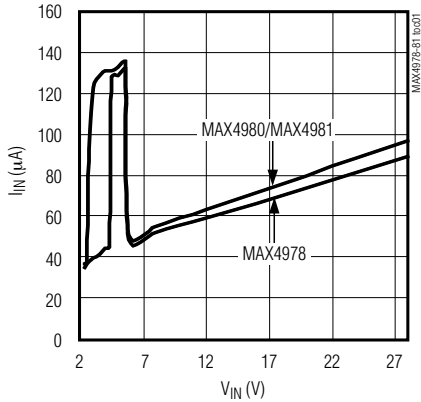

NORMALIZED ON-RESISTANCE vs. TEMPERATURE

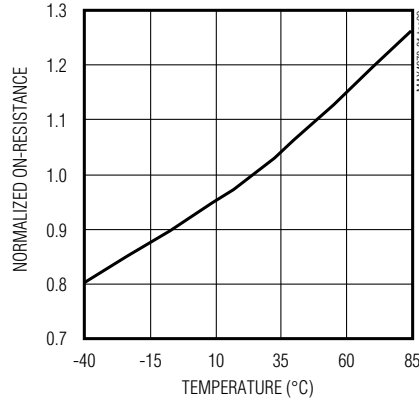

NORMALIZED UVLO THRESHOLD vs. TEMPERATURE

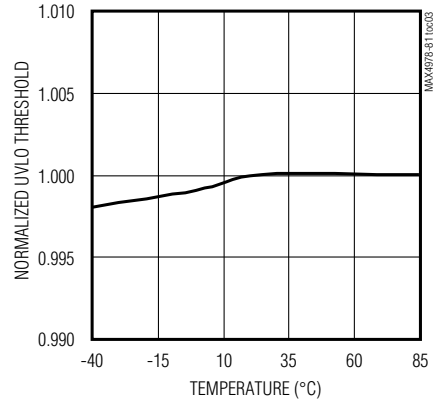

NORMALIZED OVLO THRESHOLD vs. TEMPERATURE

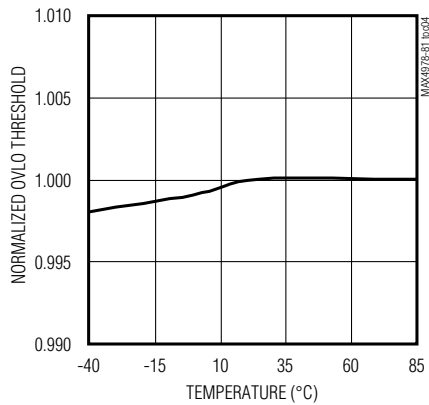

BATTERY OVERVOLTAGE THRESHOLD vs. TEMPERATURE

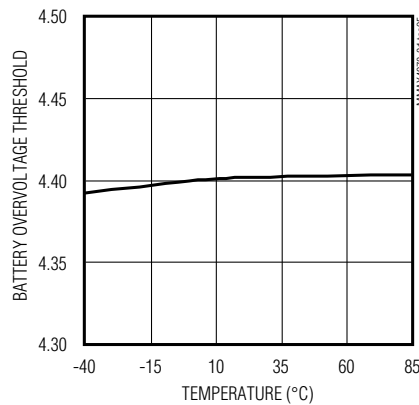

NORMALIZED CURRENT LIMIT vs. TEMPERATURE

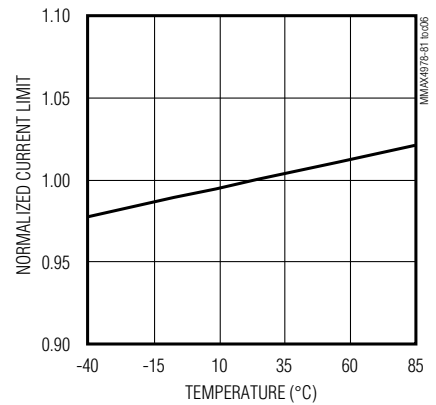

NORMALIZED STARTUP DELAY/AUTORETRY/BLANKING TIME vs. TEMPERATURE

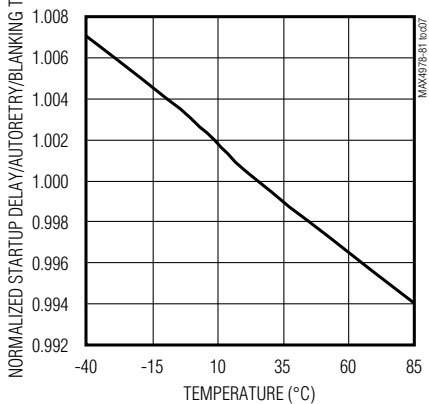

POWER-UP RESPONSE

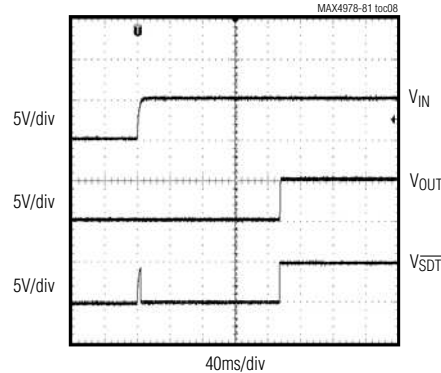

OVERVOLTAGE FAULT RESPONSE

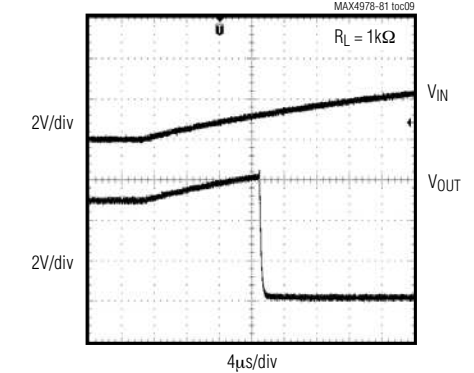

Overvoltage Protector with Active Current Limit

Typical Operating Characteristics (continued)

($V_{IN} = 5.0V$, $\overline{EN} = GND$, $T_A = +25^\circ C$, unless otherwise noted.)

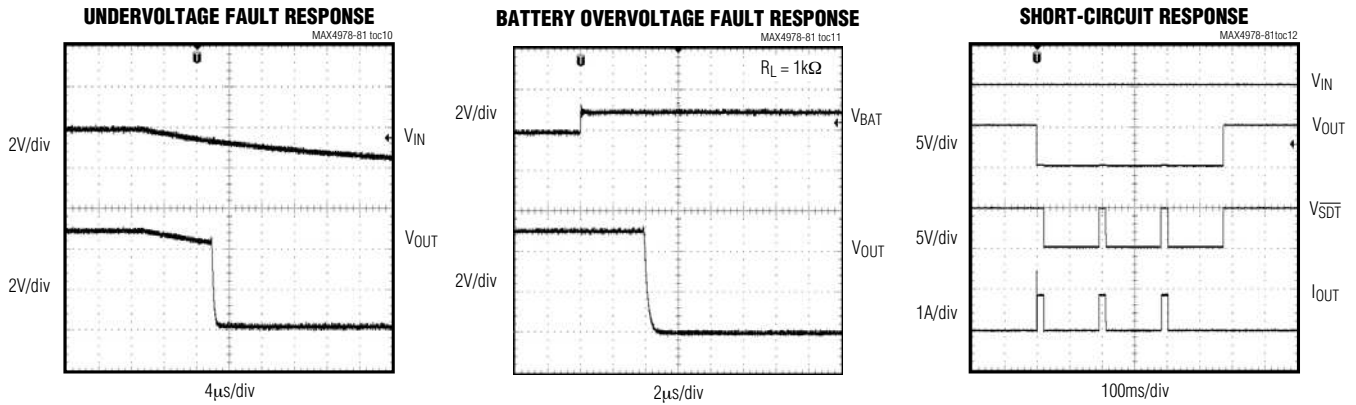

Pin Description

PIN		NAME	FUNCTION
MAX4978/ MAX4979	MAX4980/ MAX4981		
1	1	IN	Supply Voltage Input. IN powers the charge pump required to turn on the internal FET. When the correct adapter is plugged in, a 160ms debounce timer prevents a false turn-on of the internal FET. Bypass IN to GND with a 1 μ F ceramic capacitor as close to the device as possible to enable $\pm 15kV$ (HBM) ESD protection.
2	—	\overline{SDT}	Startup Debounce Time Indicator. \overline{SDT} is an active-low open-drain output that asserts low during the debounce/autoretry time.
—	2	BAT	Battery Monitor Input. Connect BAT to Li-ion battery terminal. Bypass BAT to GND with a 1 μ F ceramic capacitor as close to the device as possible to enable $\pm 15kV$ (HBM) ESD protection.
3, 6, 7	3, 6, 7	I.C.	Internally Connected. Connect I.C. to GND.
4	4	\overline{EN}	Active-Low Enable Input. Drive \overline{EN} low for normal operation. Drive \overline{EN} high to disable the device.
5	5	GND	Ground
8	8	OUT	Output Voltage. Output of internal FET.
—	—	EP	Exposed Pad. Internally connected to GND. Connect EP to a large ground plane to maximize thermal performance. Do not use EP as the sole GND connection.

Overvoltage Protector with Active Current Limit

MAX4978/MAX4979 Functional Diagram

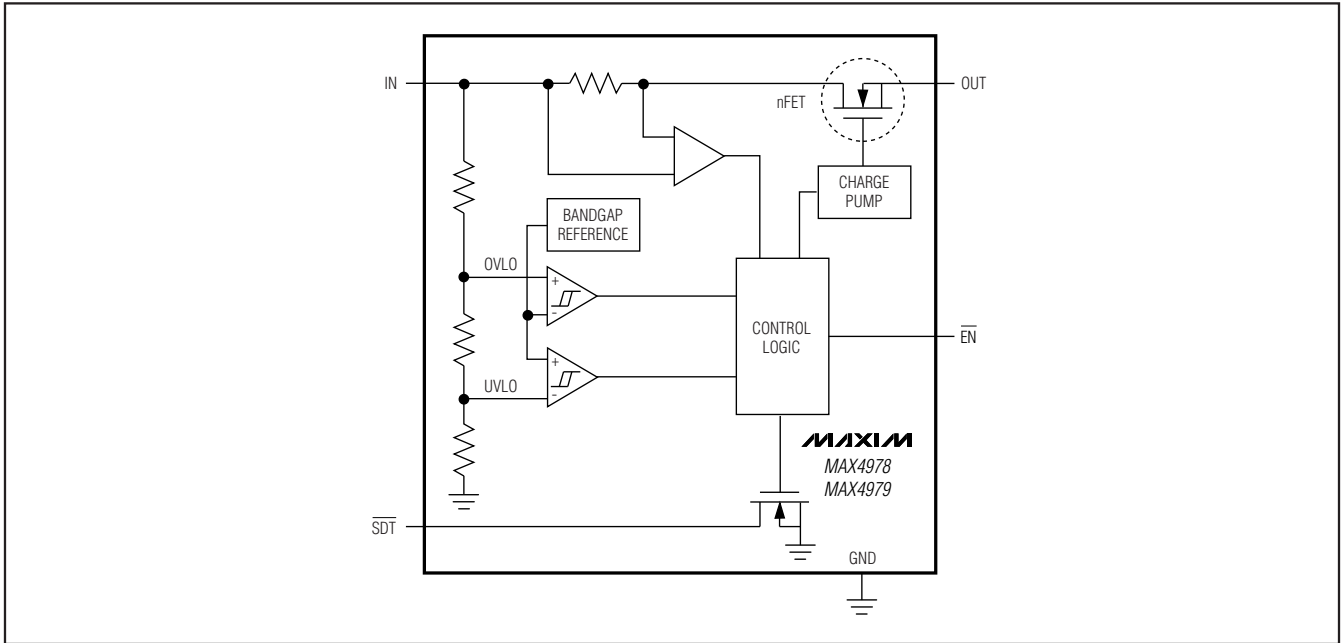

MAX4978-MAX4981

MAX4980/MAX4981 Functional Diagram

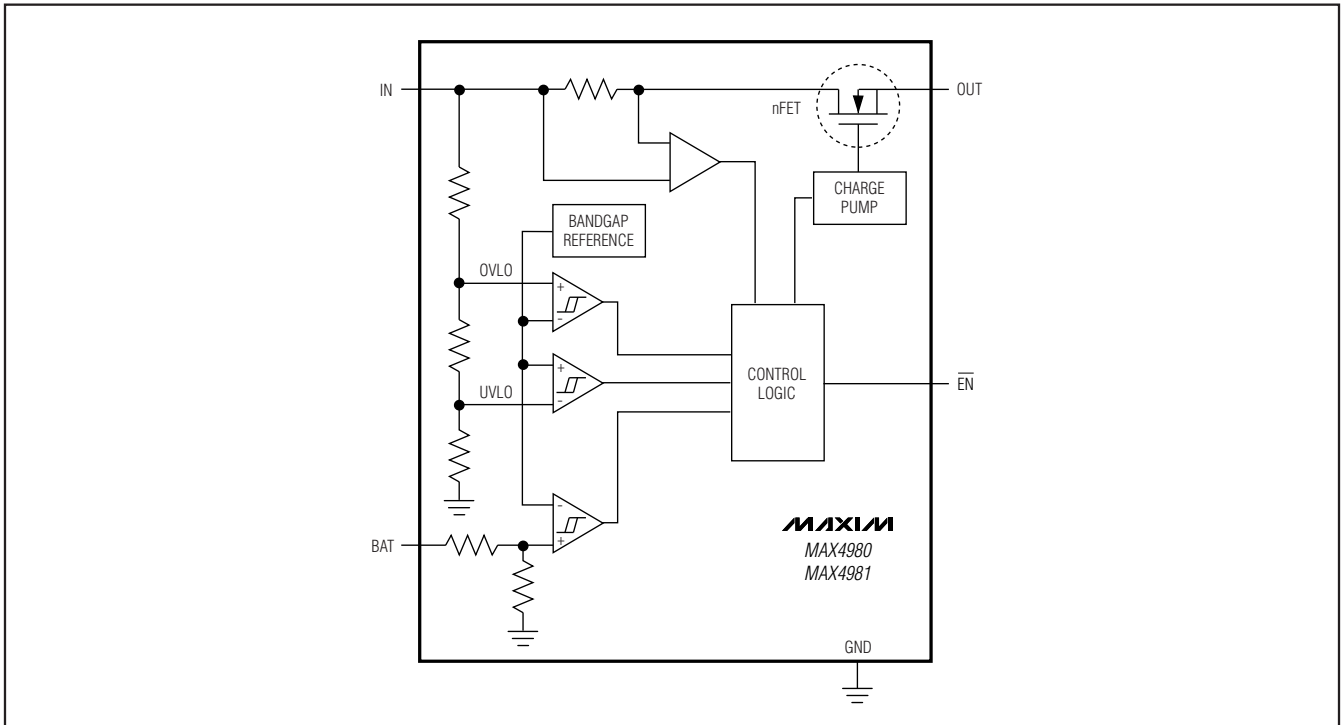

Overvoltage Protector with Active Current Limit

Detailed Description

The MAX4978–MAX4981 family of devices is a combination of an overvoltage protector, overcurrent limiter, and lithium-ion battery overcharge protector (MAX4980/MAX4981). These devices feature a low $85\text{m}\Omega$ (typ) R_{ON} FET and are used to protect the charger input port on a portable device. If the input voltage exceeds the overvoltage threshold (OVLO) or falls below the undervoltage threshold (UVLO), the FET is turned off to prevent damage to the protected components. The internal charge pump's 160ms debounce time prevents false turn-on of the internal FET during startup. $\overline{\text{SDT}}$ is an active-low open-drain output that asserts low during the debounce time after a valid voltage is applied to the input (MAX4978/MAX4979).

The MAX4978–MAX4981 feature an overcurrent limiter as a second layer of protection for a lithium-ion battery charger that limits current to a 900mA (MAX4978/MAX4979/MAX4980) or 1950mA (MAX4981) threshold for a 20ms blanking time. At the end of the blanking time, if current is still at the threshold, the FET is turned off and the device restarts the cycle after 160ms. The battery voltage monitor measures the voltage of a lithium-ion battery and disables the FET if the battery voltage exceeds 4.4V (MAX4980/MAX4981).

Autoretry

When the current-limit threshold is reached, the t_{BLANK} timer begins counting. The timer resets if the overcurrent condition disappears before t_{BLANK} has elapsed. A retry time delay, t_{RETRY} , is started immediately after t_{BLANK} has elapsed and during that time, the FET is off. At the end of t_{RETRY} , the FET is turned on again. If the fault still exists, the cycle is repeated. If the fault has been removed, the FET stays on.

Undervoltage Lockout (UVLO)

The MAX4978 has a 4.4V UVLO threshold, while the MAX4979/MAX4980/MAX4981 have a 2.63V UVLO threshold. When an undervoltage lockout condition occurs with high load current, the voltage at the input to the UVLO comparator may recover due to internal parasitic resistance causing the device to restart.

Overvoltage Lockout (OVLO)

The MAX4979 has a 6.8V OVLO threshold, while the MAX4978/MAX4980/MAX4981 have a 5.7V OVLO threshold.

Battery Overcharge Protector (MAX4980/MAX4981)

The MAX4980/MAX4981 feature a battery overcharge protection input (BAT) that triggers a voltage fault, turning off the FET, when V_{BAT} exceeds 4.4V.

Startup Debounce Time Indicator ($\overline{\text{SDT}}$) (MAX4978/MAX4979)

$\overline{\text{SDT}}$ is an open-drain output that asserts low during the startup debounce time and during the autoretry time. $\overline{\text{SDT}}$ returns to high impedance once the charge pump turns on. This feature is useful for discharging the AC adapter capacitance during the startup debounce time (Figures 1, 2).

Thermal Shutdown Protection

The MAX4978–MAX4981 have a thermal-shutdown feature to protect the devices from overheating. The device immediately turns off when the junction temperature exceeds $+160^{\circ}\text{C}$ (typ). These devices exit thermal shutdown after the junction temperature cools by 10°C (typ).

$\overline{\text{EN}}$ Input

$\overline{\text{EN}}$ is an active-low enable input. Drive $\overline{\text{EN}}$ low for normal operation. Drive $\overline{\text{EN}}$ high to disable the device.

Applications Information

IN Bypass Capacitor

For most applications, bypass IN to GND with a $1\mu\text{F}$ ceramic capacitor as close to the device as possible to enable $\pm 15\text{kV}$ (HBM) ESD protection on IN. If the power source has significant inductance due to long lead length, take care to prevent overshoots due to the LC tank circuit and provide protection if necessary to prevent exceeding the 30V absolute maximum rating on IN.

BAT Bypass Capacitor

For most applications, bypass BAT to GND with a $1\mu\text{F}$ ceramic capacitor as close to the device as possible to enable $\pm 15\text{kV}$ (HBM) ESD protection on BAT. If high ESD protection is not necessary, no capacitor is required on BAT.

ESD Test Conditions

ESD performance depends on a number of conditions. The MAX4978–MAX4981 are specified for $\pm 15\text{kV}$ (HBM) typical ESD resistance on IN and BAT when IN and BAT are bypassed to ground with a $1\mu\text{F}$ low ESR ceramic capacitor. Contact Maxim for a reliability report that documents test setup, methodology, and results.

Overvoltage Protector with Active Current Limit

MAX4978-MAX4981

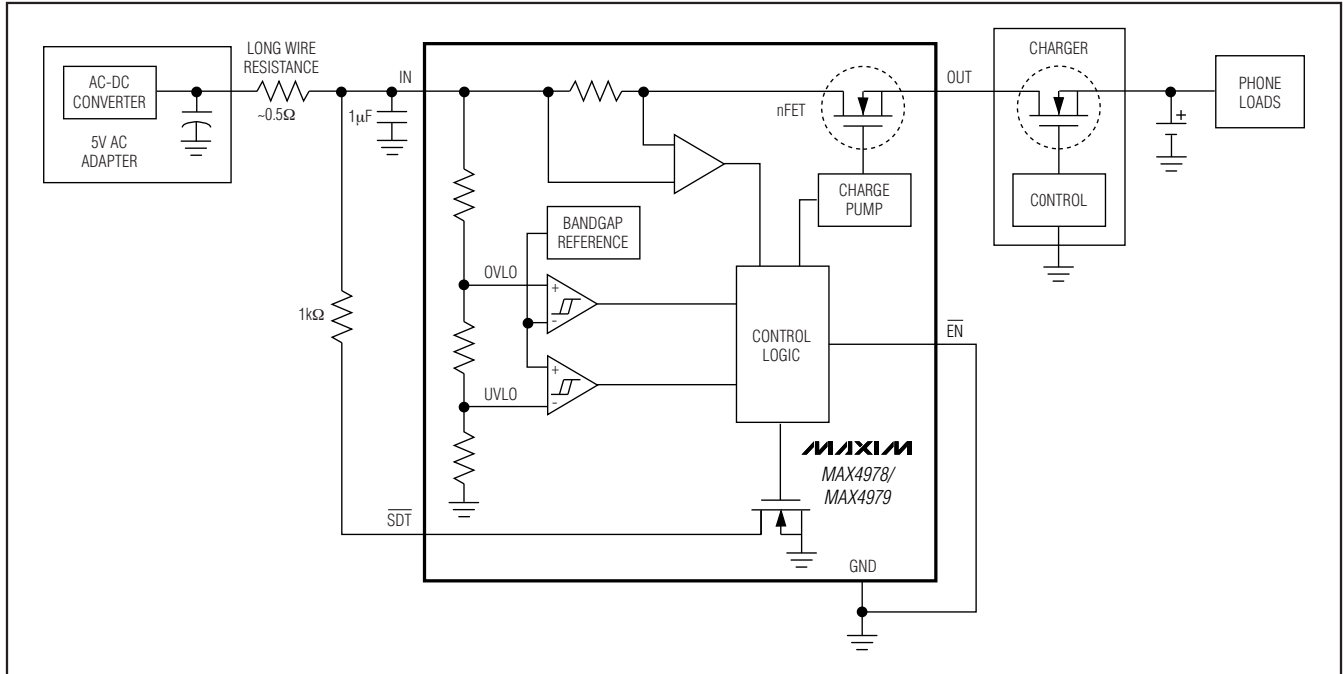

Figure 2. Typical Application Circuit with \overline{SDT}

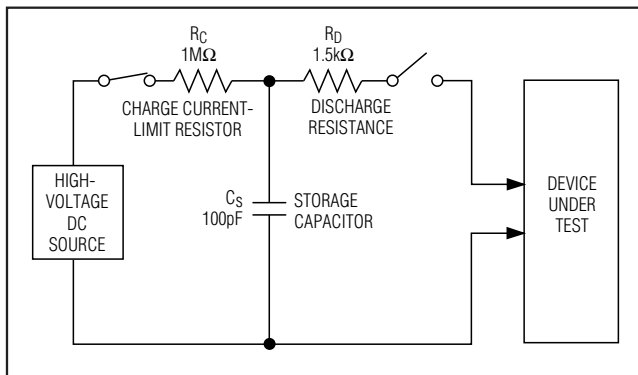

Figure 3. Human Body ESD Test Model

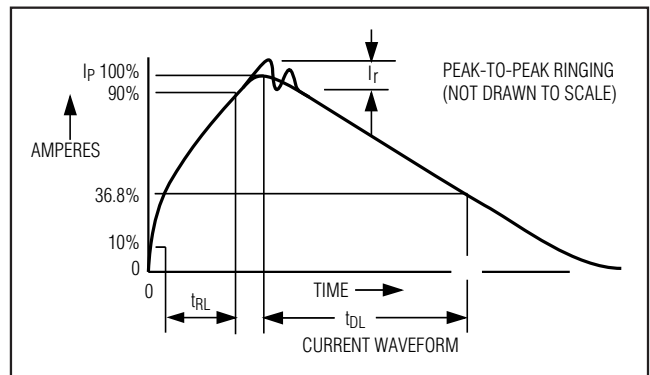

Figure 4. Human Body Current Waveform

Human Body Model

Figure 3 shows the Human Body Model, and Figure 4 shows the current waveform it generates when discharged into a low impedance. This model consists of a 100pF capacitor charged to the ESD voltage of interest that is then discharged into the device through a 1.5kΩ resistor.

Chip Information

PROCESS: BiCMOS

Overvoltage Protector with Active Current Limit

Typical Application Circuit

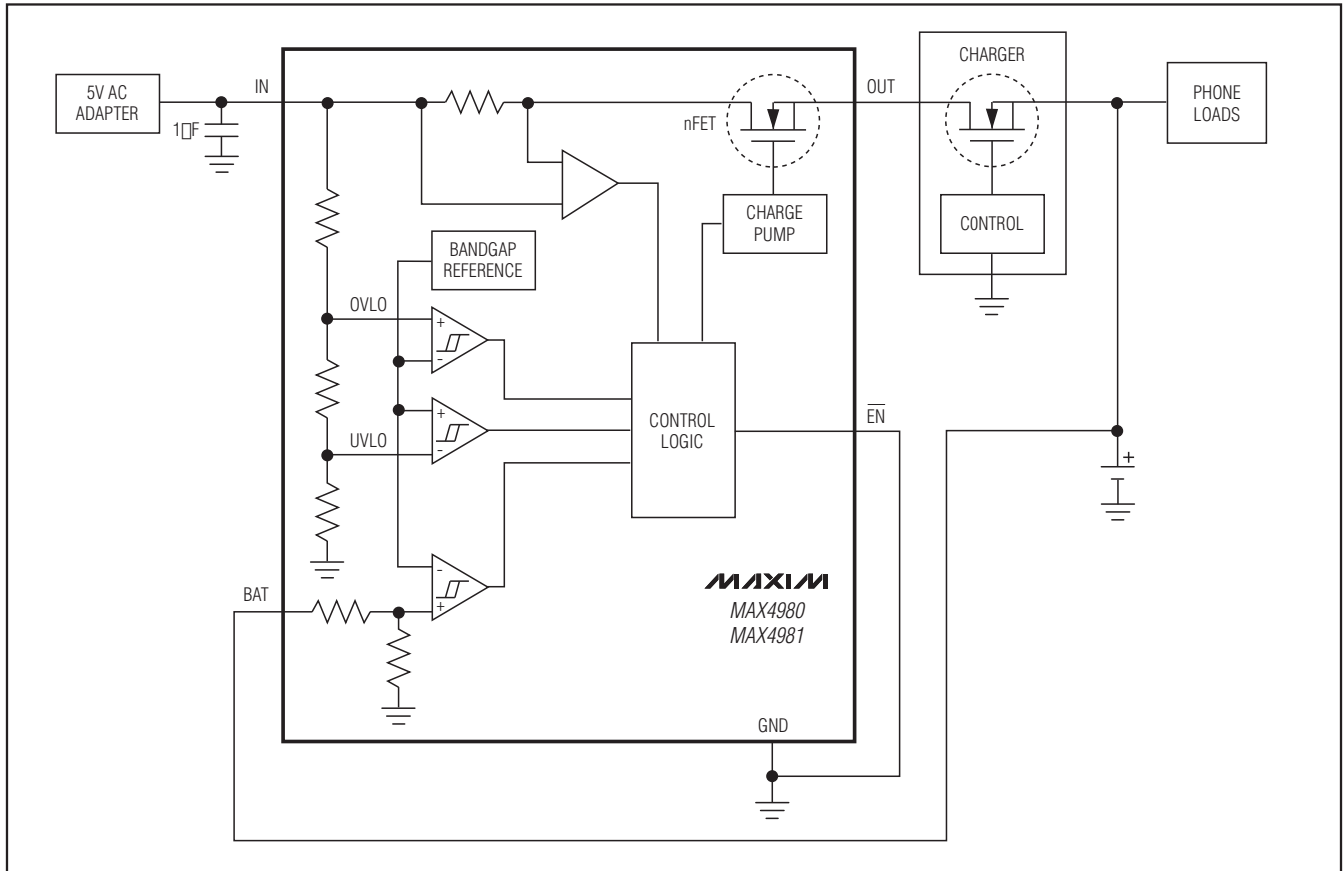

Package Information

For the latest package outline information and land patterns, go to www.maxim-ic.com/packages.

PACKAGE TYPE	PACKAGE CODE	DOCUMENT NO.
8 TDFN-EP	T823-1	21-0174

Maxim cannot assume responsibility for use of any circuitry other than circuitry entirely embodied in a Maxim product. No circuit patent licenses are implied. Maxim reserves the right to change the circuitry and specifications without notice at any time.

10 **Maxim Integrated Products, 120 San Gabriel Drive, Sunnyvale, CA 94086 408-737-7600**