



Chipsmall Limited consists of a professional team with an average of over 10 year of expertise in the distribution of electronic components. Based in Hongkong, we have already established firm and mutual-benefit business relationships with customers from,Europe,America and south Asia,supplying obsolete and hard-to-find components to meet their specific needs.

With the principle of “Quality Parts,Customers Priority,Honest Operation,and Considerate Service”,our business mainly focus on the distribution of electronic components. Line cards we deal with include Microchip,ALPS,ROHM,Xilinx,Pulse,ON,Everlight and Freescale. Main products comprise IC,Modules,Potentiometer,IC Socket,Relay,Connector.Our parts cover such applications as commercial,industrial, and automotives areas.

We are looking forward to setting up business relationship with you and hope to provide you with the best service and solution. Let us make a better world for our industry!



## Contact us

Tel: +86-755-8981 8866 Fax: +86-755-8427 6832

Email & Skype: info@chipsmall.com Web: www.chipsmall.com

Address: A1208, Overseas Decoration Building, #122 Zhenhua RD., Futian, Shenzhen, China





## MAX4989 Evaluation Kit

Evaluates: MAX4989

### General Description

The MAX4989 evaluation kit (EV kit) provides a proven design to evaluate the MAX4989 Hi-Speed 2-of-4 USB 2.0 crosspoint switch. The EV kit contains two sub circuits, a typical USB crosspoint switch application (top half), and a test circuit (bottom half).

The USB crosspoint switch application circuit is USB powered by the USB host. USB input/output connectors are also provided to easily interface with USB devices. All USB signal traces are 90Ω differential controlled-impedance traces.

A separate test circuit is also provided at the bottom of the MAX4989 EV kit for eye diagram evaluation using SMA connections and 90Ω controlled-impedance traces.

The MAX4989 EV kit PCB comes with two MAX4989ETD+ devices installed. The MAX4989ETD+ is available in a lead(Pb)-free 14-pin, 3mm x 3mm TDFN package.

### Features

- ◆ USB Connectors for Inputs and Outputs
- ◆ USB Powered (Cable Included)
- ◆ Eye Diagram Test Circuit with SMA Input/Output
- ◆ Jumper-Selectable USB Channel Connection
- ◆ Lead(Pb)-Free and RoHS Compliant
- ◆ Proven PCB Layout
- ◆ Fully Assembled and Tested

### Ordering Information

PART	TYPE
MAX4989EVKIT+	EV Kit

+Denotes lead(Pb)-free and RoHS compliant.

### Component List

DESIGNATION	QTY	DESCRIPTION
C1–C4	4	0.1μF ±10%, 16V X7R ceramic capacitors (0603) TDK C1608X7R1C104K
D1, D2, D3	3	20V, 500mA Schottky diodes (SOD123) Fairchild Semi MBR0520L
J1, J2	2	USB type-B, right-angle PC-mount receptacles
J3, J4	2	USB type-A, right-angle PC-mount receptacles
JU1–JU6	6	3-pin headers
LED1, LED2	2	Orange LEDs (0603)

DESIGNATION	QTY	DESCRIPTION
R1, R2	2	680Ω ±5% resistors (0603)
R3–R6	0	Not installed, resistors (0603)
SMA1+, SMA1-, SMA2+, SMA2-	4	Edge-mount receptacle SMA connectors
U1, U2	2	USB 2.0 crosspoint switches (14 TDFN-EP*) Maxim MAX4989ETD+
—	6	Shunts
—	2	USB high-speed A-to-B cables, 6ft
—	1	PCB: MAX4989 EVALUATION KIT+

\*EP = Exposed pad.

### Component Suppliers

SUPPLIER	PHONE	WEBSITE
Fairchild Semiconductor	888-522-5372	www.fairchildsemi.com
TDK Corp.	847-803-6100	www.component.tdk.com

**Note:** Indicate that you are using the MAX4989 when contacting these component suppliers.



# MAX4989 Evaluation Kit

## Quick Start

### Required Equipment

- MAX4989 EV kit (2 USB cables included)
- User-supplied Windows® 2000/XP® or Windows Vista® PC with a spare USB port
- User-supplied USB signal source (e.g., USB 2.0 flash drive)

**Note:** In the following sections, text in **bold and underlined** refers to items from the Windows operating system.

### Procedure

The MAX4989 EV kit is fully assembled and tested. Follow the steps below to verify board operation:

- 1) Place a shunt across pins 2-3 of jumper JU1.
- 2) Place a shunt across pins 1-2 of jumper JU2.
- 3) Place a shunt across pins 2-3 of jumper JU3.
- 4) Connect the USB cable from the PC to the J1 USB connector on the EV kit.
- 5) Verify that LED1 turns on.
- 6) Connect the USB signal source to the J3 USB connector on the EV kit.
- 7) Go to the Windows **System Properties** window (Windows logo key + Pause Break key from keyboard) to locate and open the **Device Manager**. Under the **Universal Serial Bus Controllers** subject directory, verify that the USB 2.0 signal source is recognized through the USB port.

## Detailed Description of Hardware

The MAX4989 evaluation kit (EV kit) provides a proven design to evaluate the MAX4989 Hi-Speed 2-of-4 USB 2.0 crosspoint switch. The EV kit contains two sub circuits, a typical USB crosspoint switch application (top half), and a test circuit (bottom half).

### Application Circuit

The application circuit is located at the top of the board. Jumpers JU1, JU2, and JU3 are used to control the switch connection (see Table 1). The MAX4989 is powered from the USB port that is connected to the USB host. To use a user-supplied power supply, connect a 5V supply to the VCC and GND pads. All signal traces in the USB application circuit are 90Ω differential controlled-impedance traces.

### Test Diagram Circuit

A separate test circuit is also provided at the bottom of the MAX4989 EV kit for timing critical tests such as eye diagrams. The test circuit is powered by applying a 2.7V to 5.5V power supply at the VCC2 and GND2 pads.

**Table 1. Jumper Settings**

SHUNT POSITION			DESCRIPTION
JU1	JU2	JU3	
2-3	2-3	2-3	Shutdown
1-2	2-3	2-3	Illegal state
2-3	1-2	2-3	J1 and J3 connected
1-2	1-2	2-3	J2 and J3 connected
2-3	2-3	1-2	J2 and J4 connected
1-2	2-3	1-2	J1 and J4 connected
2-3	1-2	1-2	Illegal state
1-2*	1-2*	1-2*	Shutdown

\*Default position.

**Table 2. Test Circuit Jumper Settings**

SHUNT POSITION			DESCRIPTION
JU4	JU5	JU6	
2-3	1-2	2-3	On
All other combinations			Off

Windows, Windows XP, and Windows Vista are registered trademarks of Microsoft Corp.

# MAX4989 Evaluation Kit

Evaluate: **MAX4989**

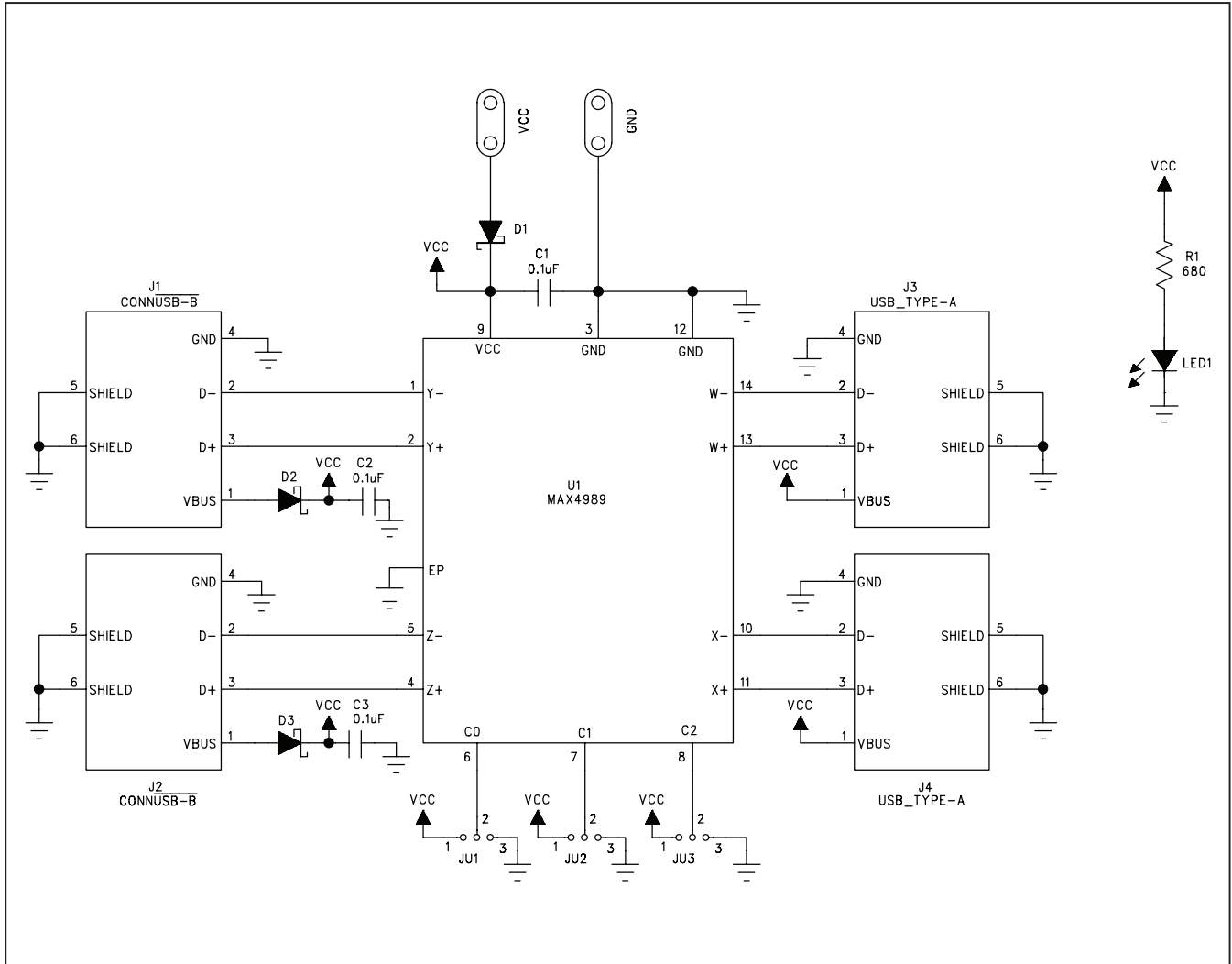

Figure 1a. MAX4989 EV Kit Schematic (Sheet 1 of 2)

# MAX4989 Evaluation Kit

Evaluates: MAX4989

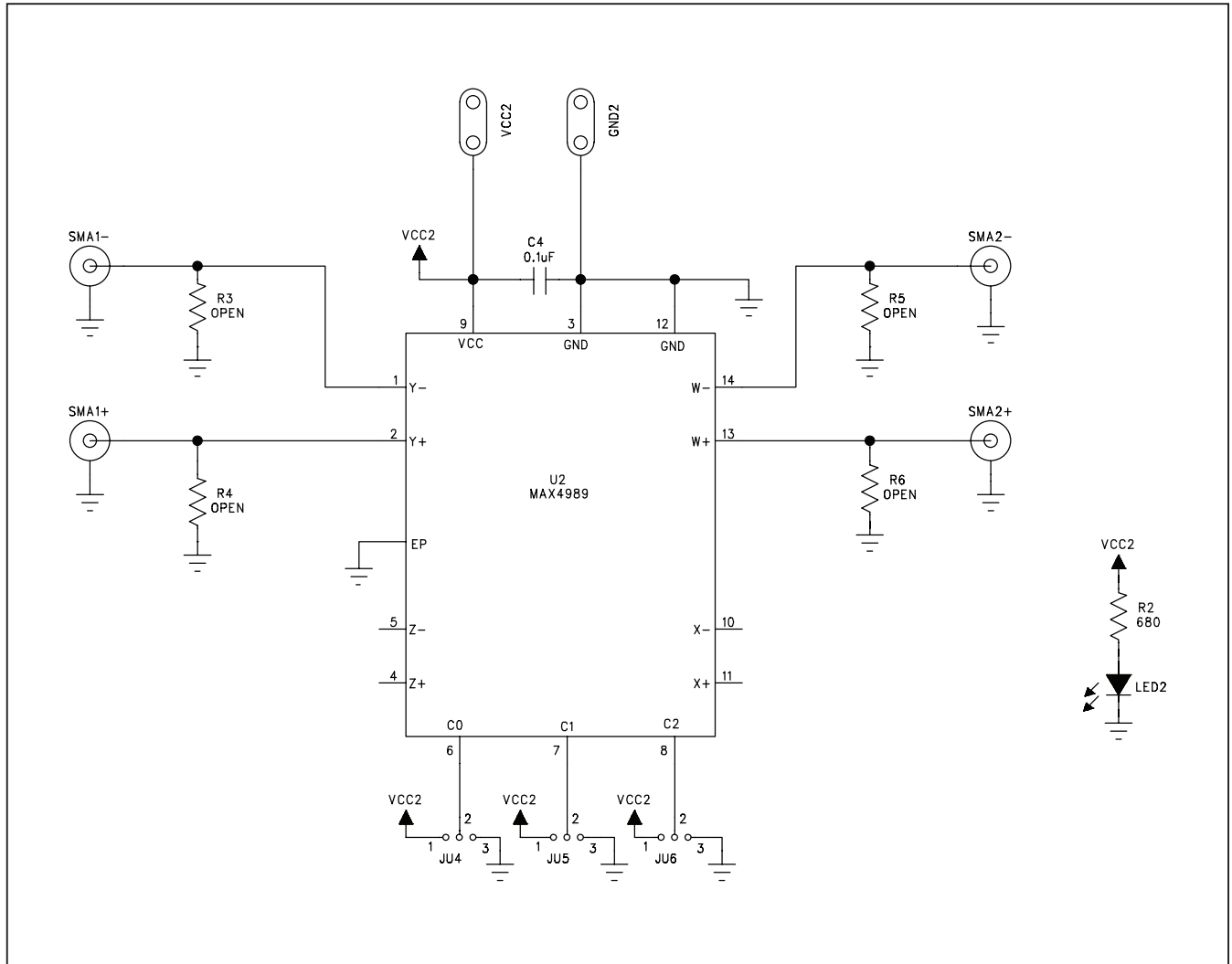

Figure 1b. MAX4989 EV Kit Schematic (Sheet 2 of 2)

# MAX4989 Evaluation Kit

Evaluates: MAX4989

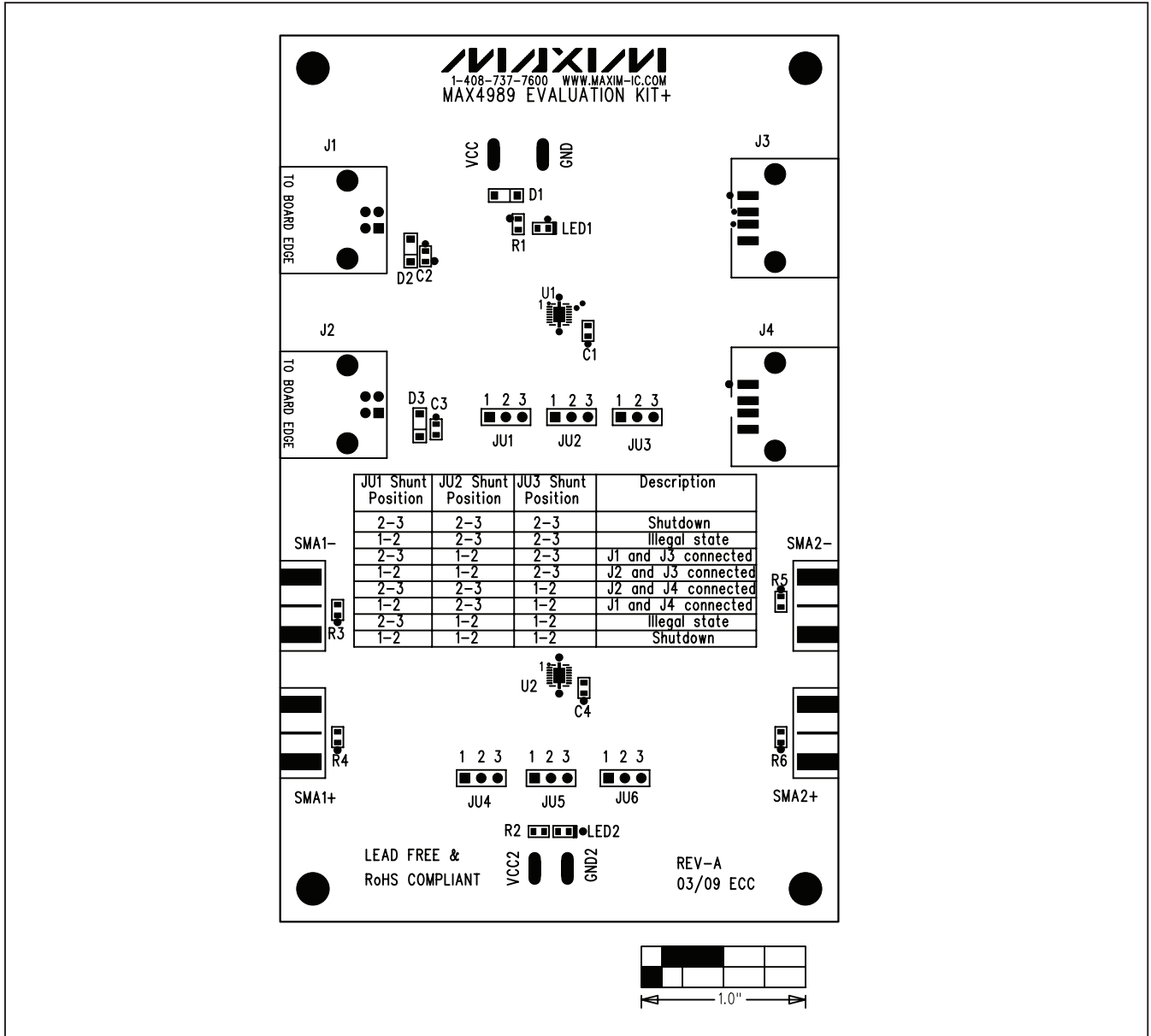

Figure 2. MAX4989 EV Kit Component Placement Guide—Component Side

# MAX4989 Evaluation Kit

Evaluates: MAX4989

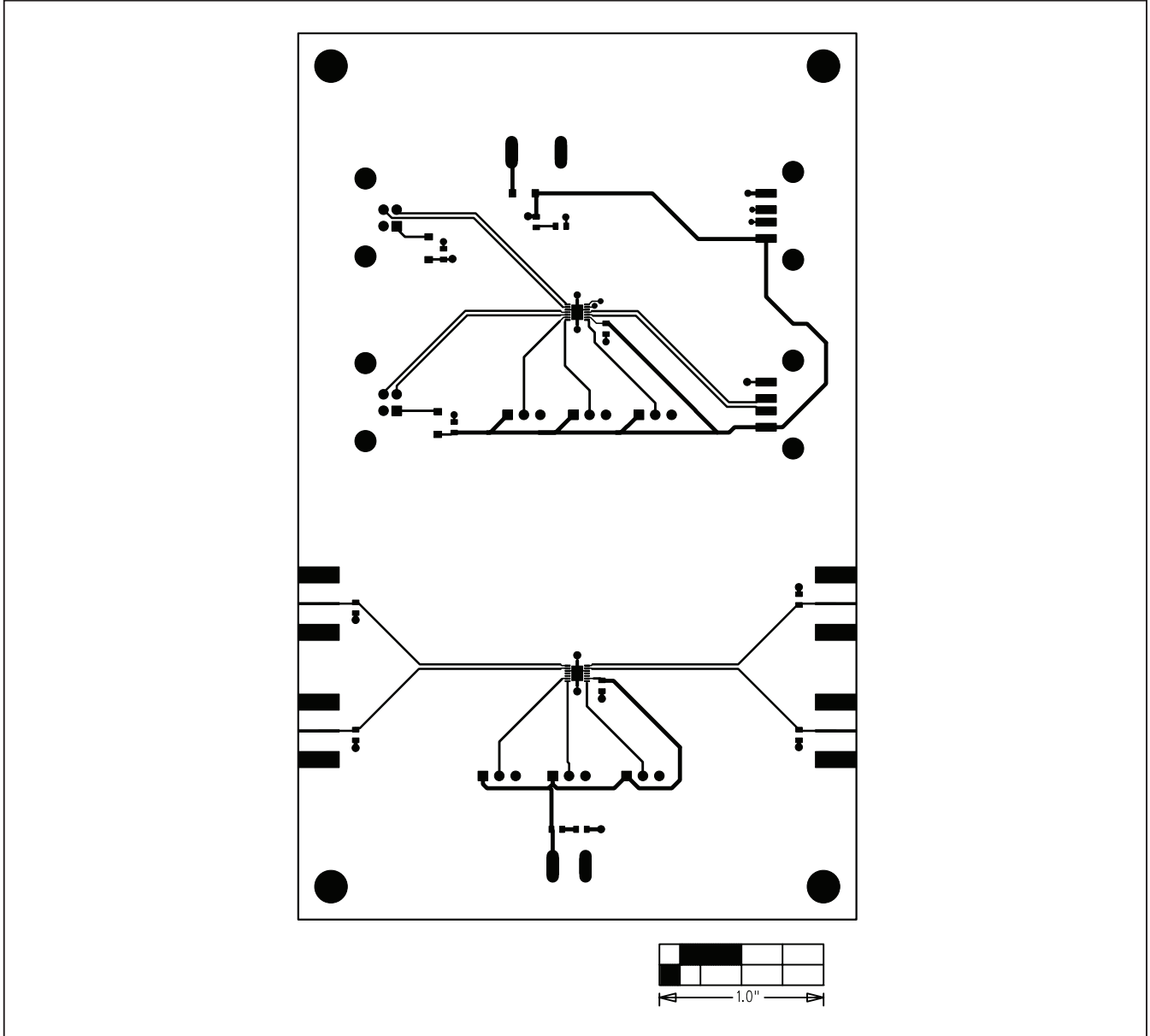

Figure 3. MAX4989 EV Kit PCB Layout—Component Side

# MAX4989 Evaluation Kit

Evaluates: **MAX4989**

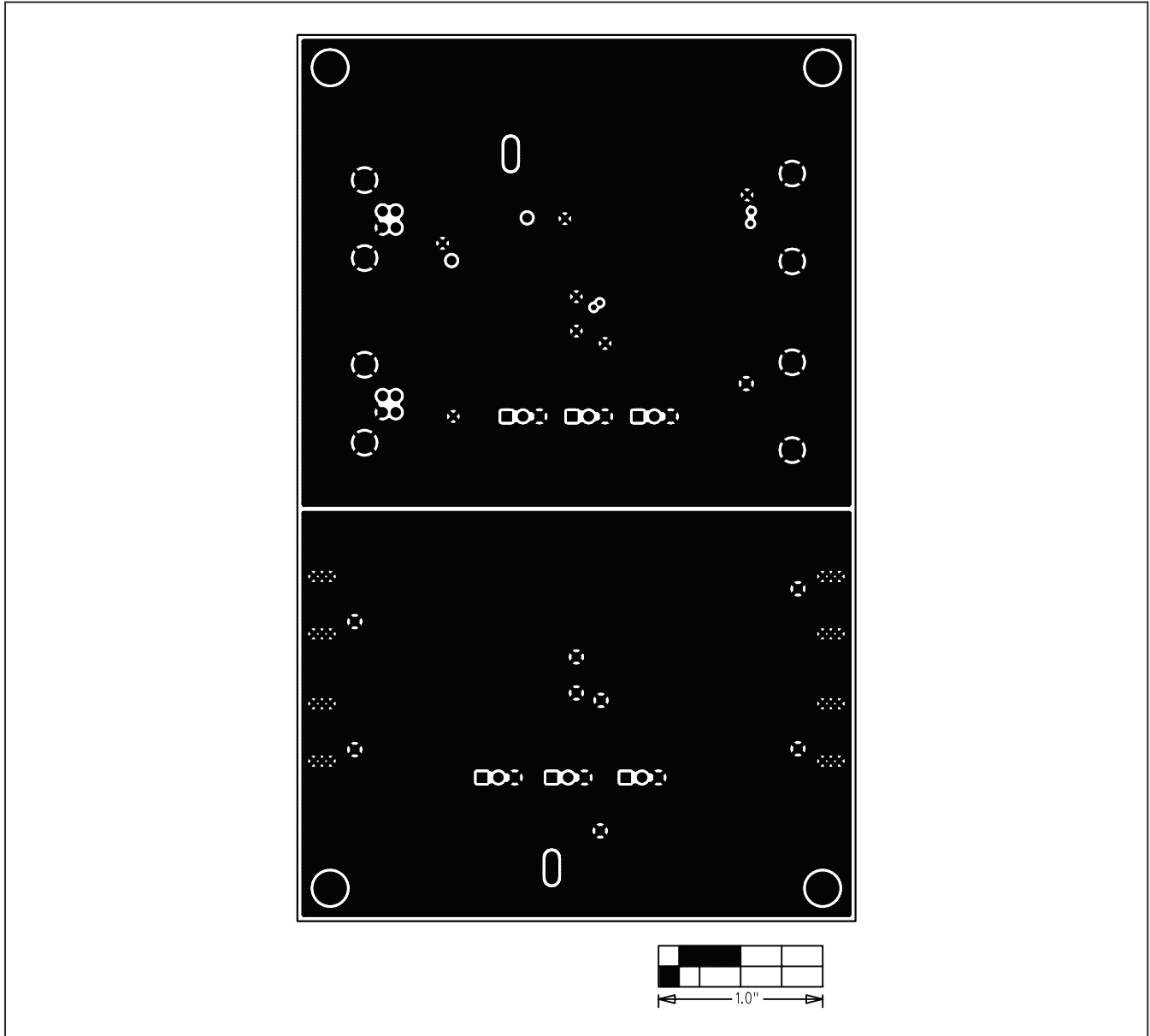

Figure 4. MAX4989 EV Kit PCB Layout—Layer 2



# MAX4989 Evaluation Kit

Evaluates: MAX4989

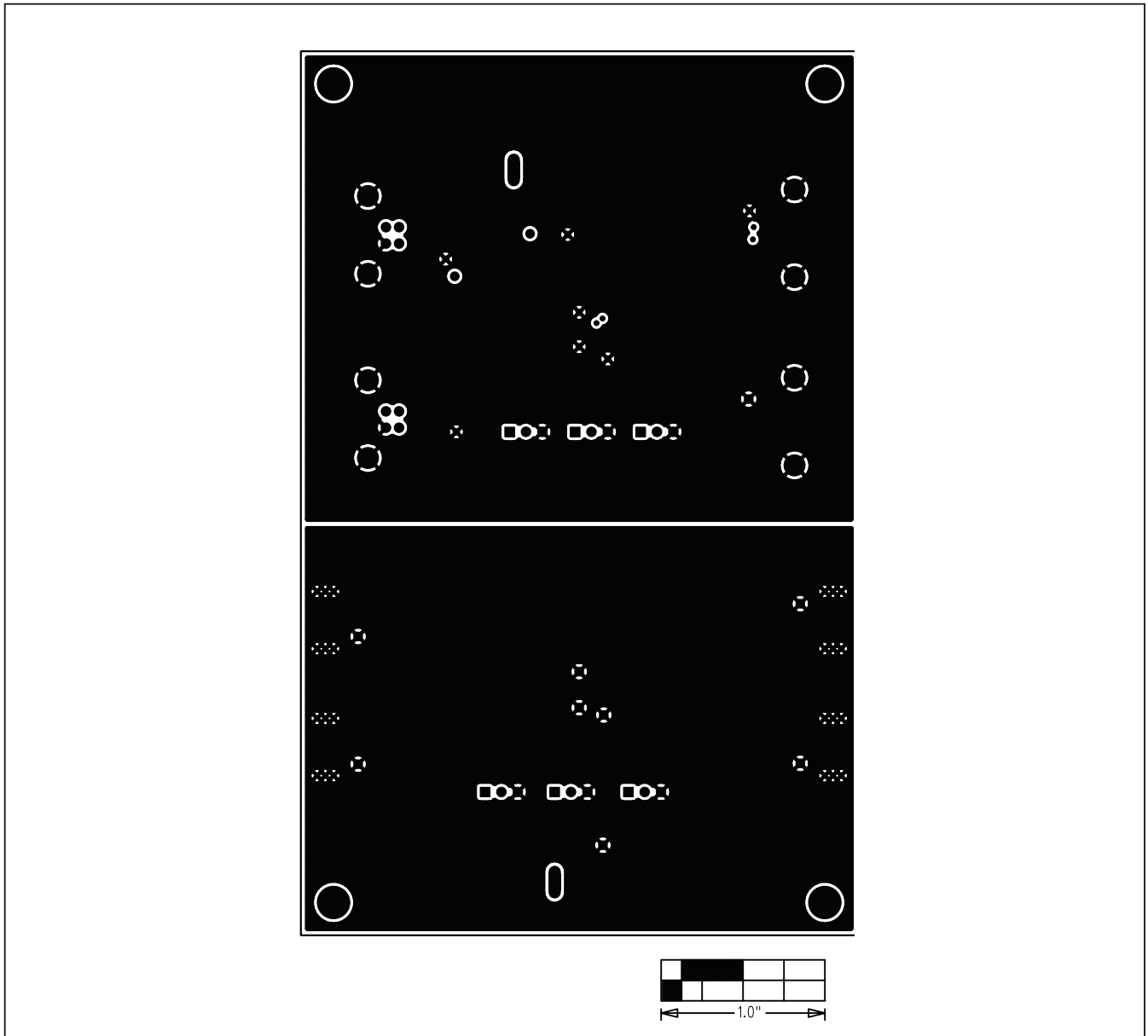

Figure 5. MAX4989 EV Kit PCB Layout—Layer 3

# MAX4989 Evaluation Kit

Evaluates: MAX4989

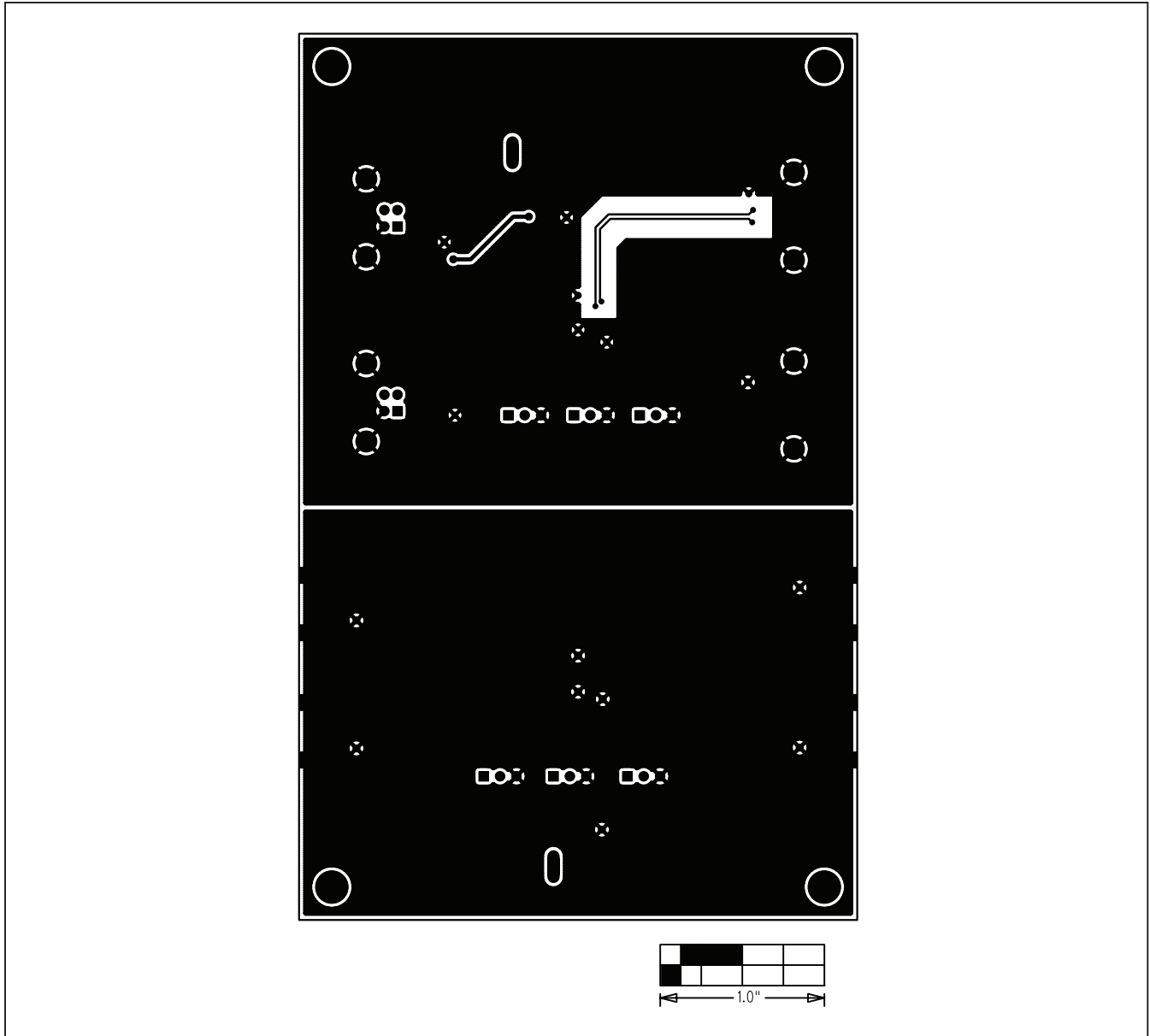

Figure 6. MAX4989 EV Kit PCB Layout—Solder Side

Maxim cannot assume responsibility for use of any circuitry other than circuitry entirely embodied in a Maxim product. No circuit patent licenses are implied. Maxim reserves the right to change the circuitry and specifications without notice at any time.

**Maxim Integrated Products, 120 San Gabriel Drive, Sunnyvale, CA 94086 408-737-7600** \_\_\_\_\_ **9**