



Chipsmall Limited consists of a professional team with an average of over 10 year of expertise in the distribution of electronic components. Based in Hongkong, we have already established firm and mutual-benefit business relationships with customers from,Europe,America and south Asia,supplying obsolete and hard-to-find components to meet their specific needs.

With the principle of “Quality Parts,Customers Priority,Honest Operation,and Considerate Service”,our business mainly focus on the distribution of electronic components. Line cards we deal with include Microchip,ALPS,ROHM,Xilinx,Pulse,ON,Everlight and Freescale. Main products comprise IC,Modules,Potentiometer,IC Socket,Relay,Connector.Our parts cover such applications as commercial,industrial, and automotives areas.

We are looking forward to setting up business relationship with you and hope to provide you with the best service and solution. Let us make a better world for our industry!



Contact us

Tel: +86-755-8981 8866 Fax: +86-755-8427 6832

Email & Skype: info@chipsmall.com Web: www.chipsmall.com

Address: A1208, Overseas Decoration Building, #122 Zhenhua RD., Futian, Shenzhen, China





CMOS, Quad, Serial-Interface 8-Bit DAC

MAX500

General Description

The MAX500 is a quad, 8-bit, voltage-output digital-to-analog converter (DAC) with a cascadable serial interface. The IC includes four output buffer amplifiers and input logic for an easy-to-use, two- or three-wire serial interface. In a system with several MAX500s, only one serial data line is required to load all the DACs by cascading them. The MAX500 contains double-buffered logic and a 10-bit shift register that allows all four DACs to be updated simultaneously using one control signal. There are three reference inputs so the range of two of the DACs can be independently set while the other two DACs track each other.

The MAX500 achieves 8-bit performance over the full operating temperature range without external trimming.

Applications

- Minimum Component Count Analog Systems
- Digital Offset/Gain Adjustment
- Industrial Process Control
- Arbitrary Function Generators
- Automatic Test Equipment

Features

- ◆ Buffered Voltage Outputs
- ◆ Double-Buffered Digital Inputs
- ◆ Microprocessor and TTL/CMOS Compatible
- ◆ Requires No External Adjustments
- ◆ Two- or Three-Wire Cascadable Serial Interface
- ◆ 16-Pin DIP/SO Package and 20-Pin LCC
- ◆ Operates from Single or Dual Supplies

Ordering Information

PART	TEMP. RANGE	PIN-PACKAGE	ERROR (LSB)
MAX500ACPE	0°C to +70°C	16 Plastic DIP	±1
MAX500BCPE	0°C to +70°C	16 Plastic DIP	±2
MAX500ACWE	0°C to +70°C	16 Wide SO	±1
MAX500BCWE	0°C to +70°C	16 Wide SO	±2
MAX500BC/D	0°C to +70°C	Dice*	±2
MAX500AEPE	-40°C to +85°C	16 Plastic DIP	±1
MAX500BEPE	-40°C to +85°C	16 Plastic DIP	±2
MAX500AEWE	-40°C to +85°C	16 Wide SO	±1
MAX500BEWE	-40°C to +85°C	16 Wide SO	±2
MAX500AEJE	-40°C to +85°C	16 CERDIP	±1
MAX500BEJE	-40°C to +85°C	16 CERDIP	±2
MAX500AMJE	-55°C to +125°C	16 CERDIP	±1
MAX500BMJE	-55°C to +125°C	16 CERDIP	±2
MAX500AML P	-55°C to +125°C	20 LCC	±1
MAX500BML P	-55°C to +125°C	20 LCC	±2

*Contact factory for dice specifications.

Functional Diagram

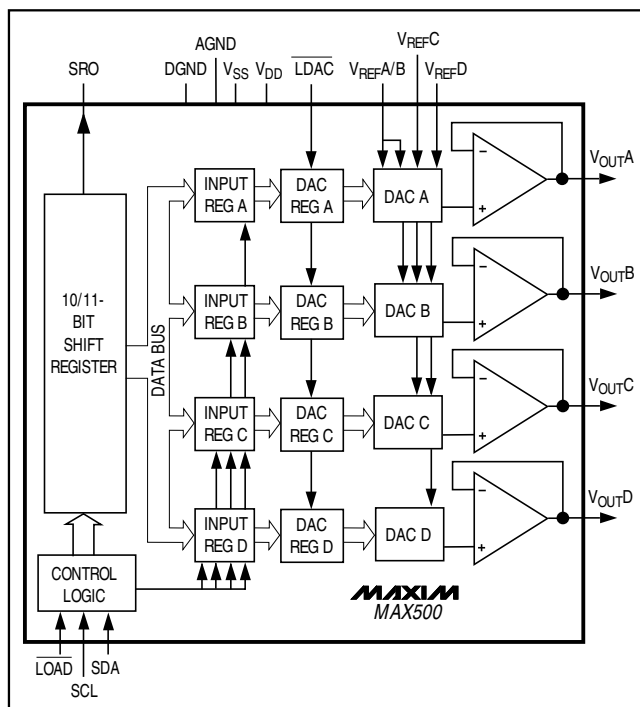

Pin Configurations

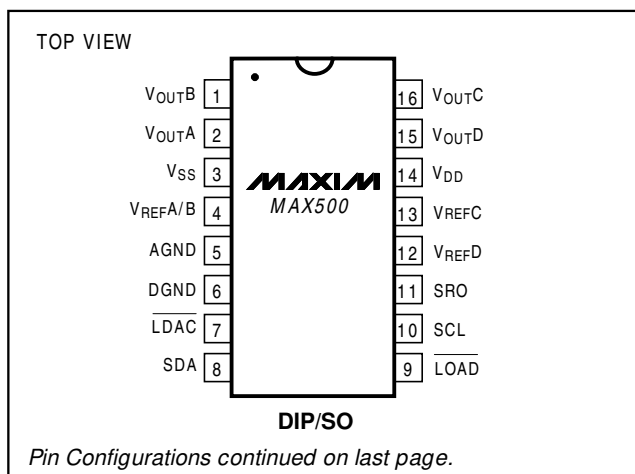

Pin Configurations continued on last page.



CMOS, Quad, Serial-Interface 8-Bit DAC

ABSOLUTE MAXIMUM RATINGS

Power Requirements	Wide SO (derate 9.52mW/°C above +70°C).....762mW
V _{DD} to AGND.....-0.3V, +17V	CERDIP (derate 10.00mW/°C above +70°C).....800mW
V _{DD} to DGND.....-0.3V, +17V	LCC (derate 9.09mW/°C above +70°C).....727mW
V _{SS} to DGND.....-7V, (V _{DD} + 0.3V)	Operating Temperature Ranges
V _{DD} to V _{SS}-0.3V, +24V	MAX500_C.....0°C to +70°C
Digital Input Voltage to DGND.....-0.3V, (V _{DD} + 0.3V)	MAX500_E.....-40°C to +85°C
V _{REF} to AGND.....-0.3V, (V _{DD} + 0.3V)	MAX500_M.....-55°C to +125°C
V _{OUT} to AGND (Note 1).....-0.3V, (V _{DD} + 0.3V)	Storage Temperature Range.....-65°C to +150°C
Power Dissipation (T _A = +70°C)	Lead Temperature (soldering, 10sec).....+300°C
Plastic DIP (derate 10.53mW/°C above +70°C).....842mW	

Note 1: The outputs may be shorted to AGND, provided that the power dissipation of the package is not exceeded. Typical short-circuit current to AGND is 25mA

Stresses beyond those listed under "Absolute Maximum Ratings" may cause permanent damage to the device. These are stress ratings only, and functional operation of the device at these or any other conditions beyond those indicated in the operational sections of the specifications is not implied. Exposure to absolute maximum rating conditions for extended periods may affect device reliability.

ELECTRICAL CHARACTERISTICS—Dual Supplies

(V_{DD} = +11.4V to +16.5V, V_{SS} = -5V ±10%, AGND = DGND = 0V, V_{REF} = +2V to (V_{DD} - 4V), T_A = T_{MIN} to T_{MAX}, unless otherwise noted.)

PARAMETER	SYMBOL	CONDITIONS	MIN	TYP	MAX	UNITS
STATIC PERFORMANCE						
Resolution			8			Bits
Total Unadjusted Error		V _{DD} = 15V ±5%, V _{REF} = 10V	MAX500A		±1	LSB
			MAX500B		±2	
Relative Accuracy		MAX500A MAX500B			±1/2	LSB
					±1	
Differential Nonlinearity		Guaranteed monotonic			±1	LSB
Full-Scale Error		MAX500A MAX500B			±1/2	LSB
					±1	
Full-Scale Tempco		V _{REF} = 10V			±5	ppm/°C
Zero-Code Error		T _A = +25°C	MAX500A		±15	mV
			MAX500B		±20	
		T _A = T _{MIN} to T _{MAX}	MAX500A		±20	
			MAX500B		±30	
Zero-Code Tempco					±30	µV/°C
REFERENCE INPUT						
Reference Input Range			2		V _{DD} - 4	V
Reference Input Resistance		V _{REFC} , V _{REFD}	11			kΩ
		V _{REFA/B}	5.5			
Reference Input Capacitance		T _A = +25°C, code dependent (Note 2)			100	pF
Channel-to-Channel Isolation		T _A = +25°C (Notes 2, 3)	-60			dB
AC Feedthrough		T _A = +25°C (Notes 2, 3)	-70			dB
DIGITAL INPUTS						
Digital Input High Voltage	V _{IH}		2.4		5.5	V
Digital Input Low Voltage	V _{IL}				0.8	V
Digital Output High Voltage	V _{OH}	I _{OUT} = -1mA, SRO only	V _{DD} - 1			V
Digital Output Low Voltage	V _{OL}	I _{OUT} = 1mA, SRO only	0.4			V
Digital Input Leakage Current		(Note 4)	Excluding $\overline{\text{LOAD}}$		±1	µA
			LOAD = 0V		30	
Digital Input Capacitance		T _A = +25°C (Note 2)			8	pF

CMOS, Quad, Serial-Interface 8-Bit DAC

MAX500

ELECTRICAL CHARACTERISTICS—Dual Supplies (continued)

($V_{DD} = +11.4V$ to $+16.5V$, $V_{SS} = -5V \pm 10\%$, $AGND = DGND = 0V$, $V_{REF} = +2V$ to $(V_{DD} - 4V)$, $T_A = T_{MIN}$ to T_{MAX} , unless otherwise noted.)

PARAMETER	SYMBOL	CONDITIONS	MIN	TYP	MAX	UNITS
DYNAMIC PERFORMANCE						
Voltage Output Slew Rate		$T_A = +25^\circ C$ (Note 2)	3	8		V/ μs
V_{OUT} Settling Time		$T_O \pm 1/2LSB$, $V_{REF} = 10V$, $V_{DD} = +15V$, $2k\Omega$ in parallel with $100pF$ load (Note 2)		2.5	4.5	μs
Digital Feedthrough		(Note 5)		50		nV-s
Digital Crosstalk		(Note 5)		50		nV-s
Output Load Resistance		$V_{OUT} = 10V$	2			$k\Omega$
POWER SUPPLIES						
Positive Supply Voltage	V_{DD}	For specified performance	11.4		16.5	V
Positive Supply Current	I_{DD}	Outputs unloaded	$T_A = +25^\circ C$		10	mA
			$T_A = T_{MIN}$ to T_{MAX}		12	
Negative Supply Current	I_{SS}	Outputs unloaded	$T_A = +25^\circ C$		-9	mA
			$T_A = T_{MIN}$ to T_{MAX}		-10	
SWITCHING CHARACTERISTICS ($T_A = +25^\circ C$, Note 6)						
3-Wire Mode						
SDA Valid to SCL Setup	t_{S1}		150			ns
SDA Valid to SCL Hold	t_H		0			ns
SCL High Time	t_1		350			ns
SCL Low Time	t_2		350			ns
SCL Rise Time		(Note 7)			50	μs
SCL Fall Time		(Note 7)			50	μs
\overline{LOAD} Pulse Width	t_{LDW}		150			ns
\overline{LOAD} Delay from SCL	t_{LDS}		150			ns
\overline{LDAC} Pulse Width	t_{LDAC}		150			ns
SRO Output Delay	t_{D1}	$C_{LOAD} = 50pF$			150	ns
2-Wire Mode						
SDA Valid to SCL Hold	t_H		0			ns
SCL High Time	t_1		350			ns
SCL Low Time	t_2		350			ns
SCL Rise Time		(Note 7)			50	μs
SCL Fall Time		(Note 7)			50	μs
\overline{LDAC} Pulse Width	t_{LDAC}		150			ns
SCL Valid to SDA Setup	t_{S1}	Start condition	150			ns
SDA Valid to SCL Setup	t_{S2}	Stop condition	100			ns
SDA Valid to Rising SCL	t_{S3}		125			ns
SRO Output Delay	t_{D1}	$C_{LOAD} = 50pF$			150	ns

CMOS, Quad, Serial-Interface 8-Bit DAC

ELECTRICAL CHARACTERISTICS—Single Supply

($V_{DD} = +15V \pm 5\%$, $V_{SS} = AGND = DGND = 0V$, $V_{REF} = 10V$, $T_A = T_{MIN}$ to T_{MAX} , unless otherwise noted.)

PARAMETER	SYMBOL	CONDITIONS		MIN	TYP	MAX	UNITS
STATIC PERFORMANCE							
Resolution				8			Bits
Total Unadjusted Error		$V_{DD} = 15V \pm 5\%$, $V_{REF} = 10V$	MAX500A			± 1	LSB
			MAX500B			± 2	
Relative Accuracy			MAX500A			$\pm 1/2$	LSB
			MAX500B			± 1	
Differential Nonlinearity		Guaranteed monotonic				± 1	LSB
Full-Scale Error			MAX500A			$\pm 1/2$	LSB
			MAX500B			± 1	
Full-Scale Tempco		$V_{REF} = 10V$				± 5	ppm/ $^{\circ}C$
Zero-Code Error		$T_A = +25^{\circ}C$	MAX500A			± 15	mV
			MAX500B			± 20	
		$T_A = T_{MIN}$ to T_{MAX}	MAX500A			± 20	
			MAX500B			± 30	
Zero-Code Tempco						± 30	$\mu V/^{\circ}C$
REFERENCE INPUT —All specifications are the same as for dual supplies.							
DIGITAL INPUTS —All specifications are the same as for dual supplies.							
DYNAMIC PERFORMANCE —All specifications are the same as for dual supplies.							
POWER SUPPLIES							
Positive Supply Voltage	V_{DD}	For specified performance		14.25		15.75	V
Positive Supply Current	I_{DD}	Outputs unloaded	$T_A = +25^{\circ}C$			10	mA
			$T_A = T_{MIN}$ to T_{MAX}			12	
SWITCHING CHARACTERISTICS —All specifications are the same as for dual supplies.							

Note 2: Guaranteed by design. Not production tested.

Note 3: $T_A = +25^{\circ}C$, $V_{REF} = 10kHz$, 10V peak-to-peak sine wave.

Note 4: LOAD has a weak internal pull-up resistor to V_{DD} .

Note 5: DAC switched from all 1s to all 0s, and all 0s to all 1s code.

Note 6: Sample tested at $+25^{\circ}C$ to ensure compliance.

Note 7: Slow rise and fall times are allowed on the digital inputs to facilitate the use of opto-couplers. Only timing for SCL is given because the other digital inputs should be stable when SCL transitions.

Typical Operating Characteristics

RELATIVE ACCURACY vs. REFERENCE VOLTAGE

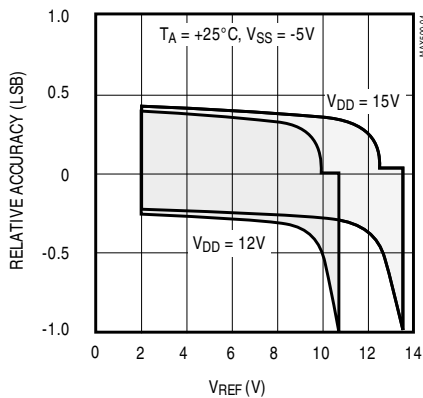

DIFFERENTIAL NONLINEARITY vs. REFERENCE VOLTAGE

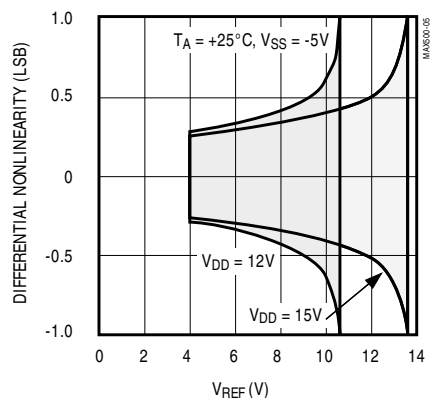

CMOS, Quad, Serial-Interface 8-Bit DAC

MAX500

Typical Operating Characteristics (continued)

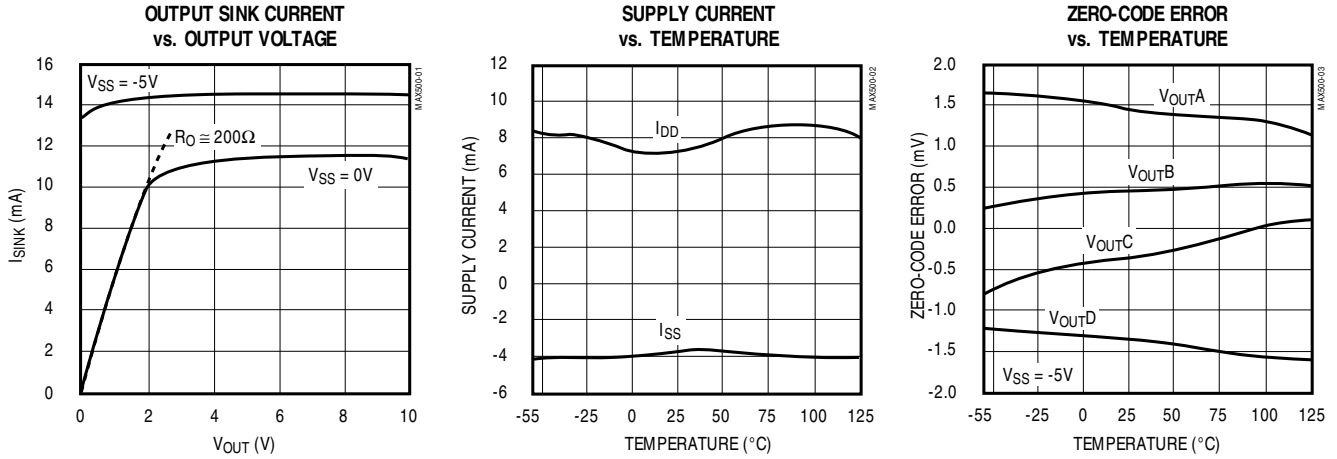

Detailed Description

The MAX500 has four matched voltage-output digital-to-analog converters (DACs). The DACs are “inverted” R-2R ladder networks which convert 8 digital bits into equivalent analog output voltages in proportion to the applied reference voltage(s). Two DACs in the MAX500 have a separate reference input while the other two DACs share one reference input. A simplified circuit diagram of one of the four DACs is provided in Figure 1.

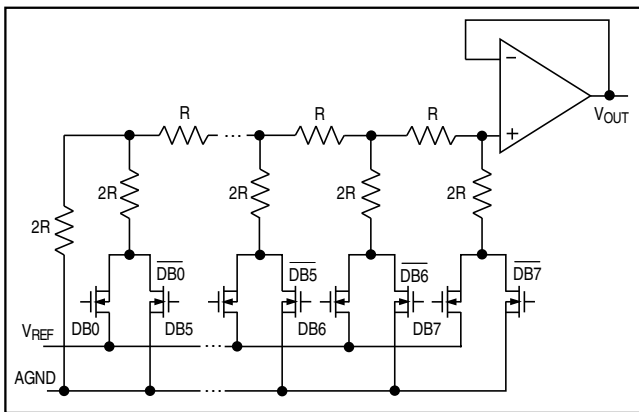

Figure 1. Simplified DAC Circuit Diagram

VREF Input

The voltage at the VREF pins (pins 4, 12, and 13) sets the full-scale output of the DAC. The input impedance

of the VREF inputs is code dependent. The lowest value, approximately 11kΩ (5.5kΩ for VREFA/B), occurs when the input code is 01010101. The maximum value of infinity occurs when the input code is 00000000. Because the input resistance at VREF is code dependent, the DAC’s reference sources should have an output impedance of no more than 20Ω (no more than 10Ω for VREFA/B). The input capacitance at VREF is also code dependent and typically varies from 15pF to 35pF (30pF to 70pF for VREFA/B). VOUTA, VOUTB, VOUTC, and VOUTD can be represented by a digitally programmable voltage source as:

$$V_{OUT} = N_b \times V_{REF} / 256$$

where N_b is the numeric value of the DAC’s binary input code.

Output Buffer Amplifiers

All voltage outputs are internally buffered by precision unity-gain followers, which slew at greater than 3V/μs. When driving 2kΩ in parallel with 100pF with a full-scale transition (0V to +10V or +10V to 0V), the output settles to ±1/2LSB in less than 4μs. The buffers will also drive 2kΩ in parallel with 500pF to 10V levels without oscillation. Typical dynamic response and settling performance of the MAX500 is shown in Figures 2 and 3.

A simplified circuit diagram of an output buffer is shown in Figure 4. Input common-mode range to AGND is provided by a PMOS input structure. The output circuitry incorporates a pull-down circuit to actively drive VOUT to within +15mV of the negative supply (VSS). The buffer circuitry allows each DAC output to

CMOS, Quad, Serial-Interface 8-Bit DAC

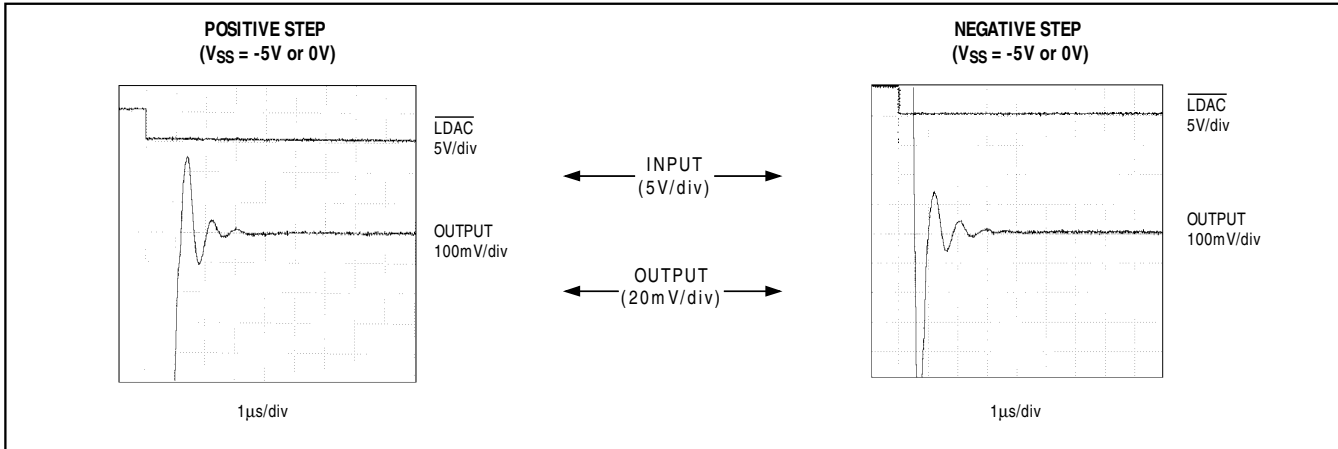

Figure 2. Positive and Negative Settling Times

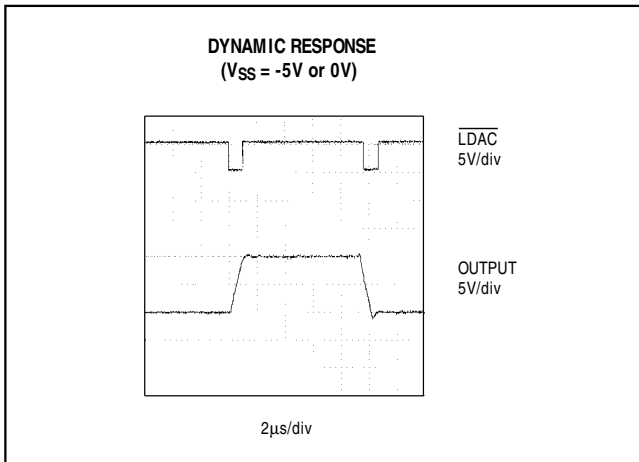

Figure 3. Dynamic Response

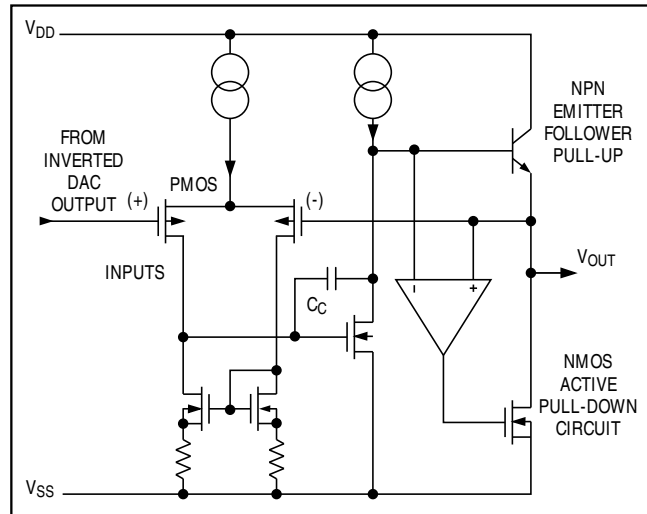

Figure 4. Simplified Output Buffer Circuit

sink, as well as source up to 5mA. This is especially important in single-supply applications, where V_{SS} is connected to AGND, so that the zero error is kept at or under 1/2LSB ($V_{REF} = +10V$). A plot of the Output Sink Current vs. Output Voltage is shown in the *Typical Operating Characteristics* section.

Digital Inputs and Interface Logic

The digital inputs are compatible with both TTL and 5V CMOS logic; however, the power-supply current (I_{DD}) is somewhat dependent on the input logic level. Supply current is specified for TTL input levels (worst case) but is reduced (by about 150µA) when the logic inputs are driven near DGND or 4V above DGND.

Do not drive the digital inputs directly from CMOS logic running from a power supply exceeding 5V. When driv-

ing SCL through an opto-isolator, use a Schmitt trigger to ensure fast SCL rise and fall times.

The MAX500 allows the user to choose between a 3-wire serial interface and a 2-wire serial interface. The choice between the 2-wire and the 3-wire interface is set by the \overline{LOAD} signal. If the \overline{LOAD} is allowed to float (it has a weak internal pull-up resistor to V_{DD}), the 2-wire interface is selected. If the \overline{LOAD} signal is kept to a TTL-logic high level, the 3-wire interface is selected.

3-Wire Interface

The 3-wire interface uses the classic Serial Data (SDA), Serial Clock (SCL), and \overline{LOAD} signals that are used in standard shift registers. The data is clocked in on the falling edge of SCL until all 10 bits (8 data bits and 2 address bits) are entered into the shift register.

CMOS, Quad, Serial-Interface 8-Bit DAC

MAX500

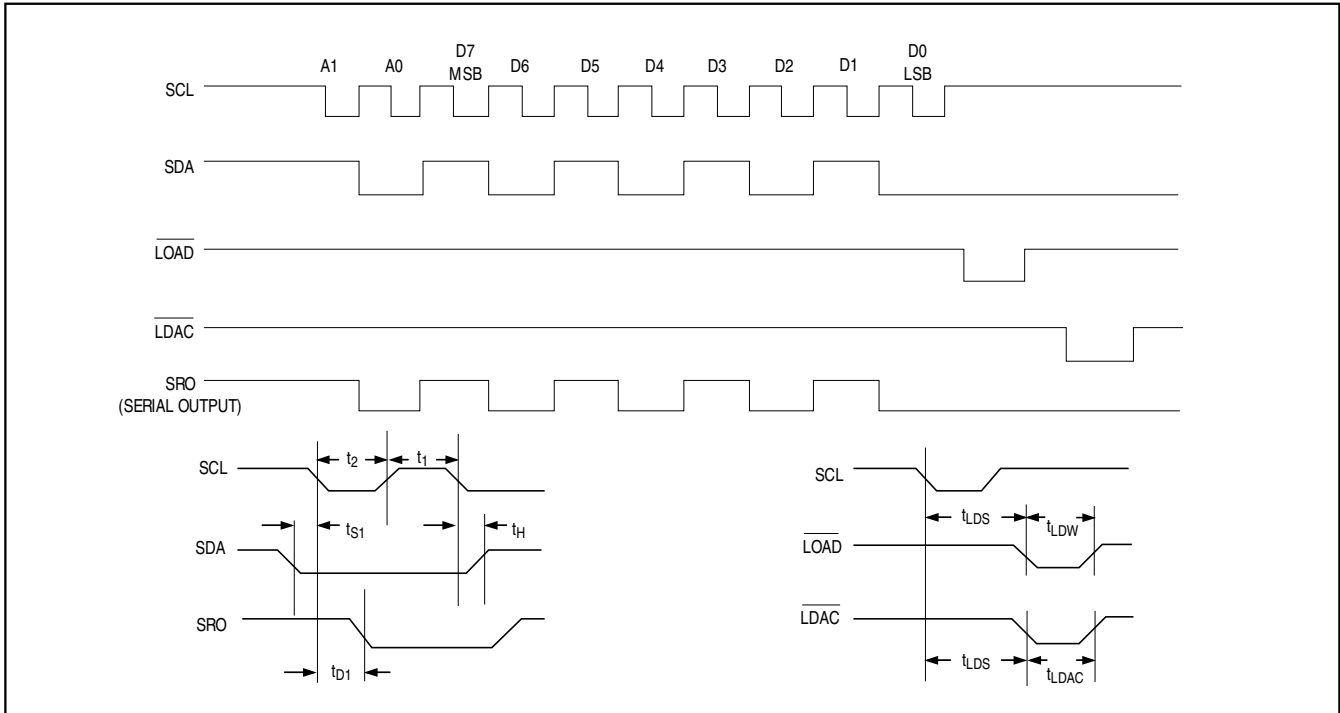

Figure 5. 3-Wire Mode

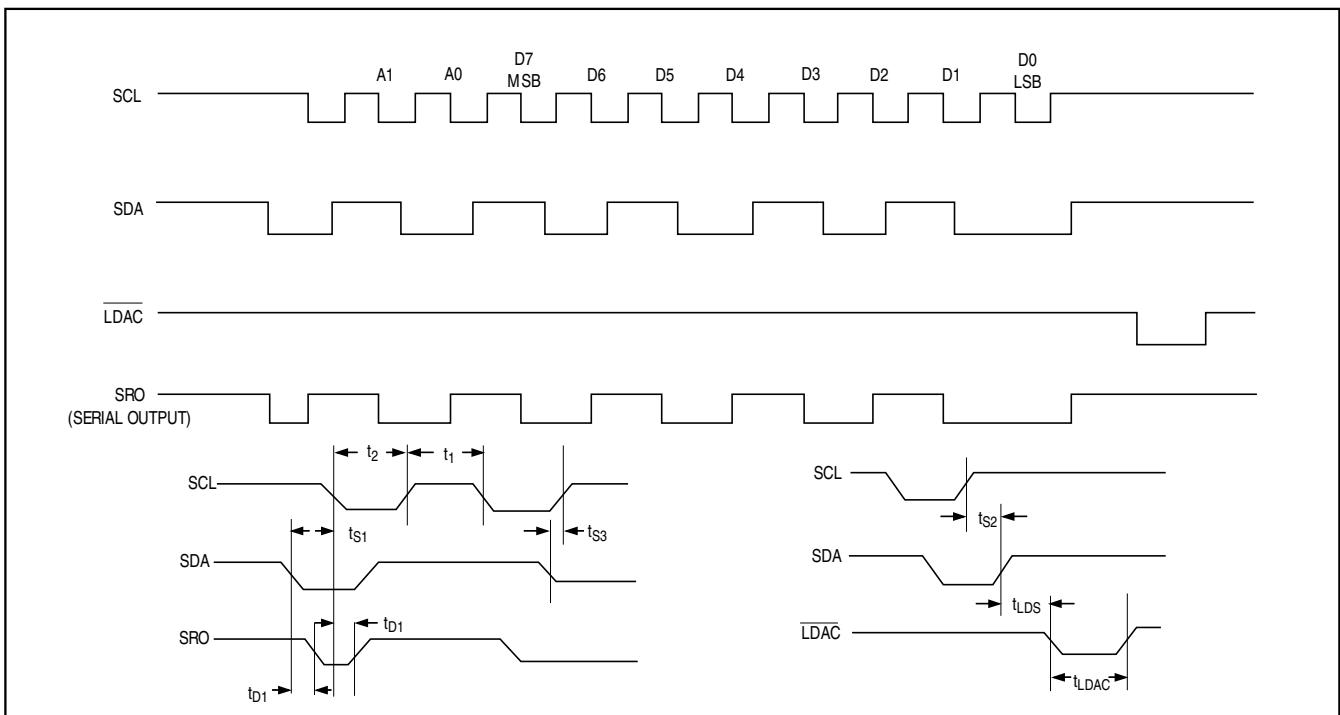

Figure 6. 2-Wire Mode

CMOS, Quad, Serial-Interface 8-Bit DAC

A low level on $\overline{\text{LOAD}}$ line initiates the transfer of data from the shift register to the addressed input register. The data can stay in this register until all four of the input registers are updated. Then all of the DAC registers can be simultaneously updated using the $\overline{\text{LDAC}}$ (load DAC) signal. When $\overline{\text{LDAC}}$ is low, the input register's data is loaded into the DAC registers (see Figure 5 for timing diagram). This mode is cascadable by connecting Serial Output (SRO) to the second chip's SDA pin. The delay of the SRO pin from SCL does not cause setup/hold time violations, no matter how many MAX500s are cascaded. Restrict the voltage at $\overline{\text{LDAC}}$ and $\overline{\text{LOAD}}$ to +5.5V for a logic high.

2-Wire Interface

The 2-wire interface uses SDA and SCL only. $\overline{\text{LOAD}}$ must be floating or tied to V_{DD} . Each data frame (8 data bits and 2 address bits) is synchronized by a timing relationship between SDA and SCL (see Figure 6 for the timing diagram). Both SDA and SCL should normally be high when inactive. A falling edge of SDA (while SCL is high) followed by a falling edge of SCL (while SDA is low) is the start condition. This always loads a 0 into the first bit of the shift register. The shift register is extended to 11 bits so this "data" will not affect the input register information. The timing now follows the 3-wire interface, except the SDA line is not allowed to change when SCL is high (this prevents the MAX500 from retriggering its start condition). After the last data bit is entered, the SDA line should go low (while the SCL line is low), then the SCL line should rise followed by the SDA line rising. This is defined as the stop condition, or end of frame.

Cascading the 2-wire interface can be done, but the user must be careful of both timing and formatting. Timing must take into account the intrinsic delay of the SRO pin from the internally generated start/stop conditions. The t_{S2} value should be increased by n times t_{D1} (where n = number of cascaded MAX500s). The t_{LDS} value should also be increased by n times t_{D1} . No other timing parameters need to be modified. A more serious concern is one of formatting. Generally, since each frame has a start/stop condition, each chip that has data cascaded through it will accept that data as if it were its own data. Therefore, to circumvent this limitation, the user should not generate a stop bit until all DACs have been loaded. For example, if there are three MAX500s cascaded in the 2-wire mode, the data transfer should begin with a start condition, followed by 10 data bits, a zero bit, 10 data bits, a zero bit, 10 data bits, and then a stop condition. This will prevent each MAX500 from decoding the middle data for itself.

The data is entered into the shift register in the following order:

A1 A0 D7 D6 D5 D4 D3 D2 D1 D0
(First) (MSB) (Last)

where address bits A1 and A0 select which DAC register receives data from the internal shift register. Table 1 lists the channel addresses. D7 (MSB) through D0 is the data byte.

Since $\overline{\text{LDAC}}$ is asynchronous with respect to SCL, SDA, and $\overline{\text{LOAD}}$, care must be taken to assure that incorrect data is not latched through to the DAC registers. If the 3-wire serial interface is used, $\overline{\text{LDAC}}$ can be either tied low permanently or tied to $\overline{\text{LOAD}}$ as long as t_{LDS} is always maintained. However, if the 2-wire interface is used, $\overline{\text{LDAC}}$ should not fall before the stop condition is internally detected. (This is the reason for the t_{LDS} delay of $\overline{\text{LDAC}}$ after the last rising edge of SDA.)

Table 1. DAC Addressing

A1	A0	SELECTED INPUT REGISTER
L	L	DAC A Input Register
L	H	DAC B Input Register
H	L	DAC C Input Register
H	H	DAC D Input Register

Table 2. Logic Input Truth Table

SCL	SDA	$\overline{\text{LOAD}}$	$\overline{\text{LDAC}}$	FUNCTION
F	Data	V_{DD}	H	Latching data into shift register (2W)
H	Data	V_{DD}	H	Data should not be changing (2W)
L	X	V_{DD}	H	Data is allowed to change (2W)
F	Data	M	H	Latching data into shift register (3W)
H	X	M	H	Data is allowed to change (3W)
L	X	M	H	Data is allowed to change (3W)
H	X	L	H	Loads input register from shift register (3W)
H	X	L	L	DAC register reflects data held in their respective input registers

Notes:

H = Logic High 2W = 2-Wire
L = Logic Low 3W = 3-Wire
M = TTL Logic High F = Falling Edge
X = Don't Care

CMOS, Quad, Serial-Interface 8-Bit DAC

The SRO output swings from V_{DD} to DGND. Cascading to other MAX500s poses no problem. If SRO is used to drive a TTL-compatible input, use a clamp diode between TTL +5V and V_{DD} and the current-limiting resistor to prevent potential latchup problems with the 5V supply.

Table 2 shows the truth table for SDA, SCL, \overline{LOAD} , and \overline{LDAC} operation. Figures 5 and 6 show the timing diagrams for the MAX500.

Applications Information

Power-Supply and Reference Operating Ranges

The MAX500 is fully specified to operate with V_{DD} between $+12V \pm 5\%$ and $+15V \pm 10\%$ ($+11.4V$ to $+16.5V$), and with V_{SS} from $0V$ to $-5.5V$. 8-bit performance is also guaranteed for single-supply operation ($V_{SS} = 0V$), however, zero-code error is reduced when V_{SS} is $-5V$ (see *Output Buffer Amplifiers* section).

For an adequate DAC and buffer operating range, the V_{REF} voltage must always be at least 4V below V_{DD} . The MAX500 is specified to operate with a reference input range of $+2V$ to $V_{DD} - 4V$.

Ground Management

Digital or AC transient signals between AGND and DGND will create noise at the analog outputs. It is recommended that AGND and DGND be tied together at the DAC and that this point be tied to the highest quality ground available. If separate ground buses are used, then two clamp diodes (1N914 or equivalent) should be connected between AGND and DGND to keep the two

ground buses within one diode drop of each other. To avoid parasitic device turn-on, AGND must not be allowed to be more negative than DGND. DGND should be used as supply ground for bypassing purposes.

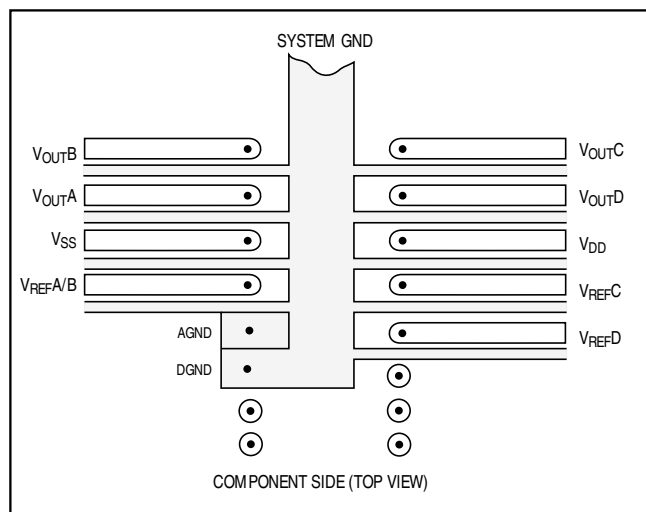

Figure 7. Suggested MAX500 PC Board Layout for Minimizing Crosstalk

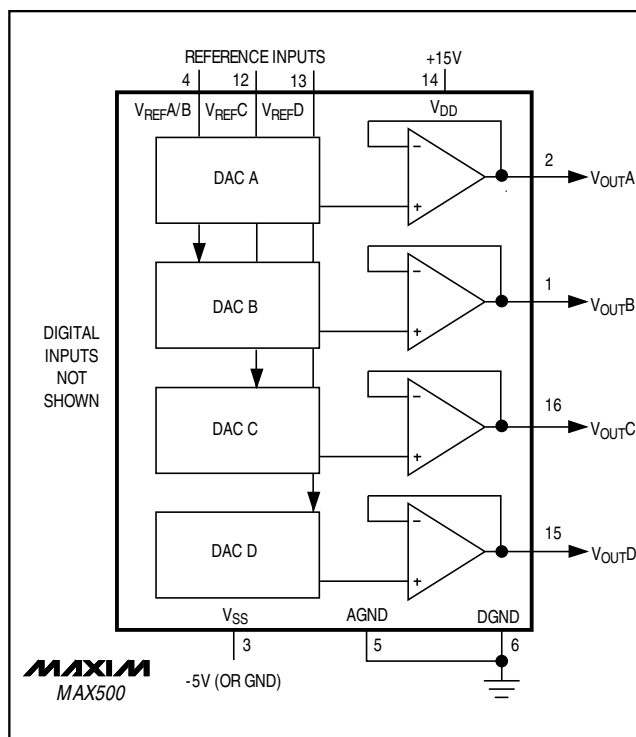

Figure 8. MAX500 Unipolar Output Circuit

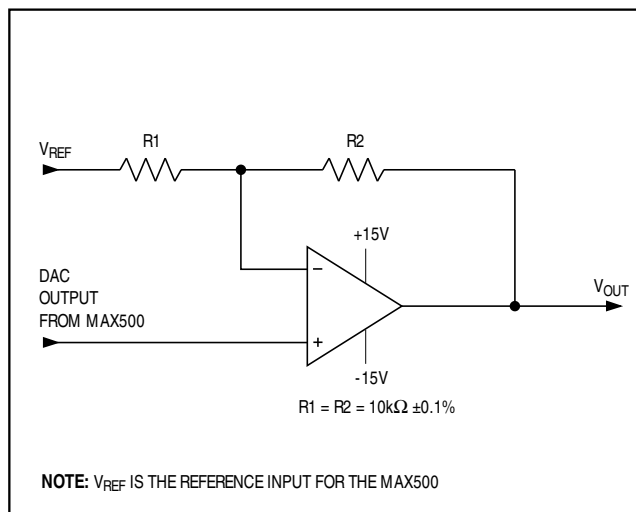

Figure 9. Bipolar Output Circuit

CMOS, Quad, Serial-Interface 8-Bit DAC

Table 3. Unipolar Code Table

DAC CONTENTS		ANALOG OUTPUT
MSB	LSB	
1 1 1 1	1 1 1 1	$+V_{REF} \left(\frac{255}{256} \right)$
1 0 0 0	0 0 0 1	$+V_{REF} \left(\frac{129}{256} \right)$
1 0 0 0	0 0 0 0	$+V_{REF} \left(\frac{128}{256} \right) = + \frac{V_{REF}}{2}$
0 1 1 1	1 1 1 1	$+V_{REF} \left(\frac{127}{256} \right)$
0 0 0 0	0 0 0 1	$+V_{REF} \left(\frac{1}{256} \right)$
0 0 0 0	0 0 0 0	0V

Note: 1LSB = $(V_{REF}) (2^{-8}) = +V_{REF} \left(\frac{1}{256} \right)$

Careful PC board ground layout techniques should be used to minimize crosstalk between DAC outputs, the reference input(s), and the digital inputs. This is particularly important if the reference is driven from an AC source. Figure 7 shows suggested PC board layouts for minimizing crosstalk.

Unipolar Output

In unipolar operation, the output voltages and the reference input(s) are the same polarity. The unipolar circuit configuration is shown in Figure 8 for the MAX500. The device can be operated from a single supply with a slight increase in zero error (see *Output Buffer Amplifiers* section). To avoid parasitic device turn-on, the voltage at V_{REF} must always be positive with respect to AGND. The unipolar code table is given in Table 3.

Bipolar Output

Each DAC output may be configured for bipolar operation using the circuit in Figure 9. One op amp and two resistors are required per channel. With $R1 = R2$:

$$V_{OUT} = V_{REF} (2D_A - 1)$$

where D_A is a fractional representation of the digital word in Register A.

Table 4 shows the digital code versus output voltage for the circuit in Figure 9.

Table 4. Bipolar Code Table

DAC CONTENTS		ANALOG OUTPUT
MSB	LSB	
1 1 1 1	1 1 1 1	$+V_{REF} \left(\frac{127}{128} \right)$
1 0 0 0	0 0 0 1	$+V_{REF} \left(\frac{1}{128} \right)$
1 0 0 0	0 0 0 0	0V
0 1 1 1	1 1 1 1	$-V_{REF} \left(\frac{1}{128} \right)$
0 0 0 0	0 0 0 1	$-V_{REF} \left(\frac{127}{128} \right)$
0 0 0 0	0 0 0 0	$-V_{REF} \left(\frac{128}{128} \right) = -V_{REF}$

Note: 1LSB = $(V_{REF}) (2^{-8}) = +V_{REF} \left(\frac{1}{256} \right)$

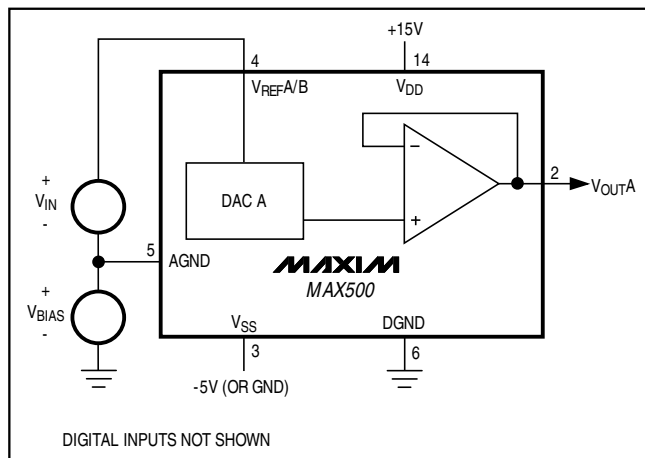

Figure 10. AGND Bias Circuit

Offsetting AGND

AGND can be biased above DGND to provide an arbitrary nonzero output voltage for a "zero" input code. This is shown in Figure 10. The output voltage at V_{OUTA} is:

$$V_{OUTA} = V_{BIAS} + D_A V_{IN}$$

where D_A is a fractional representation of the digital input word. Since AGND is common to all four DACs, all outputs will be offset by V_{BIAS} in the same manner. Since AGND current is a function of the four DAC codes, it should be driven by a low-impedance source. V_{BIAS} must be positive.

CMOS, Quad, Serial-Interface 8-Bit DAC

MAX500

Using an AC Reference

In applications where V_{REF} has AC signal components, the MAX500 has multiplying capability within the limits of the V_{REF} input range specifications. Figure 11 shows a technique for applying a sine-wave signal to the reference input, where the AC signal is biased up before being applied to V_{REF} . Output distortion is typically less than 0.1% with input frequencies up to 50kHz, and the typical -3dB frequency is 700kHz. Note that V_{REF} must never be more negative than AGND.

Generating V_{SS}

The performance of the MAX500 is specified for both dual and single-supply ($V_{SS} = 0V$) operation. When the improved performance of dual-supply operation is desired, but only a single supply is available, a -5V V_{SS} supply can be generated using an ICL7660 in one of the circuits of Figure 12.

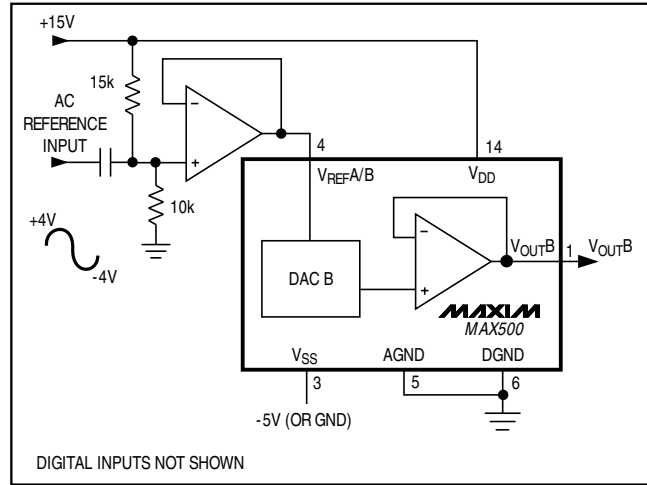

Figure 11. AC Reference Input Circuit

Digital Interface Applications

Figures 13 through 16 show examples of interfacing the MAX500 to most popular microprocessors.

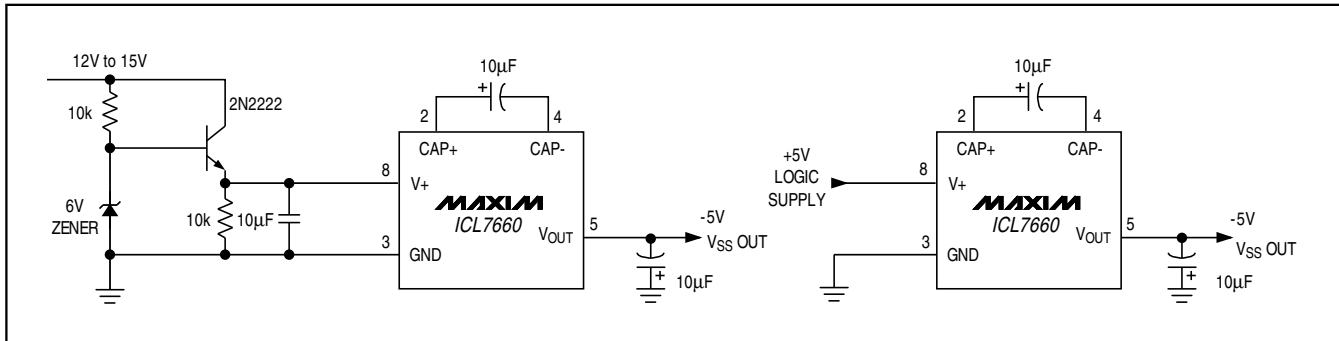

Figure 12. Generating -5V for V_{SS}

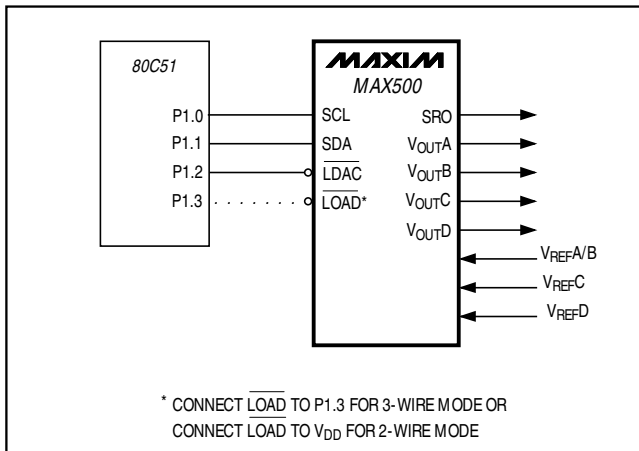

Figure 13. 80C51 Interface

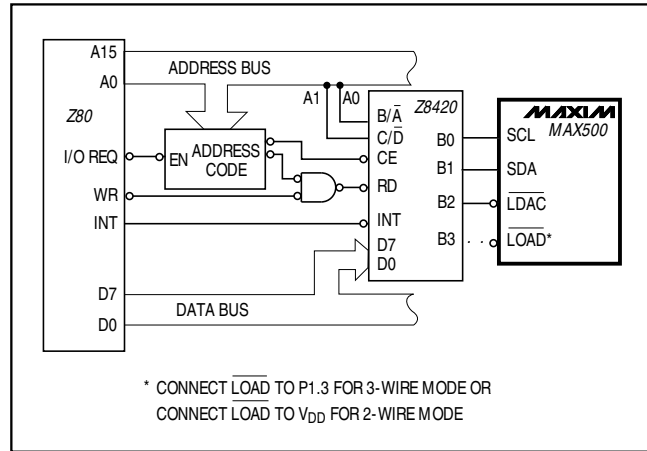

Figure 14. Z-80 with Z8420 PIO Interface

CMOS, Quad, Serial-Interface, 8-Bit DAC

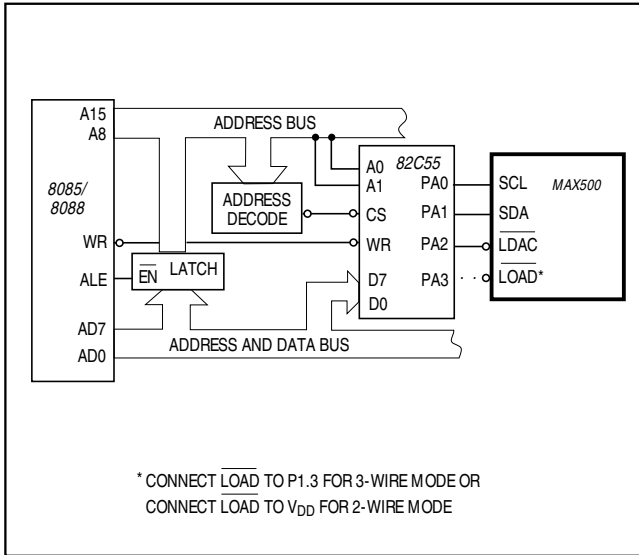

Figure 15. 8085/8088 with Programmable Peripheral Interface

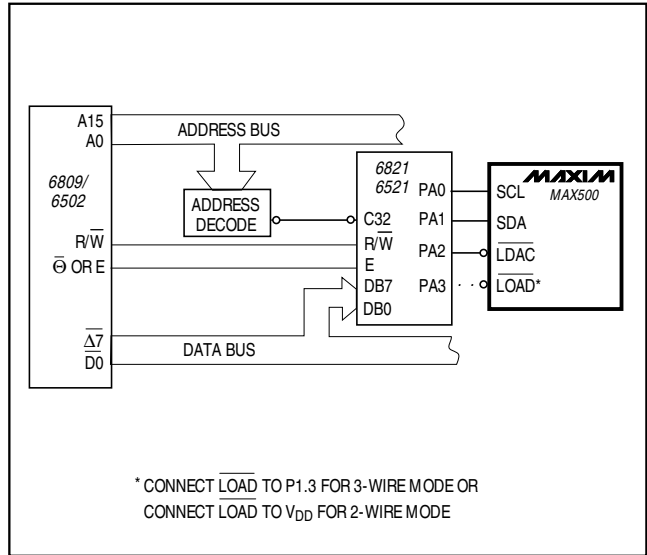
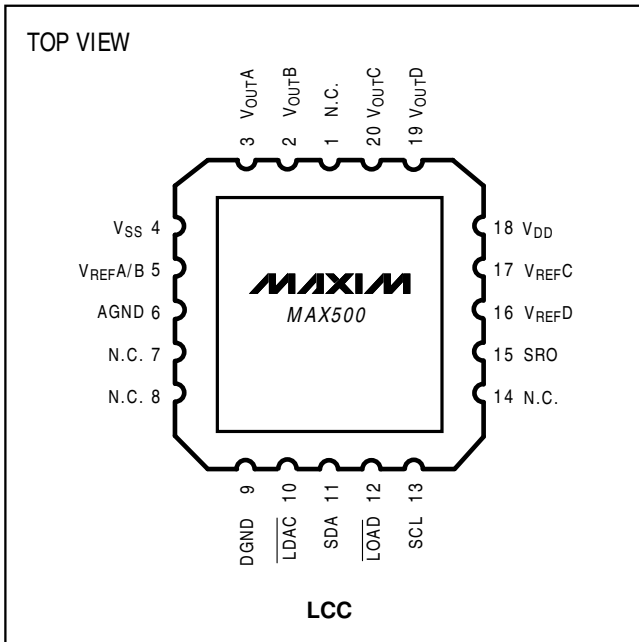
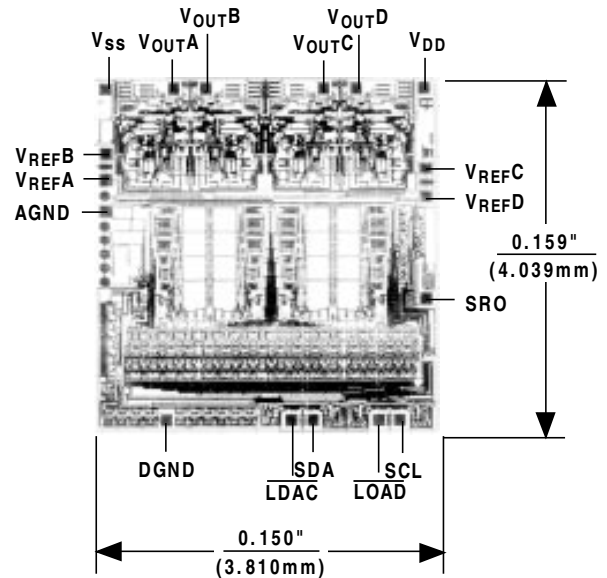

Figure 16. 6809/6502 Interface

Pin Configurations (continued)



Chip Topography



Maxim cannot assume responsibility for use of any circuitry other than circuitry entirely embodied in a Maxim product. No circuit patent licenses are implied. Maxim reserves the right to change the circuitry and specifications without notice at any time.

12 Maxim Integrated Products, 120 San Gabriel Drive, Sunnyvale, CA 94086 (408) 737-7600