



Chipsmall Limited consists of a professional team with an average of over 10 year of expertise in the distribution of electronic components. Based in Hongkong, we have already established firm and mutual-benefit business relationships with customers from,Europe,America and south Asia,supplying obsolete and hard-to-find components to meet their specific needs.

With the principle of “Quality Parts,Customers Priority,Honest Operation,and Considerate Service”,our business mainly focus on the distribution of electronic components. Line cards we deal with include Microchip,ALPS,ROHM,Xilinx,Pulse,ON,Everlight and Freescale. Main products comprise IC,Modules,Potentiometer,IC Socket,Relay,Connector.Our parts cover such applications as commercial,industrial, and automotives areas.

We are looking forward to setting up business relationship with you and hope to provide you with the best service and solution. Let us make a better world for our industry!



Contact us

Tel: +86-755-8981 8866 Fax: +86-755-8427 6832

Email & Skype: info@chipsmall.com Web: www.chipsmall.com

Address: A1208, Overseas Decoration Building, #122 Zhenhua RD., Futian, Shenzhen, China





Voltage-Output, 12-Bit Multiplying DACs

MAX501/MAX502

General Description

The MAX501/MAX502 are 12-bit, 4-quadrant, voltage-output, multiplying digital-to-analog converters (DACs) with an output amplifier. Thin-film resistors, laser trimmed at the wafer level, maintain accuracy over the full operating temperature range.

The MAX501/MAX502 have buffered latches that are easily interfaced with microprocessors. Data is transferred into the input register in either a right-justified 8+4-bit format (MAX501) or with a 12-bit-wide data path (MAX502). In the MAX501, an LDAC signal transfers data from the input register to the DAC register. In the MAX502, the input registers are controlled by standard CHIP SELECT (CS) and WRITE (WR) signals. For stand-alone operation, the CS and WR inputs are grounded, making all latches transparent. All logic inputs are level triggered and compatible with TTL and +5V CMOS logic levels.

The internally compensated, low-input offset-voltage output amplifier provides an output voltage from +10V to -10V while sourcing and sinking up to 5mA.

Applications

- Digital Attenuators
- Programmable-Gain Amplifiers
- Servo Controls
- Digital to 4mA-to-20mA Converters
- Automatic Test Equipment
- Programmable Power Supplies

Functional Diagram

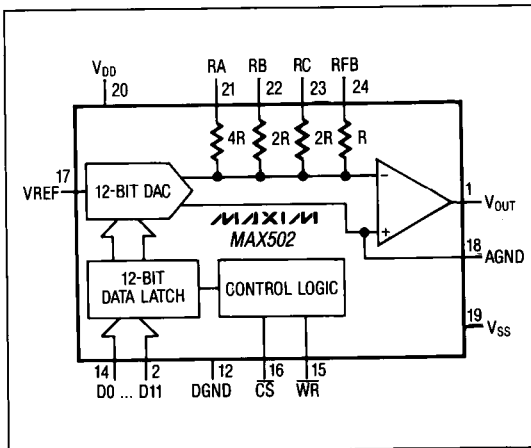

Features

- ◆ 12-Bit Voltage Output DAC
- ◆ ±10V and 5mA Output Drive
- ◆ Monotonic Over Temperature
- ◆ Four Range-Scaling Resistors
- ◆ 8+4 (MAX501) and 12-Bit (MAX502) Interface
- ◆ 24-Pin DIP and Wide SO Packages

Ordering Information

PART	TEMP. RANGE	PIN-PACKAGE	ERROR (LSBs)
MAX501ACNG	0°C to +70°C	24 Narrow Plastic DIP	±1/2
MAX501BCNG	0°C to +70°C	24 Narrow Plastic DIP	±3/4
MAX501ACWG	0°C to +70°C	24 Wide SO	±1/2
MAX501BCWG	0°C to +70°C	24 Wide SO	±3/4
MAX501BC/D	0°C to +70°C	Dice*	±3/4
MAX501AENG	-40°C to +85°C	24 Narrow Plastic DIP	±1/2
MAX501BENG	-40°C to +85°C	24 Narrow Plastic DIP	±3/4
MAX501AEWG	-40°C to +85°C	24 Wide SO	±1/2
MAX501BEWG	-40°C to +85°C	24 Wide SO	±3/4
MAX501AMRG	-55°C to +125°C	24 Narrow CERDIP**	±1/2
MAX501BMRG	-55°C to +125°C	24 Narrow CERDIP**	±3/4

Ordering information continued on last page.
 * Contact factory for dice specifications.
 ** Contact factory for availability and processing to MIL-STD-883.

Pin Configurations

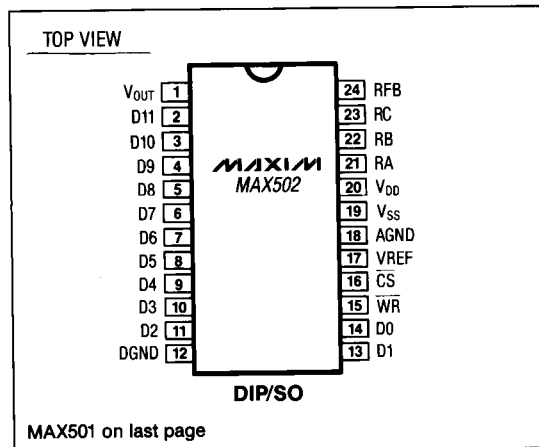

MAX501 on last page



Voltage-Output, 12-Bit Multiplying DACs

MAX501/MAX502

ABSOLUTE MAXIMUM RATINGS

V _{DD} to DGND	-0.3V, +17V	Digital Input Voltage to DGND	-0.3V, V _{DD}
V _{SS} to DGND	+0.3V, -17V	Continuous Power Dissipation (any package)		
VREF to AGND	±25V	to +75°C	650mW
RFB to AGND	±25V	derate above +75°C	10mW/°C
RA to AGND	±25V	Operating Temperature Ranges:		
RB to AGND	±25V	MAX501_C_, MAX502_C_	0°C to +70°C
RC to AGND	±25V	MAX501_E_, MAX502_E_	-40°C to +85°C
V _{OUT} to AGND (Note 1)	V _{DD} +0.3V, V _{SS} -0.3V	MAX501_M_, MAX502_M_	-55°C to +125°C
V _{DD} to AGND	-0.3V, +17V	Storage Temperature Range	-65°C to +150°C
AGND to DGND	-0.3V, V _{DD}	Lead Temperature (soldering, 10 sec)	+300°C

Note 1: V_{OUT} may be shorted to AGND, V_{DD}, or V_{SS} if the power dissipation of the package is not exceeded.

Stresses beyond those under "Absolute Maximum Ratings" may cause permanent damage to the device. These are stress ratings only, and functional operation of the device at these or any other conditions beyond those indicated in the operational sections of the specification is not implied. Exposure to absolute maximum rating conditions for extended periods may affect device reliability.

ELECTRICAL CHARACTERISTICS

Dual Supply (V_{DD} = +11.4V to +15.75V, V_{SS} = -11.4V to -15.75V, VREF = +10V, AGND = DGND = 0V, R_L = 2kΩ, C_L = 100pF, all grades, T_A = T_{MIN} to T_{MAX}, unless otherwise noted.) (Note 2)

PARAMETER	SYMBOL	CONDITIONS		MIN	TYP	MAX	UNITS	
STATIC PERFORMANCE								
Resolution	N			12			Bits	
Relative Accuracy	INL	T _A = +25°C	MAX501/502A			±1/2	LSB	
			MAX501/502B			±3/4		
		T _A = T _{MIN} to T _{MAX}	MAX501/502A			±3/4		
			MAX501/502B			±1		
Differential Nonlinearity	DNL					±1	LSB	
Zero-Code Offset Error		T _A = +25°C				±1	mV	
		T _A = T _{MIN} to T _{MAX}	MAX501/502_C/E			±2		
			MAX501/502_M			±3		
Offset Temperature Coefficient	ΔV _{OS} /ΔTemp					±5	μV/°C	
Gain Error		RFB, V _{OUT} connected				±3	LSB	
		RC or RB connected to V _{OUT} , VREF = 5V				±4½		
		RA, V _{OUT} connected, VREF = 2.5V				±6		
Gain Temperature Coefficient	ΔGain/ΔTemp					±1	ppm/°C	
Reference Input Resistance		RFB			8	12	16	kΩ
Application Resistor Ratio Matching		RA to RB to RC match				0.5		%

Voltage-Output, 12-Bit Multiplying DACs

MAX501/MAX502

ELECTRICAL CHARACTERISTICS (continued)

Dual Supply ($V_{DD} = +11.4V$ to $+15.75V$, $V_{SS} = -11.4V$ to $-15.75V$, $V_{REF} = +10V$, $AGND = DGND = 0V$, $R_L = 2k\Omega$, $C_L = 100pF$, all grades, $T_A = T_{MIN}$ to T_{MAX} , unless otherwise noted.) (Note 2)

PARAMETER	SYMBOL	CONDITIONS	MIN	TYP	MAX	UNITS
DIGITAL INPUTS						
Input Current	I_{IN}	$V_{IN} = 0V$ and V_{DD}	$T_A = +25^\circ C$		± 1	μA
			$T_A = T_{MIN}$ to T_{MAX}		± 10	
Input Low Voltage	V_{IL}				0.8	V
Input High Voltage	V_{IH}		2.4			V
Input Capacitance	C_{IN}			7		pF
POWER SUPPLIES						
Supply Voltage	V_{DD}		11.40		15.75	V
	V_{SS}		-11.40		-15.75	
Supply Current	I_{DD}	V_{OUT} unloaded		10		mA
	I_{SS}	V_{OUT} unloaded		4		
Power-Supply Rejection	PSR	$\Delta Gain/\Delta V_{DD}$	$V_{REF} = -10V$ $V_{DD} = 15V \pm 5\%$		± 0.02	%/%
			$V_{REF} = -8.9V$ $V_{DD} = 12V \pm 5\%$			
		$\Delta Gain/\Delta V_{SS}$	$V_{REF} = 10V$ $V_{SS} = -15V \pm 5\%$		± 0.02	
			$V_{REF} = 8.9V$ $V_{SS} = -12V \pm 5\%$			
DYNAMIC PERFORMANCE (Note 3)						
Output-Voltage Settling Time	t_S	To $\pm 0.01\%$ of full scale		5		μs
Slew Rate	SR			5		V/ μs
DAC Glitch Impulse		Major carry transition		450		nV-s
Multiplying Feedthrough Error		$V_{REF} = \pm 10V$ at 10kHz, DAC = all 0s		5		mV _{P-P}
Unity-Gain Small-Signal Bandwidth				3		MHz
Full-Power Bandwidth				250		kHz
Total Harmonic Distortion	THD	$V_{REF} = 6V_{RMS}$ at 1kHz		-90		dB
OUTPUT CHARACTERISTICS						
Open-Loop Gain	A_{VO}	RFB not connected, $V_{OUT} = \pm 10V$, $R_L = 2k\Omega$	90			dB
Output Resistance	R_O			0.2		Ω
Short-Circuit Current		$T_A = +25^\circ C$		20		mA
Output Noise Voltage		0.1Hz to 10Hz, $T_A = +25^\circ C$		2		μV_{RMS}
		$f = 1kHz$, $T_A = +25^\circ C$		25		nV/ \sqrt{Hz}

Voltage-Output, 12-Bit Multiplying DACs

MAX501/MAX502

TIMING CHARACTERISTICS (See Figures 1a, 1b)

Dual Supply ($V_{DD} = +11.4V$ to $+15.75V$, $V_{SS} = -11.4V$ to $-15.75V$, $V_{REF} = +10V$, $AGND = DGND = 0V$, $R_L = 2k\Omega$, $C_L = 100pF$, all grades, $T_A = T_{MIN}$ to T_{MAX} , unless otherwise noted.) (Note 2)

PARAMETER	SYMBOL	CONDITIONS	MIN	TYP	MAX	UNITS	
MAX501							
Chip Select to Write-Setup Time	t _{CS}		0			ns	
Write Pulse Width	t _{WR}	T _A = +25°C	55			ns	
		T _A = T _{MIN} to T _{MAX}	70				
Data-Setup Time	t _{DS}	MAX501_C/E	50			ns	
		MAX501_M	60				
Data-Hold Time	t _{DH}		10	0		ns	
LDAC Pulse Width	t _{LDAC}		70			ns	
CLR Pulse Width	t _{CLR}		70			ns	
SET Pulse Width	t _{SET}		200			ns	
MAX502							
Chip Select to Write-Setup Time	t _{CS}		0			ns	
Write Pulse Width	t _{WR}	T _A = +25°C	40			ns	
		T _A = T _{MIN} to T _{MAX}	MAX502_C/E	50			
			MAX502_M	60			
Data-Setup Time	t _{DS}	MAX502_C/E	50			ns	
		MAX502_M	60				
Data-Hold Time	t _{DH}		10	0		ns	

Note 2: V_{OUT} must be less than V_{DD} - 2.5V and greater than V_{SS} + 2.5V to ensure correct operation. Performance at supplies other than V_{DD} = +15V and V_{SS} = -15V is guaranteed by PSRR tests. Leave unused feedback resistors floating.

Note 3: Dynamic Performance and Output Characteristics are included for design guidance and are not subject to test.

Voltage-Output, 12-Bit Multiplying DACs

Typical Operating Characteristics

MAX501/MAX502

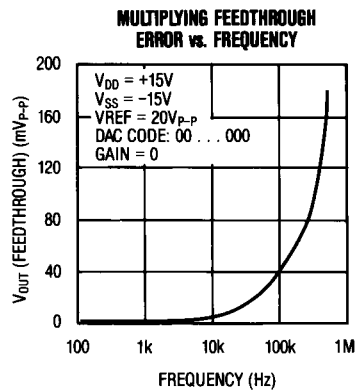
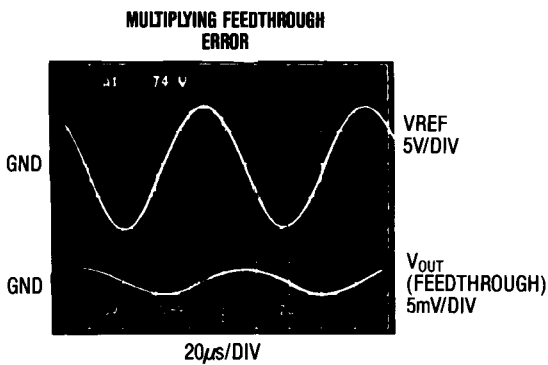
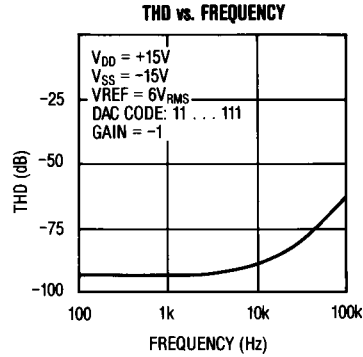
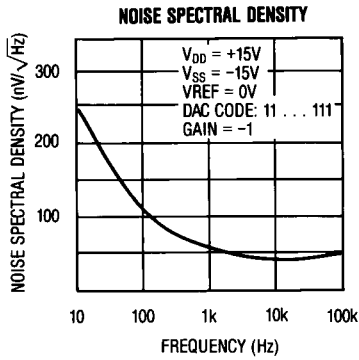
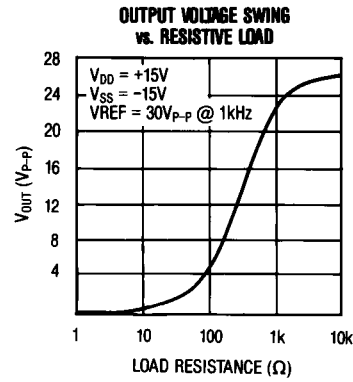
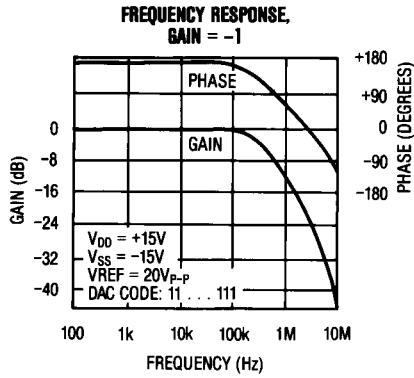

Voltage-Output, 12-Bit Multiplying DACs

MAX501/MAX502

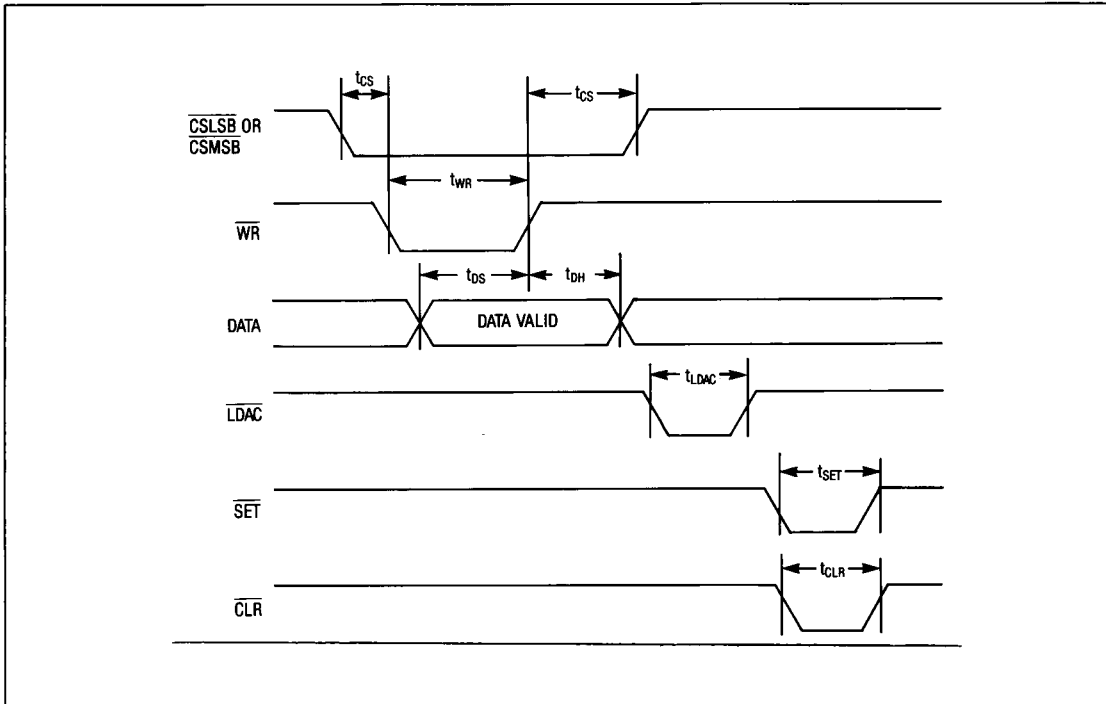

Figure 1a. MAX501 Timing Diagram

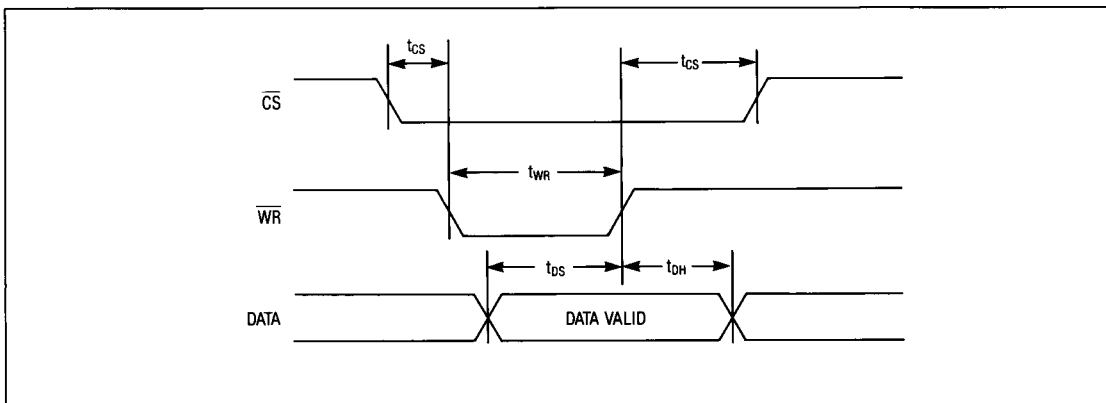

Figure 1b. MAX502 Timing Diagram

NOTES:

1. All input signal rise and fall times measured from 10% to 90% of +5V, $t_R = t_F = 20\text{ns}$.
2. Timing measurement reference level is $\frac{V_{IH} + V_{IL}}{2}$.

Voltage-Output, 12-Bit Multiplying DACs

Pin Descriptions

MAX501

PIN	NAME	FUNCTION
1	VOUT	Voltage Output
2	LDAC	Asynchronous Load DAC Input is active low
3	SET	Sets DAC register to all 1s
4	CLR	Sets DAC register to all 0s
5-8	D7-D4	Data Bits 7 to 4
9	D3/D11	Data Bit 3 or 11
10	D2/D10	Data Bit 2 or 10
11	D1/D9	Data Bit 1 or 9
12	DGND	Digital Ground
13	D0/D8	Data Bit 0 or 8 (LSB)
14	C \overline LSB	LSB Chip-Select Input is active low
15	WR	Write Input is active low
16	C \overline MSB	MSB Chip-Select Input is active low
17	VREF	Reference Input to DAC
18	AGND	Analog Ground
19	V \overline SS	-12V to -15V Supply Voltage Input
20	VDD	+12V to +15V Supply Voltage Input
21	RA	Scaling Resistor: RA = 4RFB
22	RB	Scaling Resistor: RB = 2RFB
23	RC	Scaling Resistor: RC = 2RFB
24	RFB	Feedback Resistor

MAX502

PIN	NAME	FUNCTION
1	VOUT	Voltage Output
2-11	D11-D2	Data Bits 2 to 11 (MSB)
12	DGND	Digital Ground
13,14	D1, D0	Data Bits 0 to 1 (LSB)
15	WR	Write Input is active low
16	CS	Chip-Select Input is active low
17	VREF	Reference Input to DAC
18	AGND	Analog Ground
19	V \overline SS	-12V to -15V Supply Voltage Input
20	VDD	+12V to +15V Supply Voltage Input
21	RA	Scaling Resistor: RA = 4RFB
22	RB	Scaling Resistor: RB = 2RFB
23	RC	Scaling Resistor: RC = 2RFB
24	RFB	Feedback Resistor

MAX501/MAX502

Voltage-Output, 12-Bit Multiplying DACs

Detailed Description Digital Circuit

Figures 2a and 2b are simplified circuit diagrams of the MAX501 and MAX502 input control logic. For the MAX501, a low on CSLSB and WR with CSMSB high loads the least significant bit (LSB) byte into the input register. The LSB byte is then latched into the input register on the rising edge of either a WR or a CSLSB. Similarly, a low on CSMSB and WR with CSLSB high

loads the most significant bit (MSB) nibble into the input register. The MSB nibble is then latched into the input register on the rising edge of either a WR or a CSMSB pulse. With all 12 bits loaded, a low on LDAC transfers the data to the DAC register. For the MAX502, a low on CS and WR transfers the data on the input registers to the DAC latch. Both parts' digital inputs are TTL and CMOS compatible, providing easy microprocessor (μ P) interfacing. Tables 1 and 2 are MAX501 and MAX502 truth tables.

Table 1. MAX501 Truth Table

WR	CSMSB	CSLSB	LDAC	CLR	SET	OPERATION
X	X	X	X	X	0	DAC Register overridden by 1's Input Register unaffected
X	X	X	X	0	1	DAC Register overridden by 0's Input Register unaffected
0	0	1	1	1	1	Load MSB nibble into Input Register
0	1	0	1	1	1	Load LSB byte into Input Register
X	X	X	0	1	1	Transfer Input Register to DAC Register
1	X	X	1	1	1	No Operation
0	1	1	1	1	1	No Operation
0	R	1	1	1	1	Latching MSB nibble into Input Register
R	0	1	1	1	1	Latching MSB nibble into Input Register
0	1	R	1	1	1	Latching LSB byte into Input Register
R	1	0	1	1	1	Latching LSB byte into Input Register

H = High State, L = Low State, R = Rising Edge, X = Don't Care

Table 2. MAX502 Truth Table

WR	CS	OPERATION
H	X	No Operation
X	H	No Operation
L	L	Input Register is Transparent
L	R	Input Register is Latched
R	L	Input Register is Latched

H = High State, L = Low State, R = Rising Edge, X = Don't Care

Voltage-Output, 12-Bit Multiplying DACs

MAX501/MAX502

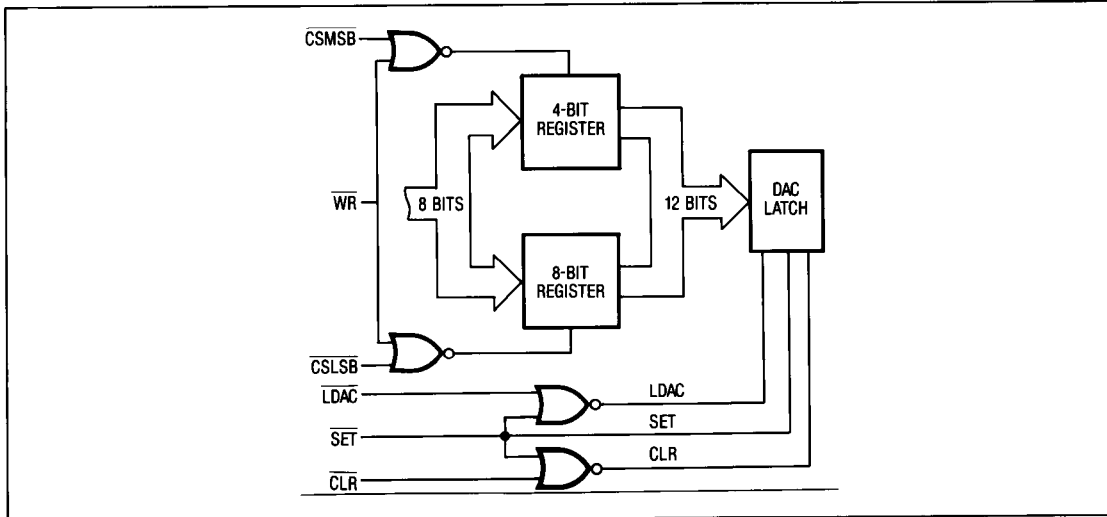

Figure 2a. MAX501 Input Control Logic

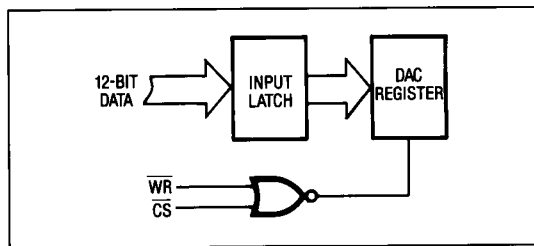

Figure 2b. MAX502 Input Control Logic

Digital-to-Analog Converter

The MAX501/MAX502 have a 12-bit, binary-weighted, current-output DAC with standard R-2R ladder (Figure 3). Binary weighted currents are switched between AGND and the inverting input of the internal output amplifier. The output amplifier, typically connected to the feedback resistor RFB, converts the output current to a voltage. With RFB connected to VOUT,

$$V_{OUT} = -D \times V_{REF}$$

where D is the fractional expression of the digital input code divided by full scale. D can vary from 0 to 4095/4096 in unipolar mode.

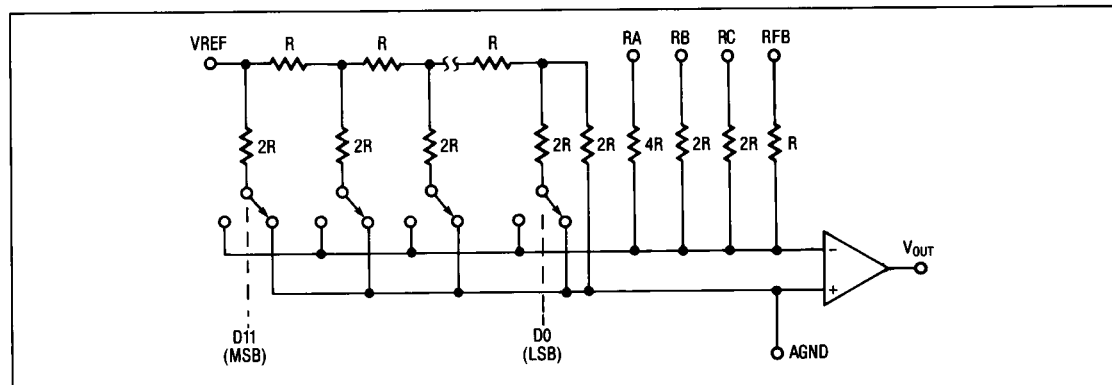

Figure 3. MAX501/MAX502 Simplified DAC and Amplifier Circuit

Voltage-Output, 12-Bit Multiplying DACs

Output-Buffer Amplifier

The output amplifier is an internally compensated, non-inverting, gain-scalable amplifier that can develop $\pm 10V$ across a $2k\Omega$ load. Maximum settling time is less than $5\mu s$ (to within 0.01% FSR). Input offset voltage is laser trimmed at the wafer level. Slew rate is typically $7V/\mu s$. The gain-setting resistors (RA, RB, and RC) connect to the amplifier inverting terminal. Float unused gain-setting resistors.

Unipolar Configuration

Figure 4, a typical configuration for the MAX501/MAX502, provides for unipolar-bipolar operation or two-quadrant multiplication when V_{IN} is an AC signal. R1 adjusts gain and R3 adjusts zero offset. For fixed-reference applications, trim the reference voltage and omit R1 and R2. If R1 and R2 are included, you must take into account their gain-temperature coefficient. The typical gain-temperature coefficient of the MAX502 is $1ppm/^{\circ}C$, which corresponds to a gain shift of $1/2LSB$ over a $+100^{\circ}C$ temperature range. Table 3 is the code table for unipolar-bipolar operation.

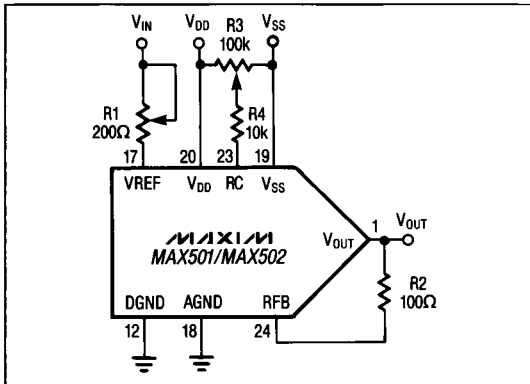

Figure 4. Unipolar-Binary Operation (2-Quadrant Multiplication)

Table 3. MAX501/MAX502 Unipolar-Binary Code Table

DIGITAL INPUT			ANALOG OUTPUT
1111	1111	1111	$(-V_{IN}) \frac{4095}{4096}$
1000	0000	0000	$(-V_{IN}) \frac{2048}{4096} = -\frac{1}{2} V_{IN}$
0000	0000	0001	$(-V_{IN}) \frac{1}{4096}$
0000	0000	0000	0V

Bipolar Operation

Figure 5 shows a 4-quadrant, bipolar operation. Gain error may be adjusted by changing the R1 and R2 ratio. These resistors should be ratio-matched to 0.01% to stay within gain-error specifications and to eliminate trimming. The offset value is defined by matching the RB and RC internal resistors. Table 4 is the code table for bipolar-binary operation.

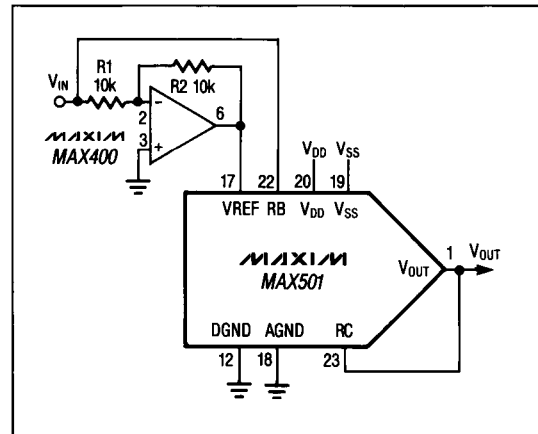

Figure 5. Bipolar Operation (4-Quadrant Multiplication)

Table 4. MAX501/MAX502 Bipolar-Binary Code Table

DIGITAL INPUT			ANALOG OUTPUT
1111	1111	1111	$(+V_{IN}) \frac{2047}{2048}$
1000	0000	0001	$(+V_{IN}) \frac{1}{2048}$
1000	0000	0000	0V
0111	1111	1111	$(-V_{IN}) \frac{1}{2048}$
0000	0000	0000	$(-V_{IN}) \frac{2048}{2048} = -V_{IN}$

Voltage-Output, 12-Bit Multiplying DACs

Applications Information

Noise

AC or transient voltages between AGND and DGND can cause noise injection into the analog output. Tie the MAX502 AGND to DGND to ensure both pins are at the same potential. If these ground pins connect to separate backplanes, use two back-to-back diodes to tie the pins together. Also, decouple VDD and VSS to AGND, as μ P-based systems generally have noisy grounds that couple into the power supplies.

Digital Glitches

Any digital word written into the DAC causes a glitch impulse. This impulse couples across the stray capacitance of the DAC switches to the output bus. A glitch impulse on this bus is converted to a voltage by RFB and the output amplifier. The output voltage glitch energy is the product of its duration and its average magnitude (the net area under the curve), and is expressed in (nV)(s). The energy is measured with VREF connected to analog ground and the DAC register alternately loaded with all 0s and all 1s.

Digital Feedthrough

Most of the MAX501/MAX502's digital inputs are directly connected to the μ P bus. These inputs are constantly changing, even when the DAC is not selected. High-frequency logic activity on the data bus can feed through the DAC package capacitance as noise on the DAC output. Figure 6 shows an interface that minimizes digital feedthrough. All data inputs are latched from the bus by CS. Alternatively, using peripheral interface devices reduces digital feedthrough.

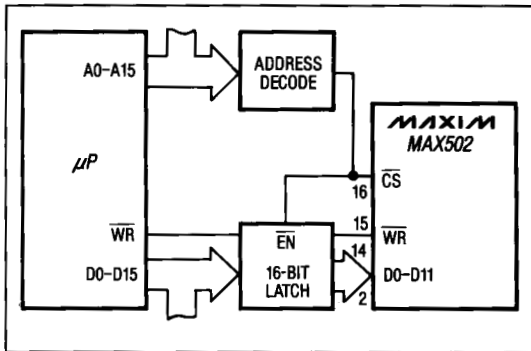

Figure 6. MAX502 Interface Circuit — Latches Minimize Digital Feedthrough

MAX502 Microprocessor Interfacing 16-Bit Microprocessor Systems

Figures 7-9 show the MAX502 interfaced with the MC68000, the 8086, and the TMS32010. The MAX502 appears as a memory-mapped peripheral to the processors. In each case, a write instruction loads the MAX502 with the appropriate data. The particular instructions used are as follows:

MC68000:	MOVE
8086:	MOV
TMS32010:	OUT

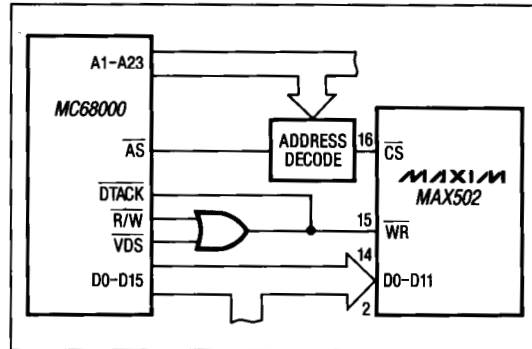

Figure 7. MAX502 to MC68000 Interface

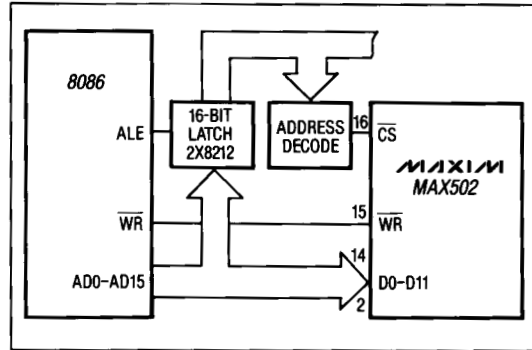

Figure 8. MAX502 to 8086 Interface

MAX501/MAX502

Voltage-Output, 12-Bit Multiplying DACs

MAX501/MAX502

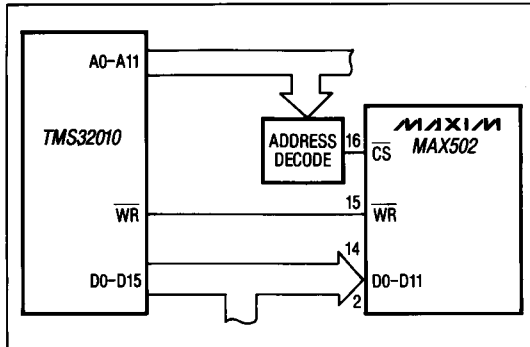

Figure 9. MAX502 to TMS32010 Interface

MAX501 Microprocessor Interfacing 8-Bit Microprocessor Systems

Figure 10 shows an interface circuit for the MAX501 to the 8085A 8-bit μ P. The software routine to load data to the device is given in Table 3. Note that transferring 12 data bits requires two write operations. The first of these loads the 4 MSBs into the 7475 latch. The second write operation loads the 8 LSBs plus the 4 MSBs (which are held by the latch) into the DAC.

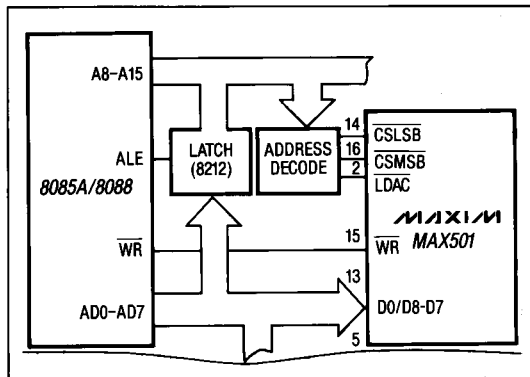
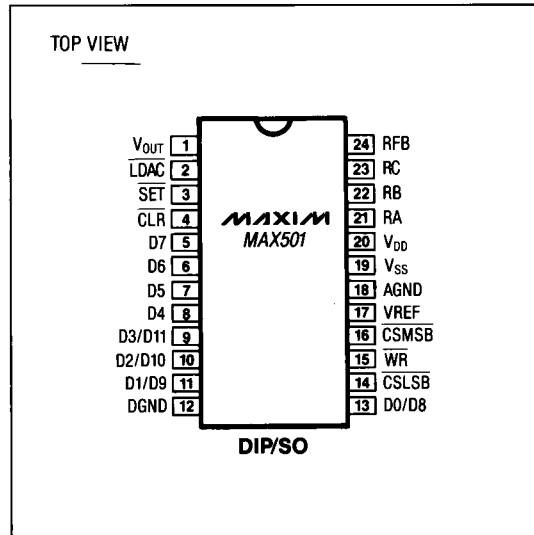

Figure 10. MAX501 to 8085A/8088 Interface

Pin Configurations (continued)



Ordering Information (continued)

PART	TEMP. RANGE	PIN-PACKAGE	ERROR (LSBs)
MAX502ACNG	0°C to +70°C	24 Narrow Plastic DIP	1/2
MAX502BCNG	0°C to +70°C	24 Narrow Plastic DIP	3/4
MAX502ACWG	0°C to +70°C	24 Wide SO	1/2
MAX502BCWG	0°C to +70°C	24 Wide SO	3/4
MAX502BC/D	0°C to +70°C	Dice*	3/4
MAX502AENG	-40°C to +85°C	24 Narrow Plastic DIP	1/2
MAX502BENG	-40°C to +85°C	24 Narrow Plastic DIP	3/4
MAX502AEWG	-40°C to +85°C	24 Wide SO	1/2
MAX502BEWG	-40°C to +85°C	24 Wide SO	3/4
MAX502AMRG	-55°C to +125°C	24 Narrow Cerdip**	1/2
MAX502BMRG	-55°C to +125°C	24 Narrow Cerdip**	3/4

* Contact factory for dice specifications.

** Contact factory for availability and processing to MIL-STD-883.

Maxim cannot assume responsibility for use of any circuitry other than circuitry entirely embodied in a Maxim product. No circuit patent licenses are implied. Maxim reserves the right to change the circuitry and specifications without notice at any time.

12 **Maxim Integrated Products, 120 San Gabriel Drive, Sunnyvale, CA 94086 (408) 737-7600**

© 1996 Maxim Integrated Products

Printed USA

MAXIM is a registered trademark of Maxim Integrated Products.