



Chipsmall Limited consists of a professional team with an average of over 10 year of expertise in the distribution of electronic components. Based in Hongkong, we have already established firm and mutual-benefit business relationships with customers from,Europe,America and south Asia,supplying obsolete and hard-to-find components to meet their specific needs.

With the principle of “Quality Parts,Customers Priority,Honest Operation,and Considerate Service”,our business mainly focus on the distribution of electronic components. Line cards we deal with include Microchip,ALPS,ROHM,Xilinx,Pulse,ON,Everlight and Freescale. Main products comprise IC,Modules,Potentiometer,IC Socket,Relay,Connector.Our parts cover such applications as commercial,industrial, and automotives areas.

We are looking forward to setting up business relationship with you and hope to provide you with the best service and solution. Let us make a better world for our industry!



Contact us

Tel: +86-755-8981 8866 Fax: +86-755-8427 6832

Email & Skype: info@chipsmall.com Web: www.chipsmall.com

Address: A1208, Overseas Decoration Building, #122 Zhenhua RD., Futian, Shenzhen, China





MAX5092 Evaluation Kit

General Description

The MAX5092 evaluation kit (EV kit) is a fully assembled and tested surface-mount printed-circuit board (PCB) demonstrating the MAX5092B, a low-dropout (LDO) regulator with internal boost preregulator. The EV kit operates from a 4V to 72V input voltage and delivers up to 250mA from a preprogrammed 7V boost preregulator output (BSOUT) and 5V LDO output (VOUT). Both the LDO and the boost preregulator output voltages are programmable using external resistors.

The MAX5092 EV kit features include on-board jumper settings that allow for evaluation of the ENABLE and HOLD functions of the MAX5092, a power-on-reset output ($\overline{\text{RESET}}$) to indicate LDO out-of-regulation conditions, and a programmable $\overline{\text{RESET}}$ time period.

The MAX5092 EV kit can be configured to demonstrate the MAX5092A (3.3V LDO output) or the MAX5093A/MAX5093B. To evaluate the MAX5092A, replace the IC with the MAX5092A. To evaluate the MAX5093_, the addition of an external Schottky diode is required. See the *Configuring for the MAX5093_* section to modify the MAX5092 EV kit for the MAX5093_.

The EV kit comes fully assembled and tested, is qualified lead-free, and is rated for an operating temperature range of 0°C to +70°C.

Warning: The MAX5092 EV kit is designed to operate with high voltages. Dangerous voltages can be present on this EV kit and on equipment connected to it. Users who power up this EV kit, or the power sources connected to it, must be careful to follow safety procedures appropriate when working with high-voltage electrical equipment.

Features

- ◆ Wide 4V to 72V Input-Voltage Range
- ◆ Preset 5V LDO Output Voltage
- ◆ Preset 7V Boost Preregulator Output Voltage
- ◆ Adjustable LDO Output Voltage from 1.5V to 9V
- ◆ Adjustable Boost Preregulator Output Voltage Up to 11V
- ◆ Jumper-Programmable ENABLE and $\overline{\text{HOLD}}$ Functions
- ◆ Programmable $\overline{\text{HOLD}}$ Time Period
- ◆ Surface-Mount Components
- ◆ Lead-Free Evaluation Kit
- ◆ Fully Assembled and Tested

Ordering Information

PART	TYPE
MAX5092EVKIT+	EV Kit

+Denotes lead-free and RoHS-compliant.

Note: To evaluate the MAX5092A, request a MAX5092AATE+ free sample with the MAX5092EVKIT+. To evaluate the MAX5093_, request a MAX5093AATE+/MAX5093BATE+ free sample with the MAX5092EVKIT+.

Component List

DESIGNATION	QTY	DESCRIPTION
C1	1	47 μ F, 80V, 0.7 Ω SMT Al electrolytic capacitor (G) Panasonic EEEFK1K470P
C2, C3	2	1 μ F \pm 10%, 100V X7R ceramic capacitors (1210) Murata GRM32CR72A105K or equivalent
C4	1	22 μ F, 80V, 1.3 Ω SMT Al electrolytic capacitor (F) Panasonic EEEFK1K220P
C5	1	0.22 μ F \pm 10%, 16V X7R ceramic capacitor (0603) TDK C1608X7R1C224K or equivalent

DESIGNATION	QTY	DESCRIPTION
C6	1	1 μ F \pm 10%, 16V X7R ceramic capacitor (0603) TDK 1608X7R1C105K or equivalent
C7	1	10 μ F \pm 10%, 25V X5R ceramic capacitor (1206) Murata GRM31CR61E106K or equivalent
C8	0	Not installed, ceramic capacitor (0603)
D1	0	Not installed (SMB) Recommended diode: 2A, 100V Schottky diode Diodes Inc. B2100 or equivalent

MAX5092 Evaluation Kit

Component List (continued)

DESIGNATION	QTY	DESCRIPTION
JU1, JU2	2	3-pin headers 36-pin headers, 0.1 centers (comes in 36-pin strips, cut to fit) Sullins PEC36SAAN Digi-Key S1012E-36-ND
L1	1	4.7 μ H, 4.8A 18m Ω inductor (9.4mm x 12.95mm x 5.21mm) Coilcraft DO3316P-472ML
R1, R4	0	Not installed (0603)

DESIGNATION	QTY	DESCRIPTION
R2, R5	2	0 Ω resistors (0603)
R3	1	100k Ω \pm 5% resistor (0603)
U1	1	MAX5092BATE+ (16-pin, 5mm x 5mm, Thin QFN)
—	2	Shunt Sullins STC02SYAN Digi-Key S9000-ND
—	1	PCB: MAX5092 Evaluation Kit+

Component Suppliers

SUPPLIER	COMPONENTS	PHONE	WEBSITE
Coilcraft, Inc.	Inductors	847-639-6400	www.coilcraft.com
Digi-Key	Headers, jumpers	800-344-4539	www.digikey.com
Murata Mfg. Co., Ltd.	Capacitors	770-436-1300	www.murata.com
Panasonic Corp.	Resistors, capacitors	714-373-7366	www.maco.panasonic.co.jp
Sullins Electronics	Headers, jumpers	760-744-0125	www.sullinselectronics.com
TDK Corp.	Capacitors	888-835-6646	www.component.tdk.com

Note: Indicate that you are using the MAX5092A, MAX5092B, MAX5093A, or MAX5093B when contacting these component suppliers.

Quick Start

Recommended Equipment

Before beginning, the following equipment is needed:

- One variable-DC power supply (further referred to as PS1) capable of supplying up to 72V at 1A
- One adjustable load capable of sinking 250mA at 5V
- Three digital voltmeters (DVMs)
- One ammeter (for optional low-quiescent input current evaluation)

Procedure

The MAX5092 EV kit is fully assembled and tested. Follow the steps below to verify board operation. See Figure 1 for test setup.

Warning: The MAX5092 EV kit is designed to operate with high voltages. Dangerous voltages can be present on this EV kit and on equipment connected to it. Users who power up this EV kit, or the power sources connected to it, must be careful to follow safety procedures appropriate when working with high-voltage electrical equipment.

- 1) Preset PS1 to +4V. Turn off PS1. **Caution: Do not turn on the power supply until all connections are complete.**
- 2) Connect the positive terminal of PS1 to the VIN pad located on the EV kit. Connect the negative terminal of PS1 to the GND pad located on the EV kit.
- 3) Connect the positive input of one DVM to the VIN pad located on the EV kit. Connect the negative input of that DVM to the GND pad located on the EV kit. This DVM measures the EV kit input voltage.
- 4) Connect the positive input of the second DVM to the BSOUT pad located on the EV kit. Connect the negative input of that DVM to the GND pad located on the EV kit. This DVM measures the output voltage at the boost converter output.
- 5) Connect the positive input of the third DVM to the VOUT pad located on the EV kit. Connect the negative input of that DVM to the GND pad located on the EV kit. This DVM measures the output voltage at the LDO output.

MAX5092 Evaluation Kit

Evaluates: MAX5092B/92A/MAX5093B/93A

- 6) Connect dummy load between the VOUT and GND pads located on the EV kit. Adjust the load to 250mA.
 - 7) Verify that a shunt is installed on pins 2-3 of jumper JU1 to enable the MAX5092B.
 - 8) Verify that a shunt is installed pins 2-3 of jumper JU2 to disable the HOLD function of the MAX5092B.
 - 9) Turn on PS1 and sweep the input voltage from 4V to 7V to 3.5V as indicated on the input DVM. Verify that the BSOUT DVM indicates approximately 7V over the input-voltage range. Verify that the VOUT DVM indicates approximately 5V over the input-voltage range. Note that the MAX5092 still properly regulates the outputs with VIN as low as 3.5V after the IC is started.
 - 10) Reduce the dummy load to 10mA.
 - 11) Increase PS1 to 7V.
 - 12) **Warning: Dangerous voltages are present on the EV kit during this step.** Sweep the PS1 voltage from 7V to 72V. Verify that the BSOUT DVM voltage follows the input DVM voltage, minus a diode drop,
- over the input-voltage range. Verify that the VOUT DVM indicates approximately 5V over the input-voltage range.
 - 13) Optional procedure to observe the MAX5092 low-quiescent input current (I_Q):
 - a) Set the PS1 voltage to 14V. The boost converter is not switching.
 - b) Turn off PS1. **Caution: Do not turn on the power supply until all connections are complete.**
 - c) Remove the load from VOUT.
 - d) Remove all the DVMs to eliminate the DVM contribution to I_Q .
 - e) Remove the wire between PS1 and the VIN pad on the EV kit.
 - f) Connect the positive terminal of PS1 to the positive terminal of the ammeter. Connect the negative terminal of this ammeter to the VIN pad located on the EV kit. This ammeter measures I_Q .
 - g) Turn on PS1. Observe that the ammeter indicates an I_Q less than 85 μ A.

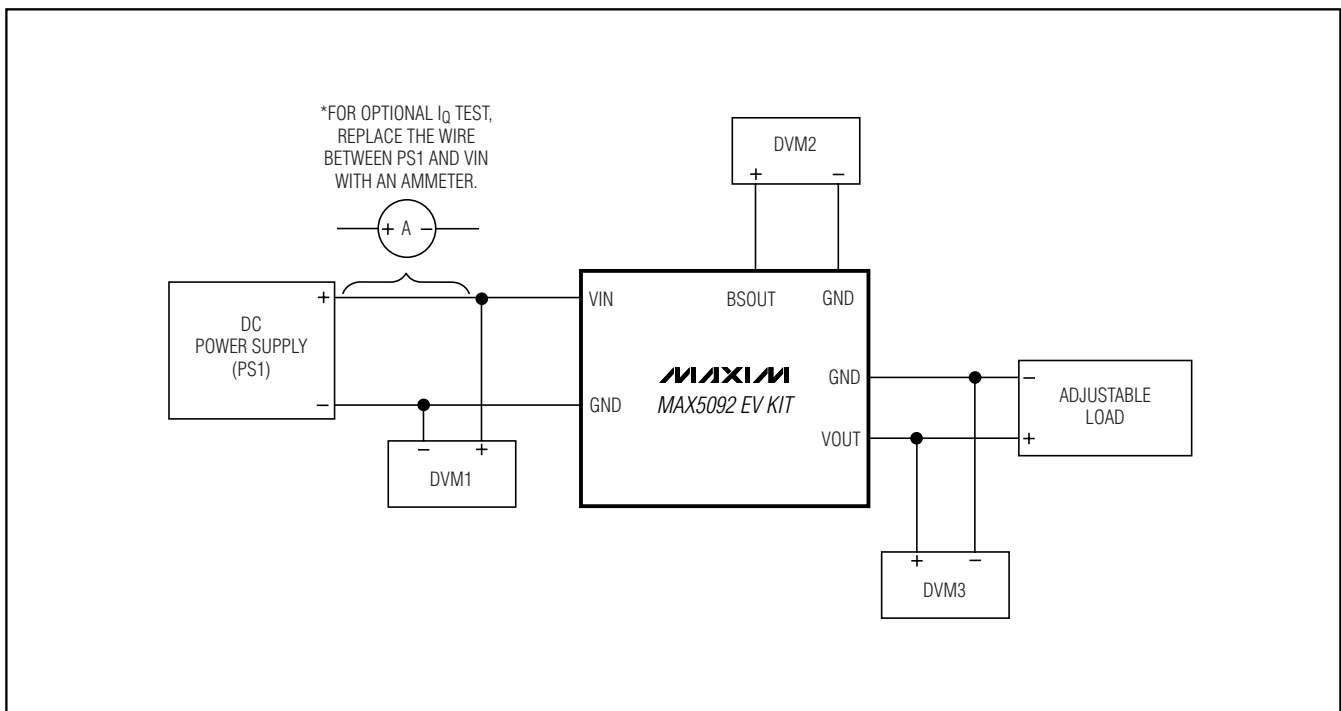

Figure 1. MAX5092 EV Kit Test Connections

MAX5092 Evaluation Kit

Detailed Description

The MAX5092 evaluation kit (EV kit) is a fully assembled and tested surface-mount PCB demonstrating the MAX5092B LDO with internal boost preregulator IC. The EV kit operates from a 4V to 72V input voltage and delivers up to 250mA from a preprogrammed 7V boost preregulator output (BSOUT) and 5V LDO output (VOUT).

VOUT can deliver up to 250mA total output current. The voltage maintained at BSOUT depends upon the input voltage and the programmed BSOUT regulation voltage. When $(V_{BSOUT} - V_{OUT})$ is less than the boost disable threshold (2.5V typ), V_{BSOUT} is boosted to its programmed regulation voltage. As V_{VIN} increases above the BSOUT regulation voltage, causing $(V_{BST_OUT} - V_{OUT})$ to be greater than the boost disable threshold, V_{BSOUT} follows V_{VIN} , minus a diode drop.

Both the LDO and boost preregulator output voltages can be programmed using external resistors. The boost output voltage (V_{BSOUT}) is adjustable up to 11V by selecting resistors R1 and R2. The LDO output voltage (V_{VOUT}) is adjustable from 1.5V to 9V by selecting resistors R4 and R5. See the *Evaluating Other Output Voltages* section for more details. If it is desired to program V_{BSOUT} to voltages up to 12V, use the MAX5093_ IC. See the *Configuring for the MAX5093_* section for more details.

The MAX5092_/MAX5093_ feature an internal voltage regulator that is used to supply all internal low-voltage blocks within the IC. An output on the EV kit (VL) is provided to monitor the internal regulator voltage. V_{VL} regulates to 5.5V when V_{BSOUT} is above 5.5V. V_{VL} tracks the voltage at BSOUT when V_{BSOUT} is below 5.5V. VL is not intended to supply an external load.

The MAX5092 EV kit utilizes two jumpers (JU1 and JU2) to control the ENABLE and $\overline{\text{HOLD}}$ functions of the MAX5092 IC. See Table 1 for jumper descriptions. Shunt pins 2-3 of jumper JU1 to enable the MAX5092. Shunt pins 1-2 of jumper JU1 to disable the MAX5092. Shunt pins 1-2 of jumper JU2 to enable $\overline{\text{HOLD}}$ mode. Shunt pins 2-3 of jumper JU2 to disable $\overline{\text{HOLD}}$ mode. Enabling $\overline{\text{HOLD}}$ prevents the IC from shutting down if EN is brought low. The ENABLE function is also controlled by an external voltage source by connecting the external source to the ENABLE pad on the EV kit. When controlling ENABLE from an external source, ensure the shunt on jumper JU1 is removed. Refer to the MAX5092A/

Table 1. JU1 and JU2 Jumper Positions

JUMPER	POSITION	FUNCTION
JU1	1-2	Sets ENABLE low (disables IC)
	2-3	Sets ENABLE high (enables IC)
JU2	1-2	Sets $\overline{\text{HOLD}}$ low (enables $\overline{\text{HOLD}}$)
	2-3	Sets $\overline{\text{HOLD}}$ high (disables $\overline{\text{HOLD}}$)

MAX5092B/MAX5093A/MAX5093B data sheet for a more detailed description of the ENABLE and $\overline{\text{HOLD}}$ timing functions.

The MAX5092 contains a power-on-reset output ($\overline{\text{RESET}}$) that indicates when the LDO output voltage (V_{VOUT}) is out of regulation. If V_{VOUT} falls below 90% of the programmed regulation threshold, $\overline{\text{RESET}}$ pulls low after a short timeout period. Once V_{VOUT} rises above 92% of the programmed regulation threshold, $\overline{\text{RESET}}$ goes high after the user-programmable timeout period. Capacitor C5 sets the $\overline{\text{RESET}}$ timeout period. See the *Adjusting the RESET Timeout Period* section for more details.

The MAX5092A IC (3.3V LDO output) can be used with this EV kit. Refer to the MAX5092/MAX5093 IC data sheet for operation. The MAX5092 EV kit can be configured for the MAX5093_ IC using an external Schottky diode. Use the MAX5093_ for higher boost voltage applications up to 12V or to lower package power dissipation. See the *Configuring for the MAX5093_* to modify the MAX5092 EV kit for use with the MAX5093_.

Customizing the MAX5092 EV Kit

Evaluating Other Output Voltages

Setting the Boost Output Voltage (V_{BSOUT})

The MAX5092_/MAX5093_ feature Dual Mode™ operation for regulating the boost-converter output voltage. These devices operate in either preset output-voltage mode or adjustable output-voltage mode. In preset mode, internal trimmed feedback resistors set V_{BSOUT} to a fixed 7V. The default EV kit is configured for the BSOUT preset mode by directly connecting BSFB to SGND (Figure 2). In adjustable output mode, V_{BSOUT} can be programmed up to 11V for the MAX5092_ (or up to 12V for the MAX5093_) by selecting resistors R1 and R2. Note that the current drawn by these resistors adds to the quiescent current and the shutdown current of the IC. Use the adjustable output mode only if V_{BSOUT} is required to be significantly different than the

Dual Mode is a trademark of Maxim Integrated Products, Inc.

MAX5092 Evaluation Kit

Evaluates: MAX5092B/92A/MAX5093B/93A

preset 7V. If V_{BSOUT} is programmed greater than ($V_{OUT} + V_{BST_DIS}$), larger ripple is observed on BSOUT. The reason is that as V_{BSOUT} rises above ($V_{OUT} + V_{BST_DIS}$), the boost converter is disabled, causing V_{BSOUT} to fall. As V_{BSOUT} falls to ($V_{OUT} + V_{BST_EN}$), the boost converter turns back on and V_{BSOUT} rises. For the lowest V_{BSOUT} ripple, program V_{BSOUT} within the boost disable threshold.

To program V_{BSOUT} for other voltages, use the following procedure:

- 1) Select a R2 resistance of 499k Ω or lower.
- 2) Calculate R1 using the following equation:

$$R1 = R2 \times \left(\frac{V_{BSOUT}}{1.24} - 1 \right)$$

where V_{BSOUT} is the desired output voltage for BSOUT.

- 3) Remove the short located at R2.
- 4) Install resistors R1 and R2.

See Figure 2 for the MAX5092 EV kit schematic.

Setting the LDO Output Voltage (VOUT)

LDO output-voltage regulation also features Dual Mode operation. In preset mode, V_{VOUT} regulates to 3.3V (MAX5092A/MAX5093A) or 5V (MAX5092B/MAX5093B) by internal trimmed feedback resistors. The default EV kit VOUT regulation mode is configured for the preset mode by directly connecting SET to SGND (Figure 2). V_{VOUT} can also be adjusted from 1.5V to 9V for the MAX5092_ (or from 1.5V to 10V for the MAX5093_) by selecting resistors R4 and R5. Note that the current drawn by these resistors adds to the quiescent current of the LDO. Use the adjustable output mode only if V_{VOUT} is required to be significantly different than the preset voltage. To program V_{VOUT} for other voltages, use the following procedure:

- 1) Select an R5 resistance of 100k Ω or lower.
- 2) Calculate R4 using the following equation:

$$R4 = R5 \times \left(\frac{V_{VOUT}}{1.24} - 1 \right)$$

where V_{VOUT} is the desired output voltage for VOUT.

- 3) Remove the short located at R5.
- 4) Install resistors R4 and R5.

See Figure 2 for the MAX5092 EV kit schematic.

Adjusting the RESET Timeout Period

The MAX5092 EV kit contains an open-drain power-on reset output (\overline{RESET}) that indicates when the LDO output (V_{OUT}) is out of regulation. When V_{VOUT} rises above 92% of the regulation threshold, \overline{RESET} goes high after a user-programmable timeout period. This time period is programmable by selecting the capacitance of capacitor C5 (Figure 2). For a chosen \overline{RESET} active timeout period (t_{RESET_HIGH}) in seconds, calculate the required C5 value in farads as:

$$C5 = \frac{2 \times 10^{-6} \times t_{RESET_HIGH}}{1.24}$$

The \overline{RESET} active timeout period is set for approximately 136ms by C5 in the default EV kit configuration.

Configuring for the MAX5093_

The MAX5092 EV kit can be configured to demonstrate the MAX5093_. The MAX5093_ requires an external switching diode (D1) connected between LX and BSOUT (Figure 2). Proper selection of an external diode can offer a lower forward-voltage drop and a higher reverse-voltage handling capability. Since the high-switching frequency of the IC demands a high-speed rectifier, Schottky diodes are recommended for most applications because of their fast recovery time and low forward-voltage drop. Ensure that the diode's peak current rating is greater than or equal to the peak inductor current. Additionally, the diode reverse breakdown voltage must be greater than V_{BSOUT} .

To configure the MAX5092 EV kit for use with the MAX5093_, perform the following procedure:

- 1) Replace the MAX5092B IC with the MAX5093_ IC.
- 2) Install Schottky diode D1. See the *Component List* for recommended diode.
- 3) Configure the BSOUT and VOUT voltages as discussed in the *Evaluating Other Output Voltages* section.

MAX5092 Evaluation Kit

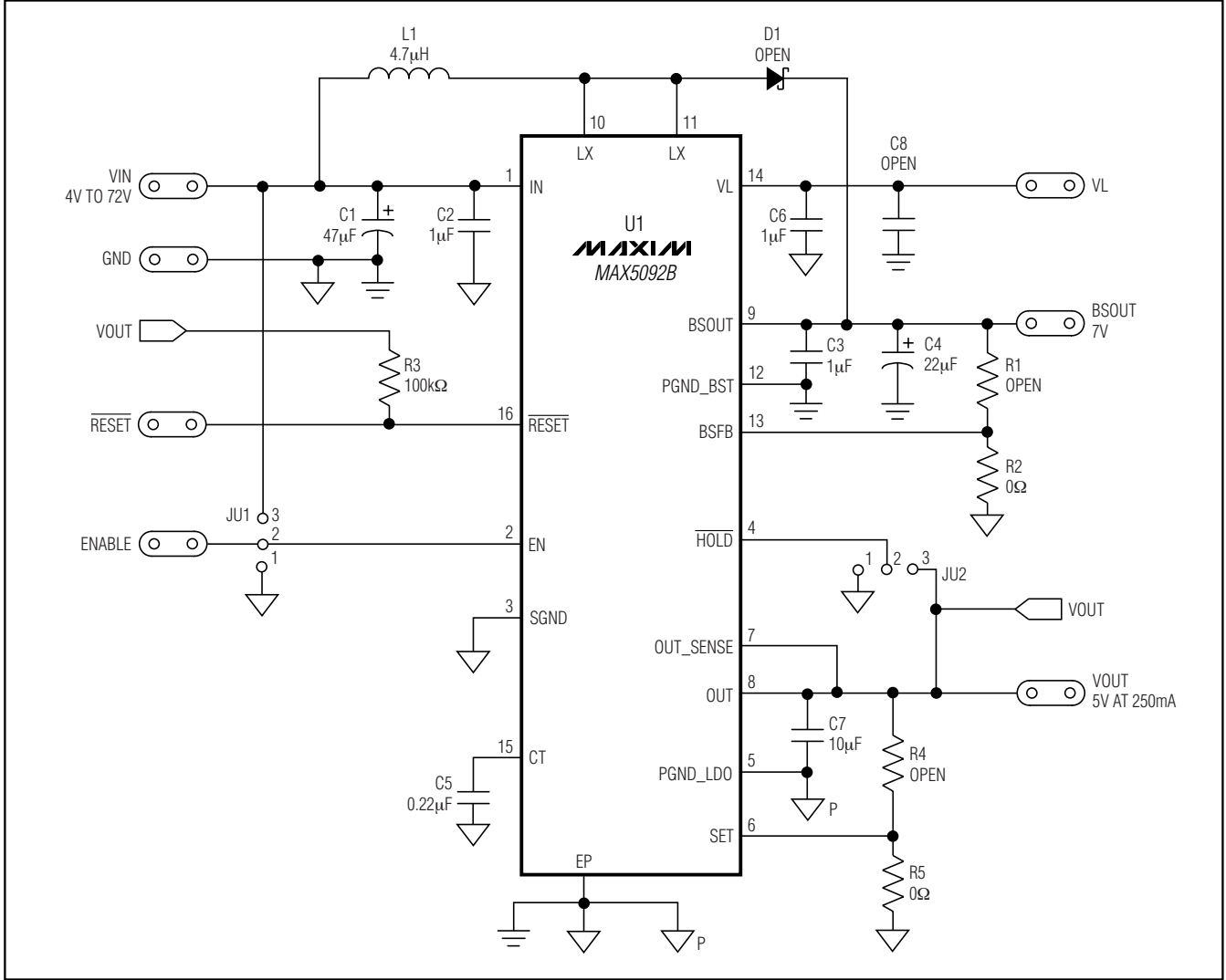

Figure 2. MAX5092B EV Kit Schematic

MAX5092 Evaluation Kit

Evaluates: MAX5092B/92A/MAX5093B/93A

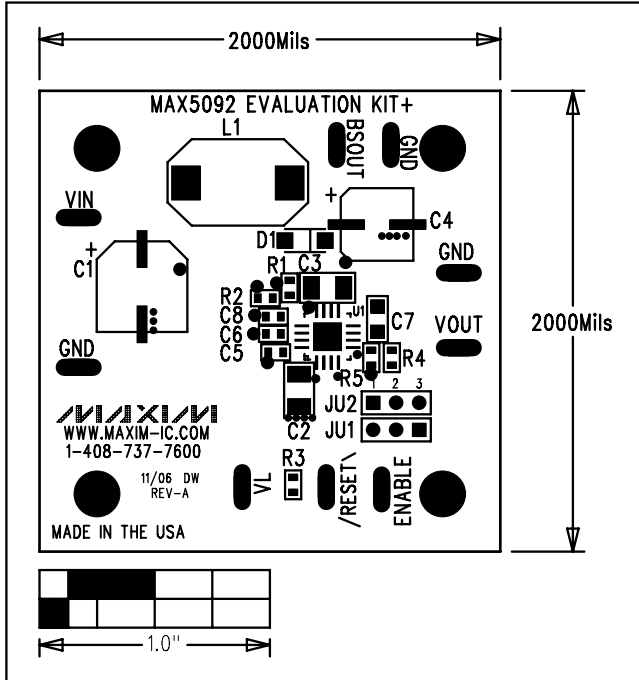

Figure 3. MAX5092EV Kit Component Placement Guide—Top Silkscreen

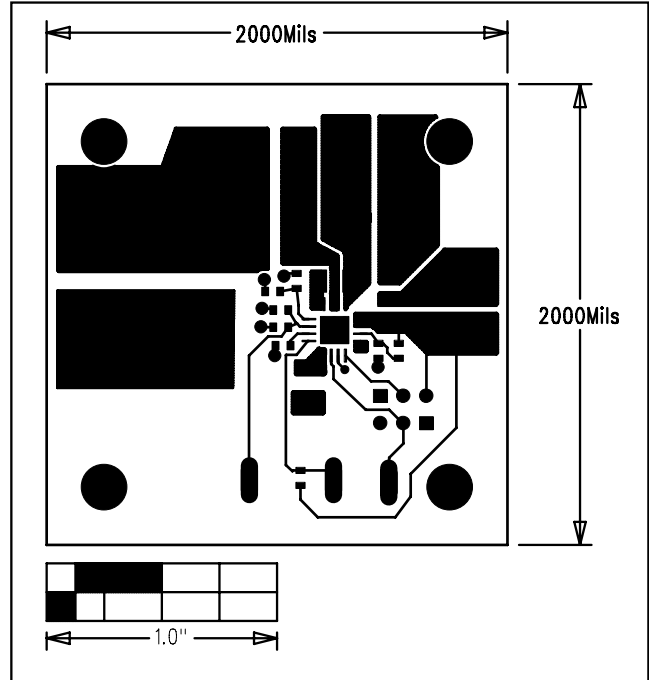

Figure 4. MAX5092 EV Kit PCB Layout—Solder Side Top

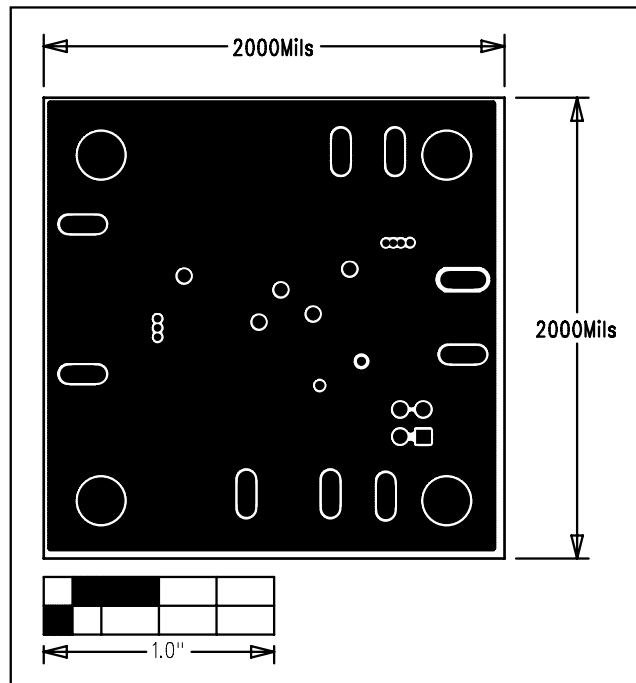

Figure 5. MAX5092 EV Kit PCB Layout—AGND Inner Layer 2

MAX5092 Evaluation Kit

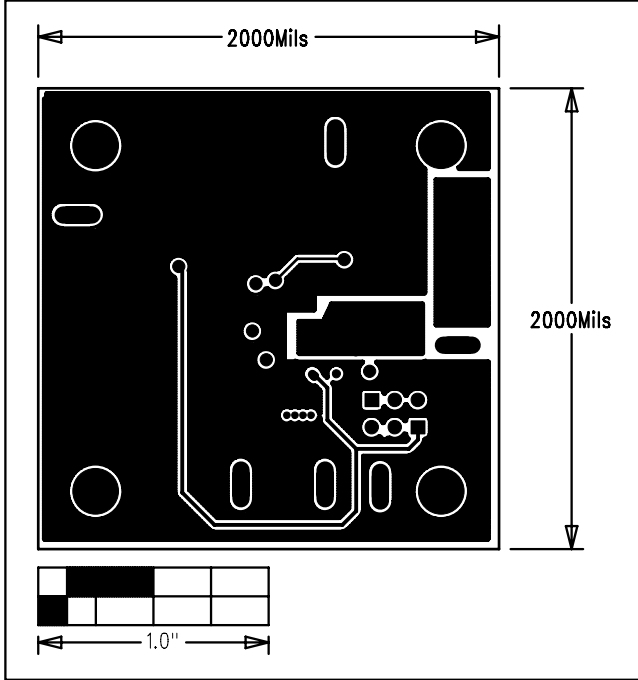

Figure 6. MAX5092 EV Kit PCB Layout—PGND Inner Layer 3

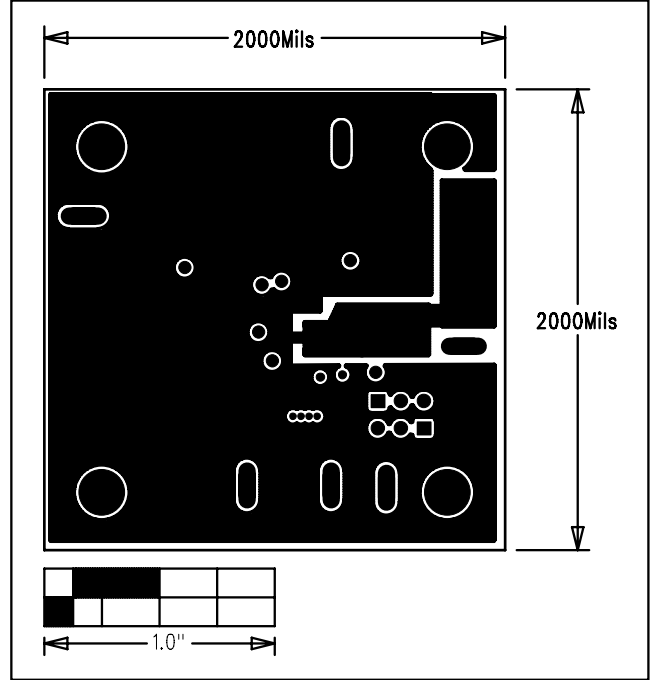

Figure 7. MAX5092 EV Kit PCB Layout—Solder Side Bottom

Maxim cannot assume responsibility for use of any circuitry other than circuitry entirely embodied in a Maxim product. No circuit patent licenses are implied. Maxim reserves the right to change the circuitry and specifications without notice at any time.

8 **Maxim Integrated Products, 120 San Gabriel Drive, Sunnyvale, CA 94086 408-737-7600**

© 2007 Maxim Integrated Products

MAXIM is a registered trademark of Maxim Integrated Products, Inc.