



Chipsmall Limited consists of a professional team with an average of over 10 year of expertise in the distribution of electronic components. Based in Hongkong, we have already established firm and mutual-benefit business relationships with customers from,Europe,America and south Asia,supplying obsolete and hard-to-find components to meet their specific needs.

With the principle of “Quality Parts,Customers Priority,Honest Operation,and Considerate Service”,our business mainly focus on the distribution of electronic components. Line cards we deal with include Microchip,ALPS,ROHM,Xilinx,Pulse,ON,Everlight and Freescale. Main products comprise IC,Modules,Potentiometer,IC Socket,Relay,Connector.Our parts cover such applications as commercial,industrial, and automotives areas.

We are looking forward to setting up business relationship with you and hope to provide you with the best service and solution. Let us make a better world for our industry!



Contact us

Tel: +86-755-8981 8866 Fax: +86-755-8427 6832

Email & Skype: info@chipsmall.com Web: www.chipsmall.com

Address: A1208, Overseas Decoration Building, #122 Zhenhua RD., Futian, Shenzhen, China





+5V/+3V, 13-Bit, Serial, Force/Sense DACs with 10ppm/°C Internal Reference

General Description

The MAX5132/MAX5133 low-power, 13-bit, voltage-output digital-to-analog converters (DACs) feature an internal precision bandgap reference and output amplifier.

The MAX5132 operates on a single +5V supply with an internal reference of +2.5V and offers a configurable output amplifier. If necessary, the user can override the on-chip, <math><10\text{ppm}/^\circ\text{C}</math> voltage reference with an external reference. The MAX5133 has the same features as the MAX5132 but operates from a single +3V supply and has an internal +1.25V precision reference. The user-accessible inverting input and output of the amplifier allows specific gain configurations, remote sensing, and high output drive capability for a wide range of force/sense applications. Both devices draw only 500 μA of supply current, which reduces to 3 μA in power-down mode. In addition, their power-up reset feature allows for a user-selectable initial output state of either 0V or mid-scale and reduces output glitches during power-up.

The serial interface is compatible with SPI™, QSPI™, and MICROWIRE™, which makes the MAX5132/MAX5133 suitable for cascading multiple devices. Each DAC has a double-buffered input organized as an input register followed by a DAC register. A 16-bit shift register loads data into the input register. The DAC register may be updated independently or simultaneously with the input register.

Both devices are available in a 16-pin QSOP package and are specified for the extended-industrial (-40°C to +85°C) operating temperature range. For pin-compatible 14-bit upgrades, see the MAX5171/MAX5173 data sheet; for pin-compatible 12-bit versions, see the MAX5122/MAX5123 data sheet.

Applications

Industrial Process Control
Automatic Test Equipment (ATE)
Digital Offset and Gain Adjustment
Motion Control
Microprocessor-Controlled Systems

SPI and QSPI are trademarks of Motorola, Inc.
MICROWIRE is a trademark of National Semiconductor Corp.



Maxim Integrated Products 1

For free samples & the latest literature: <http://www.maxim-ic.com>, or phone 1-800-998-8800.
For small orders, phone 1-800-835-8769.

Features

- ◆ Single-Supply Operation
 - +5V (MAX5132)
 - +3V (MAX5133)
- ◆ Built-In 10ppm/°C max Precision Bandgap Reference
 - +2.5V (MAX5132)
 - +1.25V (MAX5133)
- ◆ SPI/QSPI/MICROWIRE-Compatible, 3-Wire Serial Interface
- ◆ Pin-Programmable Shutdown-Mode and Power-Up Reset (0V or Midscale Output Voltage)
- ◆ Buffered Output Capable of Driving 5k Ω || 100pF or 4–20mA Loads
- ◆ Space-Saving 16-Pin QSOP Package
- ◆ Pin-Compatible Upgrades for the 12-Bit MAX5122/MAX5123
- ◆ Pin-Compatible 14-Bit Upgrades Available (MAX5171/MAX5173)

Ordering Information

PART	TEMP. RANGE	PIN-PACKAGE	INL (LSB)
MAX5132AEEE	-40°C to +85°C	16 QSOP	± 0.5
MAX5132BEEE	-40°C to +85°C	16 QSOP	± 1
MAX5133AEEE	-40°C to +85°C	16 QSOP	± 1
MAX5133BEEE	-40°C to +85°C	16 QSOP	± 2

Pin Configuration

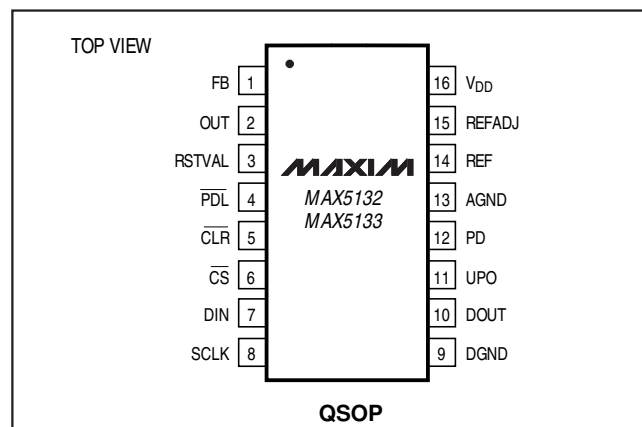

MAX5132/MAX5133

+5V/+3V, 13-Bit, Serial, Force/Sense DACs with 10ppm/°C Internal Reference

ABSOLUTE MAXIMUM RATINGS

V _{DD} to AGND, DGND	-0.3V to +6V	Maximum Current into Any Pin.....	50mA
AGND to DGND.....	-0.3V to +0.3V	Continuous Power Dissipation (T _A = +70°C)	
Digital Inputs to DGND	-0.3V to +6V	16-Pin QSOP (derate 8.00mW/°C above +70°C).....	667mW
Digital Outputs (DOUT, UPO) to DGND	-0.3V to (V _{DD} + 0.3V)	Operating Temperature Range	-40°C to +85°C
FB, OUT to AGND	-0.3V to (V _{DD} + 0.3V)	Storage Temperature Range	-65°C to +150°C
REF, REFADJ to AGND	-0.3V to (V _{DD} + 0.3V)	Lead Temperature (soldering, 10sec)	+300°C

Stresses beyond those listed under "Absolute Maximum Ratings" may cause permanent damage to the device. These are stress ratings only, and functional operation of the device at these or any other conditions beyond those indicated in the operational sections of the specifications is not implied. Exposure to absolute maximum rating conditions for extended periods may affect device reliability.

ELECTRICAL CHARACTERISTICS—MAX5132 (+5V)

(V_{DD} = +5V ±10%, AGND = DGND, 33nF capacitor at REFADJ, internal reference, R_L = 5kΩ, C_L = 100pF, output amplifier connected in unity-gain, T_A = T_{MIN} to T_{MAX}, unless otherwise noted. Typical values are at T_A = +25°C.)

PARAMETER	SYMBOL	CONDITIONS	MIN	TYP	MAX	UNITS
STATIC PERFORMANCE						
Resolution	N		13			Bits
Integral Nonlinearity (Note 1)	INL	MAX5132A	-0.5		0.5	LSB
		MAX5132B	-1		1	
Differential Nonlinearity	DNL		-1		1	LSB
Offset Error (Note 2)	V _{OS}		-10		10	mV
Gain Error	GE		-3	-0.2	3	mV
Full-Scale Temperature Coefficient (Note 3)	TCV _{FS}	MAX5132A		3	10	ppm/°C
		MAX5132B		10	30	
Power-Supply Rejection Ratio	PSRR	4.5V ≤ V _{DD} ≤ 5.5V		20	250	μV/V
REFERENCE						
Output Voltage	V _{REF}	T _A = +25°C	2.475	2.5	2.525	V
Output Voltage Temperature Coefficient	TCV _{REF}	MAX5132A		3		ppm/°C
		MAX5132B		10		
Reference External Load Regulation	V _{OUT} /I _{OUT}	0 ≤ I _{OUT} ≤ 100μA (sourcing)			50	μV/μA
Reference Short-Circuit Current				4		mA
REFADJ Current		REFADJ = V _{DD}		3.3	7	μA
DIGITAL INPUT						
Input High Voltage	V _{IH}		3			V
Input Low Voltage	V _{IL}				0.8	V
Input Hysteresis	V _{HYS}			200		mV
Input Leakage Current	I _{IN}	V _{IN} = 0 or V _{DD}	-1	0.001	1	μA
Input Capacitance	C _{IN}			8		pF
DIGITAL OUTPUTS						
Output High Voltage	V _{OH}	I _{SOURCE} = 2mA	V _{DD} - 0.5			V
Output Low Voltage	V _{OL}	I _{SINK} = 2mA		0.13	0.4	V

+5V/+3V, 13-Bit, Serial, Force/Sense DACs with 10ppm/°C Internal Reference

MAX5132/MAX5133

ELECTRICAL CHARACTERISTICS—MAX5132 (+5V) (continued)

(V_{DD} = +5V ±10%, AGND = DGND, 33nF capacitor at REFADJ, internal reference, R_L = 5kΩ, C_L = 100pF, output amplifier connected in unity-gain, T_A = T_{MIN} to T_{MAX}, unless otherwise noted. Typical values are at T_A = +25°C.)

PARAMETER	SYMBOL	CONDITIONS	MIN	TYP	MAX	UNITS
DYNAMIC PERFORMANCE						
Voltage Output Slew Rate	SR			0.6		V/μs
Output Settling Time		To ±0.5LSB, V _{STEP} = 2.5V		20		μs
Output Voltage Swing (Note 4)				0 to V _{DD}		V
Current into FB			-0.1	0	0.1	μA
Time Required to Exit Shutdown				2		ms
Digital Feedthrough		$\overline{CS} = V_{DD}$, f _{SCLK} = 100kHz, V _{SCLK} = 5Vp-p		5		nV-s
POWER REQUIREMENTS						
Power-Supply Voltage (Note 5)	V _{DD}		4.5		5.5	V
Power-Supply Current (Note 5)	I _{DD}			500	600	μA
Power-Supply Current in Shutdown	I _{SHDN}			3	20	μA

ELECTRICAL CHARACTERISTICS—MAX5133 (+3V)

(V_{DD} = +3V ±10%, AGND = DGND, 33nF capacitor at REFADJ, internal reference, R_L = 5kΩ, C_L = 100pF, output amplifier connected in unity-gain, T_A = T_{MIN} to T_{MAX}, unless otherwise noted. Typical values are at T_A = +25°C.)

PARAMETER	SYMBOL	CONDITIONS	MIN	TYP	MAX	UNITS
STATIC PERFORMANCE						
Resolution	N		13			Bits
Integral Nonlinearity (Note 1)	INL	MAX5133A	-1		1	LSB
		MAX5133B	-2		2	
Differential Nonlinearity	DNL		-1		1	LSB
Offset Error (Note 2)	V _{OS}		-10		10	mV
Gain Error	GE		-5	-0.2	5	mV
Full-Scale Temperature Coefficient (Note 3)	TCV _{FS}	MAX5133A		3	10	ppm/°C
		MAX5133B		10	30	
Power-Supply Rejection Ratio	PSRR	2.7V ≤ V _{DD} ≤ 3.3V		20	250	μV/V
REFERENCE						
Output Voltage	V _{REF}	T _A = +25°C	1.237	1.25	1.263	V
Output Voltage Temperature Coefficient	TCV _{REF}	MAX5133A		3		ppm/°C
		MAX5133B		10		
Reference External Load Regulation	V _{OUT} /I _{OUT}	0 ≤ I _{OUT} ≤ 100μA (sourcing)		0.1	1	μV/μA
Reference Short-Circuit Current				4		mA
REFADJ Current		REFADJ = V _{DD}		3.3	7	μA
DIGITAL INPUT						
Input High Voltage	V _{IH}		2.2			V
Input Low Voltage	V _{IL}				0.8	V
Input Hysteresis	V _{HYS}			200		mV

+5V/+3V, 13-Bit, Serial, Force/Sense DACs with 10ppm/°C Internal Reference

ELECTRICAL CHARACTERISTICS—MAX5133 (+3V) (continued)

($V_{DD} = +3V \pm 10\%$, $AGND = DGND$, 33nF capacitor at REFADJ, internal reference, $R_L = 5k\Omega$, $C_L = 100pF$, output amplifier connected in unity-gain, $T_A = T_{MIN}$ to T_{MAX} , unless otherwise noted. Typical values are at $T_A = +25^\circ C$.)

PARAMETER	SYMBOL	CONDITIONS	MIN	TYP	MAX	UNITS
Input Leakage Current	I_{IN}	$V_{IN} = 0$ or V_{DD}	-1	0.001	1	μA
Input Capacitance	C_{IN}			8		pF
DIGITAL OUTPUTS						
Output High Voltage	V_{OH}	$I_{SOURCE} = 2mA$	$V_{DD} - 0.5$			V
Output Low Voltage	V_{OL}	$I_{SINK} = 2mA$		0.13	0.4	V
DYNAMIC PERFORMANCE						
Voltage Output Slew Rate	SR			0.6		V/ μs
Output Settling Time		$T_o \pm 0.5LSB$, $V_{STEP} = 1.25V$		20		μs
Output Voltage Swing (Note 4)			0 to V_{DD}			V
Current into FB			-0.1	0	0.1	μA
Time Required to Exit Shutdown				2		ms
Digital Feedthrough		$\overline{CS} = V_{DD}$, $f_{SCLK} = 100kHz$, $V_{SCLK} = 3Vp-p$		5		nV-s
POWER REQUIREMENTS						
Power-Supply Voltage (Note 5)	V_{DD}		2.7		3.6	V
Power-Supply Current (Note 5)	I_{DD}			500	600	μA
Power-Supply Current in Shutdown	I_{SHDN}			3	20	μA

TIMING CHARACTERISTICS—MAX5132 (+5V)

($V_{DD} = +5V \pm 10\%$, $AGND = DGND$, 33nF capacitor at REFADJ, internal reference, $R_L = 5k\Omega$, $C_L = 100pF$, output amplifier connected in unity-gain, $T_A = T_{MIN}$ to T_{MAX} , unless otherwise noted. Typical values are at $T_A = +25^\circ C$.)

PARAMETER	SYMBOL	CONDITIONS	MIN	TYP	MAX	UNITS
SCLK Clock Period	t_{CP}		100			ns
SCLK Pulse Width High	t_{CH}		40			ns
SCLK Pulse Width Low	t_{CL}		40			ns
\overline{CS} Fall to SCLK Rise Setup Time	t_{CSS}		40			ns
SCLK Rise to \overline{CS} Rise Hold Time	t_{CSH}		0			ns
SDI Setup Time	t_{DS}		40			ns
SDI Hold Time	t_{DH}		0			ns
SCLK Rise to DOUT Valid Propagation Delay Time	t_{DO1}	$C_{LOAD} = 200pF$			80	ns
SCLK Fall to DOUT Valid Propagation Delay Time	t_{DO2}	$C_{LOAD} = 200pF$			80	ns
SCLK Rise to \overline{CS} Fall Delay Time	t_{CS0}		10			ns
\overline{CS} Rise to SCLK Rise Hold Time	t_{CS1}		40			ns
\overline{CS} Pulse Width High	t_{CSW}		100			ns

+5V/+3V, 13-Bit, Serial, Force/Sense DACs with 10ppm/°C Internal Reference

MAX5132/MAX5133

TIMING CHARACTERISTICS—MAX5133 (+3V)

($V_{DD} = +3V \pm 10\%$, $AGND = DGND$, 33nF capacitor at REFADJ, internal reference, $R_L = 5k\Omega$, $C_L = 100pF$, output amplifier connected in unity-gain, $T_A = T_{MIN}$ to T_{MAX} , unless otherwise noted. Typical values are at $T_A = +25^\circ C$.)

PARAMETER	SYMBOL	CONDITIONS	MIN	TYP	MAX	UNITS
SCLK Clock Period	tCP		150			ns
SCLK Pulse Width High	tCH		75			ns
SCLK Pulse Width Low	tCL		75			ns
\overline{CS} Fall to SCLK Rise Setup Time	tCSS		60			ns
SCLK Rise to \overline{CS} Rise Hold Time	tCSH		0			ns
SDI Setup Time	tDS		60			ns
SDI Hold Time	tDH		0			ns
SCLK Rise to DOUT Valid Propagation-Delay Time	tDO1	$C_{LOAD} = 200pF$			200	ns
SCLK Fall to DOUT Valid Propagation-Delay Time	tDO2	$C_{LOAD} = 200pF$			200	ns
SCLK Rise to \overline{CS} Fall Delay Time	tCS0		10			ns
\overline{CS} Rise to SCLK Rise Hold Time	tCS1		75			ns
\overline{CS} Pulse Width High	tCSW		150			ns

Note 1: Accuracy is guaranteed by following the table:

V_{DD} (V)	Accuracy Guaranteed	
	From Code:	To Code:
5	32	8191
3	65	8191

Note 2: Offset is measured at the code closest to 10mV.

Note 3: The temperature coefficient is determined by the “box” method in which the maximum ΔV_{OUT} over the temperature range is divided by ΔT and the typical reference voltage.

Note 4: Accuracy is better than 1.0LSB for $V_{OUT} = 10mV$ to $V_{DD} - 180mV$. Guaranteed by PSR test on end points.

Note 5: $R_{LOAD} = \infty$ and digital inputs are at either V_{DD} or $DGND$.

+5V/+3V, 13-Bit, Serial, Force/Sense DACs with 10ppm/°C Internal Reference

Typical Operating Characteristics

($V_{DD} = +5V$, $R_L = 5k\Omega$, $C_L = 100pF$, OS = AGND, $T_A = +25^\circ C$, output amplifier connected in unity-gain configuration, unless otherwise noted.)

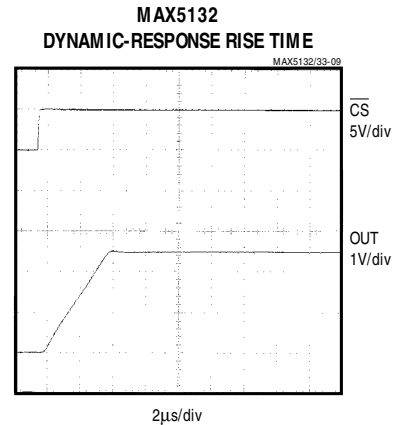
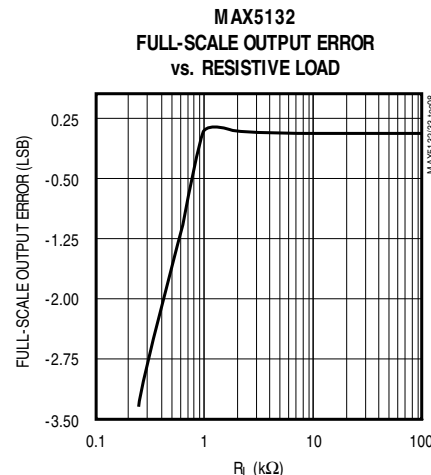
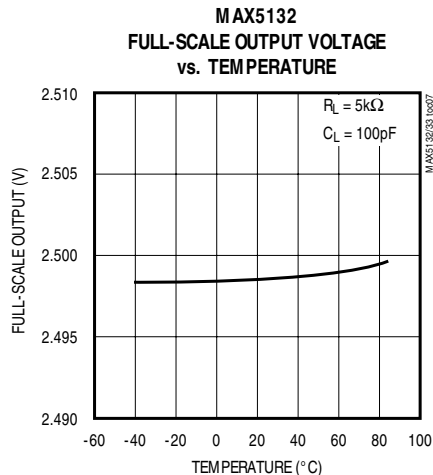
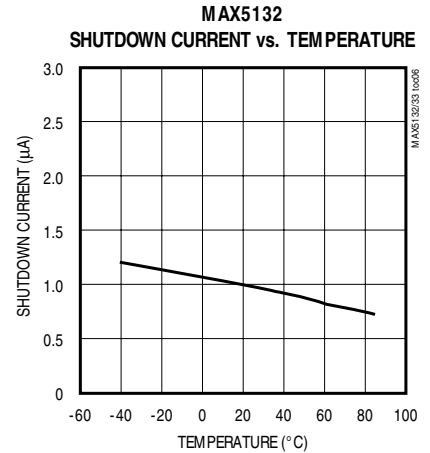
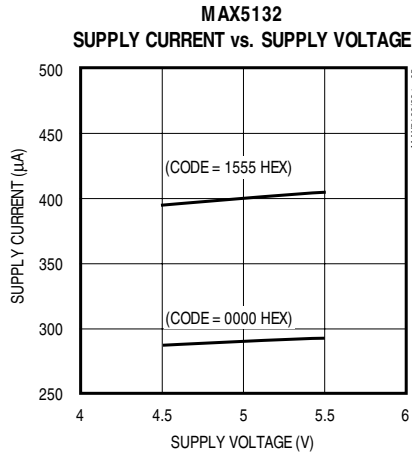
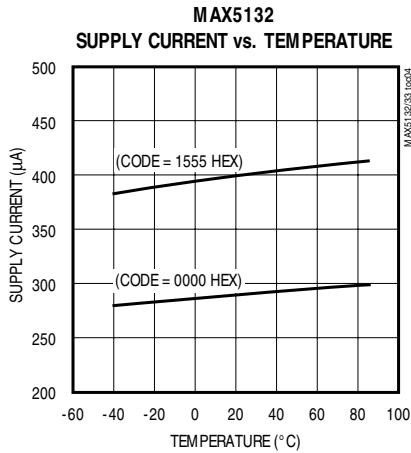
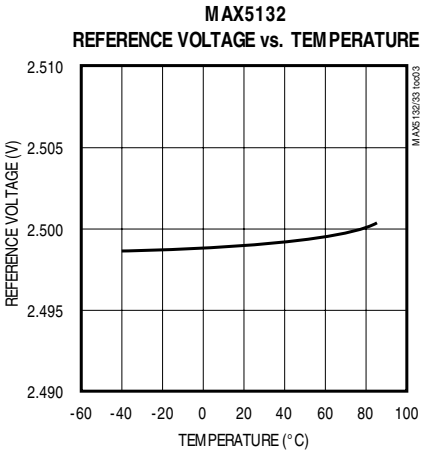
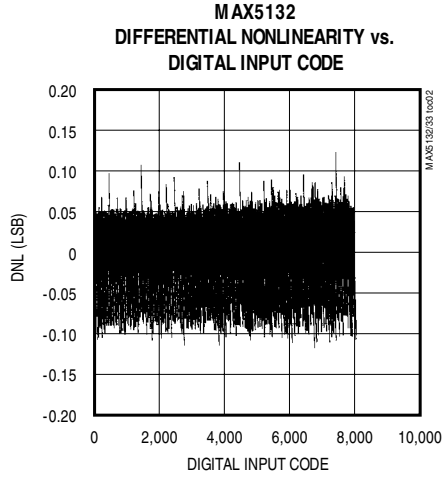
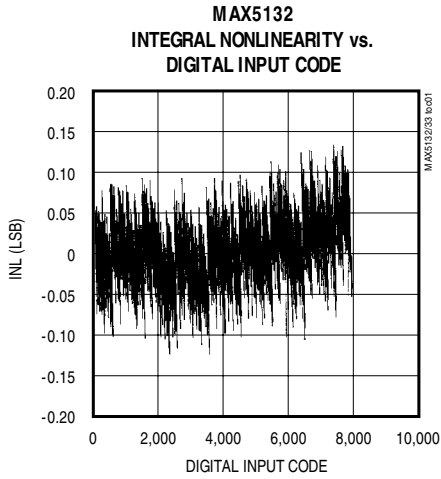

+5V/+3V, 13-Bit, Serial, Force/Sense DACs with 10ppm/°C Internal Reference

Typical Operating Characteristics (continued)

($V_{DD} = +5V$, $R_L = 5k\Omega$, $C_L = 100pF$, $OS = AGND$, $T_A = +25^\circ C$, output amplifier connected in unity-gain configuration, unless otherwise noted.)

MAX5132/MAX5133

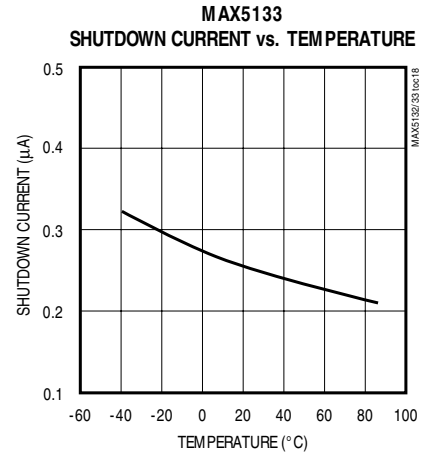
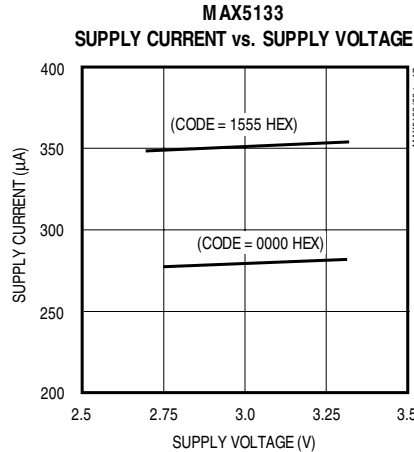
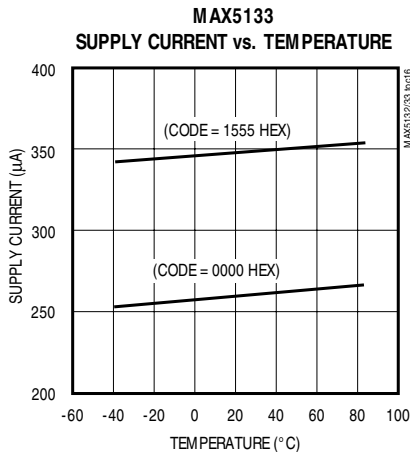
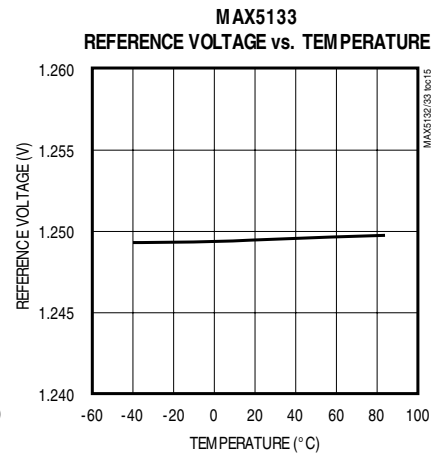
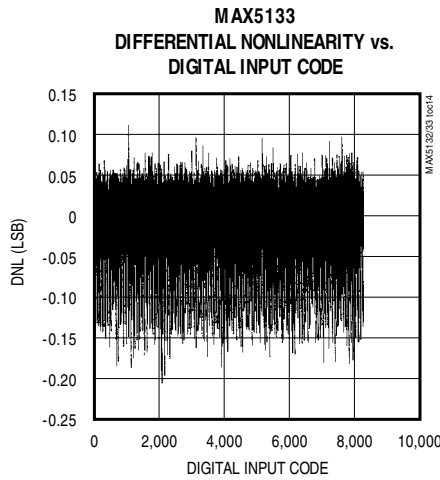
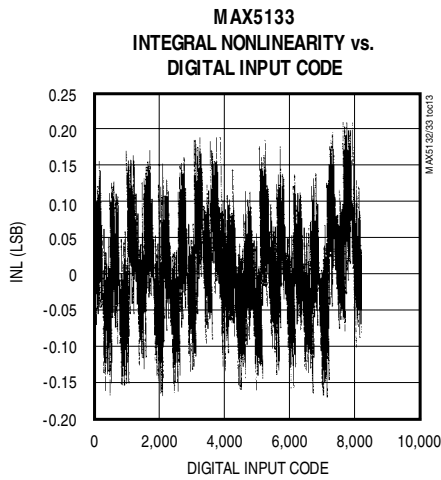
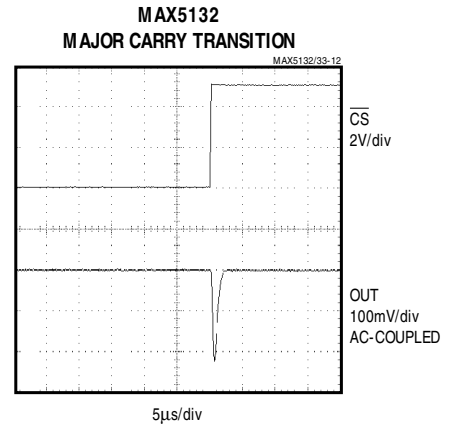
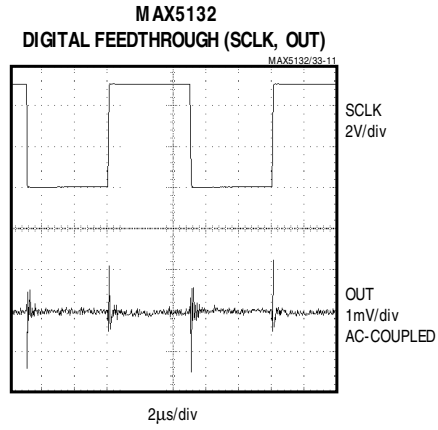
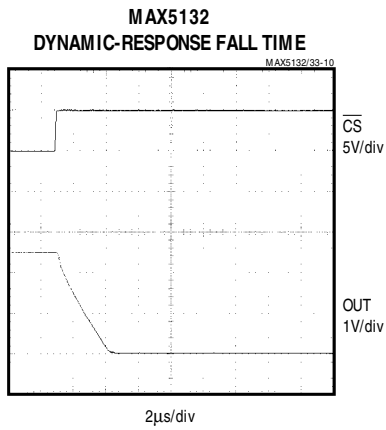

+5V/+3V, 13-Bit, Serial, Force/Sense DACs with 10ppm/°C Internal Reference

Typical Operating Characteristics (continued)

(V_{DD} = +5V, R_L = 5kΩ, C_L = 100pF, OS = AGND, T_A = +25°C, output amplifier connected in unity-gain configuration, unless otherwise noted.)

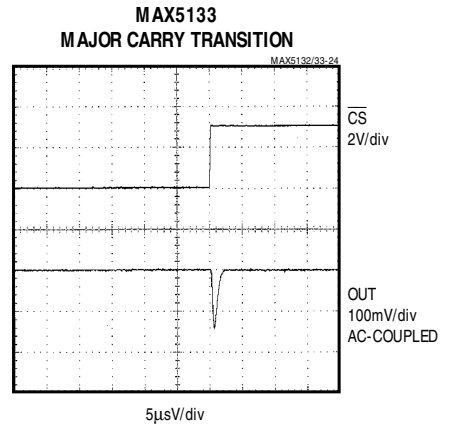
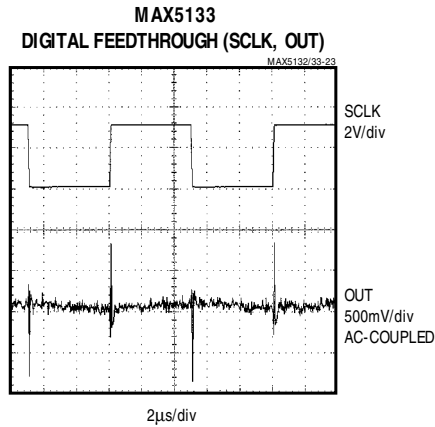
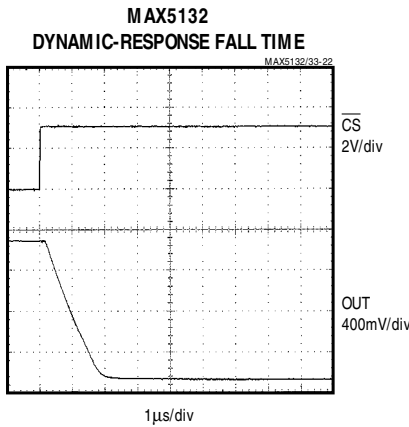
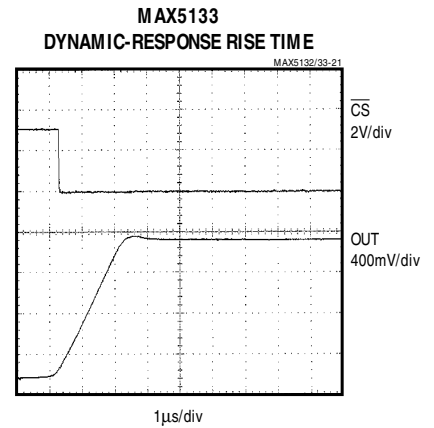
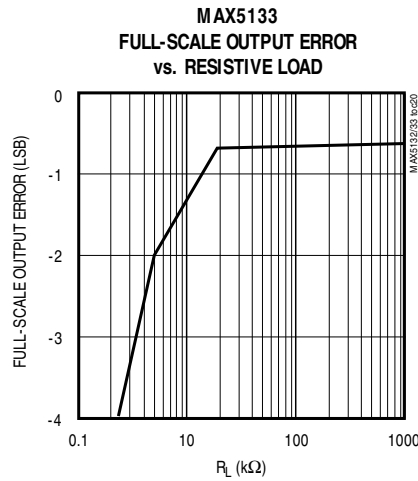
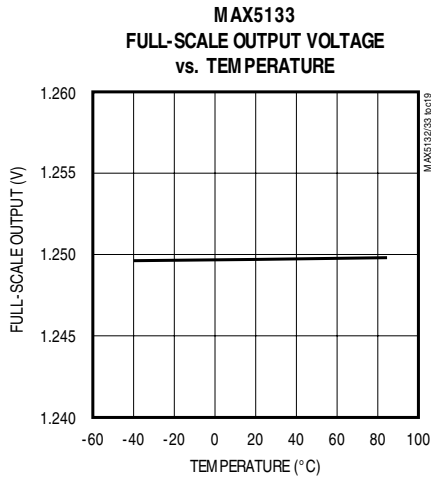

+5V/+3V, 13-Bit, Serial, Force/Sense DACs with 10ppm/°C Internal Reference

Pin Description

MAX5132/MAX5133

PIN	NAME	FUNCTION
1	FB	Amplifier Inverting Sense Input (Analog Input)
2	OUT	Analog Output Voltage. High impedance if part is in shutdown.
3	RSTVAL	Reset Value Input (Digital Input) 1: Connect to VDD to select midscale as the output reset value. 0: Connect to DGND to select 0V as the output reset value.
4	$\overline{\text{PDL}}$	Power-Down Lockout (Digital Input). 1: Normal operation. 0: Disallows shutdown (device cannot be powered down).
5	$\overline{\text{CLR}}$	Reset DAC Input (Digital Input). Clears the DAC to its predetermined (RSTVAL) output state. Clearing the DAC will cause it to exit a software shutdown state.
6	$\overline{\text{CS}}$	Active-Low Chip-Select Input (Digital Input)
7	DIN	Serial Data Input. Data is clocked in on the rising edge of SCLK.
8	SCLK	Serial Clock Input
9	DGND	Digital Ground
10	DOUT	Serial Data Output
11	UPO	User-Programmable Output (Digital Output)
12	PD	Power-Down Input (Digital Input). Pulling PD high when PDL = VDD places the IC into shutdown with a maximum shutdown current of 20 μ A.
13	AGND	Analog Ground
14	REF	Buffered Reference Output/Input. In internal reference mode, the reference buffer provides a +2.5V (MAX5132) or +1.25V (MAX5133) nominal output, externally adjustable at REFADJ. In external reference mode, disable the internal reference by pulling REFADJ to VDD and applying the external reference to REF.
15	REFADJ	Analog Reference Adjust Input. Bypass with a 33nF capacitor to AGND. Connect to VDD when using an external reference.
16	VDD	Positive Power Supply. Bypass with a 0.1 μ F capacitor in parallel with a 4.7 μ F capacitor to AGND.

+5V/+3V, 13-Bit, Serial, Force/Sense DACs with 10ppm/°C Internal Reference

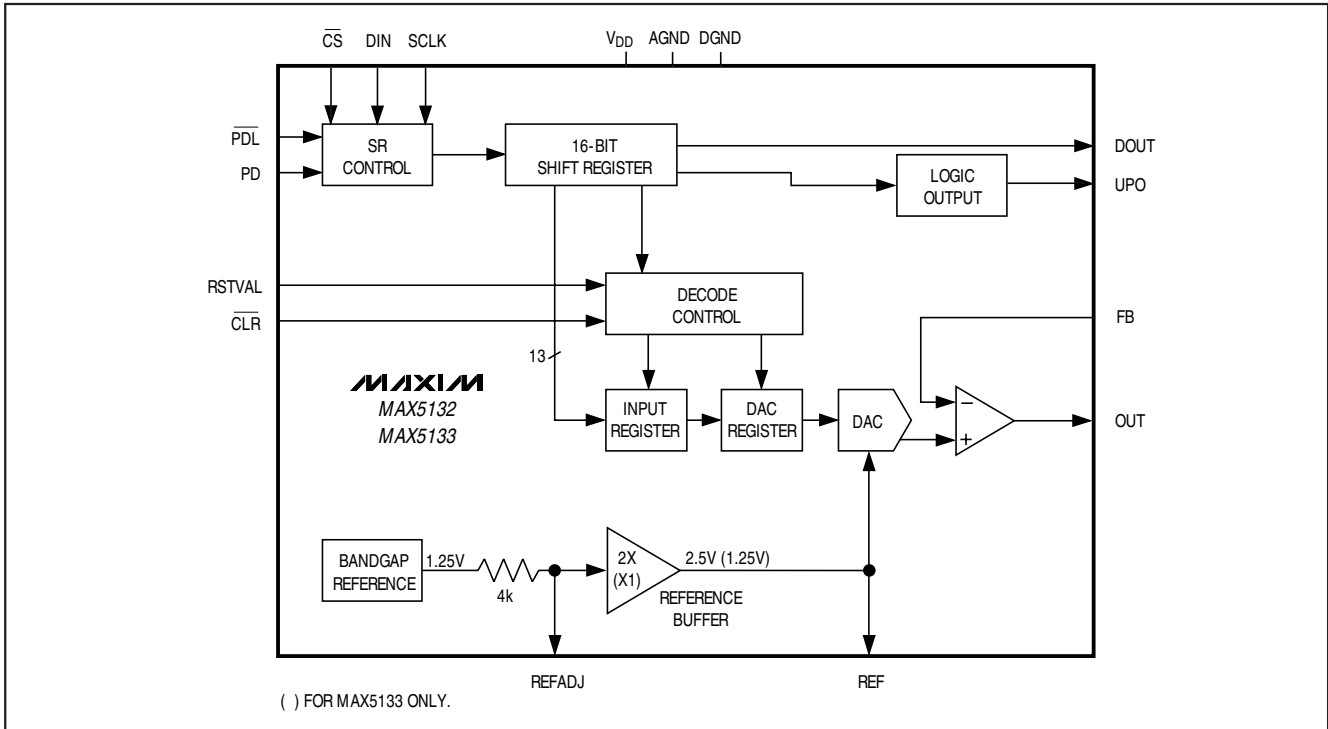

Figure 1. Simplified Functional Diagram

Detailed Description

The MAX5132/MAX5133 13-bit, force/sense DACs are easily configured with a 3-wire serial interface. They include a 16-bit data-in/data-out shift register and have a double-buffered digital input consisting of an input register and a DAC register. In addition, these devices employ precision bandgap references, as well as an output amplifier with accessible feedback and output pins that can be used for setting the gain externally (Figure 1) or for forcing and sensing applications. These DACs are designed with an inverted R-2R ladder network (Figure 2) that produces a weighted voltage proportional to the digital input code.

Internal Reference

Both devices use an on-board precision bandgap reference with a low temperature coefficient of only 10ppm/°C (max) to generate an output voltage of +2.5V (MAX5132) or +1.25V (MAX5133). The REF pin can source up to 100µA and may become unstable with capacitive loads exceeding 100pF. REFADJ can be used for minor adjustments to the reference voltage. The circuits in Figures 3a and 3b achieve a nominal reference adjustment range of ±1%. Connect a 33nF capacitor from REFADJ to AGND to establish low-noise

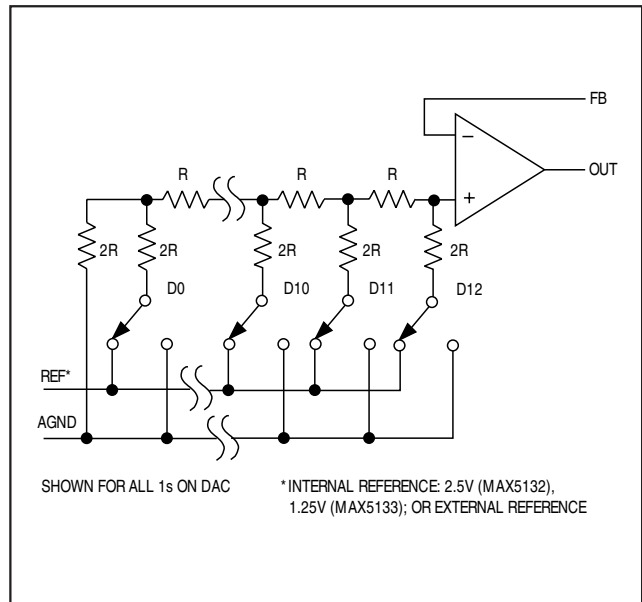

Figure 2. Simplified Inverted R-2R DAC Structure

+5V/+3V, 13-Bit, Serial, Force/Sense DACs with 10ppm/°C Internal Reference

operation of the DAC. Larger capacitor values may be used but will result in increased start-up delay. The time constant τ for the start-up delay is determined by the REFADJ input impedance of $4k\Omega$ and C_{REFADJ} :

$$\tau = 4k\Omega \cdot C_{REFADJ}$$

External Reference

An external reference may be applied to the REF pin. Disable the internal reference by pulling REFADJ to V_{DD} . This allows an external reference signal (AC- or DC-based) to be fed into the REF pin. For proper operation, **do not** exceed the input voltage range limits of 0V to $(V_{DD} - 1.4V)$ for V_{REF} .

Determine the output voltage using the following equation ($REFADJ = V_{DD}$):

$$V_{OUT} = V_{REF}(NB / 8192)G$$

where NB is the numeric value of the MAX5132/MAX5133 input code (0 to 8191), V_{REF} is the external reference voltage, and G is the gain of the output amplifier, set by an external resistor-divider. The REF pin has a minimum input resistance of $40k\Omega$ and is code dependent.

Output Amplifier

The MAX5132/MAX5133's DAC output is internally buffered by a precision amplifier with a typical slew rate of $0.6V/\mu s$. Access to the output amplifier's inverting input (FB) provides the user greater flexibility with amplifier gain setting and signal conditioning (see *Applications Information*).

The output amplifier typically settles to $\pm 0.5LSB$ from a full-scale transition within $20\mu s$ when it is connected in

unity gain and loaded with $5k\Omega \parallel 100pF$. Loads less than $1k\Omega$ may result in degraded performance.

Power-Down Mode

The MAX5132/MAX5133 feature software- and hardware-programmable (PD pin) shutdown modes that reduce the typical supply current to $3\mu A$. To enter software shutdown mode, program the control sequence for the DAC as shown in Table 1.

In shutdown mode, the amplifier output becomes high impedance and the serial interface remains active. Data in the input registers is saved, allowing the MAX5132/MAX5133 to recall the output state prior to entering shutdown when returning to normal operation. To exit shutdown mode, load both input and DAC registers simultaneously or update the DAC register from the input register. When returning from shutdown to normal operation, wait 2ms for the reference to settle. When using an external reference, the DAC requires only $20\mu s$ for the output to stabilize.

Power-Down Lockout Input (PDL)

The power-down lockout (\overline{PDL}) pin disables shutdown when low. When in shutdown mode, a high-to-low transition on \overline{PDL} will wake up the DAC with its output still set to the state prior to power-down. \overline{PDL} can also be used to wake up the device asynchronously.

Power-Down Input (PD)

Pulling PD high places the MAX5132/MAX5133 in shutdown. Pulling PD low will not return the MAX5132/MAX5133 to normal operation. A high-to-low transition on \overline{PDL} or appropriate commands (Table 1) via the serial interface are required to exit power-down.

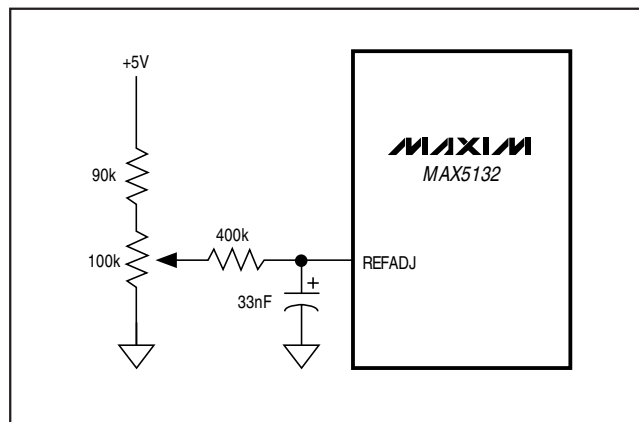

Figure 3a. MAX5132 Reference Adjust Circuit

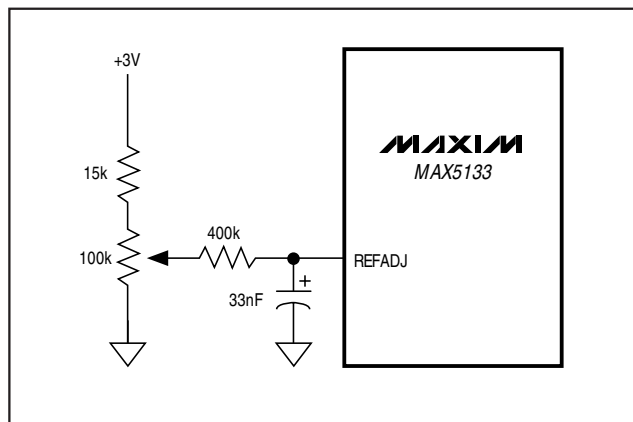

Figure 3b. MAX5133 Reference Adjust Circuit

+5V/+3V, 13-Bit, Serial, Force/Sense DACs with 10ppm/°C Internal Reference

Table 1. Serial-Interface Programming Commands

16-BIT SERIAL WORD				FUNCTION
C2	C1	C0	D12 D0	
0	0	0	XXXXXXXXXXXX	No operation.
0	0	1	13-Bit DAC Data	Load input register; DAC register unchanged.
0	1	0	13-Bit DAC Data	Simultaneously load input and DAC registers; exit shutdown.
0	1	1	XXXXXXXXXXXX	Update DAC register from input register; exit shutdown.
1	0	1	XXXXXXXXXXXX	Shutdown DAC (provided $\overline{PDL} = 1$).
1	0	0	XXXXXXXXXXXX	UPO goes low (default).
1	1	0	XXXXXXXXXXXX	UPO goes high.
1	1	1	1XXXXXXXXXXXX	Mode 1: DOUT clocked out on SCLK's rising edge.
1	1	1	0XXXXXXXXXXXX	Mode 0: DOUT clocked out on SCLK's falling edge (default).

X = Don't care

Serial-Interface Configuration (SPI/QSPI/MICROWIRE/PIC16/PIC17)

The MAX5132/MAX5133 3-wire serial interface is compatible with SPI, QSPI, PIC16/PIC17 (Figure 4) and MICROWIRE (Figure 5) interface standards. The 2-byte-long serial input word contains three control bits and 13 data bits in MSB-first format (Table 2).

The MAX5132/MAX5133's digital inputs are double buffered, which allows the user to:

- load the input register without updating the DAC register,
- update the DAC register with data from the input register,
- update the input and DAC registers concurrently.

The 16-bit input word may be sent in two 1-byte packets (SPI-, MICROWIRE- and PIC16/PIC17-compatible), with \overline{CS} low during this period. The control bits C2, C1, and C0 (Table 1) determine:

- the clock edge on which DOUT transitions,
- the state of the user-programmable logic output,
- the configuration of the device after shutdown.

The general timing diagram in Figure 6 illustrates how data is acquired. \overline{CS} must be low for the part to receive data. With \overline{CS} low, data at DIN is clocked into the register on the rising edge of SCLK. When \overline{CS} transitions high, data is latched into the input and/or DAC registers, depending on the setting of the three control bits C2, C1, and C0. The maximum serial-clock frequency guaranteed for proper operation is 10MHz for the MAX5132 and 6.6MHz for the MAX5133. Figure 7 depicts a more detailed timing diagram of the serial interface.

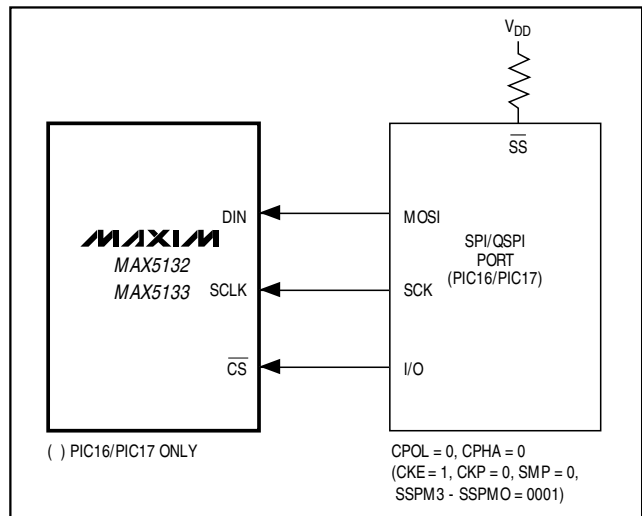

Figure 4. SPI/QSPI Interface Connections (PIC16/PIC17)

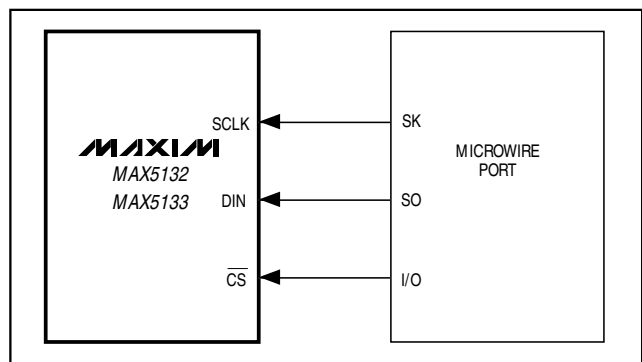

Figure 5. MICROWIRE Interface Connections

+5V/+3V, 13-Bit, Serial, Force/Sense DACs with 10ppm/°C Internal Reference

PIC16 with SSP Module and PIC17 Interface

The MAX5132/MAX5133 are compatible with a PIC16/PIC17 microcontroller (μ C), using the synchronous serial port (SSP) module. To establish SPI communication, connect the controller as shown in Figure 4 and configure the PIC16/PIC17 as system master by initializing its synchronous serial-port control register (SSPCON) and synchronous serial-port status register (SSPSTAT) to the bit patterns shown in Tables 3 and 4.

In SPI mode, the PIC16/PIC17 μ Cs allow eight bits of data to be synchronously transmitted and received simultaneously. Two consecutive 8-bit writings (Figure 6) are necessary to feed the DAC with three control bits and 13 data bits. DIN data transitions on the serial clock's falling edge and is clocked into the DAC on SCLK's rising edge. The first eight bits of DIN contain

the three control bits (C2, C1, C0) and the first five data bits (D12–D8). The second 8-bit data stream contains the remaining bits, D7–D0.

Serial Data Output

The contents of the internal shift-register are output serially on DOUT, which allows for daisy-chaining (see *Applications Information*) of multiple devices as well as data readback. The MAX5132/MAX5133 may be programmed to shift data out of DOUT on the serial clock's rising edge (Mode 1) or on the falling edge (Mode 0). The latter is the default during power-up and provides a lag of 16 clock cycles, maintaining SPI, QSPI, MICROWIRE, and PIC16/PIC17 compatibility. In Mode 1, the output data lags DIN by 15.5 clock cycles. During power-down, DOUT retains its last digital state prior to shutdown.

User-Programmable Output (UPO)

The UPO feature allows an external device to be controlled through the serial-interface setup (Table 1), thereby reducing the number of microcontroller I/O ports required. During power-down, this output will retain the last digital state before shutdown. With $\overline{\text{CLR}}$ pulled low, UPO will reset to the default state after wake-up.

Table 2. Serial Data Format

MSB		LSB	
← 16 BITS OF SERIAL DATA →			
Control Bits	MSB	Data Bits	LSB
C2, C1, C0	D12.....D0		

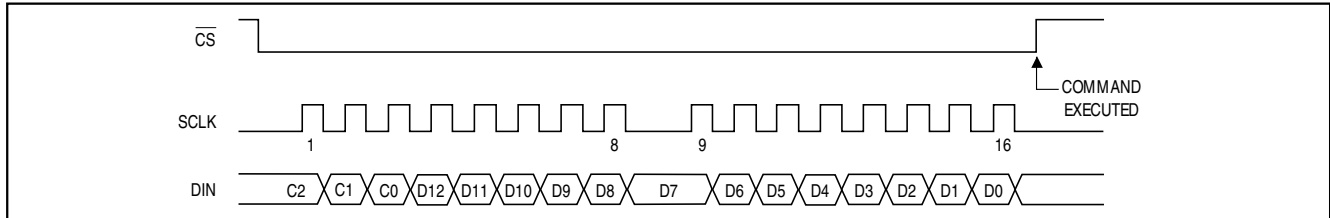

Figure 6. Serial-Interface Timing

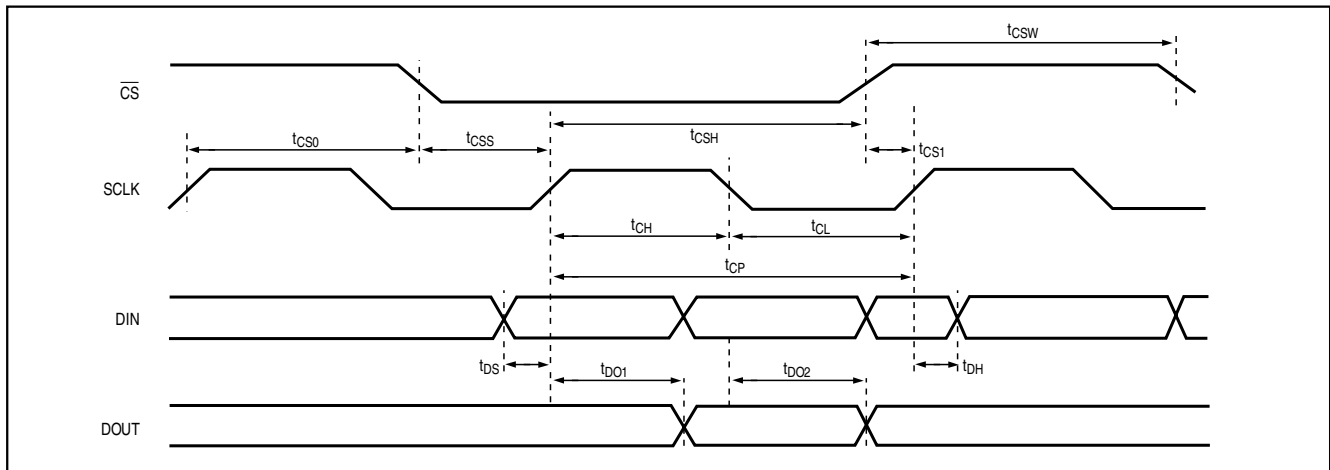

Figure 7. Detailed Serial-Interface Timing

+5V/+3V, 13-Bit, Serial, Force/Sense DACs with 10ppm/°C Internal Reference

Table 3. Detailed SSPCON Register Contents

CONTROL BIT		MAX5132/MAX5133 SETTINGS	SYNCHRONOUS SERIAL-PORT CONTROL REGISTER (SSPCON)
WCOL	BIT7	X	Write-Collision Detection Bit
SSPOV	BIT6	X	Receive-Overflow Detection Bit
SSPEN	BIT5	1	Synchronous Serial Port Enable Bit 0: Disables serial port and configures these pins as I/O port pins. 1: Enables serial port and configures SCK, SDO, and SCI as serial-port pins.
CKP	BIT4	0	Clock-Polarity Select Bit. CKP = 0 for SPI master-mode selection.
SSPM3	BIT3	0	Synchronous Serial-Port Mode Select Bit. Sets SPI master mode and selects $f_{CLK} = f_{OSC} / 16$.
SSPM2	BIT2	0	
SSPM1	BIT1	0	
SSPM0	BIT0	1	

X = Don't care

Table 4. Detailed SSPSTAT Register Contents

CONTROL BIT		MAX5132/MAX5133 SETTINGS	SYNCHRONOUS SERIAL-PORT STATUS REGISTER (SSPSTAT)
SMP	BIT7	0	SPI Data-Input Sample Phase. Input data is sampled at the middle of the data-output time.
CKE	BIT6	1	SPI Clock-Edge Select Bit. Data will be transmitted on the rising edge of the serial clock.
D/A	BIT5	X	Data-Address Bit
P	BIT4	X	Stop Bit
S	BIT3	X	Start Bit
R/W	BIT2	X	Read/Write Bit Information
UA	BIT1	X	Update Address
BF	BIT0	X	Buffer Full-Status Bit

X = Don't care

Applications Information

Definitions

Integral Nonlinearity (INL)

Integral nonlinearity (Figure 8a) is the deviation of the values on an actual transfer function from a straight line. This straight line can be either a best-straight-line fit (closest approximation to the actual transfer curve) or a line drawn between the endpoints of the transfer function, once offset and gain errors have been nullified. For a DAC, the deviations are measured at every single step.

Differential Nonlinearity (DNL)

Differential nonlinearity (Figure 8b) is the difference between an actual step height and the ideal value of 1LSB. If the magnitude of the DNL is less than or equal to 1LSB, the DAC guarantees no missing codes and is monotonic.

Offset Error

The offset error (Figure 8c) is the difference between the ideal and the actual offset point. For a DAC, the offset point is the step value when the digital input is zero. This error affects all codes by the same amount and can usually be compensated for by trimming.

+5V/+3V, 13-Bit, Serial, Force/Sense DACs with 10ppm/°C Internal Reference

Gain Error

Gain error (Figure 8d) is the difference between the ideal and the actual full-scale output voltage on the transfer curve, after nullifying the offset error. This error alters the slope of the transfer function and corresponds to the same percentage error in each step.

Settling Time

The settling time is the amount of time required from the start of a transition until the DAC output settles to its new output value within the converter's specified accuracy.

Digital Feedthrough

Digital feedthrough is noise generated on the DAC's output when any digital input transitions. Proper board layout and grounding will significantly reduce this noise, but there will always be some feedthrough caused by the DAC itself.

Unipolar Output

Figure 9 shows the MAX5132/MAX5133 setup for unipolar, Rail-to-Rail™ operation with a closed-loop gain of 2V/V. With its internal reference of +2.5V, the MAX5132 provides a convenient unipolar output range of 0 to +4.99939V, while the MAX5133 offers an output range of 0 to +2.499695V with its on-board +1.25V reference. Table 5 lists example codes for unipolar output voltages.

Bipolar Output

The MAX5132/MAX5133 can be configured for unity-gain bipolar operation (FB = OUT) using the circuit shown in Figure 10. The output voltage V_{OUT} is then given by the following equation:

$$V_{OUT} = V_{REF} [G (NB / 8192) - 1]$$

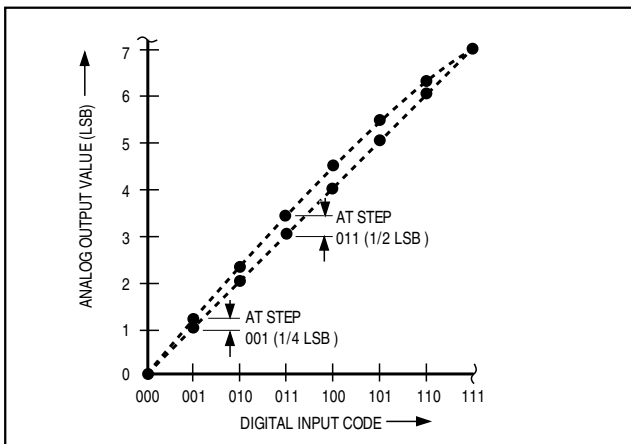

Figure 8a. Integral Nonlinearity

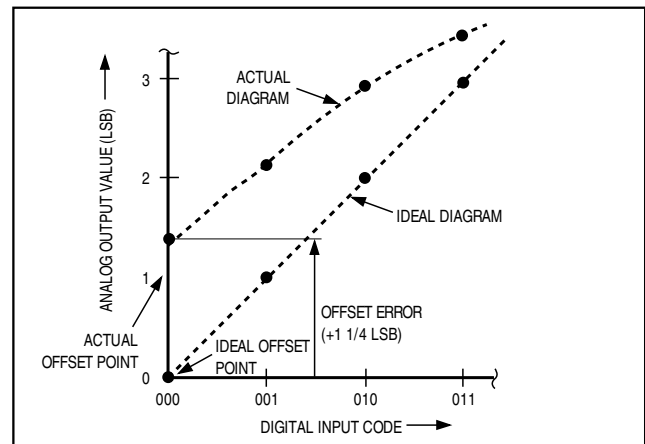

Figure 8c. Offset Error

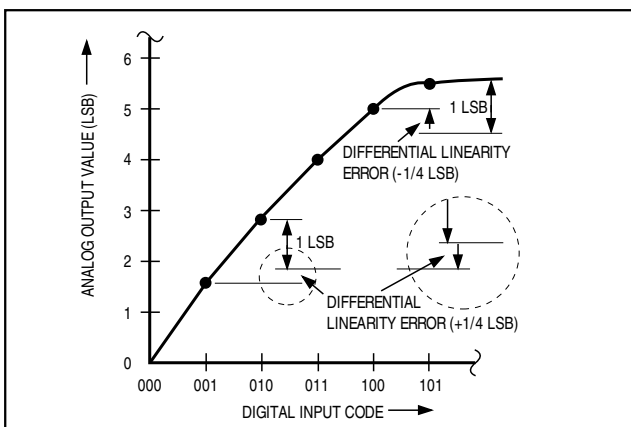

Figure 8b. Differential Nonlinearity

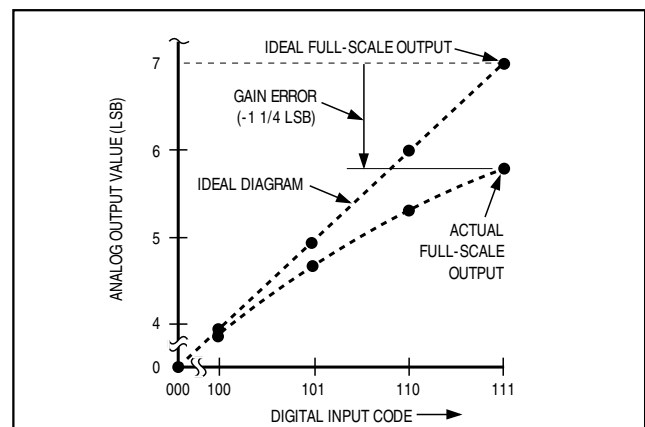

Figure 8d. Gain Error

Rail-to-Rail is a registered trademark of Nippon Motorola, Ltd.

+5V/+3V, 13-Bit, Serial, Force/Sense DACs with 10ppm/°C Internal Reference

where NB is the numeric value of the DAC's binary input code, V_{REF} is the voltage of the internal (or external) precision reference, and G is the overall gain. The application circuit in Figure 10 uses a low-cost op amp (MAX4162) external to the MAX5132/MAX5133. Together with the MAX5132/MAX5133, this circuit offers an overall gain of 2V/V. Table 6 lists example codes for bipolar output voltages.

Reset (RSTVAL) and Clear (CLR) Functions

The MAX5132/MAX5133 DACs feature a clear pin (\overline{CLR}), which resets the output to a certain value, depending upon how RSTVAL is set. RSTVAL = DGND selects an output of 0, and RSTVAL = V_{DD} selects a midscale output when \overline{CLR} is pulled low.

The \overline{CLR} pin has a minimum input resistance of 40k Ω in series with a diode to the supply voltage (V_{DD}). If the digital voltage is higher than the supply voltage for the part, a small input current may flow, but this current will be limited to $(V_{\overline{CLR}} - V_{DD} - 0.5V) / 40k\Omega$.

Note: Clearing the DAC will also cause the part to exit software shutdown (PD = 0).

Daisy-Chaining Devices

Any number of MAX5132/MAX5133s may be daisy-chained simply by connecting the serial data output pin (DOUT) of one device to the serial data input pin (DIN) of the following device in the chain (Figure 11).

Another configuration (Figure 12) allows several MAX5132/MAX5133 DACs to share one common DIN signal line. In this configuration, the data bus is common to all devices; data is not shifted through a daisy chain. However, more I/O lines are required in this configuration because each IC needs a dedicated \overline{CS} line.

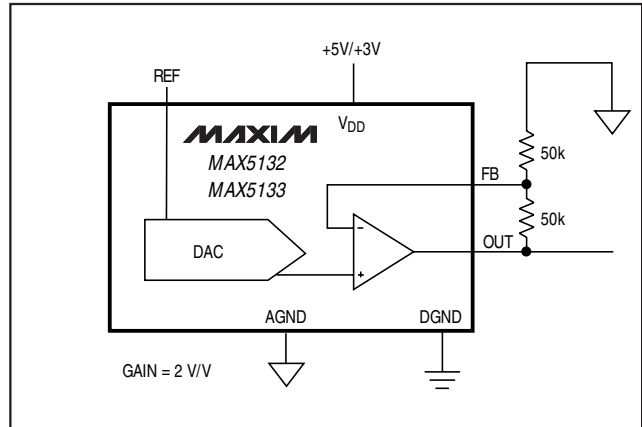

Figure 9. Unipolar Output Circuit Using Internal (+1.25V/+2.5V) or External Reference. With external reference, pull REFADJ to V_{DD} .

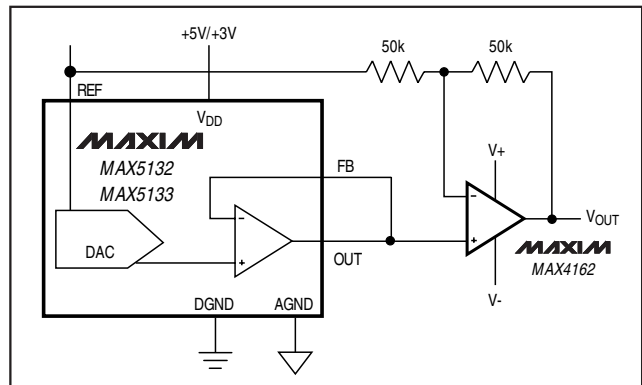

Figure 10. Unity-Gain Bipolar Output Circuit Using Internal (+1.25V/+2.5V) or External Reference. With external reference, pull REFADJ to V_{DD} .

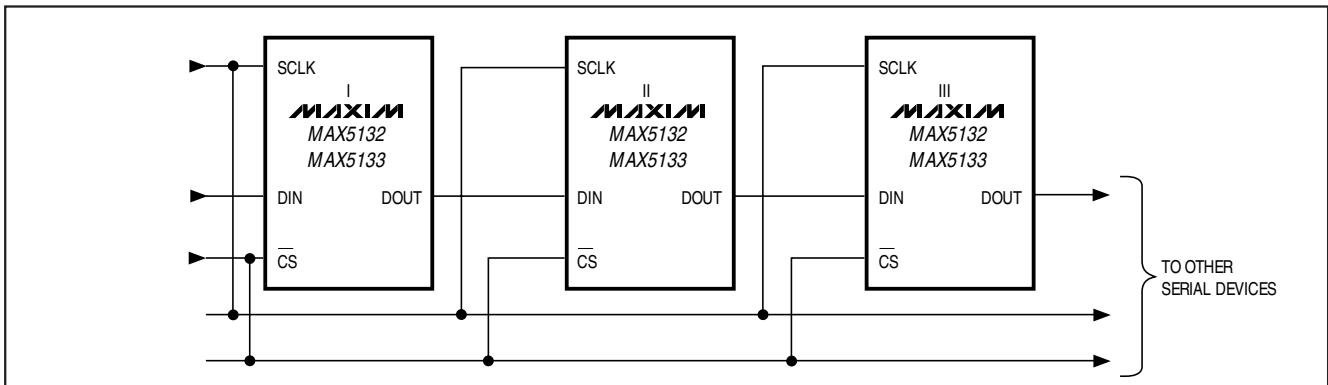

Figure 11. Daisy-Chaining Multiple Devices with the Digital I/Os DIN/DOUT

+5V/+3V, 13-Bit, Serial, Force/Sense DACs with 10ppm/°C Internal Reference

MAX5132/MAX5133

Table 5. Unipolar Code Table (Gain = +2V/V)

DAC CONTENTS		ANALOG OUTPUT		
MSB	LSB	INTERNAL REFERENCE		EXTERNAL REFERENCE
		MAX5132	MAX5133	MAX5132/MAX5133
1	1111 1111 1111	4.99939V	2.49969V	$V_{REF} (8191 / 8192) \cdot 2$
1	0000 0000 0001	2.50061V	1.25031V	$V_{REF} (4097 / 8192) \cdot 2$
1	0000 0000 0000	2.5V	1.25V	$V_{REF} (4096 / 8192) \cdot 2$
0	1111 1111 1111	2.49939V	1.24969V	$V_{REF} (4095 / 8192) \cdot 2$
0	0000 0000 0001	610.35μV	305.18μV	$V_{REF} (1 / 8192) \cdot 2$
0	0000 0000 0000	0V	0V	0V

Table 6. Bipolar Code Table for Figure 10

DAC CONTENTS		ANALOG OUTPUT		
MSB	LSB	INTERNAL REFERENCE		EXTERNAL REFERENCE
		MAX5132	MAX5133	MAX5132/MAX5133
1	1111 1111 1111	2.49939V	1.24969V	$V_{REF} [2 (8191 / 8192) - 1]$
1	1000 0000 0001	610.35μV	305.18μV	$V_{REF} [2 (4097 / 8192) - 1]$
1	1000 0000 0000	0V	0V	$V_{REF} [2 (4096 / 8192) - 1]$
0	1111 1111 1111	-610.35μV	-305.18μV	$V_{REF} [2 (4095 / 8192) - 1]$
0	0000 0000 0001	-2.49939V	-1.24969V	$V_{REF} [2 (1 / 8192) - 1]$
0	0000 0000 0000	-2.5V	-1.25V	-V _{REF}

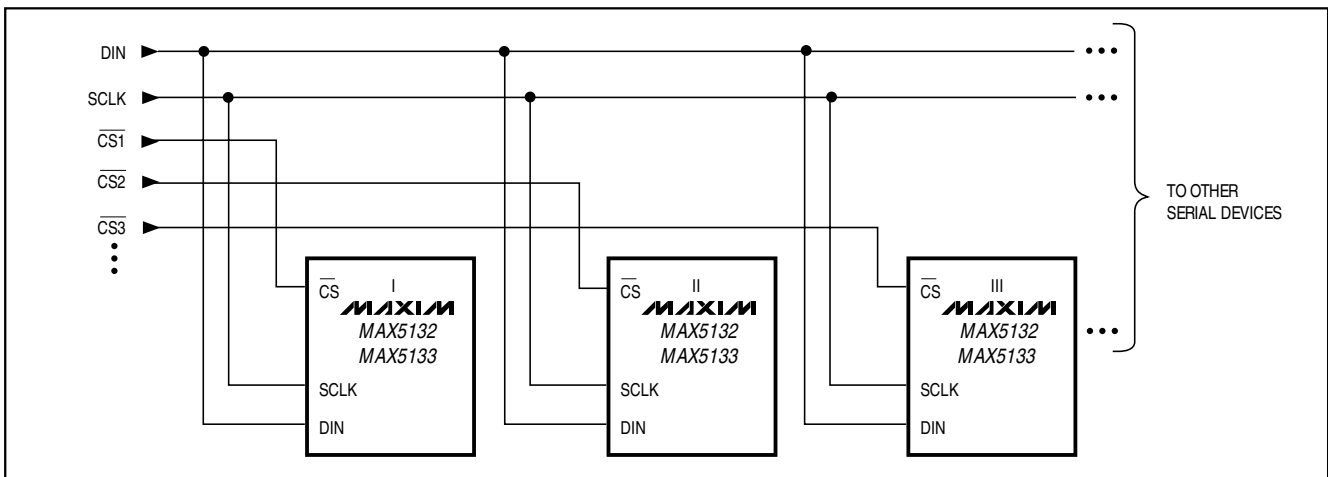

Figure 12. Multiple Devices Share One Common Digital Input (DIN)

+5V/+3V, 13-Bit, Serial, Force/Sense DACs with 10ppm/°C Internal Reference

Using an External Reference with AC Components

The MAX5132/MAX5133 have multiplying capabilities within the reference input voltage range specifications. Figure 13 shows a technique for applying a sinusoidal input to REF, where the AC signal is offset before being applied to the reference input.

Power-Supply and Bypassing Considerations

On power-up, the input and DAC registers are cleared to either zero (RSTVAL = DGND) or midscale (RSTVAL = VDD). Bypass the power supply (VDD) with a 4.7μF

capacitor in parallel with a 0.1μF capacitor to AGND. Minimize lead lengths to reduce lead inductance.

Layout Considerations

Digital and AC signals coupling to AGND can create noise at the output. Connect AGND to the highest quality ground available. Use proper grounding techniques, such as a multilayer board with a low-inductance ground plane. Wire-wrapped boards and sockets are not recommended. If noise becomes an issue, shielding may be required.

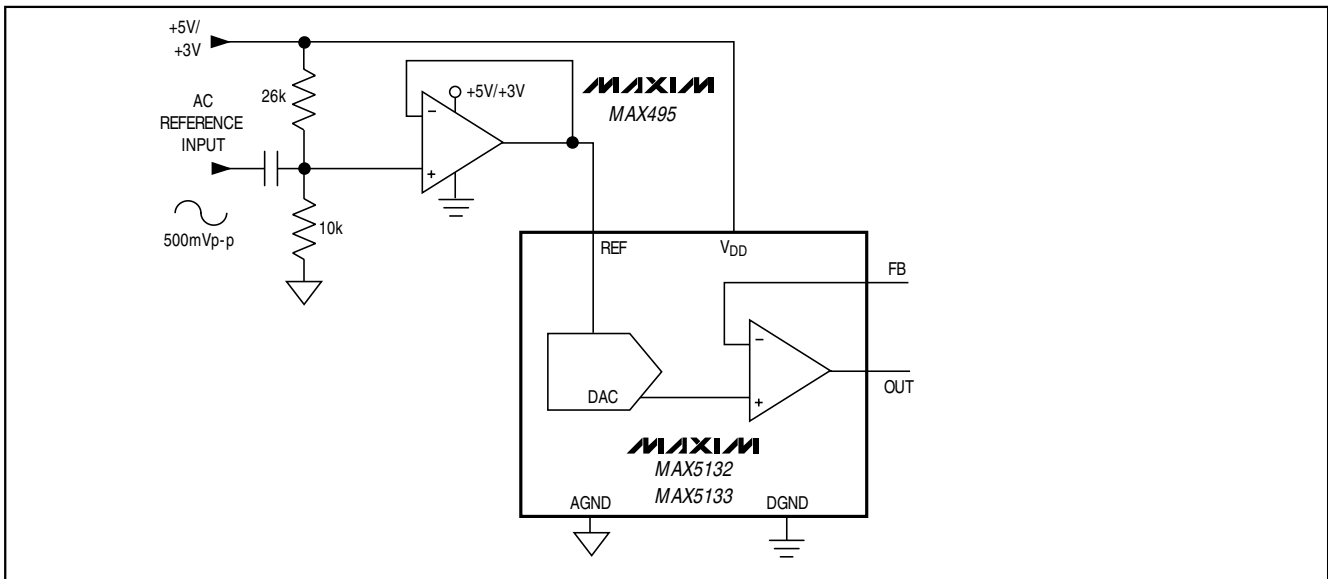

Figure 13. External Reference with AC Components

Chip Information

TRANSISTOR COUNT: 3308
SUBSTRATE CONNECTED TO AGND.

+5V/+3V, 13-Bit, Serial, Force/Sense DACs with 10ppm/°C Internal Reference

Package Information

MAX5132/MAX5133

QSOP-EPS

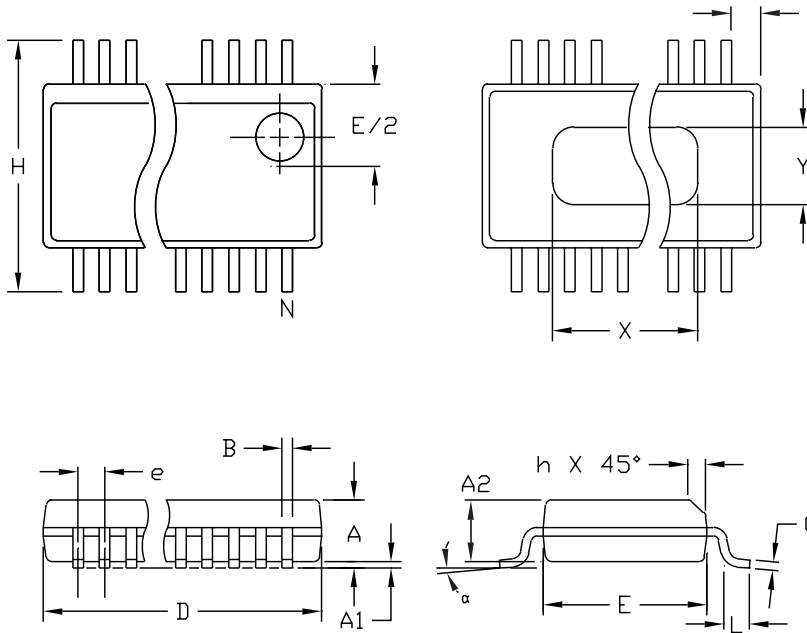

DIM	INCHES		MILLIMETERS	
	MIN	MAX	MIN	MAX
A	.061	.068	1.55	1.73
A1	.004	.0098	0.102	0.249
A2	.055	.061	1.40	1.55
B	.008	.012	0.20	0.31
C	.0075	.0098	0.191	0.249
D	SEE VARIATIONS			
E	.150	.157	3.81	3.99
e	.025 BSC		0.635 BSC	
H	.230	.244	5.84	6.20
h	.010	.016	0.25	0.41
L	.016	.035	0.41	0.89
N	SEE VARIATIONS			
X	SEE VARIATIONS			
Y	.071	.087	1.803	2.209
α	0°	8°	0°	8°

VARIATIONS:

DIM	INCHES		MILLIMETERS		N
	MIN.	MAX.	MIN.	MAX.	
D	.189	.196	4.80	4.98	16 AA
S	.0020	.0070	0.05	0.18	
X	.107	.123	2.72	3.12	
D	.337	.344	8.56	8.74	20 AB
S	.0500	.0550	1.270	1.397	
D	.337	.344	8.56	8.74	24 AC
S	.0250	.0300	0.635	0.762	
D	.386	.393	9.80	9.98	28 AD
S	.0250	.0300	0.635	0.762	
X	.271	.287	6.88	7.29	

NOTES:

1. D & E DO NOT INCLUDE MOLD FLASH OR PROTRUSIONS
2. MOLD FLASH OR PROTRUSIONS NOT TO EXCEED .006" PER SIDE.
3. HEAT SLUG DIMENSIONS X AND Y APPLY ONLY TO 16 AND 28 LEAD POWER-QSOP PACKAGES.
4. CONTROLLING DIMENSIONS: INCHES.

MAXIM
 PROPRIETARY INFORMATION
 TITLE:
 PACKAGE OUTLINE, QSOP, .150", .025" LEAD PITCH
 APPROVAL: _____ DOCUMENT CONTROL NO: 21-0055 REV: B 1/1

+5V/+3V, 13-Bit, Serial, Force/Sense DACs with 10ppm/°C Internal Reference

NOTES

Maxim cannot assume responsibility for use of any circuitry other than circuitry entirely embodied in a Maxim product. No circuit patent licenses are implied. Maxim reserves the right to change the circuitry and specifications without notice at any time.

20 _____ **Maxim Integrated Products, 120 San Gabriel Drive, Sunnyvale, CA 94086 408-737-7600**