



Chipsmall Limited consists of a professional team with an average of over 10 year of expertise in the distribution of electronic components. Based in Hongkong, we have already established firm and mutual-benefit business relationships with customers from,Europe,America and south Asia,supplying obsolete and hard-to-find components to meet their specific needs.

With the principle of "Quality Parts,Customers Priority,Honest Operation,and Considerate Service",our business mainly focus on the distribution of electronic components. Line cards we deal with include Microchip,ALPS,ROHM,Xilinx,Pulse,ON,Everlight and Freescale. Main products comprise IC,Modules,Potentiometer,IC Socket,Relay,Connector.Our parts cover such applications as commercial,industrial, and automotives areas.

We are looking forward to setting up business relationship with you and hope to provide you with the best service and solution. Let us make a better world for our industry!



Contact us

Tel: +86-755-8981 8866 Fax: +86-755-8427 6832

Email & Skype: info@chipsmall.com Web: www.chipsmall.com

Address: A1208, Overseas Decoration Building, #122 Zhenhua RD., Futian, Shenzhen, China





+3.3V-Powered, EIA/TIA-562 Dual Transceiver with Receivers Active in Shutdown

MAX563

General Description

The MAX563 is a +3.3V-powered EIA/TIA-562 transceiver with two transmitters and two receivers. Because it implements the EIA/TIA-562 standard, the MAX563 communicates with RS-232 transceivers, yet consumes far less power; this makes it ideal for battery-powered, hand-held computers. And, the MAX563 guarantees a 116kbps data rate while maintaining $\pm 3.7V$ EIA/TIA-562 signal levels, which makes it compatible with LapLink™ software.

An on-board charge pump converts the +3.3V supply to the $\pm 6.6V$ needed to produce the EIA/TIA-562 output voltage levels. Four 0.1 μF charge-pump capacitors and a bypass capacitor of similar size are the only external components required.

When the MAX563's charge pumps and transmitters are shut down to save power, the receivers remain active to continuously monitor signals from external devices (for example, ring indicator from modems). The two receivers' outputs can be enabled and disabled independently of the shutdown function to allow two ports—generally of different types—to be wire-OR connected at the UART.

Applications

- Handterminals
- Battery-Powered Equipment
- Bar-Code Readers
- Notebook and Palmtop Computers

Typical Operating Circuit

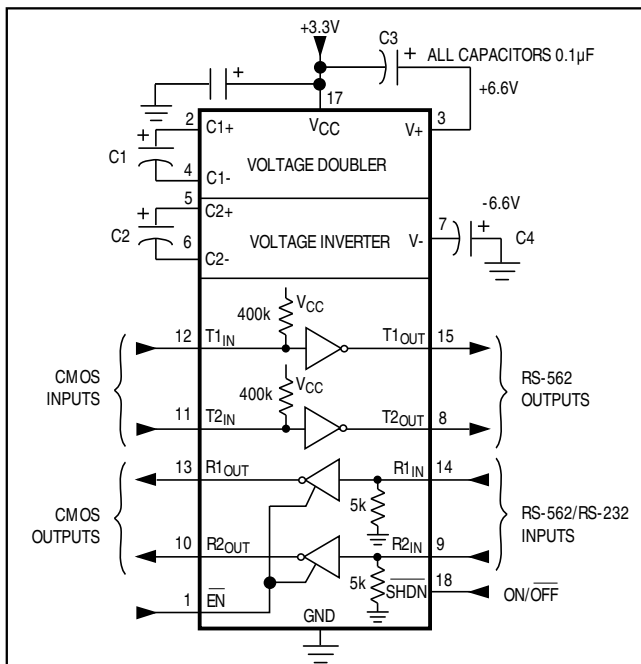

™ LapLink is a registered trademark of Traveling Software, Inc.

Features

- ◆ Guaranteed Interoperability with RS-232
- ◆ Operates from a Single +3.0V to +3.6V Supply
- ◆ 2 Drivers, 2 Receivers
- ◆ Receivers Active in Shutdown Mode
- ◆ Low-Power Shutdown: 10 μA Max
- ◆ Small Package—18-Pin Wide SO
- ◆ Three-State TTL/CMOS Receiver Outputs
- ◆ 116kbps Guaranteed Data Rate

Ordering Information

| PART | TEMP. RANGE | PIN-PACKAGE |
|-----------|--------------|----------------|
| MAX563CPN | 0°C to +70°C | 18 Plastic DIP |
| MAX563CWN | 0°C to +70°C | 18 Wide SO |
| MAX563C/D | 0°C to +70°C | Dice * |

* Dice are specified at $T_A = +25^\circ C$.

Pin Configuration

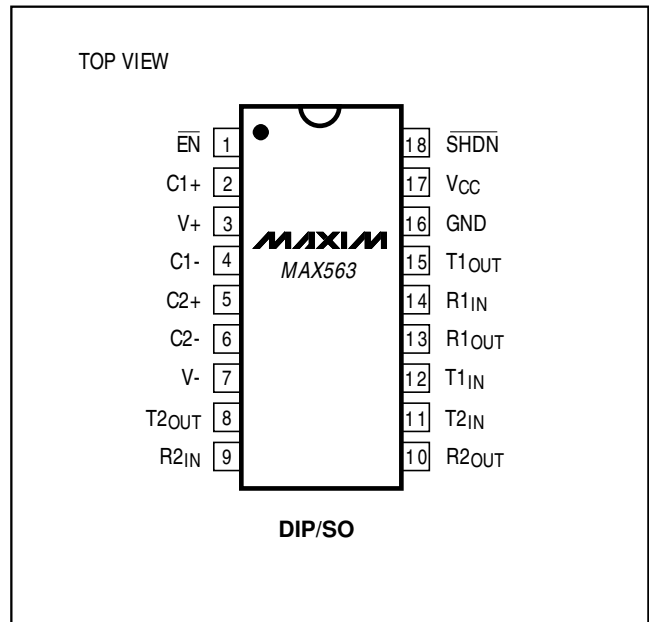

Call toll free 1-800-998-8800 for free samples or literature.

+3.3V-Powered, EIA/TIA-562 Dual Transceiver with Receivers Active in Shutdown

ABSOLUTE MAXIMUM RATINGS

| | | | |
|---|------------------------------|--|---|
| Power Supply Ranges | | Continuous Power Dissipation ($T_A = +70^\circ\text{C}$) | |
| Supply Voltage (V_{CC}) | -0.3V to +6V | Plastic DIP | 889mW |
| Input Voltages | | Wide SO | 762mW |
| T_{IN} | -0.3V to ($V_{CC} - 0.3V$) | Operating Temperature Range | 0°C to $+70^\circ\text{C}$ |
| R_{IN} | $\pm 25V$ | Storage Temperature Range | -65°C to $+160^\circ\text{C}$ |
| T_{OUT} (Note 1) | $\pm 15V$ | Lead Temperature (soldering, 10sec) | $+300^\circ\text{C}$ |
| Output Voltages | | | |
| T_{OUT} | $\pm 15V$ | | |
| R_{OUT} | -0.3V to ($V_{CC} + 0.3V$) | | |
| Driver/Receiver Output Short Circuit to GND | Continuous | | |

Note 1: Input voltage measured with T_{OUT} in high-impedance state. \overline{SHDN} or $V_{CC} = 0V$.

Stresses beyond those listed under "Absolute Maximum Ratings" may cause permanent damage to the device. These are stress ratings only, and functional operation of the device at these or any other conditions beyond those indicated in the operational sections of the specifications is not implied. Exposure to absolute maximum rating conditions for extended periods may affect device reliability.

ELECTRICAL CHARACTERISTICS

($V_{CC} = 3.0V$ to $3.6V$, C_1 - $C_4 = 0.1\mu\text{F}$, $T_A = T_{MIN}$ to T_{MAX} , unless otherwise noted.)

| PARAMETER | SYMBOL | CONDITIONS | MIN | TYP | MAX | UNITS |
|--------------------------------------|----------|--|--------------|--------------|----------|---------------|
| RS-562 TRANSMITTERS | | | | | | |
| Output Voltage Swing | | All transmitter outputs loaded with $3k\Omega$ to GND | ± 3.7 | ± 4.5 | | V |
| Data Rate | | $R_L = 3k\Omega$, $C_L = 1000\text{pF}$, $T_A = +25^\circ\text{C}$ | | 200 | 116 | kbps |
| Input Logic Threshold Low | V_{IL} | | | | 0.6 | V |
| Input Logic Threshold High | V_{IH} | | 2.4 | | | V |
| Logic Pull-Up/Input Current | | $\overline{SHDN} = V_{CC}$ | | 2 | 20 | μA |
| | | $\overline{SHDN} = 0V$ | | ± 0.01 | ± 1 | |
| Output Leakage Current | | $V_{CC} = 3.6V$, $\overline{SHDN} = 0V$, $V_{OUT} = \pm 15V$ | | ± 0.01 | ± 10 | μA |
| | | $V_{CC} = \overline{SHDN} = 0V$, $V_{OUT} = \pm 15V$ | | ± 0.01 | ± 10 | |
| Transmitter Output Resistance | | $V_{CC} = V_+ = V_- = 0V$, $V_{OUT} = \pm 2V$ | 300 | 10M | | Ω |
| Output Short-Circuit Current | | $V_{OUT} = 0V$ | | ± 15 | ± 60 | mA |
| RS-232/RS-562 RECEIVERS | | | | | | |
| Input Voltage Operating Range | | | | | ± 25 | V |
| Input Threshold Low | V_{IL} | $V_{CC} = 3.3V$ | | | 0.4 | V |
| Input Threshold High | V_{IH} | $V_{CC} = 3.3V$ | 2.4 | | | V |
| Input Hysteresis | | $\overline{SHDN} = V_{CC} = 3.3V$ (no hysteresis when $\overline{SHDN} = 0V$) | 0.1 | 0.5 | 1.0 | V |
| Input Resistance | R_{IN} | | 3 | 5 | 7 | $k\Omega$ |
| Output Voltage Low | V_{OL} | $I_{OUT} = 3.2\text{mA}$ | | 0.2 | 0.4 | V |
| Output Voltage High | V_{OH} | $I_{OUT} = -0.5\text{mA}$ | $V_{CC}-0.6$ | $V_{CC}-0.2$ | | V |
| Output Leakage Current | | $\overline{EN} = V_{CC}$, $0V \leq V_{OUT} \leq V_{CC}$ | | ± 0.05 | ± 10 | μA |
| \overline{EN} Input Threshold Low | V_{IL} | | | | 0.6 | V |
| \overline{EN} Input Threshold High | V_{IH} | | 2.4 | | | V |

+3.3V-Powered, EIA/TIA-562 Dual Transceiver with Receivers Active in Shutdown

MAX563

ELECTRICAL CHARACTERISTICS (continued)

(V_{CC} = 3.0V to 3.6V, C₁-C₄ = 0.1μF, T_A = T_{MIN} to T_{MAX}, unless otherwise noted.)

| PARAMETER | SYMBOL | CONDITIONS | MIN | TYP | MAX | UNITS |
|--|---------------------------------------|---|---|-----|------|-------|
| POWER SUPPLY | | | | | | |
| Operating Supply Voltage | V _{CC} | | 3.0 | | 3.6 | V |
| V _{CC} Supply Current | I _{CC} | No load | | 3 | 8 | mA |
| | | R _L = 3kΩ on both outputs, inputs static | | 8 | | |
| Shutdown Supply Current | I _{CC} | Figure 1 | T _A = +25°C | 0.1 | 10 | μA |
| | | | T _A = T _{MIN} to T _{MAX} | 2 | 50 | |
| SHDN Input Leakage Current | | | | 0.1 | ±1 | μA |
| SHDN Threshold Low | V _{IL} | | | | 0.6 | V |
| SHDN Threshold High | V _{IH} | | 2.4 | | | V |
| AC CHARACTERISTICS | | | | | | |
| Transition Slew Rate | | C _L = 50pF to 2500pF, R _L = 3kΩ to 7kΩ, V _{CC} = 3.3V, T _A = +25°C, measured from +3V to -3V or -3V to +3V (Note 2) | 4 | 6 | 30 | V/μs |
| Transmitter Propagation Delay | t _{PHLT} | Figure 2 | | 1.3 | 3.5 | μs |
| | t _{PLHT} | | | 1.5 | 3.5 | |
| Receiver Propagation Delay (Normal Operation) | t _{PHLR} | Figure 3 | | 0.5 | 1.0 | μs |
| | t _{PLHR} | | | 0.6 | 1.0 | |
| Receiver Propagation Delay (Shutdown) | t _{PHLS} | Figure 3 | | 0.5 | 10.0 | μs |
| | t _{PLHS} | | | 2.5 | 10.0 | |
| Receiver-Output Enable Time | t _{ER} | Figure 4 | | 125 | 500 | ns |
| Receiver-Output Disable Time | t _{DR} | Figure 4 | | 160 | 500 | ns |
| Transmitter-Output Enable Time | t _{ET} | Includes charge pump start-up | | 300 | | μs |
| Transmitter-Output Disable Time | t _{DT} | Figure 5 | | 600 | | ns |
| Transmitter Propagation Delay Skew | t _{PHLT} – t _{PLHT} | | | 300 | | ns |
| Receiver Propagation Delay Skew (Normal Operation) | t _{PHLR} – t _{PLHR} | | | 100 | | ns |

Note 2: Minimum slew rate is specified with C_L = 1000pF for data rates above 20kbps, corresponding with EIA/TIA-562.

+3.3V-Powered, EIA/TIA-562 Dual Transceiver with Receivers Active in Shutdown

Pin Description

| PIN | NAME | FUNCTION |
|--------|---------------------------------------|--|
| 1 | $\overline{\text{EN}}$ | Receiver enable. Connect $\overline{\text{EN}}$ to GND to enable receivers, and take $\overline{\text{EN}}$ high to disable receivers. |
| 2 | C1+ | Positive terminal of positive charge-pump capacitor. |
| 3 | V+ | +2V _{CC} voltage generated by the positive charge pump. The voltage on V+ collapses to V _{CC} when SHDN is low. |
| 4 | C1- | Negative terminal of positive charge-pump capacitor. |
| 5 | C2+ | Positive terminal of inverting charge-pump capacitor. |
| 6 | C2- | Negative terminal of inverting charge-pump capacitor. |
| 7 | V- | -2V _{CC} voltage generated by the inverting charge pump. The voltage on V- collapses to GND when SHDN is low. |
| 8, 15 | T2 _{OUT} , T1 _{OUT} | EIA/TIA-562 voltage-level transmitter outputs. These outputs are disabled (Hi-Z) when SHDN is low. |
| 9, 14 | R2 _{IN} , R1 _{IN} | EIA/TIA-562 and EIA/TIA-232 voltage-level receiver inputs. |
| 10, 13 | R2 _{OUT} , R1 _{OUT} | CMOS receiver outputs. These outputs are active regardless of the state of SHDN. They are enabled when $\overline{\text{EN}}$ is low, and disabled (Hi-Z) when $\overline{\text{EN}}$ is high. |
| 11, 12 | T2 _{IN} , T1 _{IN} | CMOS driver inputs. |
| 16 | GND | Ground. |
| 17 | V _{CC} | +3.0V to +3.6V supply voltage. |
| 18 | $\overline{\text{SHDN}}$ | Shutdown control. Connect to GND to shut down the charge pumps and the transmitters. Take high to turn on the charge pumps and to enable the transmitters. |

Detailed Description

The MAX563 consists of three sections: charge-pump voltage converters, transmitters (drivers), and receivers. Both the transmitters and the receivers are inverting.

+3V to ±6V, Dual Charge-Pump Voltage Converter

Two charge pumps either invert or double the incoming V_{CC} to generate the voltages required by the transmitters. The first charge pump uses capacitor C1 to double V_{CC}; the resulting voltage is stored on the V+ reservoir capacitor. The second charge pump uses capacitor C2 to invert V+; this negative voltage is stored on the V- capacitor.

When $\overline{\text{SHDN}}$ is low, the charge pumps are turned off, V+ is pulled down to V_{CC} by a 1k Ω resistor, and V- rises to GND.

It is possible to draw some power from the V+ and V- pins for external use. However, doing so diminishes the charge-pump output voltages and reduces noise margins, so it is not recommended.

EIA/TIA-562 Transmitters

The MAX563's drivers are inverting level translators that convert +3V logic inputs to EIA/TIA-562 voltage levels. With a V_{CC} supply of only 3.0V, the driver outputs deliver the EIA/TIA-562 $\pm 3.7\text{V}$ minimum specification under worst-case conditions—when both transmitters are loaded with 3k Ω receivers (either EIA/TIA-232 or EIA/TIA-562).

The transmitters are fast: the guaranteed data rate with standard loads is 116kbps, which is the highest rate commonly used by PC-to-PC communication software, such as LapLink. The highest practical data rate may be reduced if the other communicating device (RS-562 or RS-232) is not as fast, or if the cables present an excessive capacitive load (>1000pF). Each transmitter is designed to drive a single receiver; transmitters can be paralleled to drive multiple receivers.

When $\overline{\text{SHDN}}$ is low, the driver outputs are turned off. Their output leakage currents are less than 10 μA when pulled to GND or when driven to $\pm 15\text{V}$. This enables two transmitters to be connected to the same line, provided that one of them is always disabled by taking $\overline{\text{SHDN}}$ low.

+3.3V-Powered, EIA/TIA-562 Dual Transceiver with Receivers Active in Shutdown

MAX563

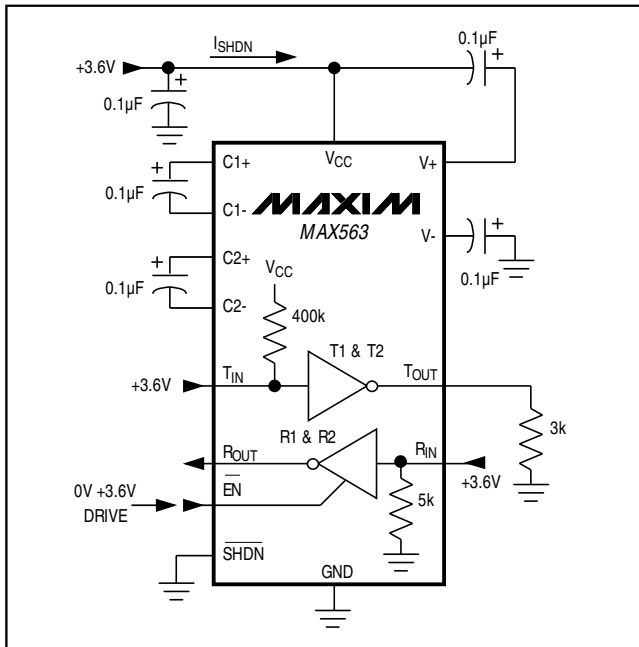

Figure 1. Shutdown Current Test Circuit

The inputs of unused drivers may be left unconnected because they have internal 400kΩ pull-ups to VCC. Unused inputs may also be connected to GND or VCC, but VCC provides lower power consumption because of the internal pull-ups.

EIA/TIA-562 and EIA/TIA-232 Receivers

The MAX563's receivers convert ±3.7V to ±13.2V EIA/TIA-562 signal levels into +3V logic levels; they are rated to receive signals up to ±25V to accommodate EIA/TIA-232 signals as well. Both receivers invert. Their inputs are each equipped with an internal 5kΩ (nominal) terminating resistor connected to ground, and the input logic thresholds are 0.4V and 2.4V. The positive logic-low threshold (V_{IL}) ensures the receiver outputs remain high whenever their inputs are left open.

The receivers are active when EN is low, and have high-impedance outputs when EN is high.

When SHDN is high, the receivers have hysteresis. This produces clean output transitions, even with slow-moving input signals that exhibit moderate amounts of noise and ringing. When shut down, the receivers have no hysteresis, and the propagation delay increases.

Shutdown and Enable Control

The SHDN and EN controls are independent. Both receivers are always active when EN is low. With EN low and SHDN high, the receivers operate at full speed

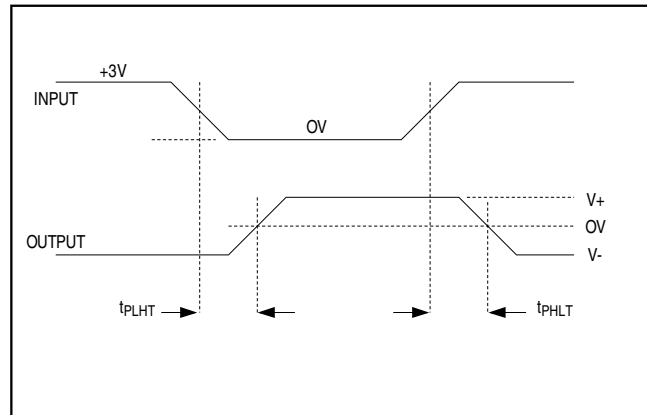

Figure 2. Transmitter Propagation Delay Timing

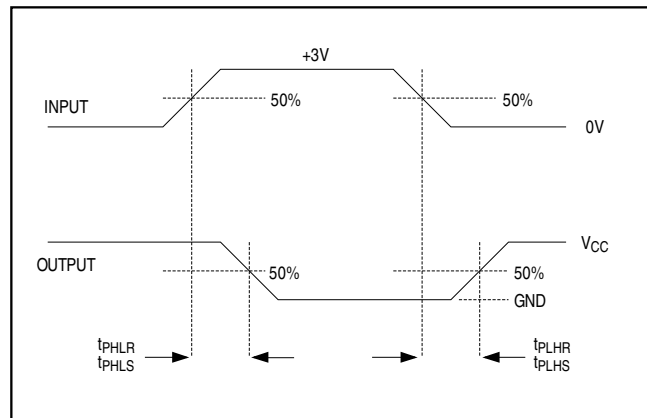

Figure 3. Receiver Propagation Delay Timing

and have hysteresis. When active in shutdown mode (EN = SHDN = low), the receivers operate at reduced power and speed, and without hysteresis.

The charge pumps and transmitters operate only when SHDN is high; they are unaffected by EN. When shut down (SHDN = low) or unpowered (VCC = 0V), the transmitter outputs are high impedance if they are backdriven with voltages not exceeding ±15V. The pull-up resistors at the driver inputs are disconnected in shutdown mode to save power. During shutdown, V+ is pulled down to VCC, and V- rises to GND.

+3.3V-Powered, EIA/TIA-562 Dual Transceiver with Receivers Active in Shutdown

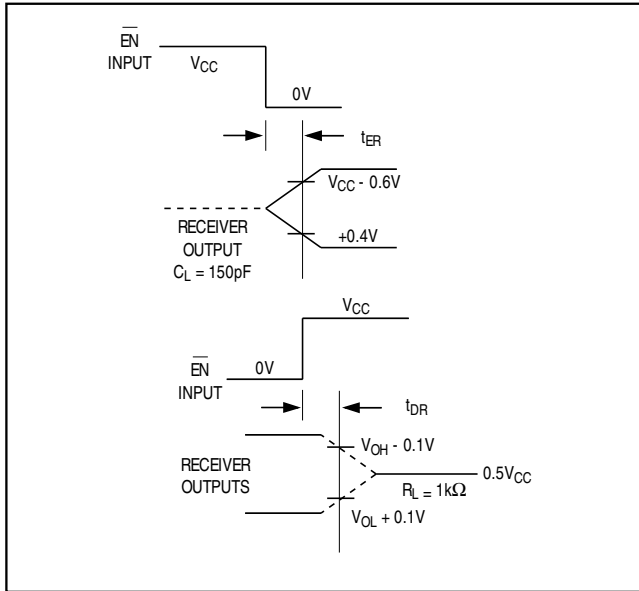

Figure 4. Receiver Output Enable and Disable Timing

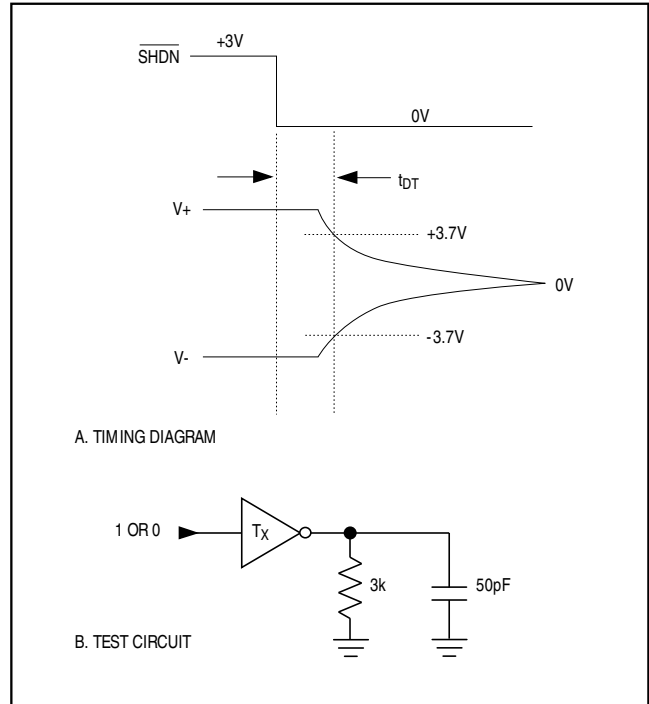

Figure 5. Transmitter Output Disable Timing

Applications Information

Charge-Pump Capacitor Selection

Normally, 0.1 μ F capacitors can be used for all locations. To reduce output ripple, increase the values of the V+ and V- capacitors. If your capacitors have a very wide tolerance, consider using a nominal value a little larger than 0.1 μ F to ensure that the actual capacitance does not fall below about 80nF. For circuits designed to operate over a wide range of temperatures, consider using slightly larger capacitors to compensate for any loss of capacitance at temperature extremes. No advantage is gained by using values larger than 10 μ F.

Power-Supply Decoupling

Use a capacitor with the same value as the charge-pump capacitors.

+3.3V-Powered, EIA/TIA-562 Dual Transceiver with Receivers Active in Shutdown

MAX563

Table 1. Summary of EIA/TIA-232E/V.28 and EIA/TIA-562 Specifications

| PARAMETER | CONDITION | EIA/TIA-232E/V.28 SPECIFICATION | EIA/TIA-562 SPECIFICATION |
|---|-----------------------------|---------------------------------|---------------------------|
| Driver Output Voltage 0 Level | 3kΩ to 7kΩ load | 5.0V to 15.0V | 3.7V to 13.2V |
| 1 Level | | -5.0V to -15.0V | -3.7V to -13.2V |
| Maximum Output Level | No load | ±25V | ±13.2V |
| Signal Rate (3kΩ ≤ R _L ≤ 7kΩ) | C _L = 2500pF | Up to 20kbps | Up to 20kbps |
| | C _L = 1000pF | Not defined | Up to 64kbps |
| Receiver Input Thresholds 0 Level | | 3.0V to 15.0V | 3.0V to 15.0V |
| 1 Level | | -3.0V to -15.0V | -3.0V to -15.0V |
| Maximum Input Level | | ±25V | ±25V |
| Maximum Instantaneous Slew Rate | | 30V/μs | 30V/μs |
| Maximum Driver Output Short-Circuit Current | | 100mA | 60mA |
| Transition Rate on Driver Output | | V.28 1ms or 3% of the period | 4V/μs |
| | | RS-232 4% of the period | |
| Driver Output Resistance with Power Off | -2V < V _{OUT} < 2V | 300Ω | 300Ω |

Table 2. DB9/DB25 Cable Connections Commonly Used for EIA/TIA-232E, EIA/TIA-562 and V.24 Asynchronous Interfaces

| DB9 PIN | DB25 PIN | NAME | SYMBOL | FUNCTION |
|---------|----------|--|--------|-----------------------------|
| 1 | 8 | Received Line Signal Detector (sometimes called Data Carrier Detect) | DCD | Handshake from DCE |
| 2 | 3 | Receiver Data | RxD | Data from DCE |
| 3 | 2 | Transmit Data | TxD | Data from DTE |
| 4 | 20 | Data Terminal Ready | DTR | Handshake from DTE |
| 5 | 7 | Signal Ground | GND | Reference point for signals |
| 6 | 6 | Data Set Ready | DSR | Handshake from DCE |
| 7 | 4 | Request to Send | RTS | Handshake from DTE |
| 8 | 5 | Clear to Send | CTS | Handshake from DCE |
| 9 | 22 | Ring Indicator | RI | Handshake from DCE |

+3.3V-Powered, EIA/TIA-562 Dual Transceiver with Receivers Active in Shutdown

Chip Topography

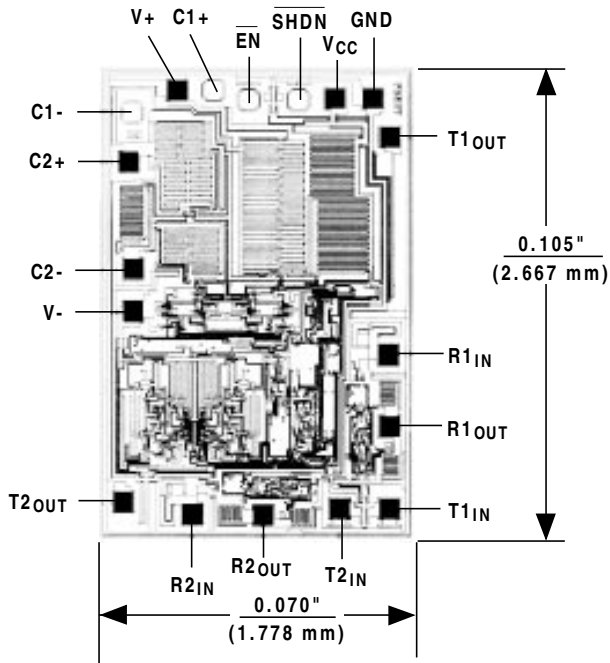

TRANSISTOR COUNT: 189;
 SUBSTRATE CONNECTED TO V+.

Maxim cannot assume responsibility for use of any circuitry other than circuitry entirely embodied in a Maxim product. No circuit patent licenses are implied. Maxim reserves the right to change the circuitry and specifications without notice at any time.

8 Maxim Integrated Products, 120 San Gabriel Drive, Sunnyvale, CA 94086 (408) 737-7600