



Chipsmall Limited consists of a professional team with an average of over 10 year of expertise in the distribution of electronic components. Based in Hongkong, we have already established firm and mutual-benefit business relationships with customers from,Europe,America and south Asia,supplying obsolete and hard-to-find components to meet their specific needs.

With the principle of "Quality Parts,Customers Priority,Honest Operation,and Considerate Service",our business mainly focus on the distribution of electronic components. Line cards we deal with include Microchip,ALPS,ROHM,Xilinx,Pulse,ON,Everlight and Freescale. Main products comprise IC,Modules,Potentiometer,IC Socket,Relay,Connector.Our parts cover such applications as commercial,industrial, and automotives areas.

We are looking forward to setting up business relationship with you and hope to provide you with the best service and solution. Let us make a better world for our industry!



## Contact us

Tel: +86-755-8981 8866 Fax: +86-755-8427 6832

Email & Skype: info@chipsmall.com Web: www.chipsmall.com

Address: A1208, Overseas Decoration Building, #122 Zhenhua RD., Futian, Shenzhen, China





# MAX5889/MAX5890/MAX5891 Evaluation Kits

## General Description

The MAX5889, MAX5890, and MAX5891 evaluation kits (EV kits) are each fully assembled and tested printed-circuit boards (PCBs) that contain all the components necessary to evaluate the performance of the MAX5889, MAX5890, and MAX5891 600Msps digital-to-analog converters (DACs). All three DACs feature LVDS inputs, integrated 1.2V bandgap voltage references, and differential current outputs. The three EV kits use the same PCB and components except for the DACs. The MAX5889, MAX5890, and MAX5891 are 12-bit, 14-bit, and 16-bit DACs, respectively. The EV kits operate with LVDS-compatible digital data inputs, a single-ended clock input, and a 3.3V/1.8V dual power supply for simple board operation. The EV kits feature differential current to single-ended voltage output conversion circuitry and offer an external 1.25V voltage reference that can be used to overdrive the integrated voltage reference.

## Component List

DESIGNATION	QTY	DESCRIPTION
C1-14, C33, C37, C38	17	0.1 $\mu$ F $\pm$ 10%, 10V X5R ceramic capacitors (0402) TDK C1005X5R1A104KT or Taiyo Yuden LMK105BJ104KV
C15-C19	5	1 $\mu$ F $\pm$ 10%, 10V X5R ceramic capacitors (0603) TDK C1608X5R1A105KT
C20-C24	5	10 $\mu$ F $\pm$ 10%, 10V tantalum capacitors (A) AVX TAJA106K010R or KEMET T494A106K010AS
C25-C29	5	47 $\mu$ F $\pm$ 10%, 6.3V tantalum capacitors (B) AVX TAJB476K006R or KEMET T494B476K006AS
C30, C31, C32, C34, C35, C36	0	Not installed, ceramic capacitors (0603)
CLK, OUTPUT	2	SMA PC mount vertical connectors
J1, J2	2	2 x 20-pin surface-mount headers (0.1in)
JU1-JU4	4	2-pin headers
L1-L5	5	Ferrite bead cores (0805) Fair-Rite 2508051217Z0

## Features

- ◆ Enables Fast Evaluation and Performance Testing
- ◆ On-Board External 1.25V Voltage Reference Circuit
- ◆ SMA Coaxial Connectors for Clock Input and Analog Output
- ◆ LVDS-Compatible Inputs
- ◆ Full-Scale Current Output Configured for 20mA
- ◆ 50 $\Omega$  Matched Clock Input and Analog Output Signal Lines
- ◆ Single-Ended-to-Differential Clock Signal Conversion Circuitry
- ◆ Differential Current to Single-Ended Voltage Output Conversion Circuitry
- ◆ Fully Assembled and Tested

## Ordering Information

PART	TEMP RANGE	IC PACKAGE
MAX5889EVKIT#	0°C to +70°C*	68 QFN-EP
MAX5890EVKIT#	0°C to +70°C*	68 QFN-EP
MAX5891EVKIT#	0°C to +70°C*	68 QFN-EP

#Denotes an RoHS-compliant EV kit.

\*This limited temperature range applies to the EV kit PCB only. The MAX5889/MAX5890/MAX5891 IC temperature range is -40°C to 85°C.

EP = Exposed paddle.

## Part Selection Table

PART	RESOLUTION (BITS)
MAX5889EGK+	12
MAX5890EGK+	14
MAX5891EGK+	16

Evaluate: MAX5889/MAX5890/MAX5891

# MAX5889/MAX5890/MAX5891 Evaluation Kits

## Component List (continued)

DESIGNATION	QTY	DESCRIPTION
OUTIP, OUTIN	0	Not installed, SMA PC mount vertical connectors
R1, R2	2	49.9Ω ±0.1% resistors (0603) IRC PFC-W0603RLF-03-49R9-B
R3	1	100Ω ±1% resistor (0603)
R4	1	2kΩ ±1% resistor (0603)
R5, R6	2	24.9Ω ±1% resistors (0603)
R7, R8	0	Not installed, resistors (0603)
T1, T2	2	Transformers Mini-Circuits ADTL1-12+
T3	1	1:1 transformer Coilcraft TTWB-1-B
U1	1	See the <i>EV Kit Specific Component List</i>
U2	1	1.25V voltage reference (SO-8) MAX6161BESA+ or MAX6161AESA+
—	4	Shunts (JU1–JU4)
—	1	PCB: MAX5891/90/89 Evaluation Kit#

## EV Kit Specific Component List

EV KIT PART NUMBER	DESIGNATION	DESCRIPTION
MAX5889EVKIT#	U1	MAX5889EGK (68-pin, 10mm x 10mm, QFN with EP)
MAX5890EVKIT#	U1	MAX5890EGK (68-pin, 10mm x 10mm, QFN with EP)
MAX5891EVKIT#	U1	MAX5891EGK (68-pin, 10mm x 10mm, QFN with EP)

## Quick Start

### Recommended Equipment

- Three 3.3V, 100mA power supplies
- Two 1.8V, 100mA power supplies
- One signal generator with low phase noise and low jitter for clock input (e.g., HP 8664A)
- One signal generator for pattern generator synchronization (e.g., HP 8664A)
- One LVDS digital pattern generator for data inputs (e.g., HP 81250)
- Spectrum analyzer (e.g., HP 8560E)
- Voltmeter

The EV kit is a fully assembled and tested surface-mount board. Follow the steps below for board operation. **Caution: Do not turn on power supplies or enable signal generators until all connections are completed (Figure 1).**

- 1) Verify that shunts are not installed across jumper JU1 (normal operation).
- 2) Verify that shunts are installed across jumpers JU2 and JU3 (external reference).
- 3) Synchronize the digital pattern generator with the clock signal generator (Figure 1).
- 4) Connect the clock signal generator to the EV kit CLK SMA connector.
- 5) Verify that the digital pattern generator HP 81250 is programmed for valid LVDS voltage levels.
- 6) Connect the digital pattern generator output to the input header connectors J1 and J2 on the EV kit board. See Table 1 for MAX5889, MAX5890, and MAX5891 EV kit header pin configurations.

## Component Suppliers

SUPPLIER	PHONE	FAX	WEBSITE
AVX Corp.	843-946-0238	843-626-3123	www.avxcorp.com
Coilcraft, Inc.	847-639-6400	847-639-1469	www.coilcraft.com
Fair-Rite Products Corp.	845-895-2055	845-895-2629	www.fair-rite.com
IRC, Inc.	361-992-7900	361-992-3377	www.irctt.com
KEMET Corp.	864-963-6300	864-963-6322	www.kemet.com
Mini-Circuits	718-934-4500	718-934-7092	www.minicircuits.com
Taiyo Yuden	800-348-2496	847-925-0899	www.t-yuden.com
TDK Corp.	847-803-6100	847-390-4405	www.component.tdk.com

**Note:** Indicate that you are using the MAX5889, MAX5890, or MAX5891 when contacting these component suppliers.

# MAX5889/MAX5890/MAX5891 Evaluation Kits

Evaluate: MAX5889/MAX5890/MAX5891

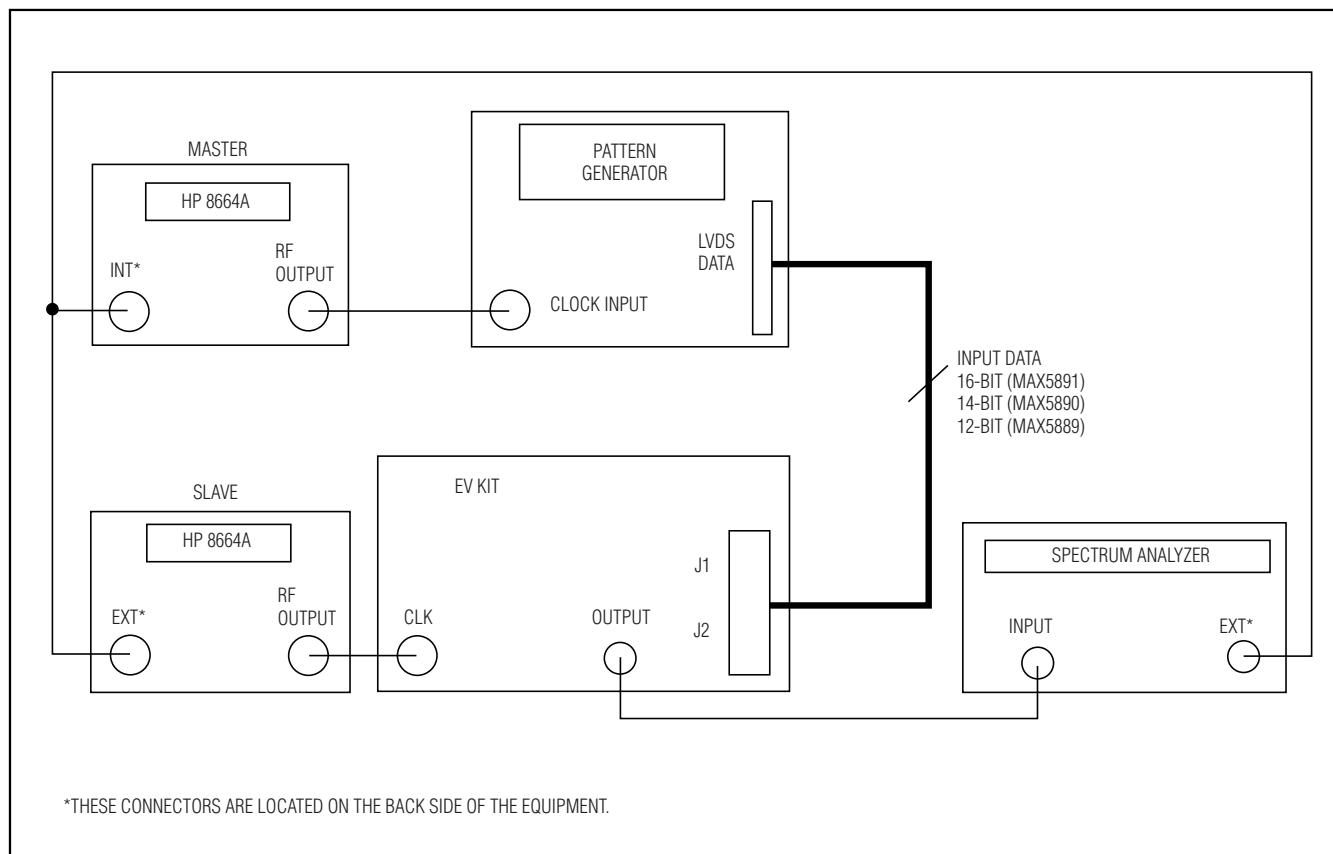

Figure 1. MAX5889/MAX5890/MAX5891 EV Kit Quick Start Setup

- 7) Connect a 1.8V power supply to the AVDD1 PCB pad. Connect the ground terminal of this supply to the AGND PCB pad.
- 8) Connect a 3.3V power supply to the AVDD2 PCB pad. Connect the ground terminal of this supply to the AGND PCB pad.
- 9) Connect a 1.8V power supply to the DVDD1 PCB pad. Connect the ground terminal of this supply to the DGND PCB pad.
- 10) Connect a 3.3V power supply to the DVDD2 PCB pad. Connect the ground terminal of this supply to the DGND PCB pad.
- 11) Connect a 3.3V power supply to the VDD\_CK PCB pad. Connect the ground terminal of this supply to the CGND PCB pad.
- 12) Turn on all five power supplies.
- 13) Set the clock signal generator output power between +8dBm to +12dBm and the frequency ( $f_{CLK}$ ) to  $\leq 600$ MHz.
- 14) Enable the clock signal generator and the digital pattern generator.
- 15) Use the spectrum analyzer to view the output spectrum or view the output waveform by connecting an oscilloscope to the OUTPUT SMA connector on the EV kit.

# MAX5889/MAX5890/MAX5891 Evaluation Kits

Evaluate: MAX5889/MAX5890/MAX5891

**Table 1. MAX5889/MAX5890/MAX5891 EV Kit Board Connector Guide (J1 and J2)**

EV KIT CONNECTOR PIN	MAX5891 INPUT	MAX5890 INPUT	MAX5889 INPUT
J1-31	D15P (MSB)	D13P (MSB)	D11P (MSB)
J1-29	D15N (MSB)	D13N (MSB)	D11N (MSB)
J1-27	D14P	D12P	D10P
J1-25	D14N	D12N	D10N
J1-23	D13P	D11P	D9P
J1-21	D13N	D11N	D9N
J1-19	D12P	D10P	D8P
J1-17	D12N	D10N	D8N
J1-15	D11P	D9P	D7P
J1-13	D11N	D9N	D7N
J1-11	D10P	D8P	D6P
J1-9	D10N	D8N	D6N
J1-7	D9P	D7P	D5P
J1-5	D9N	D7N	D5N
J1-3	D8P	D6P	D4P
J1-1	D8N	D6N	D4N
J2-39	D7P	D5P	D3P
J2-37	D7N	D5N	D3N
J2-35	D6P	D4P	D2P
J2-33	D6N	D4N	D2N
J2-31	D5P	D3P	D1P
J2-29	D5N	D3N	D1N
J2-27	D4P	D2P	D0P (LSB)
J2-25	D4N	D2N	D0N (LSB)
J2-23	D3P	D1P	N.C.
J2-21	D3N	D1N	N.C.
J2-19	D2P	D0P (LSB)	N.C.
J2-17	D2N	D0N (LSB)	N.C.
J2-15	D1P	N.C.	N.C.
J2-13	D1N	N.C.	N.C.
J2-11	D0P (LSB)	N.C.	N.C.
J2-9	D0N (LSB)	N.C.	N.C.

## Detailed Description

The MAX5889/MAX5890/MAX5891 EV kits are designed to simplify the evaluation of the MAX5889 (12-bit), MAX5890 (14-bit), and MAX5891 (16-bit) 600Msps, current-output DACs. The MAX5889/ MAX5890/MAX5891 converters operate with LVDS-compatible digital data inputs, a differential or single-ended clock input signal, and at least two power supplies (3.3V and 1.8V). The MAX5889/MAX5890/MAX5891 feature an internal 1.2V voltage reference.

The EV kits provide header connectors, J1 and J2, to interface with a pattern generator, circuitry that converts

the differential current outputs to single-ended voltage signal. Additionally, a circuit is provided to convert a user-supplied single-ended clock signal to a differential clock. The EV kit circuits also include an external 1.25V reference source U2 (MAX6161) and a test point connector, TP1, that can be used to overdrive the MAX5891 DAC's internal 1.2V bandgap reference. The EV kit PCB layout separates the circuit power into digital, analog, and clock planes to improve dynamic performance. The input data PCB traces are 100Ω differential controlled impedance and the analog output PCB traces are 50Ω controlled impedance.

# MAX5889/MAX5890/MAX5891 Evaluation Kits

Evaluate: MAX5889/MAX5890/MAX5891

## Power Supplies

The EV kits can operate from a single 1.8V power supply connected to the DVDD1 and AVDD1 input power pads, and a single 3.3V power supply connected to the DVDD2, AVDD2, and VDD\_CK input power pads for simple operation. However, five separate power supplies are recommended to optimize dynamic performance. The EV kit PCB layout is divided into three sections: digital, analog, and clock. Using separate power supplies for each section reduces noise and improves the integrity of the analog output signal. When using separate power supplies connect a 1.8V power supply across the DVDD1 and DGND pads and a 3.3V power supply across the DVDD2 and DGND pads (digital). Connect a 1.8V power supply across the AVDD1 and the AGND pads and a 3.3V power supply across the AVDD2 and the AGND pads (analog). Connect a 3.3V power supply across the VDD\_CK and the CGND pads (clock).

## LVDS Digital Input Data

The MAX5889/MAX5890/MAX5891 EV kits provide two 0.1in 2 x 20 headers (J1, J2) to interface an LVDS pattern generator to the EV kit. The header data pins labeled on the MAX5889/MAX5890/MAX5891 EV kit PCB are aligned with the MAX5891 DAC data input pins. See Table 1 to align the MAX5890 and MAX5889 input data bits from the pattern generator to the corresponding data pins on headers J1 and J2. The input data is latched on the rising edge of the clock signal.

## Clock Signal

The MAX5889/MAX5890/MAX5891 operate with a differential clock input signal. However, the EV kit boards only require an external single-ended clock signal connected to the CLK SMA connector. The EV kit features circuitry that converts a single-ended clock signal to a differential clock signal. The clock signal should be a low-jitter sine or square wave. A minimum signal power amplitude of +8dBm is recommended to drive the clock input. The DACs accept a clock input frequency range of 1MHz to 600MHz.

## Reference Voltage

The MAX5889/MAX5890/MAX5891 DACs require a reference voltage to set the full-scale output current of the DAC. The MAX5889/MAX5890/MAX5891 integrate a stable on-chip bandgap reference of 1.2V that is selected by default during initial power-up. An external voltage reference can be connected to test point TP1 to overdrive the internal voltage reference. The EV kit circuit

also features an on-board, external 1.25V reference (U2, MAX6161) that can be used to overdrive the internal voltage reference. U2 has a tighter voltage output tolerance and is less susceptible to temperature variations. See Table 2 to select the voltage reference source.

**Table 2. Reference Voltage Source (JU2 and JU3)**

SHUNT POSITION		REFIO PIN CONNECTION	EV KIT FUNCTION
JU2	JU3		
Not installed	Not installed	Open (REFIO becomes the output of the internal bandgap reference)	Internal 1.2V reference enabled or connect an external reference to TP1
Installed*	Installed	Connected to U2 (MAX6161)	U2 provides a precise 1.25V voltage reference

\*If jumper JU2 is installed, jumper JU3 must be installed.

## Full-Scale Output Current

The MAX5889/MAX5890/MAX5891 require an external resistor to set the full-scale output current. The EV kit full-scale current is set to 20mA with resistor R4. Replace resistor R4 to adjust the full-scale output current. Refer to the *Reference Architecture and Operation* section in the MAX5889/MAX5890/MAX5891 corresponding IC data sheets to select different values for resistor R4.

## Outputs

To achieve the best dynamic performance, the MAX5889/MAX5890/MAX5891 outputs are configured for differential current mode. The resistor and transformer network at the DAC output is designed to convert the differential current to a single-ended voltage signal with a 50Ω output impedance. When the OUTPUT connector is terminated with a 50Ω external load, the full-scale output signal level equals -2dBm.

To evaluate the converter's single-ended outputs, remove transformer T1. Probe the single-ended signals at the OUTIP and OUTIN SMA connectors (must be installed). In single-ended configuration the DAC output signal amplitude is equal to 1Vp-p at each of the outputs.

# MAX5889/MAX5890/MAX5891 Evaluation Kits

## Power-Down Mode

The DAC power-down/normal operation mode can be configured with jumper JU1. See Table 3 for jumper JU1 configuration.

**Table 3. Power-Down Mode (JU1)**

SHUNT POSITION	PD PIN CONNECTION	EV KIT FUNCTION
Installed	Connected to DVDD2	Power-down mode
Not installed	Internally pulled down	Normal operation

## PCB Layout

The MAX5889/MAX5890/MAX5891 EV kits are four-layer PCBs optimized for high-speed signals. All high-speed digital signal lines are routed through 100Ω differential impedance-matched transmission lines. All analog output traces are routed through 50Ω impedance-matched transmission lines. The lengths of these 100Ω and 50Ω transmission lines are matched to within 40 mils (1mm) to minimize layout-dependent data skew. The PCB layout separates the digital, analog, and clock sections of the circuit for optimum performance.

# MAX5889/MAX5890/MAX5891 Evaluation Kits

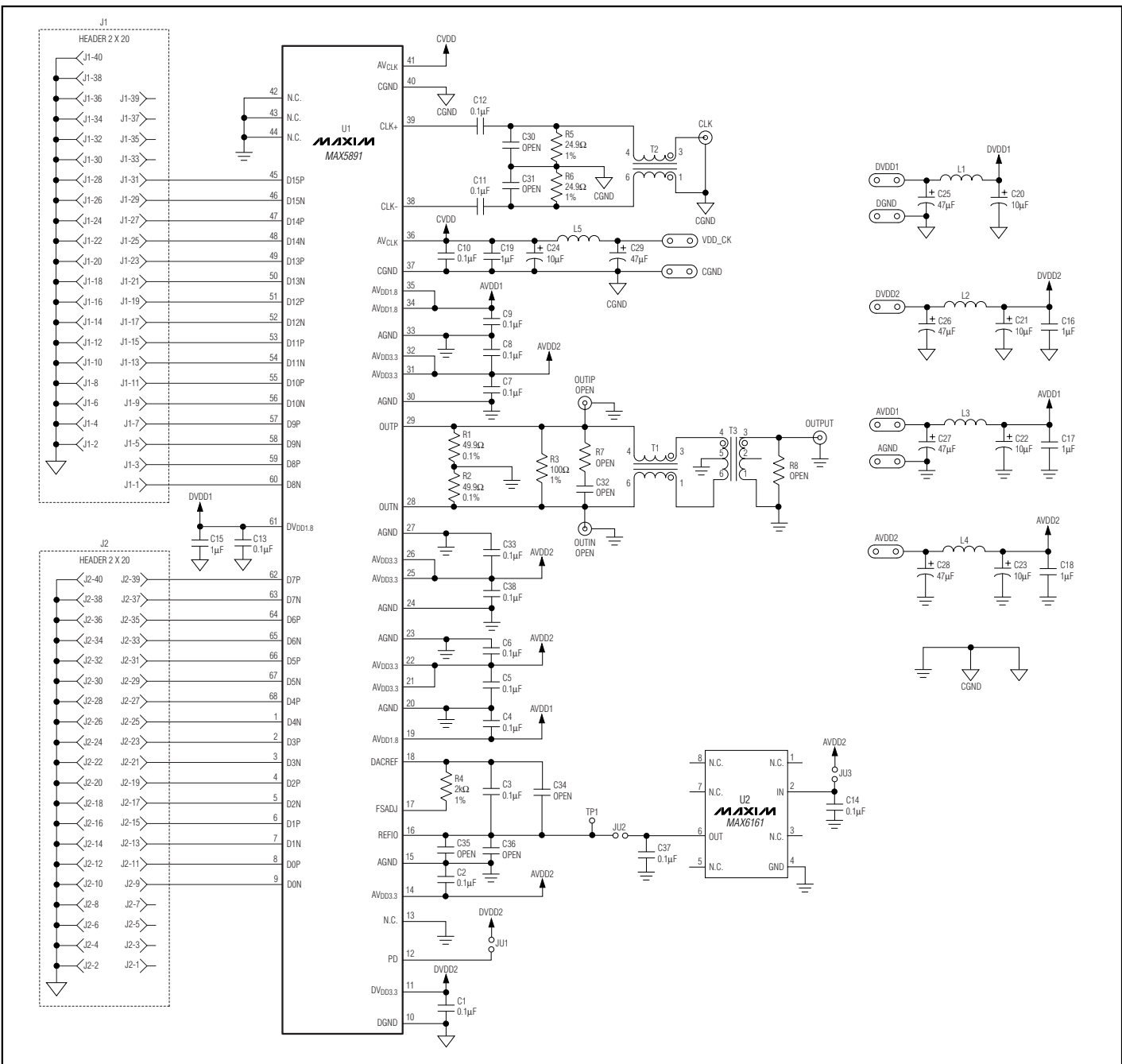

Figure 2. MAX5891 EV Kit Schematic

Evaluate: MAX5889/MAX5890/MAX5891



# Evaluate: MAX5889/MAX5890/MAX5891

## MAX5889/MAX5890/MAX5891 Evaluation Kits

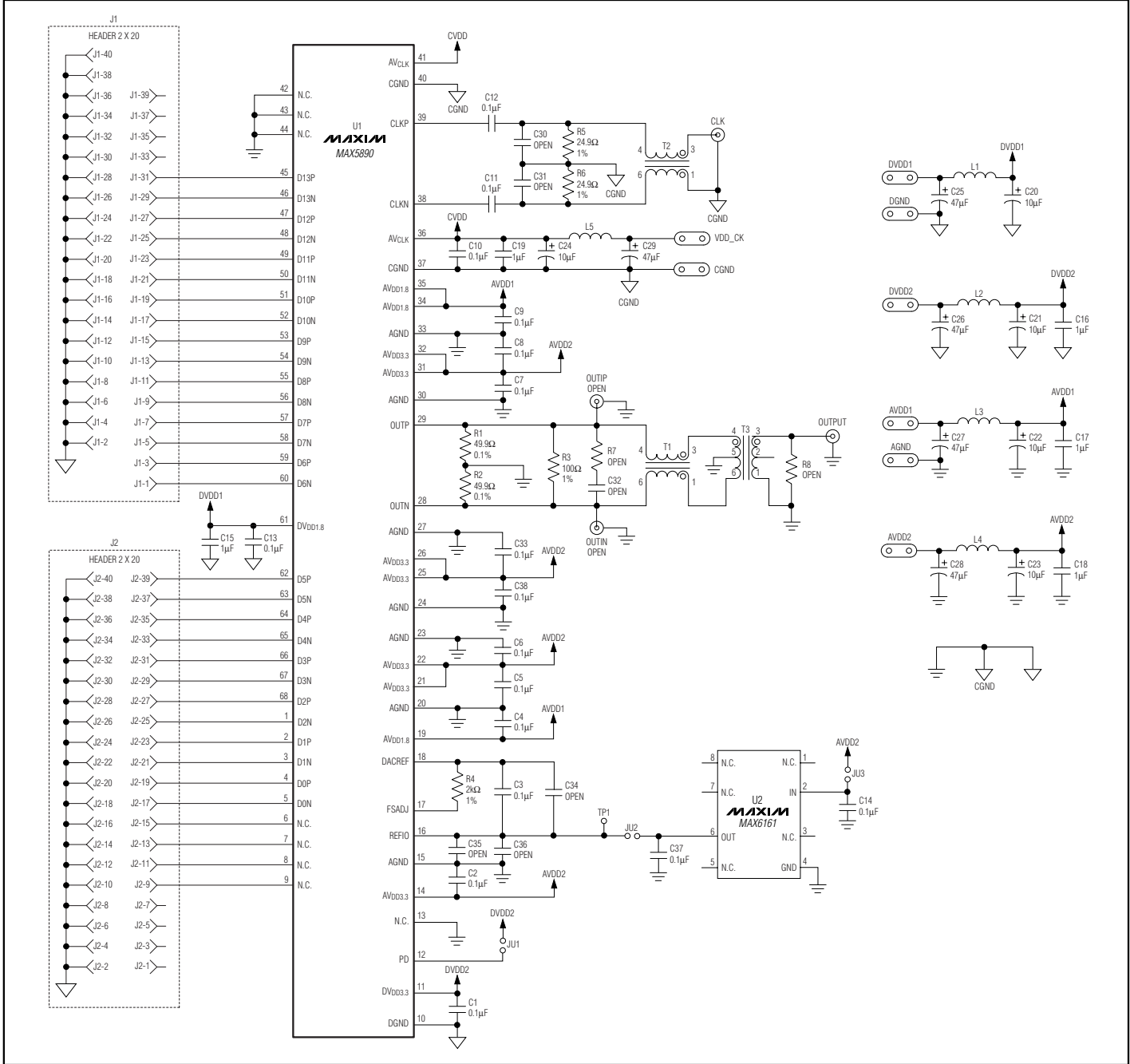

Figure 3. MAX5890 EV Kit Schematic

# MAX5889/MAX5890/MAX5891 Evaluation Kits

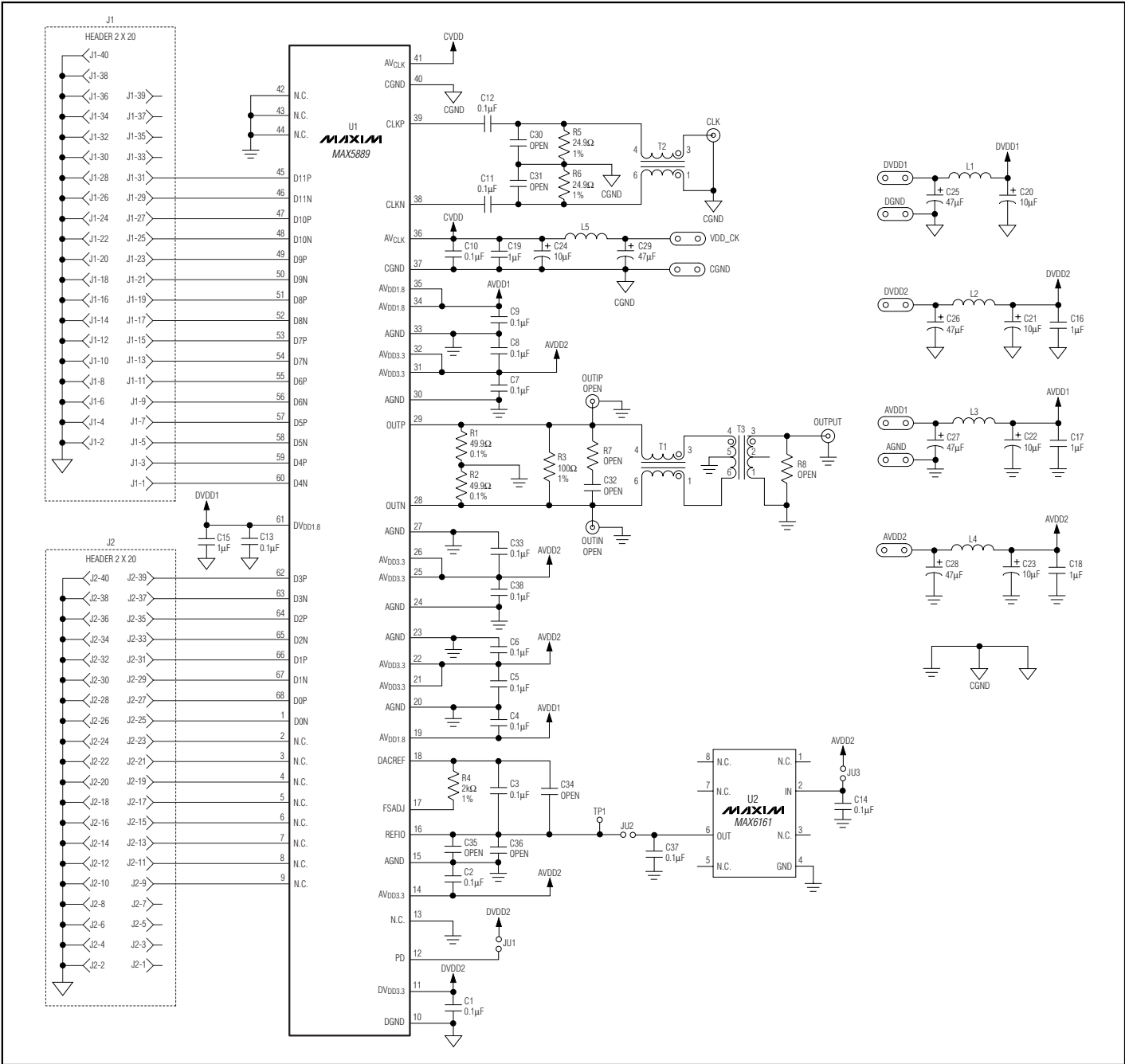

Figure 4. MAX5889 EV Kit Schematic

Evaluate: MAX5889/MAX5890/MAX5891

# MAX5889/MAX5890/MAX5891 Evaluation Kits

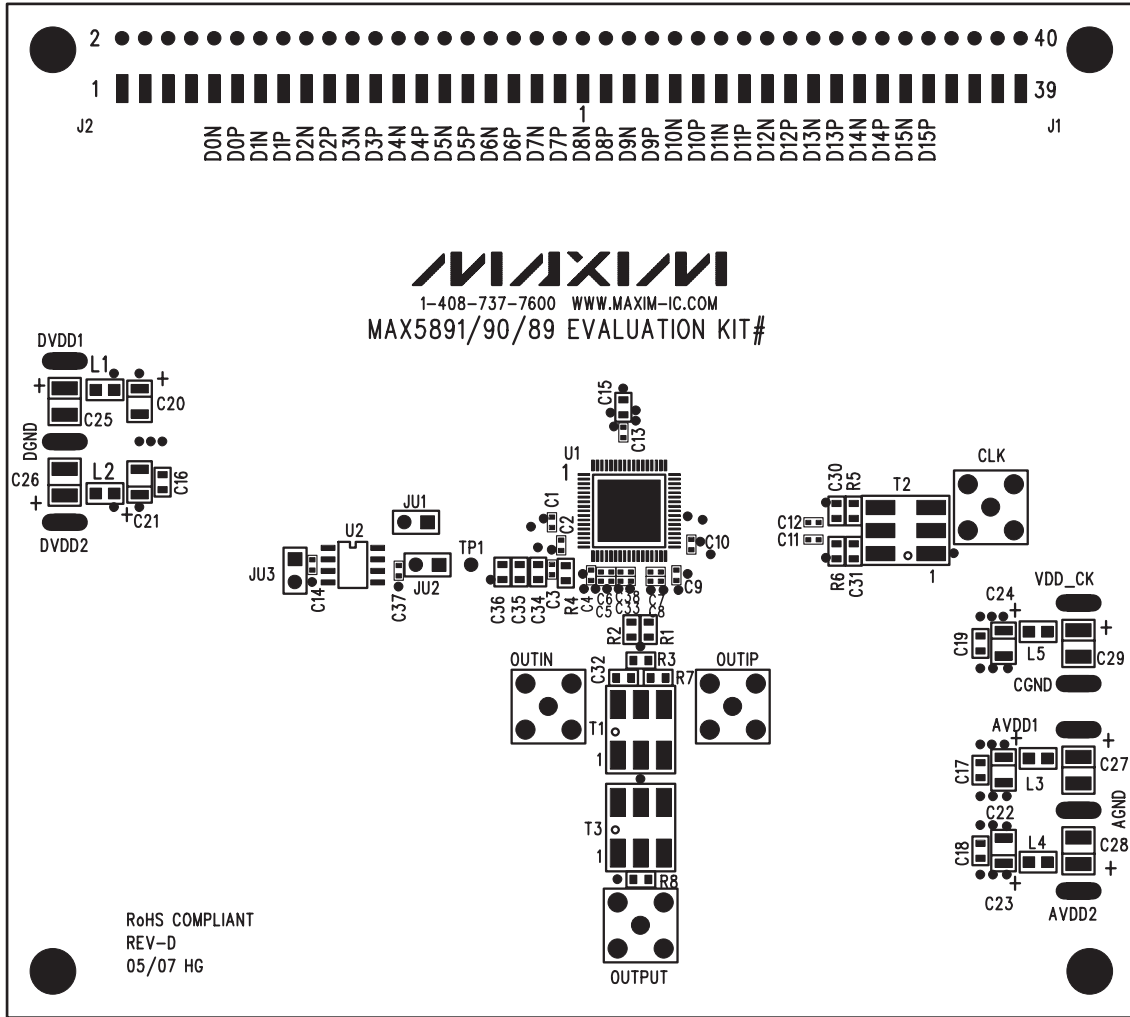

Figure 5. MAX5891/MAX5890/MAX5889 EV Kit Component Placement Guide—Component Side

# MAX5889/MAX5890/MAX5891 Evaluation Kits

Evaluate: MAX5889/MAX5890/MAX5891

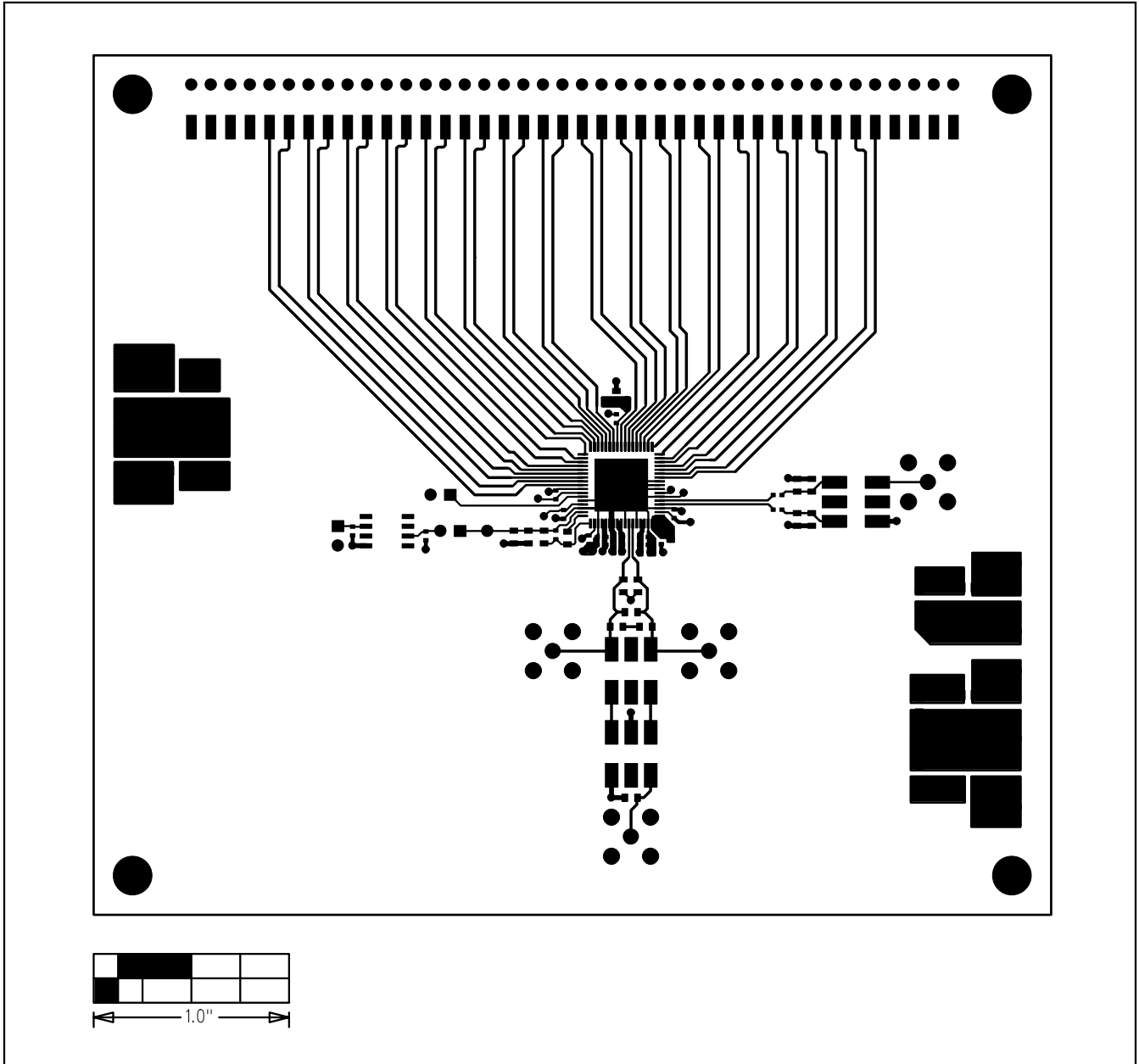

Figure 6. MAX5891/MAX5890/MAX5889 EV Kit PCB Layout—Component Side (Layer 1)

# MAX5889/MAX5890/MAX5891 Evaluation Kits

**Evaluate: MAX5889/MAX5890/MAX5891**

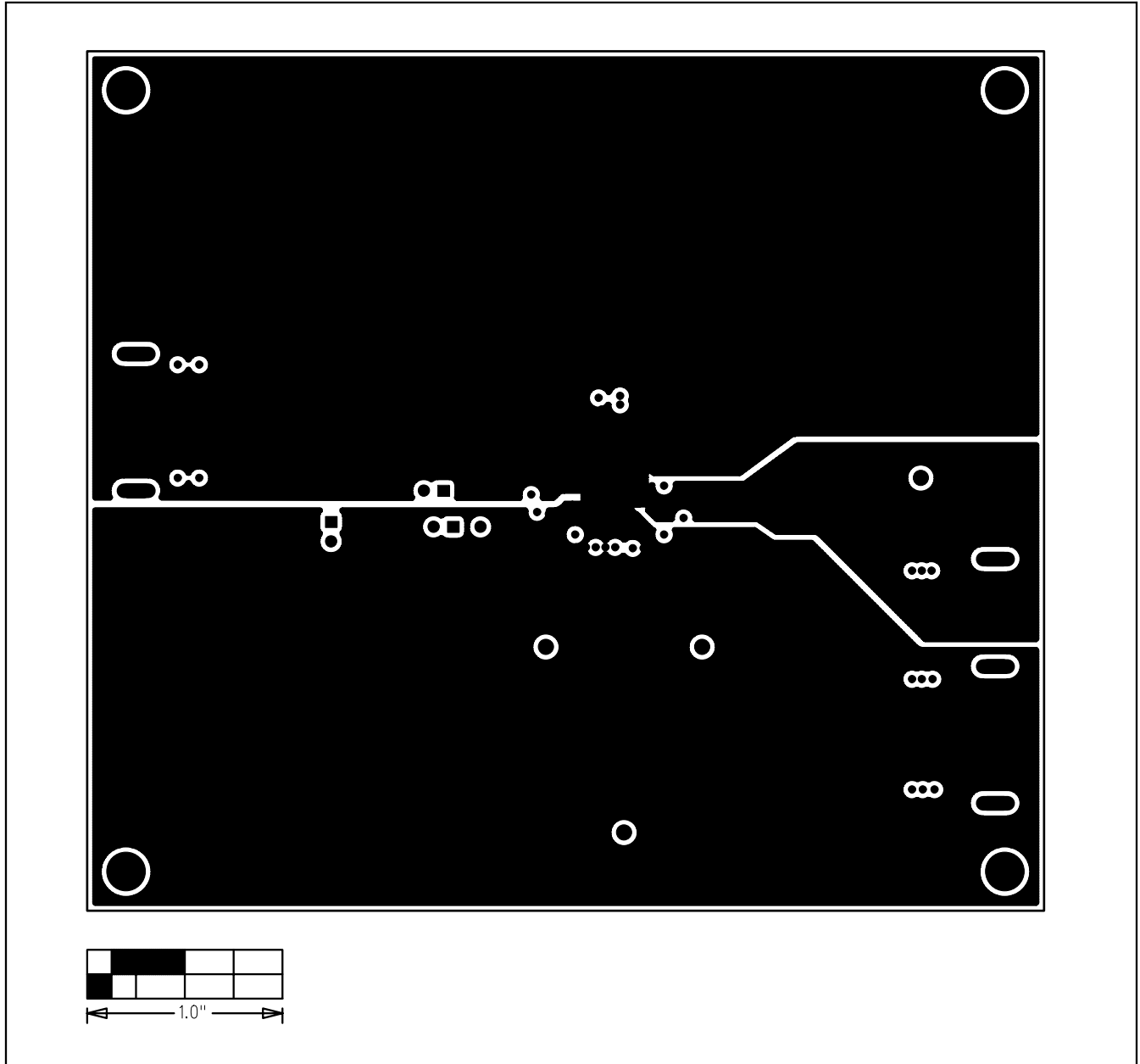

Figure 7. MAX5891/MAX5890/MAX5889 EV Kit PCB Layout—Ground Planes (Layer 2)

# MAX5889/MAX5890/MAX5891 Evaluation Kits

Evaluate: MAX5889/MAX5890/MAX5891

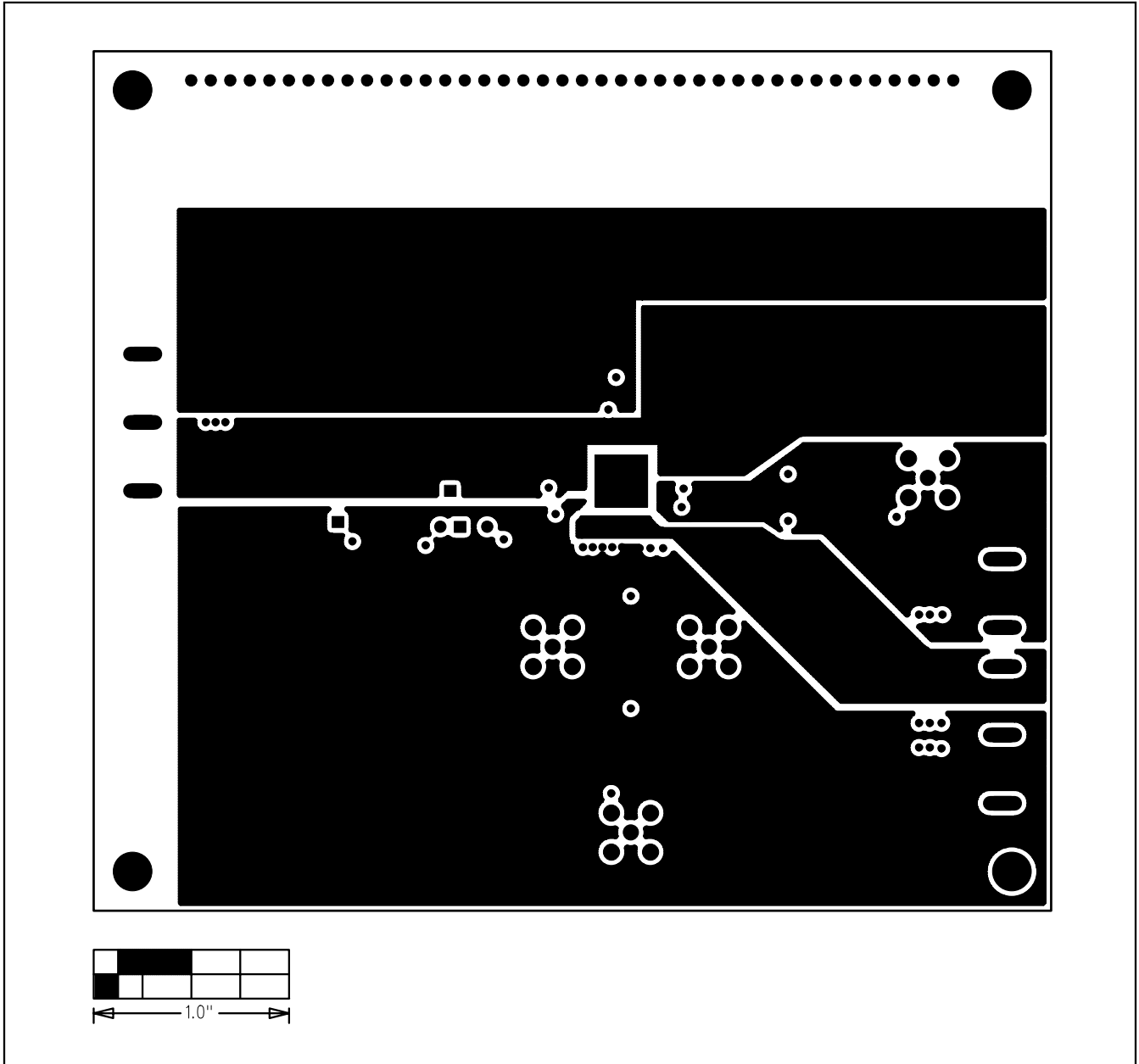

Figure 8. MAX5891/MAX5890/MAX5889 EV Kit PCB Layout—Power Planes (Layer 3)

# MAX5889/MAX5890/MAX5891 Evaluation Kits

**Evaluate: MAX5889/MAX5890/MAX5891**

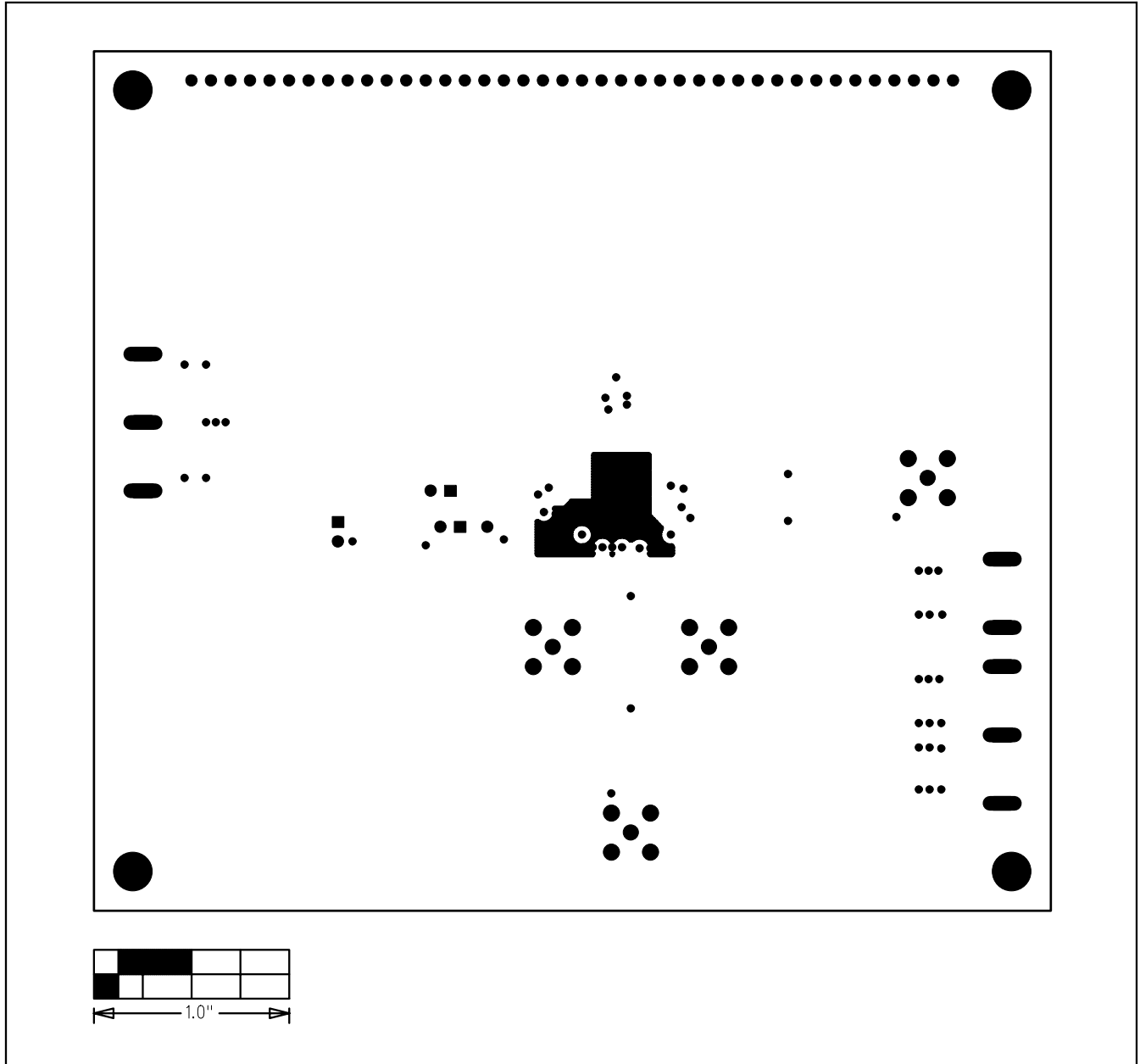

Figure 9. MAX5891/MAX5890/MAX5889 EV Kit PCB Layout—Solder Side (Layer 4)

## Revision History

Pages changed at Rev 1: 1–6, 10–14

Maxim cannot assume responsibility for use of any circuitry other than circuitry entirely embodied in a Maxim product. No circuit patent licenses are implied. Maxim reserves the right to change the circuitry and specifications without notice at any time.

14 **Maxim Integrated Products, 120 San Gabriel Drive, Sunnyvale, CA 94086 408-737-7600**

© 2007 Maxim Integrated Products

**MAXIM** is a registered trademark of Maxim Integrated Products, Inc.