



Chipsmall Limited consists of a professional team with an average of over 10 year of expertise in the distribution of electronic components. Based in Hongkong, we have already established firm and mutual-benefit business relationships with customers from,Europe,America and south Asia,supplying obsolete and hard-to-find components to meet their specific needs.

With the principle of “Quality Parts,Customers Priority,Honest Operation,and Considerate Service”,our business mainly focus on the distribution of electronic components. Line cards we deal with include Microchip,ALPS,ROHM,Xilinx,Pulse,ON,Everlight and Freescale. Main products comprise IC,Modules,Potentiometer,IC Socket,Relay,Connector.Our parts cover such applications as commercial,industrial, and automotives areas.

We are looking forward to setting up business relationship with you and hope to provide you with the best service and solution. Let us make a better world for our industry!



Contact us

Tel: +86-755-8981 8866 Fax: +86-755-8427 6832

Email & Skype: info@chipsmall.com Web: www.chipsmall.com

Address: A1208, Overseas Decoration Building, #122 Zhenhua RD., Futian, Shenzhen, China



General Description

The MAX6397 evaluation kit (EV kit) demonstrates a high-voltage overvoltage protection circuit for applications that must survive load dump and high-voltage transient conditions. This EV kit is a fully assembled and tested surface-mount board.

The EV kit supports high-output currents up to 5A, runs at voltages up to 72V, and can withstand temperatures ranging from -40°C to +105°C. Two alternate voltage inputs implement two different schemes for reverse-battery protection. Connections to the on-chip linear regulator, capable of driving 100mA, and the power-good (POK) signal are also provided.

Features

- 5.5V to 72V Wide Supply Voltage Range
- Up to 5A Output Current Capacity
- Selectable Overvoltage Mode and Overvoltage-Limiter Mode
- Adjustable Overvoltage Threshold
- 100V Reverse-Battery Protection
- Always-On Linear Regulator Output
- Power-Good Signal Output

Quick Start

Procedure

The MAX6397 EV kit is fully assembled and tested. Follow these steps to verify operation. **Do not turn on the power supply until all connections are completed.**

- 1) Connect a DC power supply (0 to 20V or above, 5A or depending on load) to VIN1 and GND.
- 2) Connect a voltmeter or oscilloscope and a load (if desired) to OUT and GND.
- 3) Make sure the J2 shunt connects pins 1 and 2 (overvoltage-protect mode). The J4 shunt should connect pins 1 and 2.
- 4) Turn on the power supply and increase the input voltage. The output turns on when the input voltage reaches 5.5V. Increase the supply voltage further; the output turns off when the input voltage reaches 17V.
- 5) The above steps can be followed for a power supply connected to VIN2 or VIN3. The thresholds for turn on and turn off for inputs VIN2 and VIN3 are higher due to the voltage drop across the reverse-battery protection.
- 6) Check the linear regulator output and POK signal.

Ordering Information

PART	TYPE
MAX6397EVKIT	EV Kit

Detailed Description

The MAX6397 EV kit demonstrates a high-voltage overvoltage-protection circuit for applications that must survive load dump and high-voltage transient conditions. This EV kit can be configured in overvoltage mode or overvoltage limiter mode by setting jumper J2 (see Table 1 for the jumper settings), and can supply up to 5A of output current.

The MAX6397 EV kit has three positive power-supply inputs: VIN1, VIN2, and VIN3. Inputs VIN2 and VIN3 have diode-based and p-channel MOSFET-based reverse-battery protections, respectively, and VIN1 bypasses all reverse-battery protections.

Overvoltage Mode

In overvoltage mode, the MAX6397 monitors the input voltage and turns off the series-pass n-channel MOSFET (M1) when the input voltage exceeds the programmed threshold voltage. As soon as the input voltage drops below the overvoltage threshold, the MAX6397 charge pump fully enhances MOSFET M1 to turn the output back on. The voltage-divider formed by R1 and R2 sets the threshold voltage. The resistors provided in the MAX6397 EV kit set the threshold at 17V. If inputs VIN2 or VIN3 are used, this threshold is higher due to the voltage drop in D1 or M2.

The overvoltage threshold can be adjusted by varying R1 or R2 using the equation below:

$$R1 = \left(\frac{V_{OV}}{1.215} - 1 \right) \times R2$$

where V_{OV} is the desired overvoltage threshold. To maintain threshold accuracy, R2 must be less than 250k Ω . Since the EV kit ships with R2 set at 49.9k Ω , use the formula above to change the threshold by changing R1 only.

Overvoltage-Limiter Mode

In overvoltage-limiter mode, the MAX6397 monitors the output voltage instead of the input voltage. The output voltage is sensed through the same voltage-divider formed by R1 and R2, so the equation given for overvoltage mode also applies to the threshold voltage in overvoltage limiter mode. During an input overvoltage transient in this mode, the MOSFET switches off until the output voltage falls to 95% of the threshold voltage, and then the MOSFET switches back on. This cycle repeats, generating a sawtooth waveform on the output.

The minimum output voltage in overvoltage-limiter mode depends on load current, output capacitance, and the MOSFET's switching period. The MAX6397 EV kit comes with one 22 μ F capacitor at the output to supply the load during the time when the MOSFET is off. Connect the optional electrolytic capacitor C13 (150 μ F, 100V) to support load currents higher than 0.5A when the EV kit operates in overvoltage limiter mode.

Add capacitor C3 on the gate of MOSFET M1 to decrease the frequency of the sawtooth waveform. This process helps limit the device's power dissipation.

Linear Regulator Output and Power-Good Signal

Connections are also included for the linear regulator output and the power-good (POK) signal. The linear regulator supplies up to 100mA at 5V, limited by the ambient temperature, the input/output voltages, and the package power dissipation. The POK signal has a 100k Ω resistor (R3) to the regulator output. The linear regulator is always on regardless of the state of SHDN.

Jumper Selection

To filter fast transients that may be present at the input from reaching the MAX6397, place a small resistor, R4, (10 Ω , for example) on the board, and cut jumper J1.

Three-pin jumper J2 selects between overvoltage mode and overvoltage limiter mode; do not leave this jumper unconnected. Three-pin jumper J3 controls the gate drive of p-channel MOSFET M3 used as a reverse-battery protection. Use J3 to disconnect resistor R5 when M3 is not used to avoid supply leakage through R5. Three-pin jumper J4 controls the SHDN pin of the MAX6397 and can enable or disable the MOSFET M1 enhancement. Table 1 lists the jumper options.

Table 1. Jumper Function

JUMPER	SHUNT POSITION AND FUNCTION	
	1 and 2	2 and 3
J1	Shorted: RC input filter disabled*	
J2	Overvoltage mode*	Overvoltage limiter mode
J3	M2 gate drive is disabled*	M2 gate drive is enabled
J4	U1 is enabled*	U1 is disabled

*Default position.

Component List

DESIGNATION	QTY	DESCRIPTION
C1, C7	2	22 μ F, 100V aluminum electrolytic capacitors Vishay 222215364229
C2, C8–C12	0	Not installed, capacitors
C3	0	Not installed, capacitor (1206)
C4	1	10 μ F, 10V X7R ceramic capacitor Murata GRM31CR71A106KA01B or TDK C3216X7R1C106K
C5	0	Not installed, capacitor (1206)
C6	1	0.1 μ F, 100V X7R ceramic capacitor TDK C3216X7R2A104K or AVX 12061C104KAT2A
C13	0	Not installed, 150 μ F/100V electrolytic capacitor Vishay BC Components 118AHT-222211829151 or Epcos B41693A9157Q009
D1	1	8A/100V Schottky diode International Rectifier 8TQ100S-IS or STMicroelectronics STPS8H100G
D2	1	60V, 600W TVS diode Diodes Inc. SMBJ54A or Fairchild SMBJ54A

DESIGNATION	QTY	DESCRIPTION
D3	1	18V zener diode Central Semi CMPZ5248B or Diodes Inc. MMBZ5248BT
D4	0	Not installed, optional TVS diode (DO-15)
J1	0	Not installed, 2-pin header
J2–J4	3	3-pin headers
M1	1	100V, 33A n-channel MOSFET International Rectifier IRF540NS or Fairchild FQB33N10
M2	1	100V, 23A p-channel MOSFET International Rectifier IRF9540NS or Fairchild FQB22P10
R1	1	649k Ω \pm 1% resistor (0805)
R2	1	49.9k Ω \pm 1% resistor (0805)
R3, R5	2	100k Ω \pm 1% resistors (0805)
R4	0	Not installed, resistor (0805)
R6	1	2.2M Ω \pm 1% resistor (0805)
U1	1	High-voltage overvoltage-protection circuit (8 TDFN-EP*) Maxim MAX6397LATA-T
—	1	PCB: MAX6397 EVALUATION KIT

*EP = Exposed pad.

Component Suppliers

SUPPLIER	PHONE	WEBSITE
AVX North America	864-967-2150	www.avx.com
Central Semiconductor	631-435-1110	www.centrasemi.com
Diodes Incorporated	805-446-4800	www.diodes.com
ECS	714-895-6351	www.ecsconn.com
EPCOS AG	732-906-4300	www.epcos.com
International Rectifier	310-322-3331	www.irf.com
Murata Americas	800-241-6574	www.murataamericas.com
STMicroelectronics	408-452-8585	www.us.st.com
TDK Corp.	847-803-6100	www.component.tdk.com
Vishay	402-563-6866	www.vishay.com

Note: Indicate you are using the MAX6397 when contacting these component suppliers.

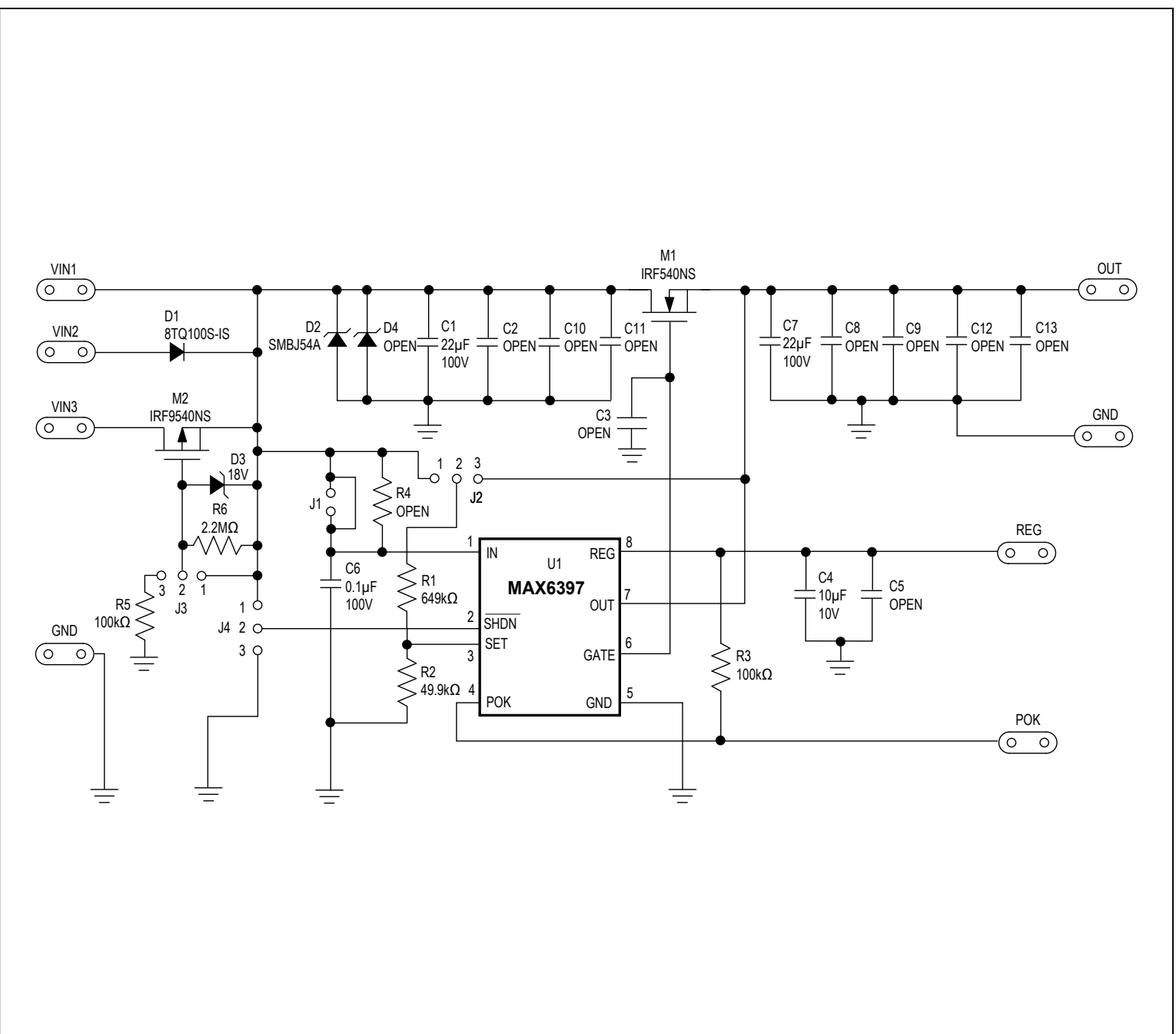

Figure 1. MAX6397 EV Kit Schematic

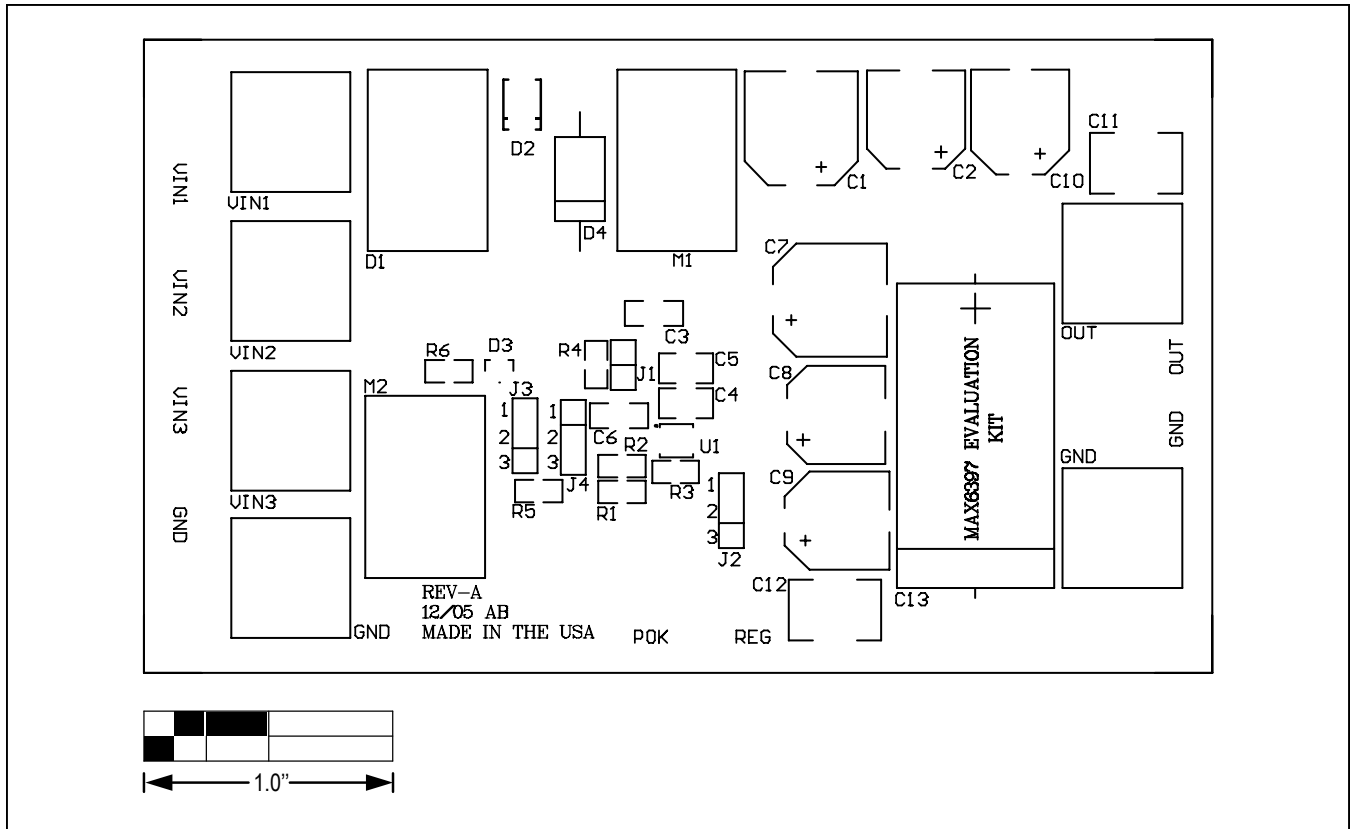

Figure 2. MAX6397 EV Kit Component Placement Guide—Component Side

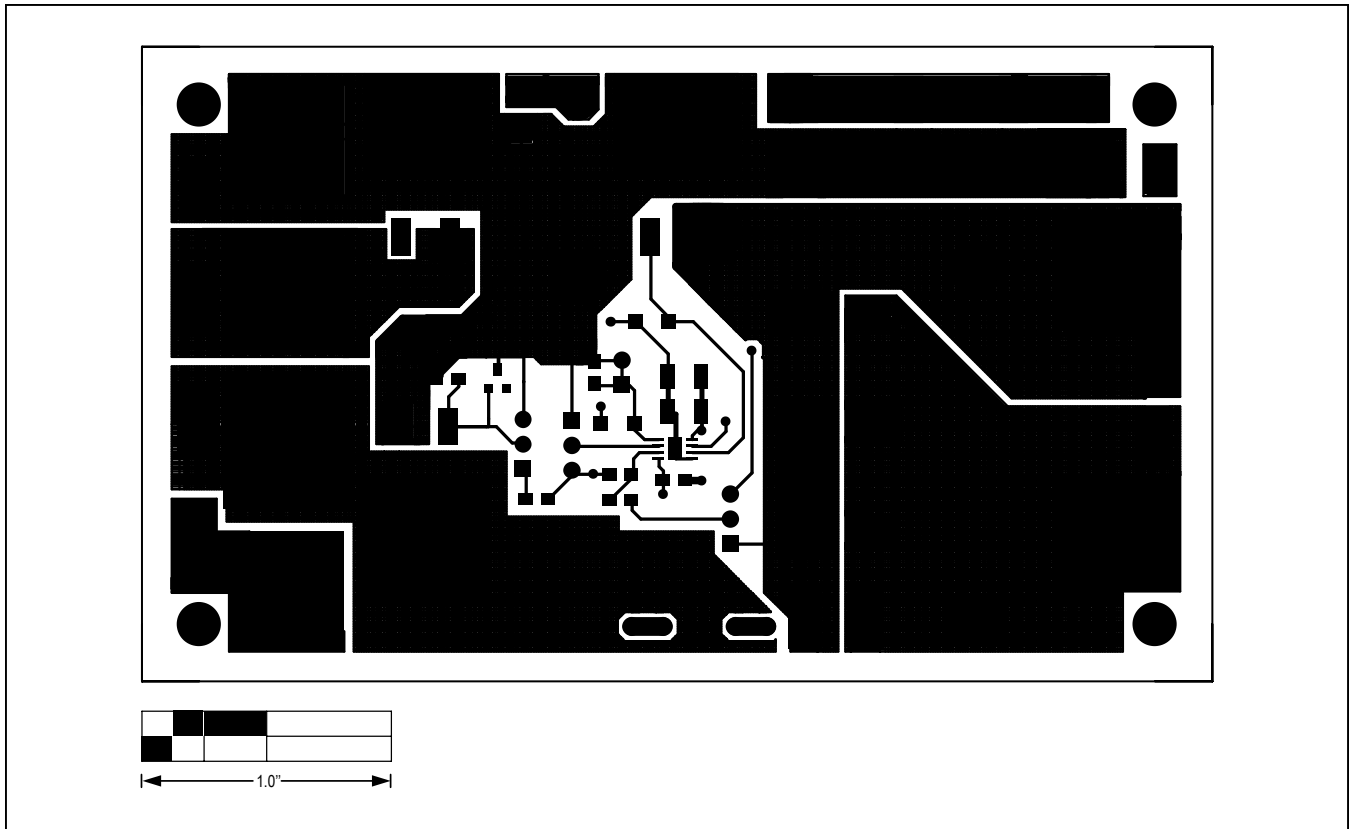

Figure 3. MAX6397 EV Kit PCB Layout—Component Side

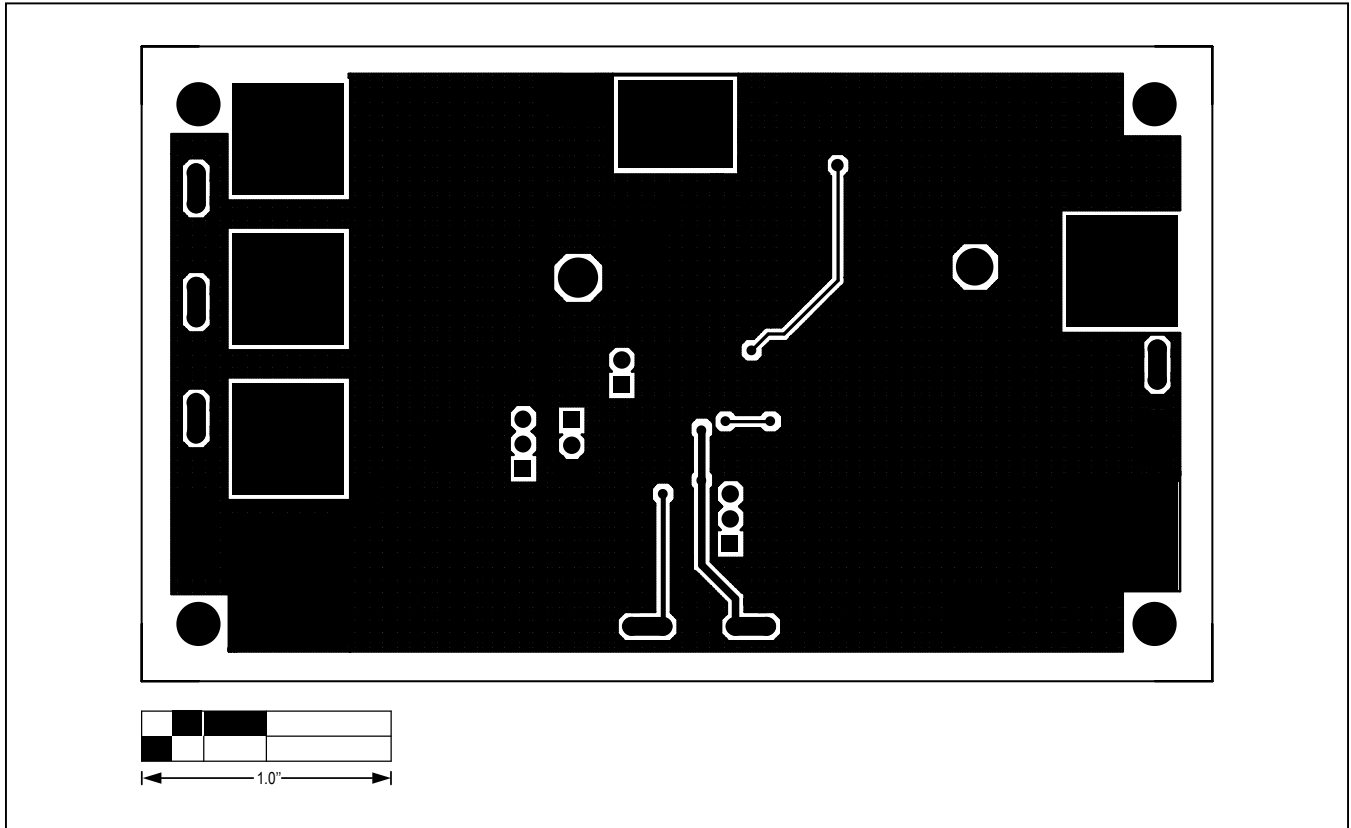

Figure 4. MAX6397 EV Kit PCB Layout—Solder Side

Revision History

REVISION NUMBER	REVISION DATE	DESCRIPTION	PAGES CHANGED
2	4/15	Deleted automotive reference in <i>General Description</i> and <i>Detailed Description</i> sections; moved <i>Component List</i> and <i>Component Suppliers</i> tables to page 3 and <i>Quick Start</i> section to page 1; added <i>Revision History</i> table	1, 2, 4, 8

For pricing, delivery, and ordering information, please contact Maxim Direct at 1-888-629-4642, or visit Maxim Integrated's website at www.maximintegrated.com.

Maxim Integrated cannot assume responsibility for use of any circuitry other than circuitry entirely embodied in a Maxim Integrated product. No circuit patent licenses are implied. Maxim Integrated reserves the right to change the circuitry and specifications without notice at any time.