



Chipsmall Limited consists of a professional team with an average of over 10 year of expertise in the distribution of electronic components. Based in Hongkong, we have already established firm and mutual-benefit business relationships with customers from,Europe,America and south Asia,supplying obsolete and hard-to-find components to meet their specific needs.

With the principle of “Quality Parts,Customers Priority,Honest Operation,and Considerate Service”,our business mainly focus on the distribution of electronic components. Line cards we deal with include Microchip,ALPS,ROHM,Xilinx,Pulse,ON,Everlight and Freescale. Main products comprise IC,Modules,Potentiometer,IC Socket,Relay,Connector.Our parts cover such applications as commercial,industrial, and automotives areas.

We are looking forward to setting up business relationship with you and hope to provide you with the best service and solution. Let us make a better world for our industry!



Contact us

Tel: +86-755-8981 8866 Fax: +86-755-8427 6832

Email & Skype: info@chipsmall.com Web: www.chipsmall.com

Address: A1208, Overseas Decoration Building, #122 Zhenhua RD., Futian, Shenzhen, China



General Description

The MAX6627/MAX6628 precise digital temperature sensors report the temperature of a remote sensor. The remote sensor is a diode-connected transistor, typically a low-cost, easily mounted 2N3904 NPN type that replaces conventional thermistors or thermocouples. The devices can also measure the die temperature of other ICs, such as microprocessors (μPs) or microcontrollers (μCs) that contain an on-chip, diode-connected transistor.

Remote accuracy is $\pm 1^\circ\text{C}$ when the temperature of the remote diode is between 0°C and $+125^\circ\text{C}$ and the temperature of the devices is $+30^\circ\text{C}$. The temperature is converted to a 12-bit + sign word with 0.0625°C resolution. The architecture of the device is capable of interpreting data as high as $+145^\circ\text{C}$ from the remote sensor. The MAX6627/MAX6628 temperature should never exceed $+125^\circ\text{C}$.

These sensors are 3-wire serial interface SPI-compatible, allowing the MAX6627/MAX6628 to be readily connected to a variety of μCs . The MAX6627/MAX6628 are read-only devices, simplifying their use in systems where only temperature data is required.

Two conversion rates are available, one that continuously converts data every 0.5s (MAX6627), and one that converts data every 8s (MAX6628). The slower version provides minimal power consumption under all operating conditions ($30\mu\text{A}$, typ). Either device can be read at any time and provide the data from the last conversion.

Both devices operate with supply voltages between $+3.0\text{V}$ and $+5.5\text{V}$, are specified between -55°C and $+125^\circ\text{C}$, and come in space-saving 8-pin SOT23 and lead-free TDFN packages.

Applications

- Hard Disk Drive
- Smart Battery Packs
- Industrial Control Systems
- Notebooks, PCs

Benefits and Features

- Accuracy
 - $\pm 1^\circ\text{C}$ (max) from $0^\circ\text{C} \leq T_{\text{RJ}} \leq +125^\circ\text{C}$, $T_{\text{A}} = +30^\circ\text{C}$
 - $\pm 2.4^\circ\text{C}$ (max) from $-55^\circ\text{C} \leq T_{\text{RJ}} \leq +100^\circ\text{C}$, $0^\circ\text{C} \leq T_{\text{A}} \leq +70^\circ\text{C}$
- 12-Bit + Sign, 0.0625°C Resolution
- Low Power Consumption
 - $30\mu\text{A}$ (typ) (MAX6628)
 - $200\mu\text{A}$ (typ) (MAX6627)
- Operating Temperature Range (-55°C to $+125^\circ\text{C}$)
- Measurement Temperature Range, Remote Junction (-55°C to $+145^\circ\text{C}$)
- 0.5s (MAX6627) or 8s (MAX6628) Conversion Rate
- SPI-Compatible Interface
- $+3.0\text{V}$ to $+5.5\text{V}$ Supply Range
- 8-Pin SOT23 and TDFN Packages
- Lead(Pb)-Free Version Available (TDFN Package)

Ordering Information appears at end of data sheet.

Typical Operating Circuit

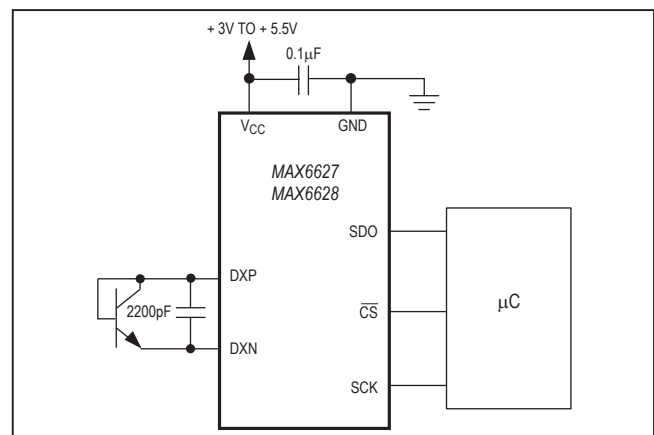

Absolute Maximum Ratings

(All voltages referenced to GND.)

V_{CC}.....-0.3V to +6V
 SDO, SCK, DXP, \overline{CS}-0.3V to (V_{CC} + 0.3V)
 DXN.....-0.3V to +0.8V
 SDO Pin Current Range.....-1mA to +50mA
 Current Into All Other Pins.....10mA
 ESD Protection (Human Body Model).....±2000V

Continuous Power Dissipation (T_A = +70°C)
 SOT23 (derate 9.7mW/°C above +70°C).....777mW
 TDFN (derate 18.5mW/°C above +70°C).....1481.5mW
 Operating Temperature Range.....-55°C to +125°C
 Junction Temperature.....+150°C
 Storage Temperature Range.....-65°C to +150°C
 Lead Temperature (soldering, 10s).....+300°C
 Soldering Temperature (reflow).....+260°C

Stresses beyond those listed under "Absolute Maximum Ratings" may cause permanent damage to the device. These are stress ratings only, and functional operation of the device at these or any other conditions beyond those indicated in the operational sections of the specifications is not implied. Exposure to absolute maximum rating conditions for extended periods may affect device reliability.

Electrical Characteristics

(3.0V ≤ V_{CC} ≤ 5.5V, -55°C ≤ T_A ≤ +125°C, unless otherwise noted. Typical values are at T_A = +25°C, V_{CC} = +3.3V, unless otherwise noted.)

PARAMETER	SYMBOL	CONDITIONS	MIN	TYP	MAX	UNITS
TEMPERATURE						
Accuracy (Note 1)		0°C ≤ T _{RJ} ≤ +125°C, T _A = +30°C, V _{CC} = +3.3V	-1.0	±0.5	±1	°C
		-55°C ≤ T _{RJ} ≤ +100°C, 0°C ≤ T _A ≤ +70°C, V _{CC} = +3.3V	-2.4		+2.4	
		-55°C ≤ T _{RJ} ≤ +145°C, 0°C ≤ T _A ≤ +70°C, V _{CC} = +3.3V	-4.5		+4.5	
		-55°C ≤ T _{RJ} ≤ +125°C, -55°C ≤ T _A ≤ +125°C, V _{CC} = +3.3V	-5.5		+5.5	
Power-Supply Sensitivity				0.25	0.7	°C/V
Resolution				0.0625		°C
Time Between Conversion Starts	t _{SAMPLE}	MAX6627		0.5		s
		MAX6628		8		
Conversion Time	t _{CONV}		180	250	320	ms
POWER SUPPLY						
Supply Voltage Range	V _{CC}		3.0		5.5	V
Supply Current, SCK Idle	I _{SDO}	Shutdown, V _{CC} = +0.8V			5	μA
	I _{IDLE}	ADC idle, \overline{CS} = low			20	
	I _{CONV}	ADC converting		360	600	
Average Operating Current	I _{CC}	MAX6627		200	400	μA
		MAX6628		30	50	
Power-On Reset (POR) Threshold		V _{CC} , falling edge		1.6		V
Current Sourcing for Diode		High level	80	100	120	μA
		Low level	8	10	12	

Electrical Characteristics (continued)

($3.0\text{V} \leq V_{\text{CC}} \leq 5.5\text{V}$, $-55^{\circ}\text{C} \leq T_{\text{A}} \leq +125^{\circ}\text{C}$, unless otherwise noted. Typical values are at $T_{\text{A}} = +25^{\circ}\text{C}$, $V_{\text{CC}} = +3.3\text{V}$, unless otherwise noted.)

PARAMETER	SYMBOL	CONDITIONS	MIN	TYP	MAX	UNITS
LOGIC INPUTS ($\overline{\text{CS}}$, SCK)						
Logic Input Low Voltage	V_{IL}				$0.3 \times V_{\text{CC}}$	V
Logic Input High Voltage	V_{IH}		$0.7 \times V_{\text{CC}}$			V
Input Leakage Current	I_{LEAK}	$V_{\text{CS}} = V_{\text{SCK}} = \text{GND or } V_{\text{CC}}$			1	μA
LOGIC OUTPUTS (SDO)						
Output Low Voltage	V_{OL}	$I_{\text{SINK}} = 1.6\text{mA}$			0.4	
Output High Voltage	V_{OH}	$I_{\text{SOURCE}} = 1.6\text{mA}$	$V_{\text{CC}} - 0.4$			V
TIMING CHARACTERISTICS (Note 2, Figure 2)						
Serial-Clock Frequency	f_{SCL}				5	MHz
SCK Pulse Width High	t_{CH}		100			ns
SCK Pulse Width Low	t_{CL}		100			ns
$\overline{\text{CS}}$ Fall to SCK Rise	t_{CSS}	$C_{\text{LOAD}} = 10\text{pF}$	80			ns
$\overline{\text{CS}}$ Fall to Output Enable	t_{DV}	$C_{\text{LOAD}} = 10\text{pF}$			80	ns
$\overline{\text{CS}}$ Rise to Output Disable	t_{TR}	$C_{\text{LOAD}} = 10\text{pF}$			50	ns
SCK Fall to Output Data Valid	t_{DO}	$C_{\text{LOAD}} = 10\text{pF}$			80	ns

Note 1: T_{RJ} is the temperature of the remote junction.

Note 2: Serial timing characteristics guaranteed by design.

Typical Operating Characteristics

($V_{CC} = +3.3\text{V}$, $T_A = +25^\circ\text{C}$, unless otherwise noted.)

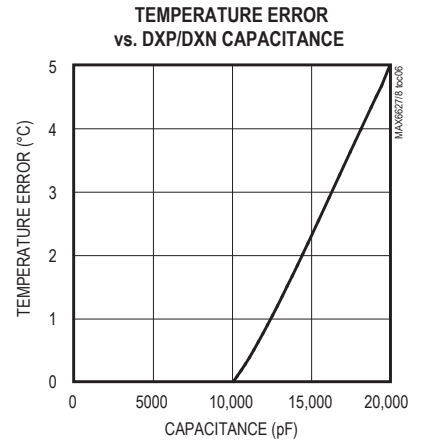
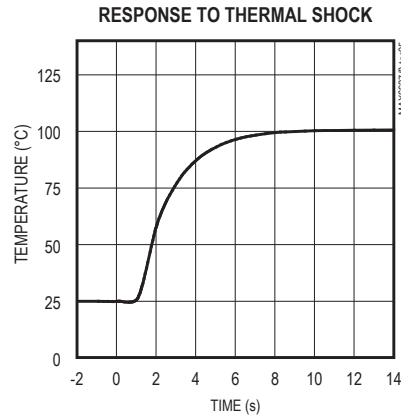
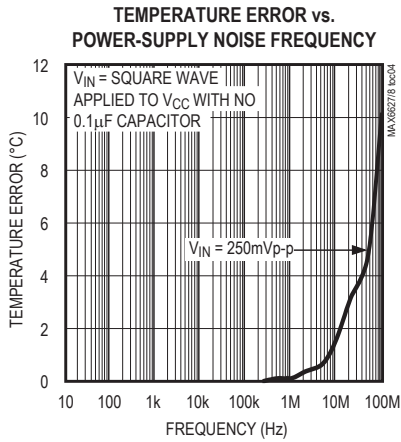
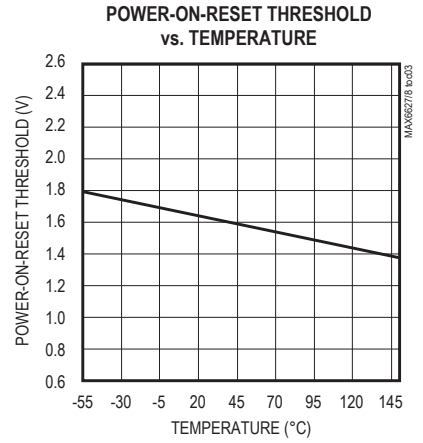
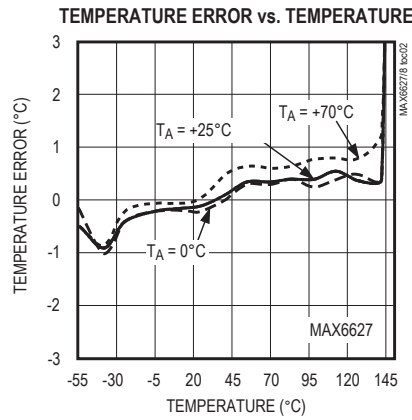
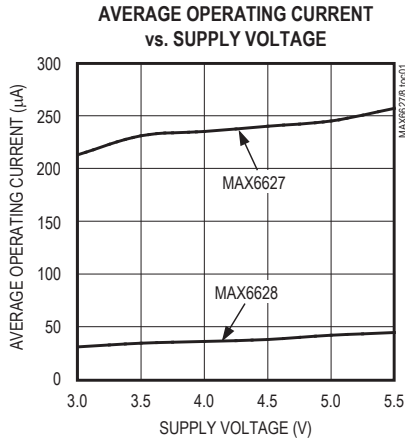

Pin Configurations

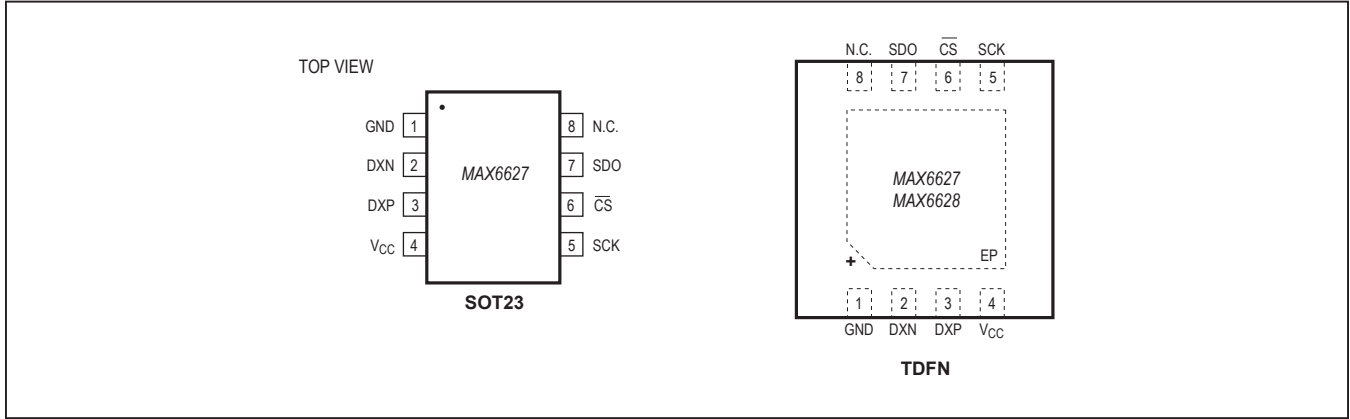

Pin Description

PIN	NAME	FUNCTION
1	GND	Ground
2	DXN	Combined Current Sink and ADC Negative Input for Remote Diode. DXN is normally biased to a diode voltage above ground.
3	DXP	Combined Current Source and ADC Positive Input for Remote Diode. Place a 2200pF capacitor between DXP and DXN for noise filtering.
4	VCC	Supply Voltage Input. Bypass with a 0.1µF to GND.
5	SCK	SPI Clock Input
6	CS	Chip-Select Input. Pulling CS low initiates an idle state, but the SPI interface is still enabled. A rising-edge of CS initiates the next conversion.
7	SDO	SPI Data Output
8	N.C.	No Connect. Internally not connected. Can be connected to GND for improved thermal conductivity.
—	EP	Exposed Pad. Internally connected to GND. Connect to a large ground plane to maximize thermal performance. Not intended as an electrical connection point.

Detailed Description

The MAX6627/MAX6628 remote digital thermometers report the temperature of a remote sensor. The remote sensor is a diode-connected transistor—typically, a low-cost, easily mounted 2N3904 NPN type—that replaces conventional thermistors or thermocouples. These devices can also measure the die temperature of other ICs, such as μ Ps or μ Cs, that contain an on-chip, diode-connected transistor.

Remote accuracy is $\pm 1^\circ\text{C}$ when the temperature of the remote diode is between 0°C and $+125^\circ\text{C}$ and the temperature of the MAX6627/MAX6628 is $+30^\circ\text{C}$. Data is available as a 12-bit + sign word with 0.0625°C resolution. The operating range of the device extends from -55°C to $+125^\circ\text{C}$, although the architecture of the device is capable of interpreting data up to $+145^\circ\text{C}$. The device itself should never exceed $+125^\circ\text{C}$.

The devices are designed to work in conjunction with an external μ C or other intelligent device serving as the master in thermostatic, process-control, or monitoring applications. The μ C is typically a power management or keyboard controller, generating SPI serial commands by “bit-banging” GPIO pins.

Two conversion rates are available; the MAX6627 continuously converts data every 0.5s, and the MAX6628 continuously converts data every 8s. Either device can be read at any time and provide the data from the last conversion. The slower version provides minimal power consumption under all operating conditions. Or, by

taking $\overline{\text{CS}}$ low, any conversion in progress is stopped, and the rising-edge of $\overline{\text{CS}}$ always starts a fresh conversion and resets the interface. This permits triggering a conversion at any time so that the power consumption of the MAX6627 can be overcome, if needed. Both devices operate with input voltages between +3.0V and +5.5V and are specified between -55°C and $+125^\circ\text{C}$. The MAX6627/MAX6628 come in space-saving 8-pin SOT23 and TDFN packages.

ADC Conversion Sequence

The device powers up as a free-running data converter (Figure 1). The $\overline{\text{CS}}$ pin can be used for conversion control. The rising-edge of $\overline{\text{CS}}$ resets the interface and starts a conversion. The falling-edge of $\overline{\text{CS}}$ stops any conversion in progress, overriding the latency of the part. Temperature data from the previous completed conversion is available for read (Table 1 and Table 2). It is required to maintain $\overline{\text{CS}}$ high for a minimum of 320ms to complete a conversion.

Idle Mode

Pull $\overline{\text{CS}}$ low to enter idle mode. In idle mode, the ADC is not converting. The serial interface is still active and temperature data from the last completed conversion can still be read.

Power-On Reset

The POR supply voltage of the MAX6627/MAX6628 is typically 1.6V. Below this supply voltage, the interface is inactive and the data register is set to the POR state,

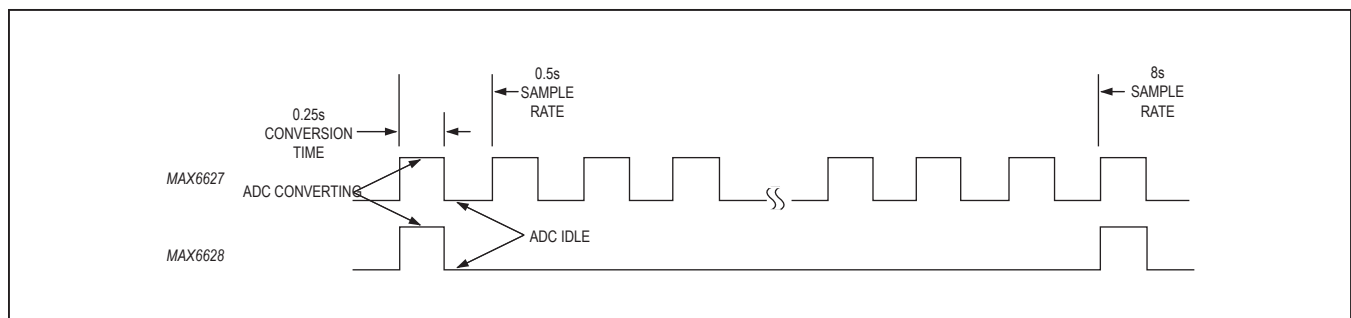

Figure 1. Free-Running Conversion Time and Rate Relationships

Table 1. Data Output Format

D15	D14	D13	D12	D11	D10	D9	D8	D7	D6	D5	D4	D3	D2	D1	D0
Sign	MSB Data											LSB Data	Low	High-Z	High-Z

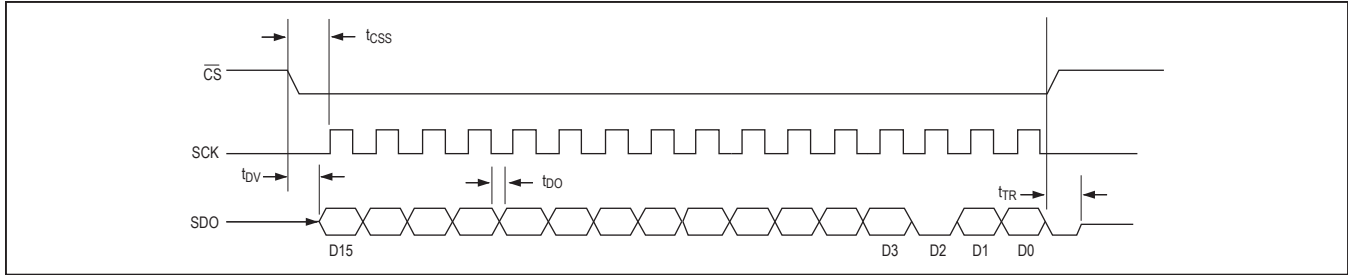

Figure 2. SPI Timing Diagram

Table 2. Temperature Data Format (Two’s Complement)

TEMPERATURE (°C)	DIGITAL OUTPUT (BINARY)		
	D15–D3	D2	D1, D0
150	0,1001,0110,0000	0	XX
125	0,0111,1101,0000	0	XX
25	0,0001,1001,0000	0	XX
0.0625	0,0000,0000,0001	0	XX
0	0,0000,0000,0000	0	XX
-0.0625	1,1111,1111,1111	0	XX
-25	1,1110,0111,0000	0	XX
-55	1,1100,1001,0000	0	XX

0°C. When power is first applied and V_{CC} rises above 1.6V (typ), the device starts to convert, although temperature reading is not recommended at V_{CC} levels below 3.0V.

Serial Interface

Figure 2 is the serial interface timing diagram. The data is latched into the shift register on the falling-edge of the CS signal and then clocked out at the SDO pin on the falling-edge of SCK with the most-significant bit (MSB) first. There are 16 edges of data per frame. The last 2 bits, D0 and D1, are always in high-impedance mode. The falling-edge of CS stops any conversion in progress, and the rising-edge of CS always starts a new conversion and resets the interface. It is required to maintain a 320ms minimum pulse width of high CS signal before a conversion starts.

Applications Information

Remote-Diode Selection

Temperature accuracy depends upon having a good-quality, diode-connected, small-signal transistor. Accuracy has been experimentally verified for all of the devices listed

in Table 3. The MAX6627/MAX6628 can also directly measure the die temperature of CPUs and other ICs with on-board temperature-sensing diodes.

The transistor must be a small-signal type with a relatively high forward voltage. This ensures that the input voltage is within the A/D input voltage range. The forward voltage must be greater than 0.25V at 10µA at the highest expected temperature. The forward voltage must be less than 0.95V at 100µA at the lowest expected temperature. The base resistance has to be less than 100Ω. Tight specification of forward-current gain (+50 to +150, for example) indicates that the manufacturer has good process control and that the devices have consistent characteristics.

ADC Noise Filtering

The integrating ADC has inherently good noise rejection, especially of low-frequency signals such as 60Hz/120Hz power-supply hum. Micropower operation places constraints on high-frequency noise rejection. Lay out the PCB carefully with proper external noise filtering for high-accuracy remote measurements in electrically noisy environments.

Table 3. SOT23-Type Remote-Sensor Transistor Manufacturers

MANUFACTURER	MODEL
Central Semiconductor (USA)	CMPT3904
Motorola (USA)	MMBT3904
Rohm Semiconductor (Japan)	SST3904
Siemens (Germany)	SMBT3904
Zetex (England)	FMMT3904CT-ND

Note: Transistors must be diode connected (Short the Base to the Collector).

Filter high-frequency electromagnetic interference (EMI) at DXP and DXN with an external 2200pF capacitor connected between the two inputs. This capacitor can be increased to about 3300pF (max), including cable capacitance. A capacitance higher than 3300pF introduces errors due to the rise time of the switched-current source.

PCB Layout

- 1) Place the MAX6627/MAX6628 as close as practical to the remote diode. In a noisy environment, such as a computer motherboard, this distance can be 4in to 8in, or more, as long as the worst noise sources (such as CRTs, clock generators, memory buses, and ISA/PCI buses) are avoided.
- 2) Do not route the DXP/DXN lines next to the deflection coils of a CRT. Also, do not route the traces across a fast memory bus, which can easily introduce $+30^{\circ}\text{C}$ error, even with good filtering. Otherwise, most noise sources are fairly benign.
- 3) Route the DXP and DXN traces parallel and close to each other, away from any high-voltage traces such as +12VDC. Avoid leakage currents from PCB contamination. A $20\text{M}\Omega$ leakage path from DXP to ground causes approximately $+1^{\circ}\text{C}$ error.
- 4) Connect guard traces to GND on either side of the DXP/DXN traces (Figure 3). With guard traces in place, routing near high-voltage traces is no longer an issue.
- 5) Route as few vias and crossunders as possible to minimize copper/solder thermocouple effects.
- 6) When introducing a thermocouple, make sure that both the DXP and the DXN paths have matching thermocouples. In general, PCB-induced thermocouples are not a serious problem. A copper solder thermocouple exhibits $3\mu\text{V}/^{\circ}\text{C}$, and it takes approximately $200\mu\text{V}$ of voltage error at DXP/DXN to cause a $+1^{\circ}\text{C}$ measurement error, so most parasitic thermocouple errors are swamped out.
- 7) Use wide traces. Narrow traces are more inductive and tend to pick up radiated noise. The 10mil

widths and spacings recommended in Figure 3 are not absolutely necessary (as they offer only a minor improvement in leakage and noise), but use them where practical.

- 8) Placing an electrically clean copper ground plane between the DXP/DXN traces and traces carrying high-frequency noise signals helps reduce EMI.

Twisted Pair and Shielded Cables

For remote-sensor distances longer than 8in, or in particularly noisy environments, a twisted pair is recommended. Its practical length is 6ft to 12ft (typ) before noise becomes a problem, as tested in a noisy electronics laboratory. For longer distances, the best solution is a shielded twisted pair like that used for audio microphones. For example, Belden #8451 works well for distances up to 100ft in a noisy environment. Connect the twisted pair to DXP and DXN and the shield to ground, and leave the shield's remote end unterminated. Excess capacitance at DXN or DXP limits practical remote-sensor distances (see [Typical Operating Characteristics](#)).

For very long cable runs, the cable's parasitic capacitance often provides noise filtering, so the recommended 2200pF capacitor can often be removed or reduced in value. Cable resistance also affects remote-sensor accuracy. A 1Ω series resistance introduces about $+1/2^{\circ}\text{C}$ error.

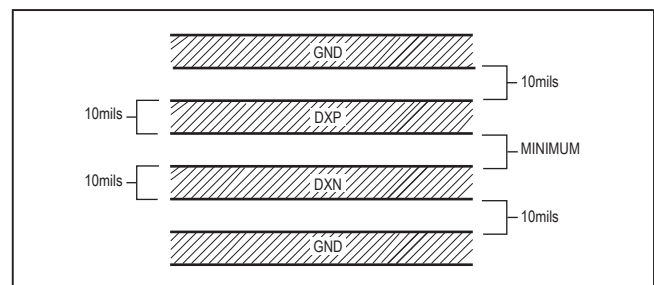
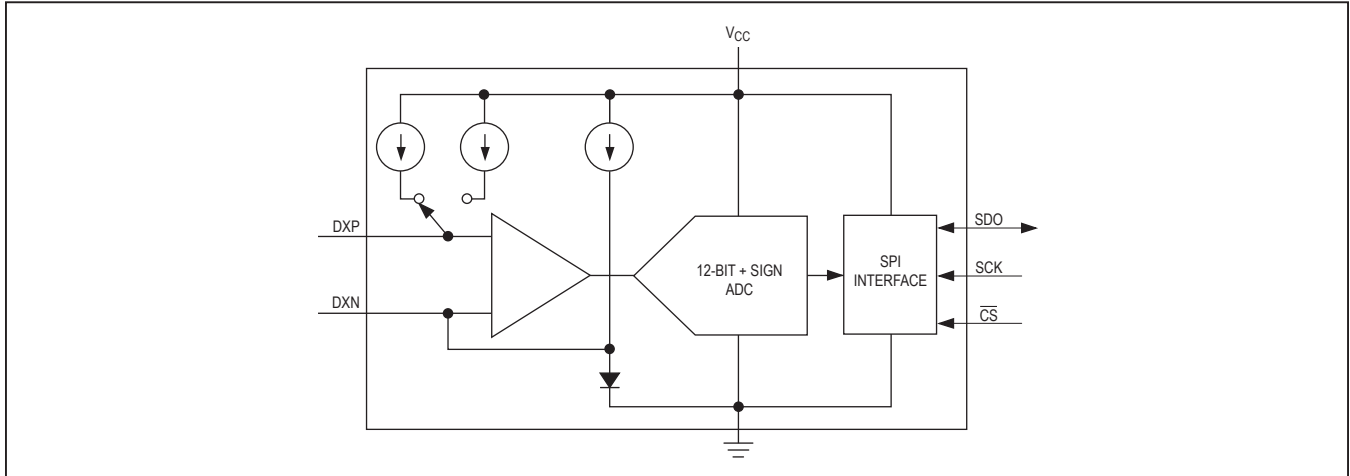

Figure 3. Recommended DXP/DXN PCB Traces

Functional Diagram



Ordering Information

PART	PIN-PACKAGE	TOP MARK
MAX6627MKA#TG16	8 SOT23	AEQD
MAX6627MTA+T	8 TDFN-EP*	AUT
MAX6628MKA+T	8 SOT23	AAER
MAX6628MTA+T	8 TDFN-EP*	AUU

Note: All devices are specified over the -55°C to +125°C operating temperature range.
 #Denotes a RoHS-compliant device that may include lead(Pb) that is exempt under the RoHS requirements.
 +Denotes a lead-free/RoHS-compliant package.
 T = Tape and reel.
 *EP = Exposed pad.

Package Information

For the latest package outline information and land patterns (footprints), go to www.maximintegrated.com/packages. Note that a "+", "#", or "-" in the package code indicates RoHS status only. Package drawings may show a different suffix character, but the drawing pertains to the package regardless of RoHS status.

PACKAGE TYPE	PACKAGE CODE	OUTLINE NO.	LAND PATTERN NO.
8 SOT23	K8FH#4	21-0078	90-0176
8 TDFN-EP	T833+2	21-0137	90-0059

Chip Information

PROCESS: BICMOS

Revision History

REVISION NUMBER	REVISION DATE	DESCRIPTION	PAGES CHANGED
0	4/01	Initial release	—
1	7/01	Removed future status from the MAX6628; changed I_{CONV} from 600 μA (max) to 650 μA (max) in the <i>Electrical Characteristics</i> table; replaced TOC1 in the <i>Typical Operating Characteristics</i> section	1, 2, 4
2	4/04	Updated the lead temperature information in the <i>Absolute Maximum Ratings</i> section; updated the notes for the <i>Electrical Characteristics</i> table	2, 3
3	4/06	Added the TDFN package; updated Table 3; removed transistor count from the <i>Chip Information</i> section	1, 2, 5, 6, 7, 8, 10
4	8/08	Added missing exposed pad description, updated ordering part numbers, and updated pin name for pin 7	1–4, 6, 8–11
5	6/11	Corrected the top mark information and SOT23 part number in the <i>Ordering Information</i> table; added the soldering information to the <i>Absolute Maximum Ratings</i> section; added the land pattern numbers to the <i>Package Information</i> table	1, 2, 8
6	4/14	Updated <i>Applications</i>	1
7	3/16	Adding MAX6628MKA+ to <i>Ordering Information</i> table	8

For pricing, delivery, and ordering information, please contact Maxim Direct at 1-888-629-4642, or visit Maxim Integrated's website at www.maximintegrated.com.

Maxim Integrated cannot assume responsibility for use of any circuitry other than circuitry entirely embodied in a Maxim Integrated product. No circuit patent licenses are implied. Maxim Integrated reserves the right to change the circuitry and specifications without notice at any time. The parametric values (min and max limits) shown in the *Electrical Characteristics* table are guaranteed. Other parametric values quoted in this data sheet are provided for guidance.