



Chipsmall Limited consists of a professional team with an average of over 10 year of expertise in the distribution of electronic components. Based in Hongkong, we have already established firm and mutual-benefit business relationships with customers from,Europe,America and south Asia,supplying obsolete and hard-to-find components to meet their specific needs.

With the principle of "Quality Parts,Customers Priority,Honest Operation,and Considerate Service",our business mainly focus on the distribution of electronic components. Line cards we deal with include Microchip,ALPS,ROHM,Xilinx,Pulse,ON,Everlight and Freescale. Main products comprise IC,Modules,Potentiometer,IC Socket,Relay,Connector.Our parts cover such applications as commercial,industrial, and automotives areas.

We are looking forward to setting up business relationship with you and hope to provide you with the best service and solution. Let us make a better world for our industry!



Contact us

Tel: +86-755-8981 8866 Fax: +86-755-8427 6832

Email & Skype: info@chipsmall.com Web: www.chipsmall.com

Address: A1208, Overseas Decoration Building, #122 Zhenhua RD., Futian, Shenzhen, China





MAX6791 Evaluation Kit

General Description

The MAX6791 evaluation kit (EV kit) provides a proven PC board layout that facilitates evaluation of the MAX6791 high-voltage, low-quiescent-current dual linear regulator. The EV kit can also evaluate the MAX6792–MAX6796. This EV kit is a fully assembled and tested surface-mount board.

This EV kit includes an on-board p-channel FET for reverse-battery protection, a button to allow testing of the regulator hold feature, and connections to both regulators, the windowed watchdog timer, and the μP reset line. Two LEDs indicate the status of both voltage regulators. Jumpers provide control over all major features of the MAX6791. The EV kit operates at temperatures ranging from -40°C to $+105^{\circ}\text{C}$, although the MAX6791 itself can withstand temperatures up to $+125^{\circ}\text{C}$.

Features

- ◆ Wide 5V to 72V Supply Voltage Range
- ◆ 100V Reverse-Battery Protection
- ◆ Dual 150mA Regulator Outputs
- ◆ Fixed or Adjustable Regulator Output
- ◆ Windowed Watchdog Timer
- ◆ ENABLE and HOLD Functions

Ordering Information

PART	TEMP RANGE	IC PACKAGE
MAX6791EVKIT	-40°C to $+105^{\circ}\text{C}$	20 TQFN-EP*

*EP = Exposed pad.

Component List

DESIGNATION	QTY	DESCRIPTION
C1**	0	Optional switch debounce capacitor
C2**	0	Optional OUT1 capacitor (1812)
C3, C8	2	10 μF $\pm 20\%$, 16V X7R ceramic capacitors (1210) TDK C3225X7R1C106M
C4	1	1500pF $\pm 10\%$, 50V X7R ceramic capacitor (0603) TDK C1608X7R1H152K
C5	1	0.022 μF $\pm 10\%$, 16V X7R ceramic capacitor (0603) TDK C1608X7R1H223K
C6	1	1 μF $\pm 20\%$, 100V X7R ceramic capacitor (1812) TDK C4532X7R2A105M
C7**	0	Optional input capacitor (10 μF , 100V) Vishay 222215369109
C9**	0	Optional OUT2 capacitor (1812)
D1**	0	Optional transient voltage suppressor Vishay SMBJ51A

DESIGNATION	QTY	DESCRIPTION
LED1, LED2	2	Green LEDs (1206)
J1, J2, J4, J5, J8–J12	9	2-pin headers
J3, J6, J7	3	3-pin headers
Q1	1	p-channel FET IRF IRFR9110
R1, R6	2	150 Ω $\pm 1\%$ resistors (0805)
R2	1	39.2k Ω $\pm 1\%$ resistor (0805)
R3	1	64.9k Ω $\pm 1\%$ resistor (0805)
R4	1	76.8k Ω $\pm 1\%$ resistor (0805)
R5	1	301k Ω $\pm 1\%$ resistor (0805)
R7, R8, R9	3	100k Ω $\pm 1\%$ resistors (0805)
R10	1	475 Ω $\pm 1\%$ resistor (1206)
S1	1	Momentary tact switch, SPST
U1	1	MAX6791TPLD2+
—	12	Shunts, 2-position (see the <i>Jumper Function Tables</i> section)
—	1	MAX6791 EV kit PC board

**Optional; not installed.

Component Suppliers

SUPPLIER	PHONE	FAX	WEBSITE
International Rectifier	310-322-3331	310-322-3332	www.irf.com
TDK	847-390-4373	847-390-4428	www.component.tdk.com
Vishay	402-563-6866	402-563-6296	www.vishay.com

Note: Indicate you are using the MAX6791–MAX6796 when contacting these manufacturers.



For pricing, delivery, and ordering information, please contact Maxim/Dallas Direct! at 1-888-629-4642, or visit Maxim's website at www.maxim-ic.com.

MAX6791 Evaluation Kit

Quick Start

Required Equipment

- Maxim MAX6791 EV kit
- An adjustable-output power supply capable of supplying at least 12V at 500mA

Procedures

- 1) Make sure that jumpers J1, J2, J4, J5, and J8–J12 are shorted. Make sure jumpers J3, J6, and J7 are in the 2-3 position.
- 2) Connect the power supply to the IN1 and GND connections located at the top of the board.
- 3) Set the power-supply output to 12V and observe LED1 and LED2.

Detailed Description

The MAX6791 EV kit operates from 5V to 72V and provides two regulator outputs, OUT1 and OUT2. OUT1 outputs 5.0V and can be adjusted, and OUT2 is fixed at 5.0V. Each regulator can source up to 150mA, subject to thermal dissipation limits. Each regulator also has an individual enable input, and OUT1 has a HOLD input that allows the regulator to stay on even when its enable signal is deasserted.

Other features include a built-in watchdog timer that provides μ P supervisory functions and a power-fail comparator that senses undervoltage conditions. An on-board p-channel FET provides reverse-battery protection.

Reverse-Battery Protection

To prevent a reversed battery from damaging a circuit, a diode is sometimes inserted in series with the power supply. Since the diode adds an undesirable voltage drop to the circuit, a p-channel FET is often used instead. The MAX6791 EV kit includes a p-channel FET; to use this feature, connect input power to IN2. To bypass the reverse-battery protection, connect input power to IN1.

Voltage Regulator Outputs

OUT1 provides regulated DC at a voltage set by jumper J3, which selects either the fixed output voltage (5.0V) or the output voltage set by resistive divider R2/R3. The default resistor values set the output voltage at 3.3V, but they can easily be changed according to the following equation:

$$V_{\text{OUT}} = V_{\text{SET}} \left(1 + \frac{R3}{R2} \right)$$

where $V_{\text{SET}} = 1.2315\text{V}$ and both R3 and R2 $\leq 200\text{k}\Omega$. When changing the output voltage, ensure R1 is selected correctly to limit the current through LED1.

OUT2 provides a fixed voltage of 5V, which cannot be adjusted.

Enable and Hold Function

Each regulator has an enable connection that can be used to shut off a regulator. OUT1 also has a HOLD input that is connected to button S1. When the button is held down and enable jumper J1 is subsequently removed, the regulator remains on. LED1 also remains on because it indicates the state of OUT1. Likewise, LED2 indicates the state of OUT2.

Reset Timeout

The reset output remains asserted for a certain minimum period that is controlled by J5 and C5. If J5 is shorted, the reset period is the default of 12.5ms. If J5 is open, capacitor C5 sets the timeout period to 26.8ms, but this can easily be changed using the following equation:

$$t_{\text{RP}} = C5 \left(1.218 \times 10^6 \frac{\text{V}}{\text{A}} \right)$$

where t_{RP} is in seconds and C5 is in Farads. Refer to the MAX6791–MAX6796 data sheet for more information on capacitor selection.

Watchdog Timer

The watchdog timer asserts $\overline{\text{RESET}}$ if WDI does not toggle within the watchdog timeout window. The watchdog timeout period defaults to 400ms, unless jumper J4 is removed, in which case the watchdog timeout period is set by C4. The provided capacitor sets the timeout period at 233ms, but this can be changed by setting C4 according to the following equation:

$$t_{\text{WD}} = C4 \left(155 \times 10^6 \frac{\text{V}}{\text{A}} \right)$$

where t_{WD} is in seconds and C4 is in Farads. The watchdog timer also provides a fast watchdog timeout; if WDI toggles faster than the fast watchdog timeout period, the watchdog timer asserts $\overline{\text{RESET}}$. The fast watchdog timeout period is set as a ratio of the watchdog timeout period, and this ratio is selected using jumpers J6 and J7 (see Table 2). To calculate the fast watchdog period, divide the watchdog period by the ratio selected by the two jumpers.

MAX6791 Evaluation Kit

Evaluates: MAX6791-MAX6796

For the watchdog timer to operate, the primary regulator must supply at least 13.8mA. When R10 and LED1 are enabled by J2, they draw enough current to enable the watchdog timer. For OUT1 voltages greater than 5V, resistor R1 will need to be replaced with a larger value to limit the power dissipation in LED1. Remove jumper J2 to disable the watchdog and LED1.

Another way to disable the watchdog timer is to set jumpers J6 and J7 to positions 2-3 and 1-2, respectively.

Power-Fail Indicator

To indicate low input-voltage conditions, a resistive divider connects the input power to the PFI comparator inside the MAX6791. If the voltage drops below 6V, PFO asserts low. Remove jumper J8 to disable the power-fail feature. The threshold voltage may be changed by replacing R4 and R5 using the following equation:

$$V_{PFI} = V_{THRESH} \left(1 + \frac{R5}{R4} \right)$$

where $V_{THRESH} = 1.231V$. Refer to the MAX6791-MAX6796 data sheet for more information.

Jumper Function Tables

Table 1. Jumper Function Table (J1–J5, J8–J12)

JUMPER	POSITION	FUNCTION
J1	Open	OUT1 disabled
	Closed*	OUT1 enabled
J2	Open	OUT1 LED disabled (may also disable the watchdog timer—see text for more information)
	Closed*	OUT1 LED enabled
J3	1-2	OUT1 voltage set by R2 and R3 (3.3V)
	2-3*	OUT1 is 5.0V
J4	Open	Watchdog timeout set by C4 (233ms)
	Closed*	Watchdog timeout is 400ms
J5	Open	Reset timeout set by C5 (26.8ms)
	Closed*	Reset timeout is 12.5ms
J8	Open	PFI disabled
	Closed*	PFI threshold set at 6V
J9	Open	RESET pullup resistor disconnected
	Closed*	RESET pullup resistor connected
J10	Open	PFO pullup resistor disconnected
	Closed*	PFO pullup resistor connected
J11	Open	OUT2 disabled
	Closed*	OUT2 enabled
J12	Open	OUT2 LED disabled
	Closed*	OUT2 LED enabled

*Default configuration.

Table 2. Jumper Function Table (J6, J7)

J7 SHUNT POSITION	J6 SHUNT POSITION	MIN/MAX WATCHDOG RATIO
2-3*	2-3*	8
2-3	1-2	16
1-2	2-3	Watchdog disabled
1-2	1-2	64

*Default configuration.

Evaluates: MAX6791-MAX6796

MAX6791 Evaluation Kit

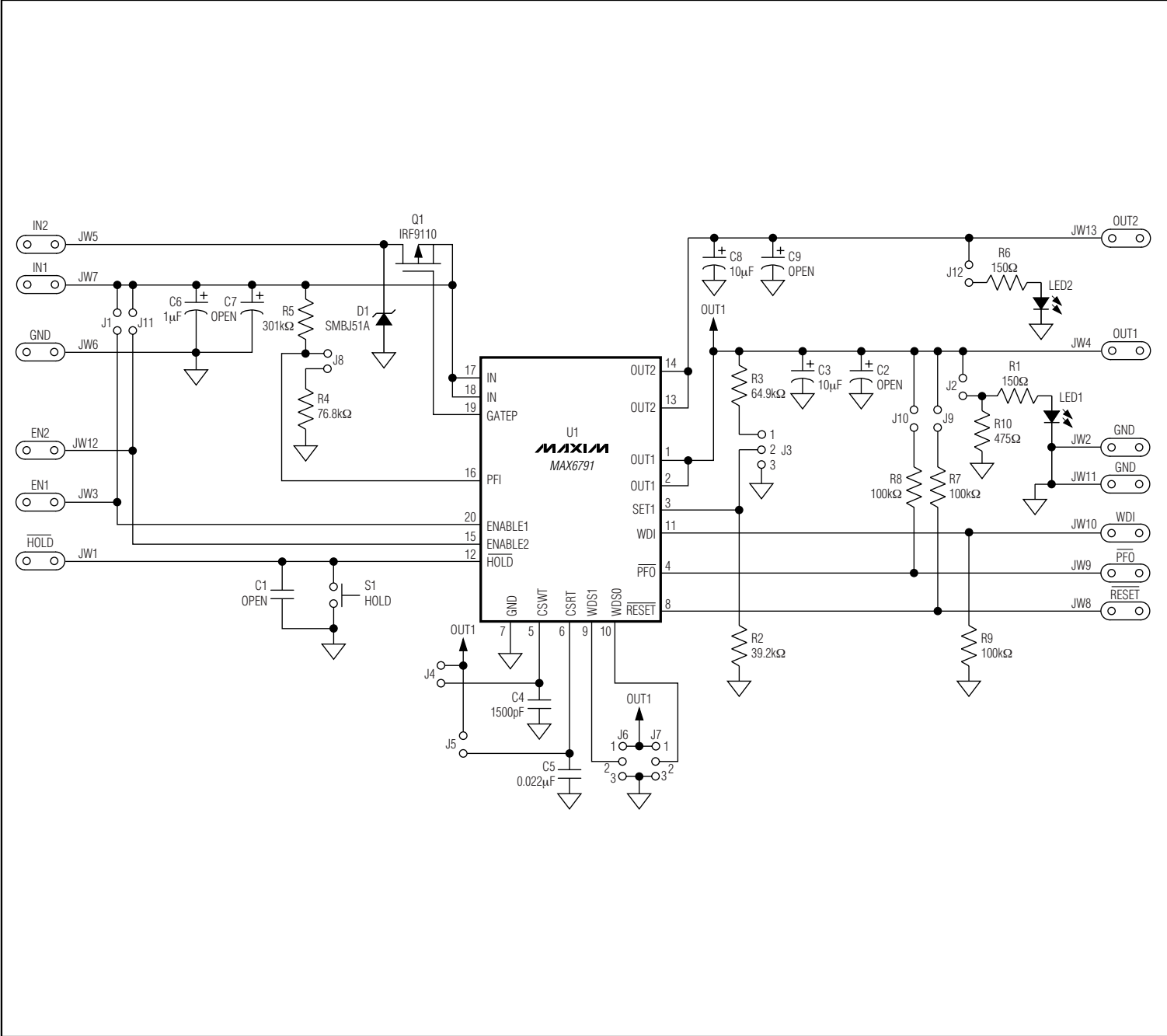

Figure 1. MAX6791 EV Kit Schematic

MAX6791 Evaluation Kit

Evaluates: MAX6791-MAX6796

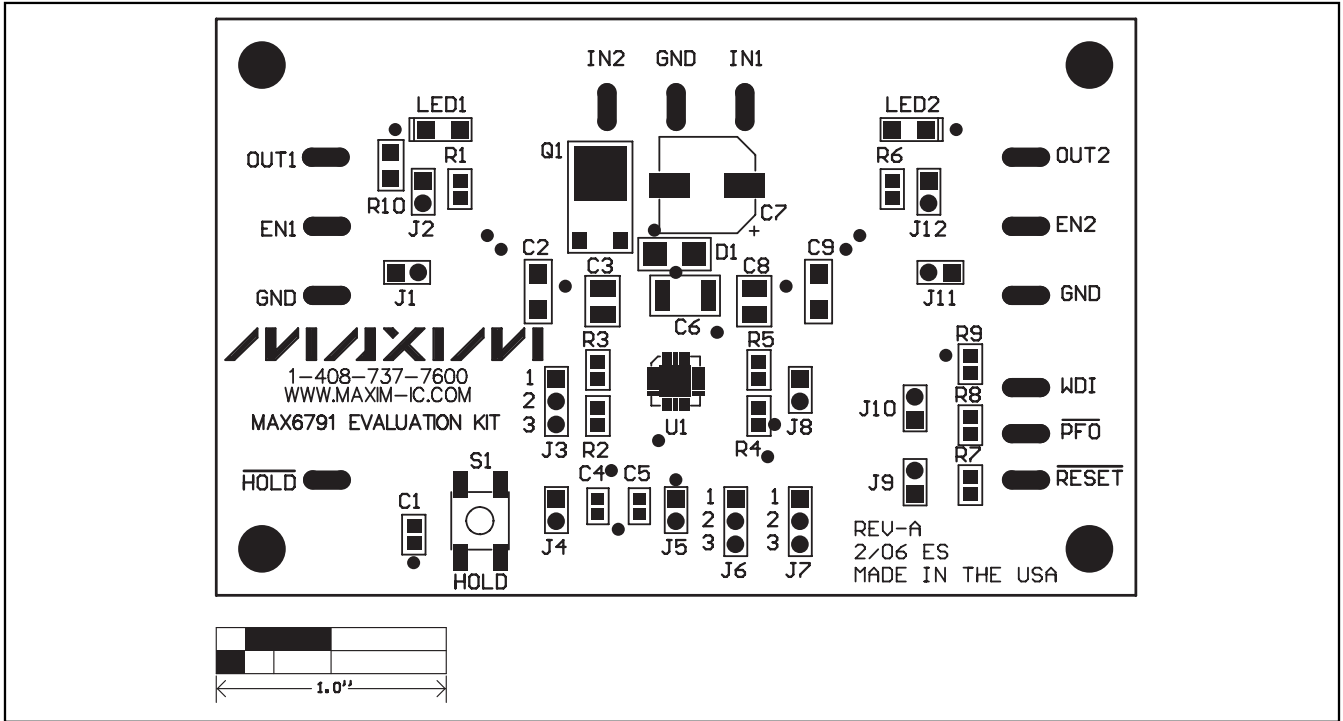

Figure 2. MAX6791 EV Kit Component Placement Guide—Component Side

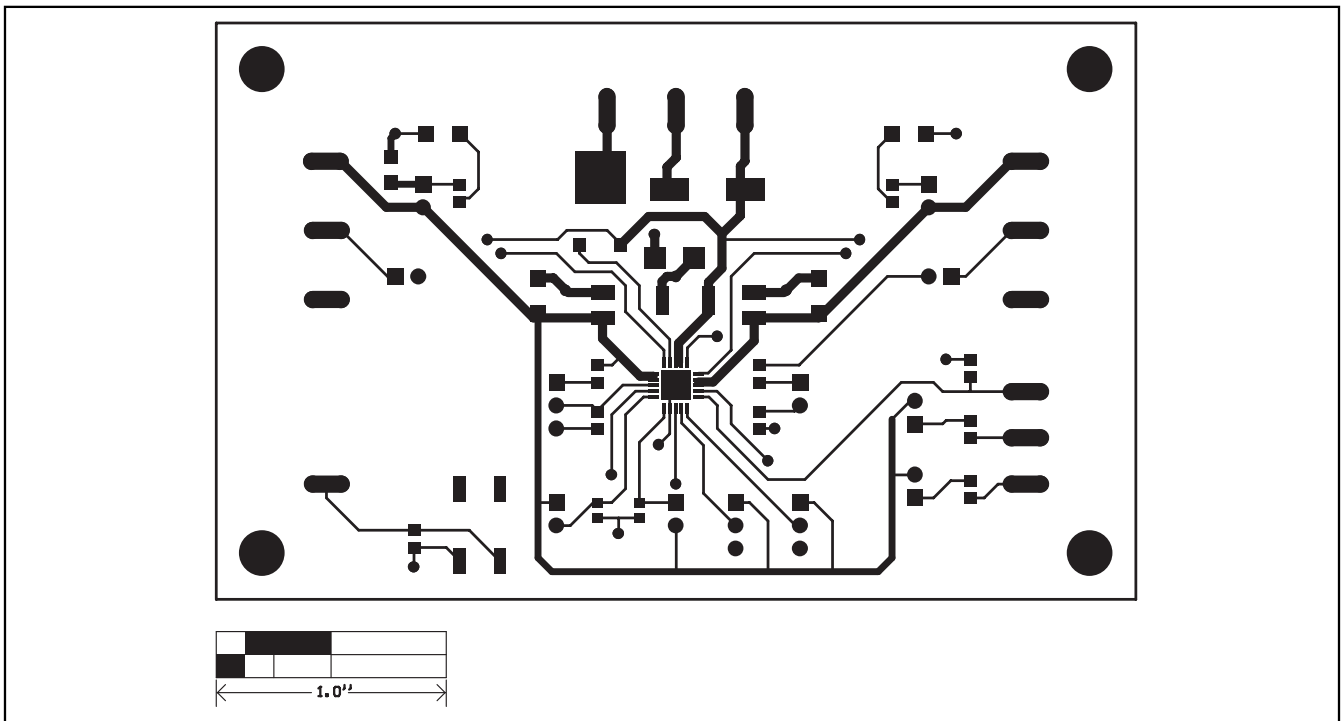

Figure 3. MAX6791 EV Kit PC Board Layout—Component Side

MAX6791 Evaluation Kit

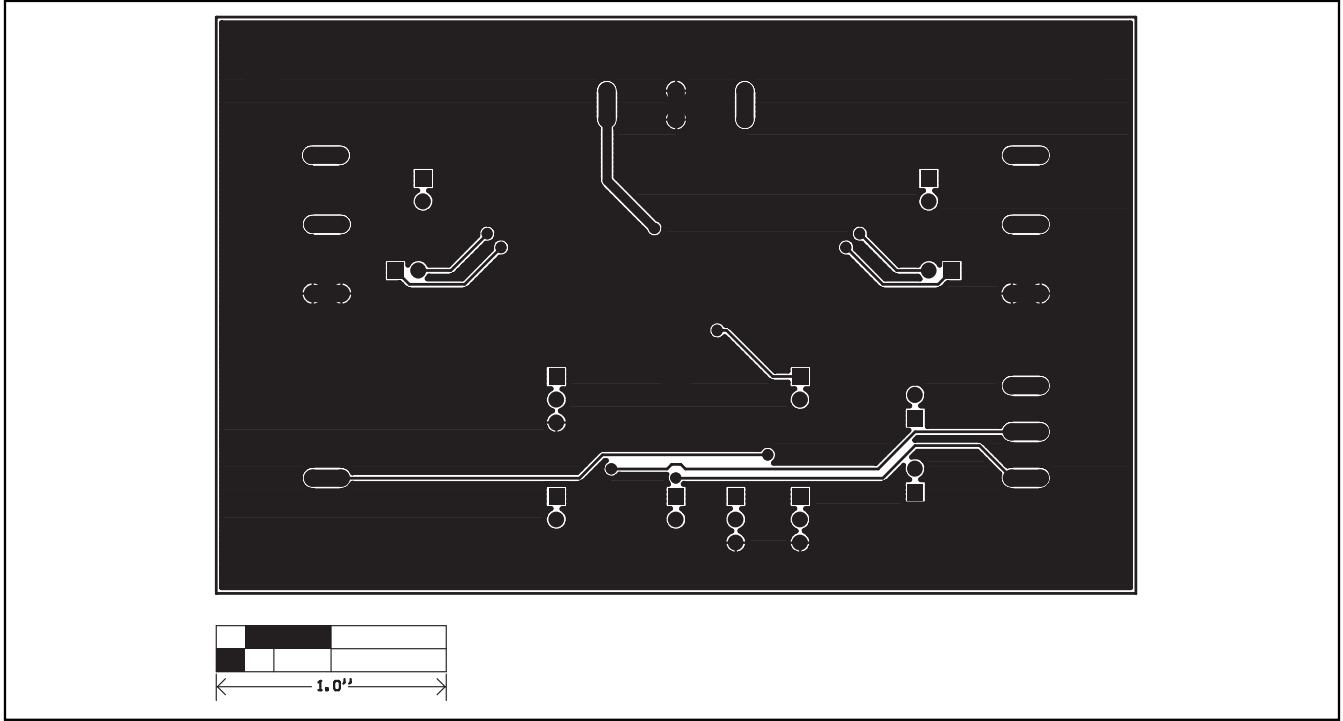

Figure 4. MAX6791 EV Kit PC Board Layout—Solder Side

Maxim cannot assume responsibility for use of any circuitry other than circuitry entirely embodied in a Maxim product. No circuit patent licenses are implied. Maxim reserves the right to change the circuitry and specifications without notice at any time.

6 _____ **Maxim Integrated Products, 120 San Gabriel Drive, Sunnyvale, CA 94086 408-737-7600**