



Chipsmall Limited consists of a professional team with an average of over 10 year of expertise in the distribution of electronic components. Based in Hongkong, we have already established firm and mutual-benefit business relationships with customers from,Europe,America and south Asia,supplying obsolete and hard-to-find components to meet their specific needs.

With the principle of "Quality Parts,Customers Priority,Honest Operation,and Considerate Service",our business mainly focus on the distribution of electronic components. Line cards we deal with include Microchip,ALPS,ROHM,Xilinx,Pulse,ON,Everlight and Freescale. Main products comprise IC,Modules,Potentiometer,IC Socket,Relay,Connector.Our parts cover such applications as commercial,industrial, and automotives areas.

We are looking forward to setting up business relationship with you and hope to provide you with the best service and solution. Let us make a better world for our industry!



Contact us

Tel: +86-755-8981 8866 Fax: +86-755-8427 6832

Email & Skype: info@chipsmall.com Web: www.chipsmall.com

Address: A1208, Overseas Decoration Building, #122 Zhenhua RD., Futian, Shenzhen, China





5-Pin Watchdog Timer Circuit

MAX6814

General Description

The MAX6814 is a low-power watchdog circuit in a tiny 5-pin SC70 package. This device improves system reliability by monitoring the system for software code execution errors. When the watchdog input detects a transitional edge, the internal watchdog timer clears and restarts, then begins counting again. If the watchdog timer exceeds the watchdog timeout period (1.6s typ), the active-low, push-pull watchdog output asserts for the watchdog pulse period (140ms min) to alert the system of the fault.

The MAX6814 consumes only 4 μ A of supply current and is fully specified over the extended temperature range.

Features

- ◆ 4 μ A Operating Current
- ◆ Watchdog Timer with 1.6s Timeout
- ◆ 140ms (min) $\overline{\text{WDO}}$ Pulse Period
- ◆ Push-Pull Active-Low $\overline{\text{WDO}}$
- ◆ Fully Specified Over Extended Temperature Range
- ◆ No External Components

Applications

Computers and Controllers
 Embedded Controllers
 Intelligent Instruments
 Automotive Systems
 Critical μ P Monitoring

Ordering Information

PART	TEMP RANGE	PIN-PACKAGE	TOP MARK
MAX6814XK-T	-40°C to +85°C	5 SC70-5	AEK

Devices are available in both leaded and lead-free packaging. Specify lead-free by replacing "-T" with "+T" when ordering.

Typical Operating Circuit

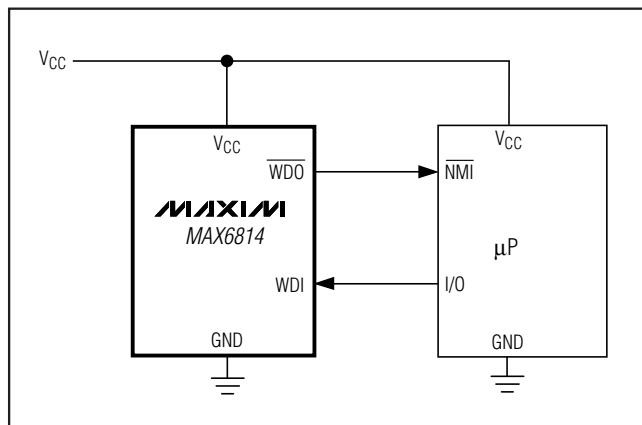

Pin Configuration

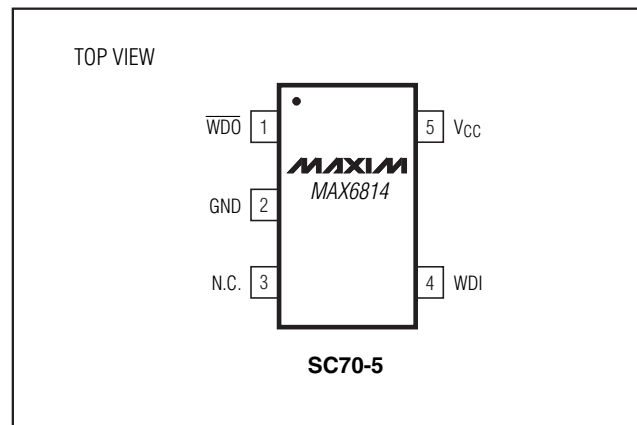

5-Pin Watchdog Timer Circuit

ABSOLUTE MAXIMUM RATINGS

V _{CC}	-0.3V to +6.0V	5-Pin SC70 (derate 3.1mW/°C above +70°C)	247mW
All Other Pins	-0.3V to (V _{CC} + 0.3V)	Operating Temperature Range	-40°C to +85°C
Input Current, WDI	20mA	Storage Temperature Range	-65°C to +150°C
Output Current, WDO	20mA	Junction Temperature	+150°C
Continuous Power Dissipation (T _A = +70°C)		Lead Temperature (soldering, 10s)	+300°C

Stresses beyond those listed under "Absolute Maximum Ratings" may cause permanent damage to the device. These are stress ratings only, and functional operation of the device at these or any other conditions beyond those indicated in the operational sections of the specifications is not implied. Exposure to absolute maximum rating conditions for extended periods may affect device reliability.

ELECTRICAL CHARACTERISTICS

(V_{CC} = +2.25V to +5.5V, T_A = T_{MIN} to T_{MAX}, T_A = -40°C to +85°C, unless otherwise noted. Typical values are at T_A = +25°C.)
(Note 1)

PARAMETER	SYMBOL	CONDITIONS	MIN	TYP	MAX	UNITS
Operating Voltage Range	V _{CC}	T _A = 0°C to +70°C	2.25		5.5	V
Supply Current	I _{SUPPLY}	WDI unconnected	V _{CC} = 5.5V	10	24	μA
			V _{CC} = 2.5V	4	12	
Undervoltage Lockout Threshold	UVLO	(Note 2)		2.19		V
Watchdog Pulse Period	t _{PP}	(Note 3)	140	200	280	ms
WDO Output Voltage	V _{OH}	I _{SOURCE} = 30μA, V _{CC} = 2.3V	0.8 × V _{CC}			V
	V _{OL}	I _{SINK} = 1.2mA, V _{CC} = 2.1V			0.3	
WDO Output Short-Circuit Current	I _{SOURCE}	V _{CC} = 3.6V (Note 4)			400	μA
Watchdog Timeout Period	t _{WD}		1.12	1.60	2.40	s
WDI Pulse Width	t _{WDI}	V _{IL} = 0.4V, V _{IH} = 0.8 × V _{CC}	50			ns
WDI Input Voltage (Note 5)	V _{IL}		0.3 × V _{CC}			V
	V _{IH}		0.7 × V _{CC}			
WDI Input Current (Note 6)		WDI = V _{CC} , time average		120	160	μA
		WDI = 0, time average	-20	-15		

Note 1: Overtemperature limits are guaranteed by design, production testing performed at +25°C only.

Note 2: WDO is low when V_{CC} falls below the undervoltage threshold. When V_{CC} rises above the undervoltage threshold, WDO goes high after the watchdog pulse period.

Note 3: Watchdog pulse period occurs when the watchdog times out or after V_{CC} rises above the undervoltage threshold.

Note 4: The WDO short-circuit current is the maximum pullup current when WDO is driven low.

Note 5: WDI is internally serviced within the watchdog period if WDI is left unconnected.

Note 6: The WDI input current is specified as the average input current when the WDI input is driven high or low. The WDI input is designed to drive a three-stated output device with a 10μA maximum leakage current and a maximum capacitive load of 200pF. This output device must be able to source and sink at least 200μA when active.

5-Pin Watchdog Timer Circuit

Typical Operating Characteristics

($V_{CC} = +5V$, $T_A = +25^{\circ}C$, unless otherwise noted.)

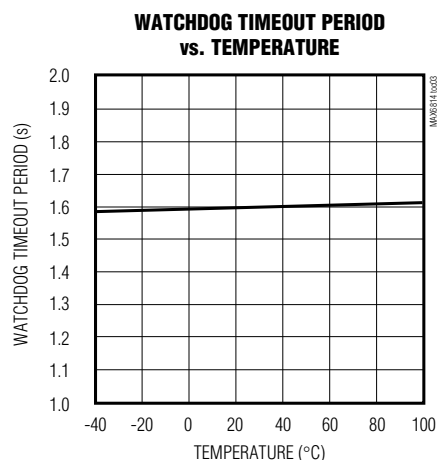
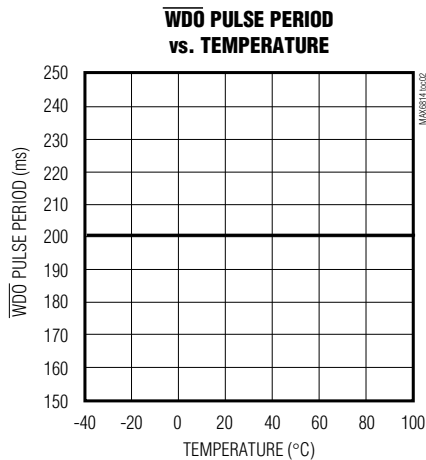
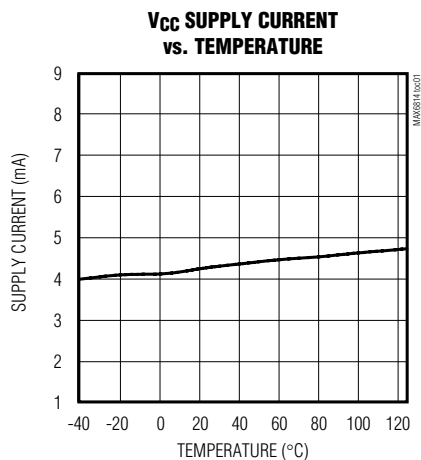

Pin Description

PIN	NAME	FUNCTION
1	\overline{WDO}	Active-Low Watchdog Output. Pulses low for 140ms (min) when the watchdog timer exceeds the watchdog timeout period. \overline{WDO} is low when V_{CC} is below the UVLO threshold and remains low for 140ms (min) after V_{CC} exceeds the UVLO threshold.
2	GND	Ground
3	N.C.	No Connection. Leave unconnected or connect to V_{CC} .
4	WDI	Watchdog Input. If WDI remains either high or low for longer than the watchdog timeout period, the internal watchdog timer runs out and a watchdog pulse period is triggered. The internal watchdog timer clears whenever a watchdog pulse period is asserted, or whenever WDI sees a rising or falling edge. If WDI is left unconnected or is connected to a three-stated buffer output, the watchdog is disabled.
5	V_{CC}	Supply Voltage

5-Pin Watchdog Timer Circuit

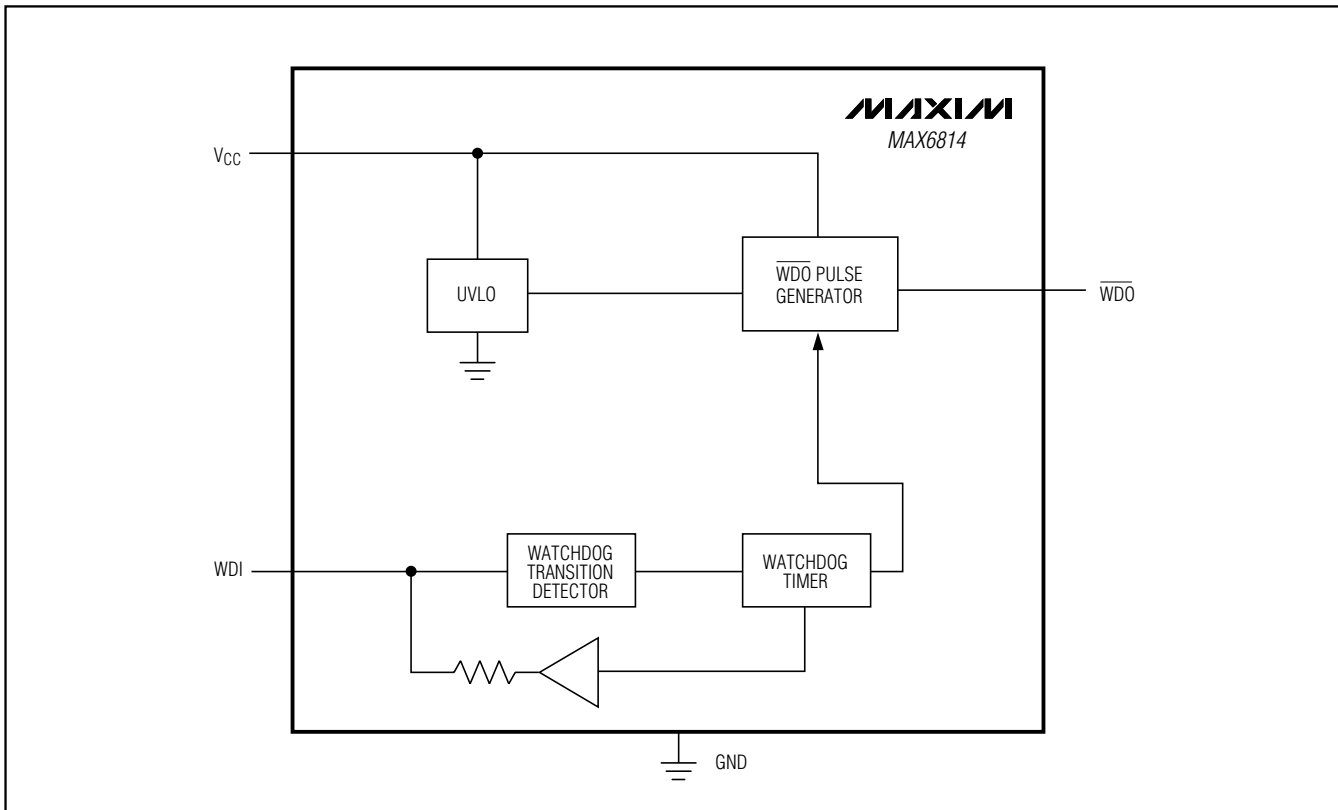

Figure 1. Functional Diagram

Detailed Description

Watchdog Input

In the MAX6814, the watchdog circuit monitors the μ P's activity. If the μ P does not toggle the watchdog input (WDI) within t_{WD} (1.6s), \overline{WDO} asserts. The internal 1.6s timer is cleared by either a \overline{WDO} pulse or by toggling WDI, which detects pulses as short as 50ns. While \overline{WDO} is asserted, the timer remains cleared and does not count. As soon as \overline{WDO} is released, the timer starts counting (Figure 3).

Disable the watchdog function by leaving WDI unconnected or by three-stating the driver connected to WDI. The watchdog input is internally driven low during the first 7/8 of the watchdog timeout period and high for the last 1/8 of the watchdog timeout period. When WDI is left unconnected, this internal driver clears the 1.6s timer every 1.4s. When WDI is three-stated or unconnected, the maximum allowable leakage current is 10 μ A and the maximum allowable load capacitance is 200pF.

Applications Information

Watchdog Input Current

The MAX6814 WDI inputs are internally driven through a buffer and series resistor from the watchdog counter (Figure 1). When WDI is left unconnected, the watchdog timer is serviced within the watchdog timeout period by a low-high-low pulse from the counter chain. For minimum watchdog input current (minimum overall power consumption), leave WDI low for the majority of the watchdog timeout period, pulsing it low-high-low once within the first 7/8 of the watchdog timeout period to clear the watchdog timer. If WDI is externally driven high for the majority of the timeout period, up to 160 μ A can flow into WDI.

5-Pin Watchdog Timer Circuit

Watchdog Software Considerations

One way to help the watchdog timer monitor software execution more closely is to set and clear the watchdog input at different points in the program, rather than pulsing the watchdog input high-low-high or low-high-low. This technique avoids a stuck loop, in which the watchdog timer would continue to be cleared inside the loop, keeping the watchdog from timing out.

Figure 4 shows an example of a flow diagram where the I/O driving the watchdog input is set high at the beginning of the program, set low at the beginning of

every subroutine or loop, then set high again when the program returns to the beginning. If the program should hang in any subroutine, the problem would quickly be corrected, since the I/O is continually set low and the watchdog timer is allowed to time out, causing an interrupt to be issued. This scheme results in higher time average WDI input current than does leaving WDI low for the majority of the timeout period and periodically pulsing it low-high-low (see the *Watchdog Input Current* section).

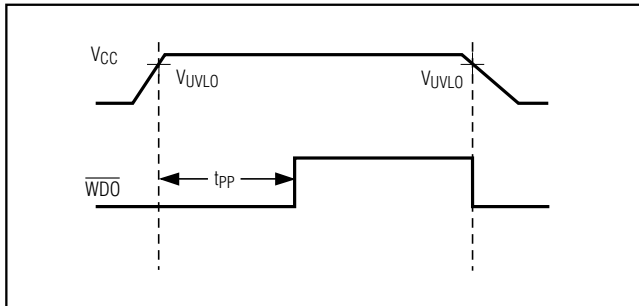

Figure 2. Power-Up Timing Diagram

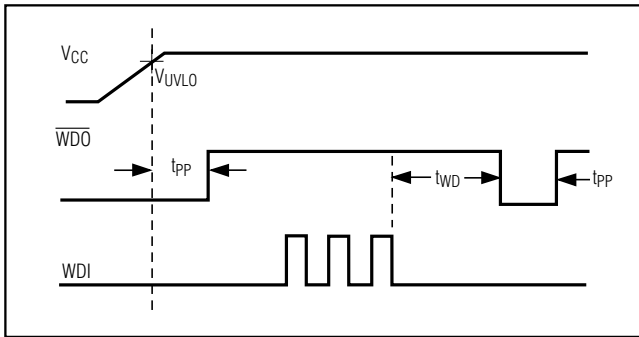

Figure 3. Watchdog Timing Relationship

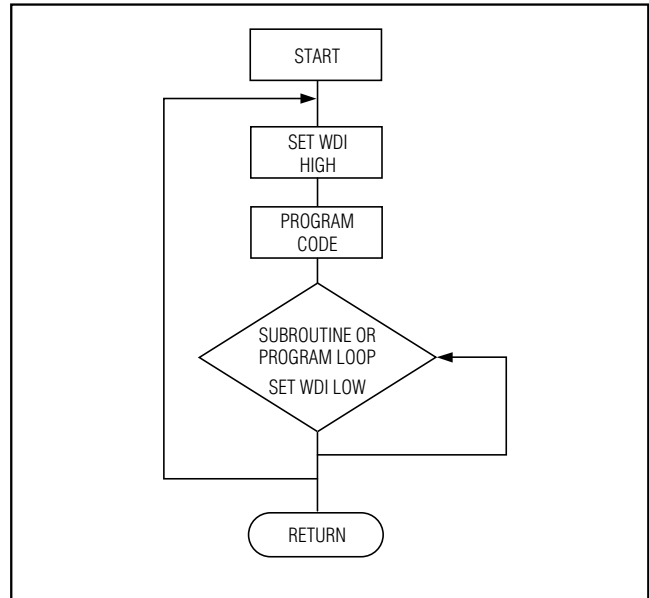

Figure 4. Watchdog Flow Diagram

Chip Information

TRANSISTOR COUNT: 607

PROCESS: BiCMOS

5-Pin Watchdog Timer Circuit

Package Information

(The package drawing(s) in this data sheet may not reflect the most current specifications. For the latest package outline information go to www.maxim-ic.com/packages.)

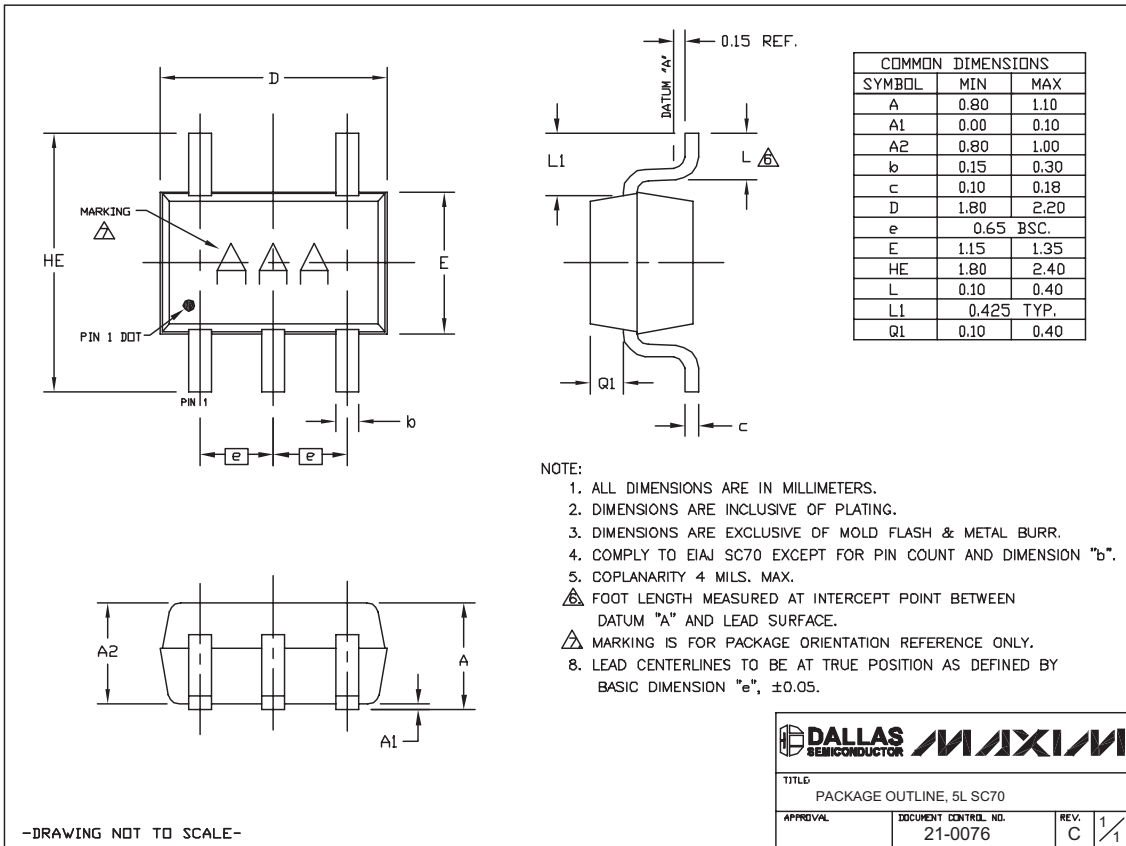

SC70, 5LEPS

DALLAS SEMICONDUCTOR **MAXIM**

TITLE: PACKAGE OUTLINE, 5L SC70

APPROVAL	DOCUMENT CONTROL NO. 21-0076	REV. C	1/1
----------	---------------------------------	--------	-----

Maxim cannot assume responsibility for use of any circuitry other than circuitry entirely embodied in a Maxim product. No circuit patent licenses are implied. Maxim reserves the right to change the circuitry and specifications without notice at any time.

6 **Maxim Integrated Products, 120 San Gabriel Drive, Sunnyvale, CA 94086 (408) 737-7600**