



Chipsmall Limited consists of a professional team with an average of over 10 year of expertise in the distribution of electronic components. Based in Hongkong, we have already established firm and mutual-benefit business relationships with customers from,Europe,America and south Asia,supplying obsolete and hard-to-find components to meet their specific needs.

With the principle of “Quality Parts,Customers Priority,Honest Operation,and Considerate Service”,our business mainly focus on the distribution of electronic components. Line cards we deal with include Microchip,ALPS,ROHM,Xilinx,Pulse,ON,Everlight and Freescale. Main products comprise IC,Modules,Potentiometer,IC Socket,Relay,Connector.Our parts cover such applications as commercial,industrial, and automotives areas.

We are looking forward to setting up business relationship with you and hope to provide you with the best service and solution. Let us make a better world for our industry!



Contact us

Tel: +86-755-8981 8866 Fax: +86-755-8427 6832

Email & Skype: info@chipsmall.com Web: www.chipsmall.com

Address: A1208, Overseas Decoration Building, #122 Zhenhua RD., Futian, Shenzhen, China



MAX710/MAX711

3.3V/5V or Adjustable, Step-Up/Down DC-DC Converters

General Description

The MAX710/MAX711 integrate a step-up DC-DC converter with a linear regulator to provide step-up/down voltage conversion. They are optimized for battery applications where the input varies above and below the regulated output voltage. They have an input range from +1.8V to +11V. Typical efficiency when boosting battery inputs is 85%.

The MAX710/MAX711 can be configured for minimum noise or optimum efficiency. Shutdown control turns off the part completely, disconnecting the input from the output ($I_{SHDN} = 0.2\mu\text{A}$). Standby control turns off only the step-up converter and leaves the low-power linear regulator active ($I_Q = 7\mu\text{A}$).

The MAX710 has a preset 3.3V or 5V output voltage. The MAX711 has an adjustable output that can be set from +2.7V to +5.5V with two resistors. Both devices come in 16-pin narrow SO packages.

Applications

Single-Cell, Lithium-Powered Portable Devices
 Digital Cameras
 2- to 4-Cell AA Alkaline Hand-Held Equipment
 3.3V and Other Low-Voltage Systems
 2-, 3-, and 4-Cell Battery-Powered Equipment
 Battery-Powered Devices with AC Input Adapters

Typical Operating Circuit

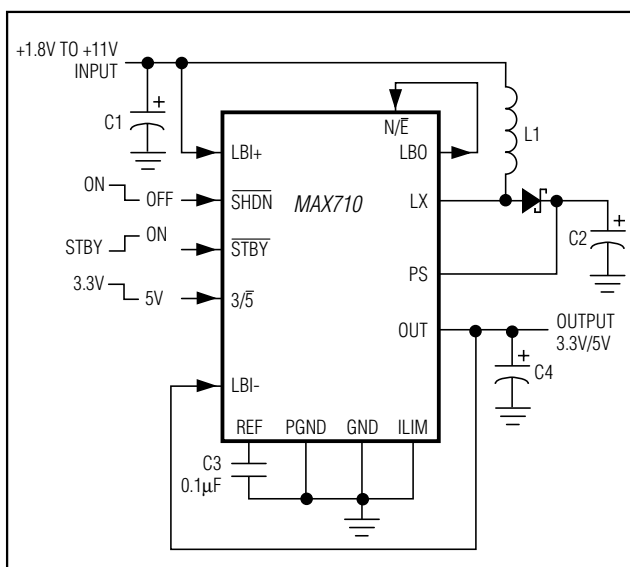

Features

- ◆ Step-Up/Down Voltage Conversion
- ◆ +1.8V to +11V Input Range
- ◆ Output:
 - 5V/250mA at $V_{IN} = 1.8\text{V}$
 - 5V/500mA at $V_{IN} = 3.6\text{V}$
- ◆ No External FETs Required
- ◆ Load Disconnected from Input in Shutdown
- ◆ Battery Drain:
 - 200µA No-Load ($V_{IN} = 4\text{V}$)
 - 7µA in Standby
 - 0.2µA when Off
- ◆ Low-Noise and High-Efficiency Modes

Ordering Information

PART	TEMP. RANGE	PIN-PACKAGE
MAX710C/D	0°C to +70°C	Dice
MAX710ESE	-40°C to +85°C	16 Narrow SO
MAX711C/D	0°C to +70°C	Dice
MAX711ESE	-40°C to +85°C	16 Narrow SO

Pin Configuration

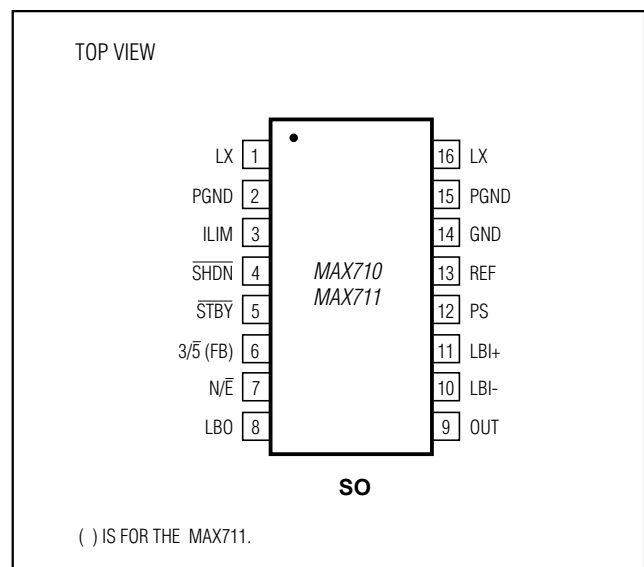

MAX710/MAX711

3.3V/5V or Adjustable, Step-Up/Down DC-DC Converters

ABSOLUTE MAXIMUM RATINGS

PS, LX, OUT to GND.....-0.3V to +11.5V
 ILIM, SHDN, STBY, FB, 3/5, N/E, LBO,
 LBI-, LBI+, REF to GND-0.3V to (VPS + 0.3V)
 PGND to GND-0.3V to +0.3V
 REF Short Circuit to GNDContinuous
 IOUT.....700mA

Continuous Power Dissipation (TA = +70°C)
 SO (derate 8.70mW/°C above +70°C).....696mW
 Operating Temperature Range-40°C to +85°C
 Storage Temperature Range-65°C to +160°C
 Junction Temperature+150°C
 Lead Temperature (soldering, 10sec).....+300°C

Stresses beyond those listed under "Absolute Maximum Ratings" may cause permanent damage to the device. These are stress ratings only, and functional operation of the device at these or any other conditions beyond those indicated in the operational sections of the specifications is not implied. Exposure to absolute maximum rating conditions for extended periods may affect device reliability.

ELECTRICAL CHARACTERISTICS

(VPS = 5.6V, STBY = PS, CREF = 0.1µF, COUT = 4.7µF, TA = -40°C to +85°C, unless otherwise noted. Typical values are at TA = +25°C.) (Note 1)

PARAMETER	CONDITIONS		MIN	TYP	MAX	UNITS
Input Voltage	N/E = PS		1.8		11.0	V
	N/E = GND (Note 2)		1.8		7.0	
Full Load Start-Up Voltage				0.9		V
Output Voltage (MAX710)	3/5 = low, IOUT = 0 to 250mA	TA = 0°C to +85°C	4.8	5.0	5.2	V
		TA = -40°C to +85°C	4.6	5.0	5.3	
	3/5 = high, IOUT = 0 to 250mA, VPS = 4.7V	TA = 0°C to +85°C	3.17	3.3	3.43	
		TA = -40°C to +85°C	3.05	3.3	3.55	
Output Voltage-Adjustment Range	MAX711		FB		5.5	V
Output Voltage Load Regulation	0 < IOUT < 250mA, STBY = PS			0.5		%
Output Voltage Line Regulation	STBY = PS, 1.8V to 5V			0.3		%/V
Quiescent Current	VSTBY = VSHDN = logic high, current measured into PS pin; ILOAD = 0			100	140	µA
Standby Quiescent Current	VSTBY = 0V			7	16	µA
Shutdown Quiescent Current	VSHDN = 0V			0.1	5	µA
Reference Voltage	TA = 0°C to +85°C, IREF = 0		1.24	1.28	1.31	V
	TA = -40°C to +85°C, IREF = 0		1.23	1.28	1.32	
Standby Output Current	VSTBY = 0V, linear regulator				10	mA
FB Voltage	MAX711, OUT = FB	TA = 0°C to +85°C	1.20	1.25	1.29	mV
		TA = -40°C to +85°C	1.18	1.25	1.31	
Load Regulation	MAX711, OUT = FB	0mA ≤ ILOAD ≤ 250mA		0.1	1	%
FB Input Current	FB = 1.25V			1	50	nA
LX On-Resistance	VPS = 5.6V			0.2	0.6	Ω
	MAX710, VPS = 3.7V			0.3	0.9	
	MAX711, VPS = 2.7V			0.6	1.2	
LX Leakage Current	VLX = 5.6V			0.1	1	µA
LX Current Limit	ILIM = PS		0.5	0.8	1.3	A
	ILIM = GND		1.1	1.5	1.95	

MAX710/MAX711

3.3V/5V or Adjustable, Step-Up/Down DC-DC Converters

ELECTRICAL CHARACTERISTICS (continued)

(V_{PS} = 5.6V, $\overline{\text{STBY}}$ = PS, C_{REF} = 0.1μF, C_{OUT} = 4.7μF, T_A = -40°C to +85°C, unless otherwise noted. Typical values are at T_A = +25°C.) (Note 1)

PARAMETER	CONDITIONS	MIN	TYP	MAX	UNITS
Output PFET Resistance	V _{OUT} = 5.0V		0.7	1.3	Ω
	MAX710, V _{OUT} = 3.0V		1.3	2.4	
	MAX711, V _{OUT} = 2.7V		1.6	3.0	
Output PFET Leakage	V _{PS} = 3V, V _{OUT} = 0V		0.4	3	μA
Thermal Shutdown	$\overline{\text{STBY}}$ = PS		150		°C
Thermal Shutdown Hysteresis	$\overline{\text{STBY}}$ = PS		20		°C
LOGIC					
Input Low Voltage	$\overline{\text{STBY}}$, $\overline{\text{SHDN}}$, N/ $\overline{\text{E}}$, 3/ $\overline{\text{S}}$, ILIM			0.4	V
Input High Voltage	$\overline{\text{STBY}}$, $\overline{\text{SHDN}}$, N/ $\overline{\text{E}}$, 3/ $\overline{\text{S}}$, ILIM	1.6			V
Input Bias Current	$\overline{\text{STBY}}$, $\overline{\text{SHDN}}$, N/ $\overline{\text{E}}$, 3/ $\overline{\text{S}}$, ILIM		1	50	nA
LBI/LBO COMPARATOR					
Input Range LBI-, LBI+	(Note 3)	1.2		10	V
Input Bias Current LBI-, LBI+	V _{LBI-} , V _{LBI+} = 1.25V		1	50	nA
Hysteresis		6	40	100	mV
LBI/LBO Offset Voltage	V _{LBI-} = 1.25V	-25		+25	mV
LBO Output Voltage	I _{LBO} = 2mA, V _{LBI-} = 1.25V, V _{LBI+} = 1V			0.4	V
	I _{LBO} = -300μA, V _{LBI-} = 1.25V, V _{LBI+} = 2V	V _{PS} - 0.2V			

Note 1: Specifications at -40°C are guaranteed by design, not production tested.

Note 2: Guaranteed by design (see Table 1).

Note 3: The LBO comparator provides the correct result as long as one input is within the specified input range.

MAX710/MAX711

3.3V/5V or Adjustable, Step-Up/Down DC-DC Converters

Typical Operating Characteristics

($T_A = +25^\circ\text{C}$, unless otherwise noted.)

**EFFICIENCY vs. OUTPUT CURRENT—
HIGH-EFFICIENCY MODE
($V_{OUT} = 5V$)**

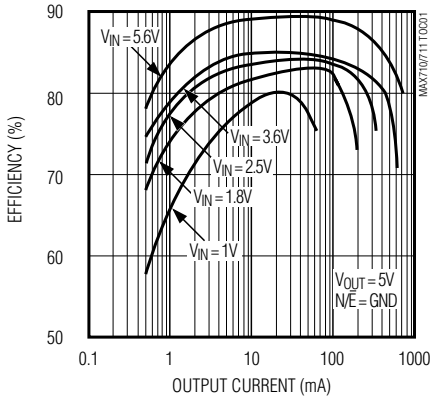

**EFFICIENCY vs. OUTPUT CURRENT—
HIGH-EFFICIENCY MODE
($V_{OUT} = 3.3V$)**

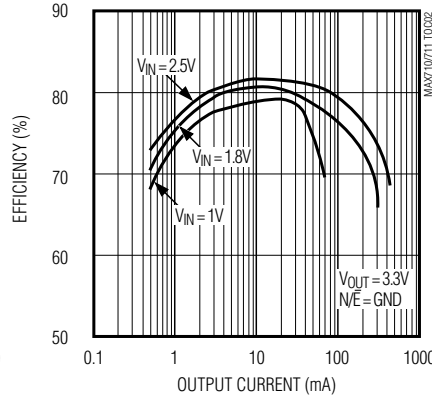

**MINIMUM START-UP INPUT VOLTAGE
vs. LOAD CURRENT**

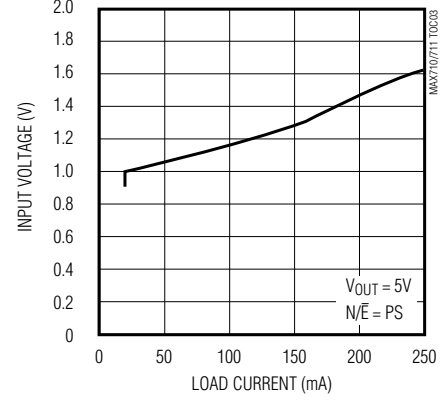

**EFFICIENCY vs. LOAD CURRENT—
HIGH-EFFICIENCY AND LOW-NOISE MODES
($V_{OUT} = 5V$)**

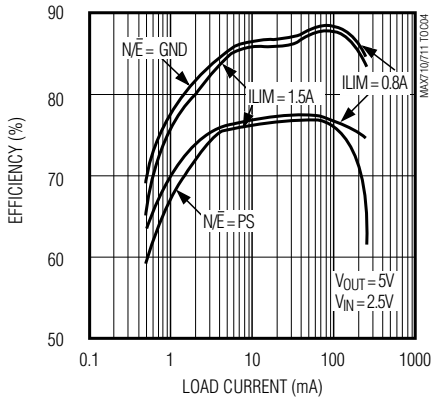

**EFFICIENCY vs. LOAD CURRENT—
HIGH-EFFICIENCY AND LOW-NOISE MODES
($V_{OUT} = 3.3V$)**

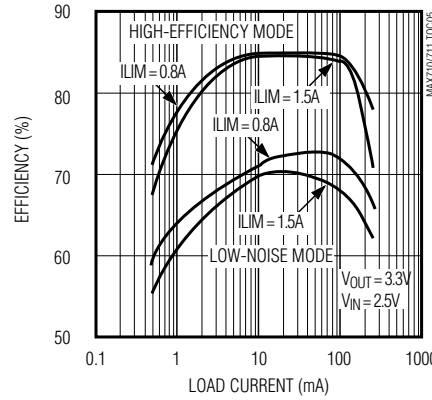

**NO-LOAD BATTERY CURRENT
vs. INPUT VOLTAGE**

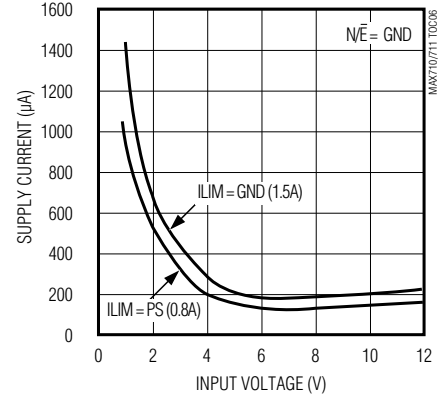

**MAXIMUM OUTPUT CURRENT
vs. INPUT VOLTAGE**

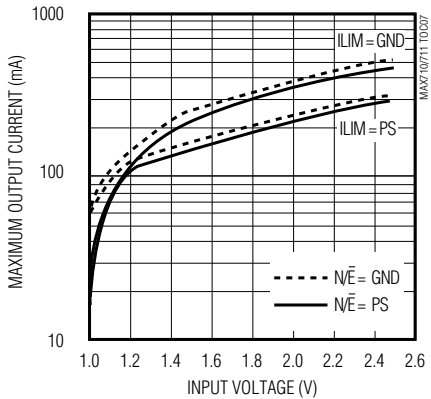

**LINEAR-REGULATOR POWER-SUPPLY
REJECTION RATIO vs. FREQUENCY**

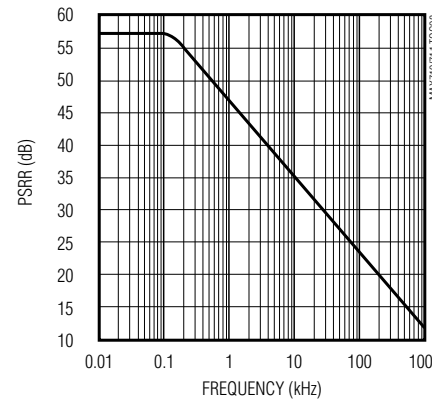

**SHUTDOWN CURRENT
vs. INPUT VOLTAGE**

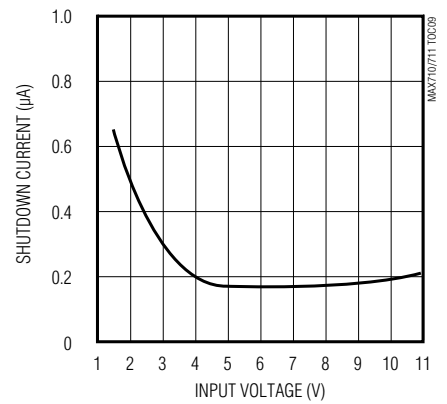

MAX710/MAX711

3.3V/5V or Adjustable, Step-Up/Down DC-DC Converters

Typical Operating Characteristics (continued)

($T_A = +25^\circ\text{C}$, unless otherwise noted.)

LINE-TRANSIENT RESPONSE

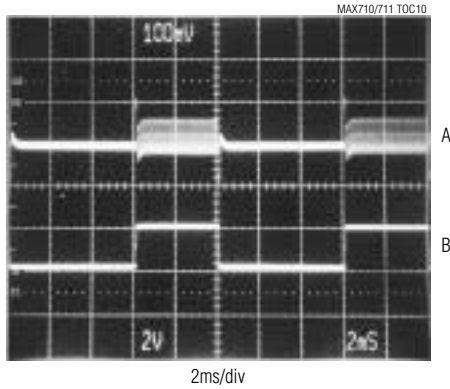

A: $V_{OUT} = 3.3\text{V}$ (100mV/div, AC COUPLED), $N/\bar{E} = \text{GND}$
 B: $V_{IN} = 2\text{V TO } 4\text{V}$, $I_{OUT} = 100\text{mA}$

LOAD-TRANSIENT RESPONSE

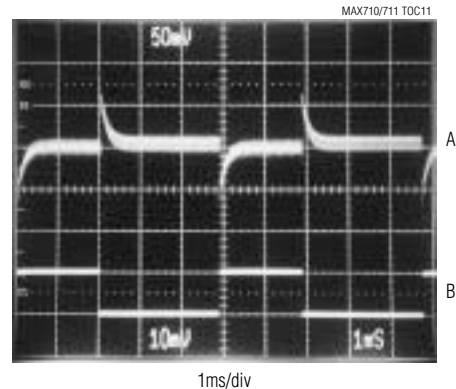

A: $V_{OUT} = 3.3\text{V}$ (50mV/div, AC COUPLED), $N/\bar{E} = \text{PS}$
 B: $I_{OUT} = 10\text{mA TO } 100\text{mA}$

OUTPUT RIPPLE (HIGH-EFFICIENCY MODE)

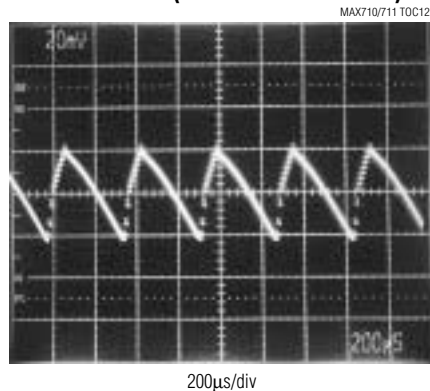

$V_{IN} = 2.5\text{V}$, $I_{OUT} = 20\text{mA}$, $N/\bar{E} = \text{GND}$
 $V_{OUT} = 5\text{V}$ (20mV/div, AC COUPLED), $I_{OUT} = 20\text{mA}$

OUTPUT RIPPLE (LOW-NOISE MODE)

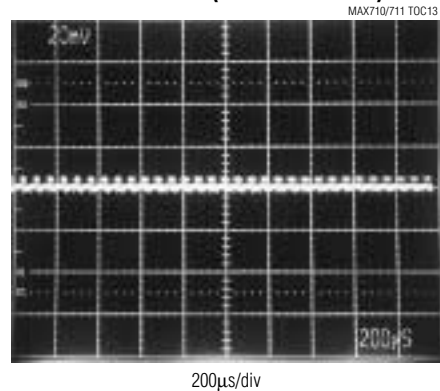

$V_{IN} = 2.5\text{V}$, $I_{OUT} = 20\text{mA}$, $N/\bar{E} = \text{PS}$
 $V_{OUT} = 5\text{V}$ (20mV/div, AC COUPLED), $I_{OUT} = 20\text{mA}$

START-UP DELAY

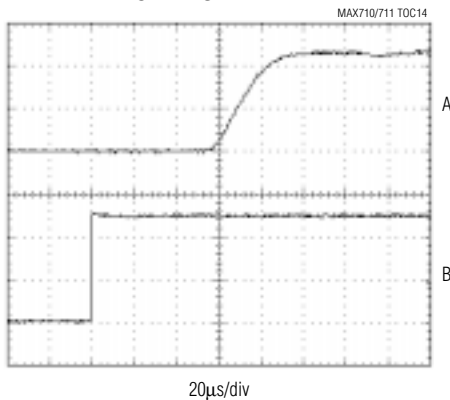

A: V_{OUT} (2V/div), $I_{OUT} = 100\text{mA}$
 B: V_{SHDN} (2V/div)

TURN-OFF DELAY



A: V_{OUT} (2V/div), $I_{OUT} = 100\text{mA}$
 B: V_{SHDN} (2V/div)

MAX710/MAX711

3.3V/5V or Adjustable, Step-Up/Down DC-DC Converters

Pin Description

PIN		NAME	FUNCTION
MAX710	MAX711		
1	1	LX	Drain Connection for internal N-channel power MOSFET
2	2	PGND	Power Ground
3	3	ILIM	Inductor Current-Limit-Select Input. Connect to GND for 1.5A limit and to PS for 0.8A limit.
4	4	$\overline{\text{SHDN}}$	Shutdown Input. When low, the entire circuit is off and OUT is actively pulled to GND.
5	5	$\overline{\text{STBY}}$	Standby Input. Connect to GND to disable boost circuit. Connect to PS for normal operation.
6	—	$3\overline{\text{V}}$	Selects the output voltage. Connect to GND for 5V output and to OUT for 3.3V output.
—	6	FB	Feedback Input
7	7	$\text{N}/\overline{\text{E}}$	Selects low-noise or high-efficiency mode. Connect to GND for high efficiency and to PS for lowest noise. See <i>Operating Configurations</i> section.
8	8	LBO	Low-Battery Comparator Output
9	9	OUT	Linear-Regulator Output. Bypass with a 4.7 μF capacitor to GND.
10	10	LBI-	Negative Input to Low-Battery Comparator
11	11	LBI+	Positive Input to Low-Battery Comparator
12	12	PS	Source of internal PFET regulator. The IC is powered from PS.
13	13	REF	1.28V Reference Voltage Output. Bypass with a 0.1 μF capacitor to GND.
14	14	GND	Analog Ground. Must be low impedance. Solder directly to ground plane.
15	15	PGND	Power Ground
16	16	LX	Drain Connection for internal N-channel power MOSFET

Detailed Description

The MAX710/MAX711 integrate a step-up DC-DC converter with a linear regulator to provide step-up/down voltage conversion. The step-up switch-mode regulator contains an N-channel power MOSFET switch. It also shares a precision voltage reference with a linear regulator that contains a P-channel MOSFET pass element (Figure 1).

Step-Up Operation

A pulse-frequency-modulation (PFM) control scheme with a constant 1 μs off-time and variable on-time controls the N-channel MOSFET switch. The N-channel switch turns off when the part reaches the peak current limit or the 4 μs maximum on-time. The ripple frequency is a function of load current and input voltage.

Step-Down Operation

The low-dropout linear regulator consists of a reference, an error amplifier, and a P-channel MOSFET. The reference is connected to the error amplifier's inverting

input. The error amplifier compares this reference with the selected feedback voltage and amplifies the difference. The difference is conditioned and applied to the P-channel pass transistor's gate.

Operating Configurations

The MAX710/MAX711 have several operating configurations to minimize noise and optimize efficiency for different input voltage ranges. These configurations are accomplished via the $\text{N}/\overline{\text{E}}$ input, which controls operation of the on-chip linear regulator.

With $\text{N}/\overline{\text{E}}$ low, the linear regulator behaves as a 0.7 Ω (at 5V output) PFET switch when the IC is boosting, and as a conventional linear regulator when $V_{\text{IN}} > V_{\text{OUT}}$. This provides optimum boost efficiency, but the PFET does little to reject boost-converter output ripple. With $\text{N}/\overline{\text{E}}$ high, boost ripple rejection is optimized by maintaining headroom (V_{FV} , typically 0.5V at 5V output) across the linear regulator. Boost mode efficiency is then about 10% lower than with $\text{N}/\overline{\text{E}}$ high.

MAX710/MAX711

3.3V/5V or Adjustable, Step-Up/Down DC-DC Converters

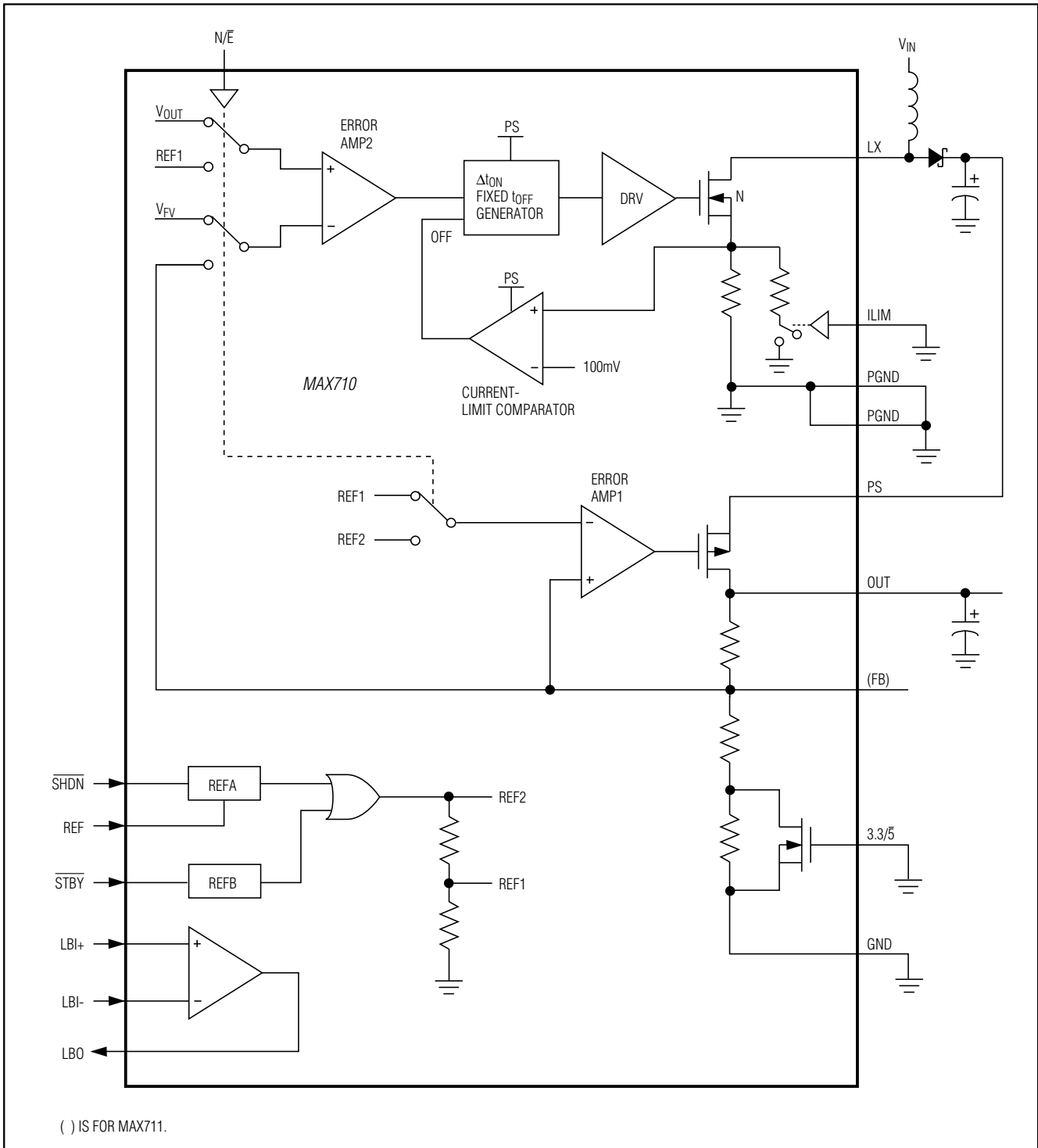

Figure 1. Functional Diagram

MAX710/MAX711

3.3V/5V or Adjustable, Step-Up/Down DC-DC Converters

In high-efficiency mode (N/\bar{E} = low), the maximum input voltage is limited to 7V. This voltage limitation is easily overcome, however, by configuring the LBO output to change modes based on input voltage, allowing an 11V maximum input with high-efficiency configurations. Four operating configurations are described in Table 1 and in the following subsections.

Table 1. Operating Configurations

NO.	DESCRIPTION	INPUT VOLTAGE	CONNECTIONS
1	High efficiency, 7V max V_{IN}	Up to 7V	N/\bar{E} = GND
2	High efficiency, $V_{BATT} < V_{OUT}$ (Figure 2a)	Up to 11V	LBO = N/\bar{E} LBI- = V_{OUT} LBI+ = V_{IN}
3	High efficiency, 11V, $V_{BATT} < 6.5V$ (Figure 2b)	Up to 11V	LBO = N/\bar{E} LBI- = REF LBI+ = R5, R6
4	Low noise	Up to 11V	N/\bar{E} = PS

Configuration 1: High Efficiency, 7V Max V_{IN}
With N/\bar{E} connected to GND, when the IC boosts, the linear regulator operates only as a switch, with minimum forward drop, until $V_{IN} > V_{OUT}$ (where linear regulation begins). This configuration is limited to no more than 7V input, but provides best efficiency for battery-only operation or low-voltage AC adapter usage.

Configuration 2: High Efficiency, $V_{BATT} < V_{OUT}$
In this configuration, N/\bar{E} is driven high by LBO when $V_{IN} > V_{OUT}$ (Figure 2a). When $V_{IN} < V_{OUT}$, the IC boosts, and the linear regulator operates as a switch, with minimum forward drop. When $V_{IN} > V_{OUT}$, the linear regulator operates with V_{FV} forward drop, while V_{PS} increases by V_{FV} so that OUT maintains regulation. V_{FV} is set inside the IC to approximately 0.5V (at 5V V_{OUT}). When V_{IN} is only slightly higher than V_{OUT} , conversion efficiency is poorer than in configuration 1, so configuration 2 is most suitable when the battery voltage is less than V_{OUT} , but the AC adapter output is greater than V_{OUT} .

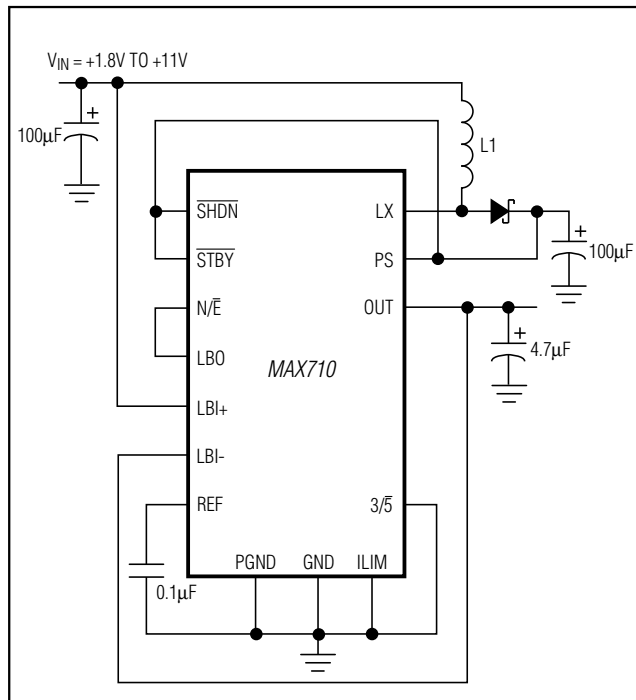

Figure 2a. High-Efficiency Operating Configuration for $V_{BATT} < V_{OUT}$

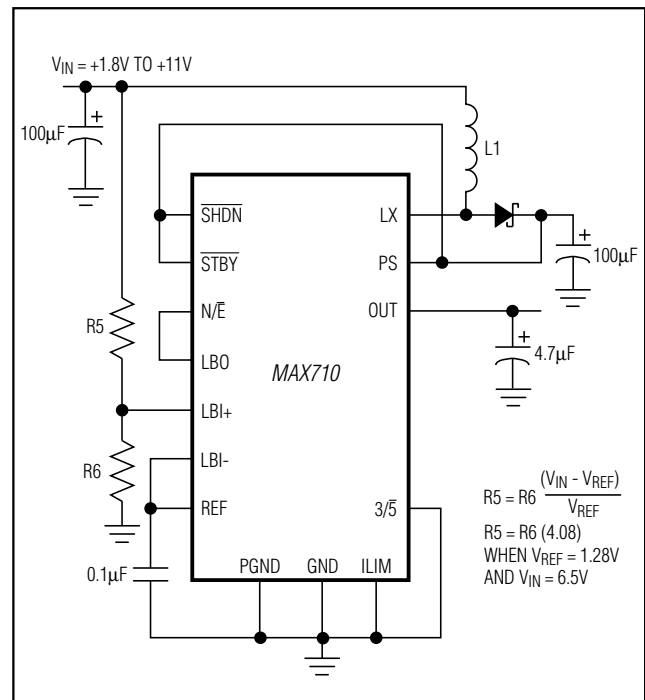

Figure 2b. High-Efficiency Operating Configuration for $V_{BATT} < 6.5V$

MAX710/MAX711

3.3V/5V or Adjustable, Step-Up/Down DC-DC Converters

Configuration 3: High Efficiency, 11V, $V_{BATT} < 6.5V$

In this configuration, N/\bar{E} is driven high by LBO when $V_{IN} > 6.5V$ (Figure 2b). When $V_{IN} < V_{OUT}$, the IC boosts, and the linear regulator operates as a switch, with minimum forward drop. When $V_{IN} > V_{OUT}$, linear regulation begins. When $V_{IN} > 6.5V$ (set by R5 and R6), the linear regulator forces a minimum forward drop of V_{FV} (typically 0.5V at 5V V_{OUT}) as LBO drives N/\bar{E} high. This transition is not seen at the output, since the linear regulator already has an input-output voltage difference of 6.5V - 5V. Efficiency with V_{IN} slightly higher than V_{OUT} is equal to that of configuration 1, so configuration 3 is most suitable when the battery voltage may be near V_{OUT} . This hookup has no functional shortcomings compared with configuration 2, except that two additional resistors (R5 and R6) are needed.

Configuration 4: Low Noise

With N/\bar{E} connected to PS, when the IC is boosting, the linear regulator operates with V_{FV} forward voltage (typically 0.5V at 5V V_{OUT}) for optimum noise rejection. Linear regulation occurs when $V_{IN} > V_{OUT} + V_{FV}$. The V_{FV} voltage differential results in boost efficiency typically 10% lower than with the high-efficiency configurations.

ILIM

The current-limit-select input, ILIM, selects between the two peak current limits: 1.5A (ILIM = GND) and 0.8A (ILIM = PS). If the application requires 200mA or less from the MAX710/MAX711, select 0.8A. The lower peak current limit permits the use of smaller, low-cost inductors. The ILIM input is internally diode clamped to GND and PS, and should not be connected to signals outside this range.

Shutdown and Standby Modes

Grounding \overline{SHDN} turns off the MAX710/MAX711 completely, disconnecting the input from the output. Tie \overline{SHDN} to PS for normal operation.

The MAX710/MAX711 have a standby mode that shuts down the step-up converter. The linear regulator remains on with a 7 μ A (typ) LDO quiescent current. Connect \overline{STBY} to ground to enter standby mode; otherwise, connect \overline{STBY} to PS.

Design Procedure

Output Voltage Selection

For the MAX710, you can obtain a 3.3V or 5V output voltage by tying $3/\bar{5}$ to GND or PS. Efficiency is typically 85% over a 2mA to 250mA load range. The device is bootstrapped, with power derived from the step-up voltage output (at PS). Under all load conditions, the

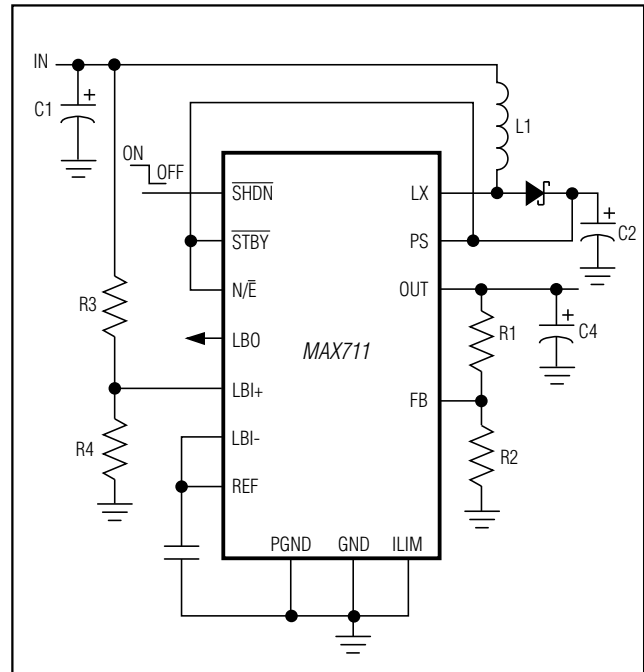

Figure 3. MAX711 Adjustable Output Voltage

MAX710/MAX711 typically start up with a 1V input. If the battery voltage exceeds the programmed output voltage, the output will linear regulate down to the selected output voltage.

The MAX711's adjustable output voltage is set by two resistors, R1 and R2 (Figure 3), which form a voltage divider between the output and FB. Use the following equation to determine the resistor values:

$$R1 = R2 [(V_{OUT} / V_{REF}) - 1]$$

where $V_{REF} = 1.25V$.

Since the input bias current at FB has a maximum value of 50nA, R1 and R2 can be large with no significant accuracy loss. Choose R2 in the 100k Ω to 1M Ω range and calculate R1 using the formula above. For 1% error, the current through R1 should be at least 100 times FB's bias current.

Low-Battery Comparator

The MAX710/MAX711 contain a comparator for low-battery detection. If the voltage at LBI+ falls below that at LBI- (typically connected to REF), LBO goes low. Hysteresis is typically 50mV. Set the low-battery monitor's threshold with two resistors, R3 and R4 (Figure 2), using the following equation:

$$R3 = R4 [(V_{LBT} / V_{LBI-}) - 1]$$

MAX710/MAX711

3.3V/5V or Adjustable, Step-Up/Down DC-DC Converters

Table 2. Component Selection

INDUCTORS (L1)	CAPACITORS	RECTIFIERS (D1)
Sumida CD75-220 (1.5A), CDRH-74-220 (1.23A), or CD54-220	100 μ F, 16V low-ESR tantalum capacitor AVX TPSE107M016R0100 or Sprague 593D107X0016E2W	Schottky diode Motorola MBR5130T3
Coilcraft DO33-08P-223	4.7 μ F, 16V tantalum capacitor Sprague 595D475X0016A2T	

where V_{LBT} is the desired threshold of the low-battery detector and V_{LBI} is the voltage applied to the inverting input of the low-battery comparator. Since LBI current is less than 50nA, R3 and R4 can be large (typically 100k Ω to 1M Ω), minimizing input supply loading. If the low-battery comparator is not used, connect LBI+ to PS and LBI- to REF, leaving LBO unconnected.

Inductor Selection

A 22 μ H inductor value performs well in most MAX710/MAX711 applications. The inductance value is not critical, however, since the MAX710/MAX711 work with inductors in the 18 μ H to 100 μ H range. Smaller inductance values typically offer a smaller size for a given series resistance, allowing the smallest overall circuit dimensions. Circuits using larger inductance values exhibit higher output current capability and larger physical dimensions for a given series resistance. The inductor's incremental saturation current rating should be greater than the peak switch-current limit, which is 1.5A for ILIM = GND and 0.8A for ILIM = PS. However, it is generally acceptable to bias most inductors into saturation by as much as 20%, although this slightly reduces efficiency. The inductor's DC resistance significantly affects efficiency. See Tables 2 and 3 for a list of suggested inductors and suppliers.

Capacitor Selection

A 100 μ F, 16V, 0.1 Ω equivalent series resistance (ESR), surface-mount tantalum (SMT) output filter capacitor, C2, typically exhibits 50mV output ripple when stepping up from 2V to 5V at 100mA. Smaller capacitors (down to 10 μ F with higher ESRs) are acceptable for light loads or in applications that can tolerate higher output ripple. The ESR of both bypass and filter capacitors affects efficiency and output ripple. Output voltage ripple is the product of the peak inductor current and the output capacitor's ESR. Use low-ESR capacitors for best performance, or connect two or more filter capacitors in parallel. Low-ESR, SMT capacitors are currently available from Sprague (595D series) and AVX (TPS series). Sanyo OS-CON organic-semiconductor through-hole capacitors also exhibit very low ESR and are especially

useful for operation at cold temperatures. The output capacitor, C3, needs to be only 4.7 μ F to maintain linear regulator stability. See Tables 2 and 3 for a list of suggested capacitors and suppliers.

Rectifier Diode

For optimum performance, use a switching Schottky diode. Refer to Tables 2 and 3 for the suggested diode and supplier.

Applications Information

The MAX710/MAX711 high-frequency operation makes PC layout important for minimizing ground bounce and noise. Keep the IC's GND pin and the ground leads of C1 and C2 (Figure 1) less than 0.2in. (5mm) apart. Also keep all connections to the FB and LX pins as short as possible. To maximize output power and efficiency and minimize output ripple voltage, use a ground plane and solder the IC's GND pin directly to the ground plane.

Table 3. Component Suppliers

SUPPLIER	PHONE	FAX
AVX	(803) 946-0690	(803) 626-3123
Coilcraft	(847) 639-6400	(847) 639-1469
Motorola	(602) 303-5454	(602) 994-6430
Sanyo	(619) 661-6835	(619) 661-1055
Sprague	(603) 224-1961	(603) 224-1430
Sumida	(847) 956-0666	(847) 956-0702

Chip Information

TRANSISTOR COUNT: 661

SUBSTRATE CONNECTED TO GND

MAX710/MAX711

3.3V/5V or Adjustable, Step-Up/Down DC-DC Converters

Package Information

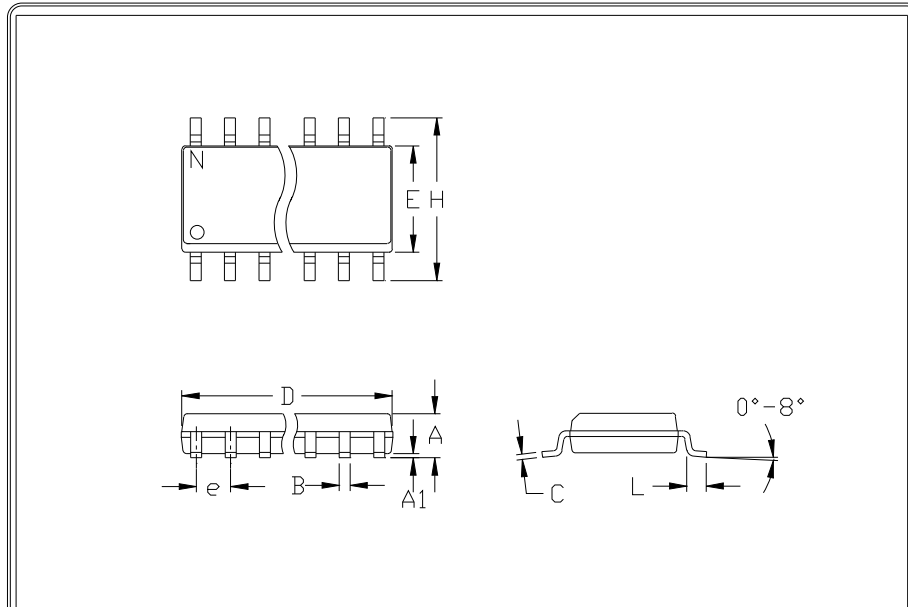

	INCHES		MILLIMETERS	
	MIN	MAX	MIN	MAX
A	0.053	0.069	1.35	1.75
A1	0.004	0.010	0.10	0.25
B	0.014	0.019	0.35	0.49
C	0.007	0.010	0.19	0.25
e	0.050		1.27	
E	0.150	0.157	3.80	4.00
H	0.228	0.244	5.80	6.20
h	0.010	0.020	0.25	0.50
L	0.016	0.050	0.40	1.27

	INCHES		MILLIMETERS		N	MS012
	MIN	MAX	MIN	MAX		
D	0.189	0.197	4.80	5.00	8	A
D	0.337	0.344	8.55	8.75	14	B
D	0.386	0.394	9.80	10.00	16	C

NOTES:

1. D&E DO NOT INCLUDE MOLD FLASH
2. MOLD FLASH OR PROTRUSIONS NOT TO EXCEED .15mm (.006")
3. LEADS TO BE COPLANAR WITHIN .102mm (.004")
4. CONTROLLING DIMENSION: MILLIMETER
5. MEETS JEDEC MS012-XX AS SHOWN IN ABOVE TABLE
6. N = NUMBER OF PINS

PREPRIETARY INFORMATION

PACKAGE FAMILY OUTLINE: SOIC .150"

1/1

21-0041 A

DOCUMENT CONTROL NUMBER REV

MAX710/MAX711

3.3V/5V or Adjustable, Step-Up/Down DC-DC Converters

NOTES



Maxim cannot assume responsibility for use of any circuitry other than circuitry entirely embodied in a Maxim product. No circuit patent licenses are implied. Maxim reserves the right to change the circuitry and specifications without notice at any time. The parametric values (min and max limits) shown in the Electrical Characteristics table are guaranteed. Other parametric values quoted in this data sheet are provided for guidance.